



## Archived Volume

**Title:** ICT in Education, Research, and Industrial Applications. Proc. 15<sup>th</sup> Int. Conf. ICTERI 2019. Volume II: Workshops.

**Editor(s):**

Vadim Ermolayev   
Zaporizhzhia National University, Ukraine  
Frédéric Mallet   
Université Cote d'Azur; CNRS, Inria, I3S, France  
Vitaliy Yakovyna   
University of Warmia and Mazury  
in Olsztyn, Poland; Lviv Polytechnic National University, Ukraine  
Vyacheslav Kharchenko   
National Aerospace University "KhAI", Ukraine  
Vitaliy Kobets   
Kherson State University, Ukraine

Artur Kornilowicz   
University of Bialystok, Poland  
Hennadiy Kravtsov   
Kherson State University, Ukraine  
Mykola Nikitchenko   
Taras Shevchenko National University  
of Kyiv, Ukraine  
Serhiy Semerikov   
Kryvyi Rih State Pedagogical University,  
Ukraine  
Aleksander Spivakovsky   
Kherson State University, Ukraine;  
Verkhovna Rada of Ukraine

**Provided by:** Vadim Ermolayev (on behalf of volume editors)

**Group:** Intelligent Systems, Dept. of Computer Science

**Project:** ICTERI

**Published as:** Ermolayev, V., Mallet, F., Yakovyna, V., Kharchenko, V., Kobets, V., Kornilowicz, A., Kravtsov, H., Semerikov, S., and Spivakovsky, A. (Eds.): ICT in Education, Research, and Industrial Applications. Proc. 15<sup>th</sup> Int. Conf. ICTERI 2019. Volume II: Workshops. Kherson, Ukraine, June 12-15, 2019, CEUR-WS.org, online (<http://ceur-ws.org/Vol-2393/>)

**Publisher:** CEUR Workshop Proceedings (<http://ceur-ws.org/>)

**Abstract:** This volume represents the proceedings of the Workshops co-located with the 15th International Conference on ICT in Education, Research, and Industrial Applications, held in Kherson, Ukraine, in June 2019. It comprises 82 contributed papers that were carefully peer-reviewed and selected from 218 submissions for the five workshops: 3L-Person, CoSinE, ITER, RMSE, and TheRMIT. The volume is structured in five parts, each presenting the contributions for a particular workshop. The topical scope of the volume is aligned with the thematic tracks of ICTERI 2019: (I) Advances in ICT Research; (II) Information Systems: Technology and Applications; (III) ICT in Education; and (IV) ICT Cooperation in Academia and Industry.

**Keywords:** ICT, Advances in ICT Research, ICT Research Infrastructure, Information System, Technology, ICT Application, ICT n Education, ICT-Enabled Cooperation

**License:** CC-BY 4.0 (<https://creativecommons.org/licenses/by/4.0/>)

**DOI:** N/A

Department of Computer Science, Zaporizhzhia National University  
Zhukovs'kogo st. 66 69600 Zaporizhzhia Ukraine

Vadim Ermolayev  
Frédéric Mallet  
Vitaliy Yakovyna  
Vyacheslav Kharchenko  
Vitaliy Kobets  
Artur Kornilowicz  
Hennadiy Kravtsov  
Mykola Nikitchenko  
Serhiy Semerikov  
Aleksander Spivakovsky  
(Eds.)



# **ICT in Education, Research and Industrial Applications**


Proceedings of the 15th International Conference,  
ICTERI 2019. Volume II: Workshops


Kherson, Ukraine  
June, 2019

## Editors


Vadim Ermolayev   
Zaporizhzhia National University, Ukraine


Frédéric Mallet   
Université Cote d'Azur; CNRS, Inria, I3S,  
France

Vitaliy Yakovyna   
University of Warmia and Mazury  
in Olsztyn, Poland; Lviv Polytechnic National  
University, Ukraine

Vyacheslav Kharchenko   
National Aerospace University “KhAI”,  
Ukraine


Vitaliy Kobets   
Kherson State University, Ukraine

Artur Korniłowicz   
University of Białystok, Poland

Hennadiy Kravtsov   
Kherson State University, Ukraine

Mykola Nikitchenko   
Taras Shevchenko National University of  
Kyiv, Ukraine

Serhiy Semerikov   
Kryvyi Rih State Pedagogical University,  
Ukraine

Aleksander Spivakovsky   
Kherson State University, Ukraine;  
Verkhovna Rada of Ukraine

Ermolayev, V., Mallet, F., Yakovyna, V., Kharchenko, V., Kobets, V., Korniłowicz, A., Kravtsov, H., Semerikov, S., and Spivakovsky, A. (Eds.): *ICT in Education, Research, and Industrial Applications. Proc. 15<sup>th</sup> Int. Conf. ICTERI 2019. Volume II: Workshops*. Kherson, Ukraine, June 12-15, 2019, CEUR-WS.org, online

This volume represents the proceedings of the Workshops co-located with the 15th International Conference on ICT in Education, Research, and Industrial Applications, held in Kherson, Ukraine, in June 2019. It comprises 82 contributed papers that were carefully peer-reviewed and selected from 218 submissions for the five workshops: 3L-Person, CoSinE, ITER, RMSE, and TheRMIT. The volume is structured in five parts, each presenting the contributions for a particular workshop. The topical scope of the volume is aligned with the thematic tracks of ICTERI 2019: (I) Advances in ICT Research; (II) Information Systems: Technology and Applications; (III) ICT in Education; and (IV) ICT Cooperation in Academia and Industry.

Copyright © 2019 for the individual papers by the papers' authors.  
Copying permitted only for private and academic purposes. This volume is published and copyrighted by its editors.

## Preface

It is our pleasure to present you the proceedings of the Workshops co-located with ICTERI 2019, the fifteenth edition of the International Conference on Information and Communication Technologies in Education, Research, and Industrial Applications, held in Kherson (Ukraine) on June 12-15, 2019. This year's edition focused on research advances, information systems technologies and applications, business/academic applications of Information and Communication Technologies. Emphasis was also placed on the role of ICT in Education. These aspects of ICT research, development, technology transfer, and use in real world cases remain vibrant for both the academic and industrial communities. Overall, ICTERI 2019, including the Workshops, was focused on the four thematic tracks reflecting these research fields: (I) Advances in ICT Research; (II) Information Systems: Technology and Applications; (III) ICT in Education; and (IV) ICT Cooperation in Academia and Industry.

This volume is structured in five parts, each presenting the contributions to a particular workshop:

Part I: 4<sup>th</sup> International Workshop on Professional Retraining and Life-Long Learning, using ICT: Person-oriented Approach (3L-Person 2019). This workshop was organized by Hennadiy Kravtsov, Svitlana Lytvynova, and Mariya Shyshkina and dedicated to the 20<sup>th</sup> anniversary of the Institute of Information Technologies and Learning Tools of the NAES of Ukraine. The workshop discussed novel research issues and uses of information technology for life-long learning.

Part II: 7<sup>th</sup> International Workshop on on Computer Simulation in Education: A Workshop in Memory of Professor Illia O. Teplytsky (CoSinE 2019). This workshop was organized by Arnold Kiv, Serhiy Semerikov, Vladimir Soloviev, and Andrii Striuk. It addressed real-world applications of computer simulation in education.

Part III: 7<sup>th</sup> International Workshop on Information Technologies in Economic Research (ITER 2019). This workshop was organized by Vitaliy Kobets, Tetiana Paientko, and Alessio Maria Braccini. It focused on research advances, business/academic applications of information and communication technologies related to solving practical economic problems and also pushing forward economic research.

Part IV: 3<sup>d</sup> International Workshop on Rigorous Methods in Software Engineering (RMSE 2019). This workshop was organized by Artur Kornilowicz, Mykola Nikitchenko, Vladimir Peschanenko, and Grygoriy Zholtkevych. It dealt with the aspects of the use of rigorous methods and techniques, which are used in different fields

of software engineering: specification, verification and optimization of software; software analysis, testing, and re-engineering.

Part V: 5<sup>th</sup> International Workshop on Theory of Reliability and Markov Modelling for Information Technologies (TheRMIT 2018). This workshop was organized by Vyacheslav Kharchenko, Elena Zaitseva, De-Jiu Chen, and Bogdan Volochiy. It addressed modern information technologies, systems, and IT-infrastructures as objects of reliability (dependability, safety, security and resilience) regulation, modelling, assessment and assurance. The workshop focused on the mathematical models, application of software tools for IT reliability analysis and assessment, decision support and decision making in the context of the development of dependable, safe, secure and resilient IT-based systems.

Overall, ICTERI 2019 workshops attracted 218 paper submissions. Out of these submissions, the organizers have accepted 82 high quality and most interesting papers. So, the average acceptance rate was of 38 percent.

This volume would not appear without the support of many people. First of all, we would like to thank all the authors who submitted papers to the workshops of ICTERI 2019 and thus demonstrated their interest in the research problems within their scope. We are very grateful to the members of the Program Committees for providing timely and thorough reviews and, also, for being cooperative in doing additional review work. We would like to thank the local organizers of the conference whose devotion and efficiency made the constellation of ICTERI 2019 workshops a very interesting and effective scientific forum.

June, 2019

Vadim Ermolayev  
Frédéric Mallet  
Vitaliy Yakovyna  
Vyacheslav Kharchenko  
Vitaliy Kobets  
Artur Kornilowicz  
Hennadiy Kravtsov  
Mykola Nikitchenko  
Serhiy Semerikov  
Aleksander Spivakovsky

## Committees

### ICTERI 2019 General Chair

Aleksander Spivakovsky, Verkhovna Rada of Ukraine, Kherson State University, Ukraine

### ICTERI Series Steering Committee

Vadim Ermolayev, Zaporizhzhia National University, Ukraine  
Heinrich C. Mayr, Alpen-Adria-Universät Klagenfurt, Austria  
Mykola Nikitchenko, Taras Shevchenko National University of Kyiv, Ukraine  
Aleksander Spivakovsky, Verkhovna Rada of Ukraine, Kherson State University, Ukraine  
Mikhail Zavileysky, DataArt Solutions Inc.  
Grygoriy Zholtkevych, V.N.Karazin Kharkiv National University, Ukraine

### ICTERI 2019 Program Chairs

Vadim Ermolayev, Zaporizhzhia National University, Ukraine  
Frédéric Mallet, Université Cote d'Azur, CNRS, Inria, I3S, France

### ICTERI 2019 Proceedings Chair

Vitaliy Yakovyna, Lviv Polytechnic National University, Ukraine; University of Warmia and Mazury in Olsztyn, Poland

### ICTERI 2019 Publicity Chair

Nataliya Kushnir, Kherson State University, Ukraine

### ICTERI 2019 Web Chair

Alexander Vasileyko, Zaporizhzhia National University, Ukraine

### ICTERI 2019 Local Organization Committee

Maksym Vinnyk (chair), Kherson State University, Ukraine  
Olha Hniedkova, Kherson State University, Ukraine  
Vitalii Kobets, Kherson State University, Ukraine  
Volodymyr Peschanenko, Kherson State University, Ukraine  
Yuliia Tarasich, Kherson State University, Ukraine  
Olha Shmilo, Kherson State University, Ukraine  
Kateryna Panova, Kherson State University, Ukraine  
Nataliya Kushnir, Kherson State University, Ukraine  
Oleksandr Lemeshchuk, Kherson State University, Ukraine  
Daria Malysheva, Kherson State University, Ukraine  
Yaroslava Samchynska, Kherson State University, Ukraine

### **3L-Person 2019 Workshop Program Chairs**

**Hennadiy Kravtsov**, Kherson State University, Ukraine  
**Svitlana Lytvynova**, Institute of Information Technologies and Learning Tools, NAES of Ukraine  
**Mariya Shyshkina**, Institute of Information Technologies and Learning Tools, NAES of Ukraine

### **CoSinE 2019 Workshop Program Chairs**

**Arnold Kiv**, Ben-Gurion University of the Negev, Israel  
**Serhiy Semerikov**, Kryvyi Rih State Pedagogical University, Ukraine  
**Vladimir Soloviev**, Kryvyi Rih State Pedagogical University, Ukraine  
**Andrii Striuk**, Kryvyi Rih National University, Ukraine

### **ITER 2019 Workshop Program Chairs**

**Vitaliy Kobets**, Kherson State University, Ukraine  
**Tetiana Paientko**, Kyiv National Economic University named after Vadym Hetman, Ukraine  
**Alessio Maria Braccini**, Università degli Studi della Toscana, Italy

### **RMSE 2019 Workshop Program Chairs**

**Artur Kornilowicz**, University of Bialystok, Poland  
**Mykola Nikitchenko**, Taras Shevchenko National University of Kyiv, Ukraine  
**Vladimir Peschanenko**, Kherson State University, Ukraine  
**Grygoriy Zholtkevych**, V.N. Karazin Kharkiv National University, Ukraine

### **TheRMIT 2019 Workshop Program Chairs**

**Vyacheslav Kharchenko**, National Aerospace University “KhAI”, Ukraine  
**De-Jiu Chen**, KTH University, Sweden  
**Elena Zaitseva**, Žilina University, Slovakia  
**Bogdan Volochiy**, Lviv Polytechnic National University, Ukraine

### **Program Committees**

#### **3L-Person 2019 Workshop**

**Oleksandr Burov**, Institute of Information Technologies and Learning Tools, NAES of Ukraine  
**Valeriy Bykov**, Institute of Information Technologies and Learning Tools, NAES of Ukraine  
**Helena Fidlerova**, Institute of Industrial Engineering and Management, Slovak Republic  
**Olena Glazunova**, National University of Life and Environmental Sciences of Ukraine  
**Olga Hniedkova**, Kherson State University, Ukraine  
**Ulyana Kogut**, Drohobych Ivan Franko State Pedagogical University, Ukraine  
**Oleksandr Kolgatin**, Kharkiv National Pedagogical University named after G.S. Skovoroda, Ukraine  
**Hennadiy Kravtsov**, Kherson State University, Ukraine  
**Vladyslav Kruglyk**, Kherson State University, Ukraine  
**Julia Krylova-Grek**, State University of Information and Communication Technologies, Ukraine  
**Olena Kuzminska**, National University of Life and Environmental Sciences of Ukraine  
**Yevgenij Lavrov**, Sumy State University, Ukraine  
**Svitlana Lytvynova**, Institute of Information Technologies and Learning Tools, NAES of Ukraine  
**Yuliya Nosenko**, Institute of Information Technologies and Learning Tools, NAES of Ukraine

**Anastasiia Novikova**, Fraunhofer Institute for Computer Graphics Research, Rostock, Germany  
**Vasyl Oleksiuk**, Ternopil Volodymyr Hnatiuk National Pedagogical University, Ukraine  
**Nataliia Osipova**, Kherson State University, Ukraine  
**Pawel Plaskura**, Jan Kochanowski University in Kielce, Poland  
**Maiia Popel**, Institute of Information Technologies and Learning Tools, NAES of Ukraine  
**Mykhaylo Sherman**, Kherson State University, Ukraine  
**Mariya Shyshkina**, Institute of Information Technologies and Learning Tools, NAES of Ukraine  
**Ivan Tsidylo**, Ternopil Volodymyr Hnatiuk National Pedagogical University, Ukraine  
**Tetiana Vdovychyn**, Drohobych Ivan Franko State Pedagogical University, Ukraine  
**Alexander Weissblut**, Kherson State University, Ukraine

#### **Additional Reviewers**

**Svitlana Kravets**, Ternopil Volodymyr Hnatiuk National Pedagogical University, Ukraine

#### **CoSinE 2019 Workshop**

**Liudmyla Bilousova**, H. S. Skovoroda Kharkiv National Pedagogical University, Ukraine  
**Emre Erturk**, Eastern Institute of Technology, New Zealand  
**Irina Georgescu**, Academy of Economic Studies, Romania  
**Alytis Gruodis**, Vilnius University, Lithuania  
**Vita Hamanyuk**, Kryvyi Rih State Pedagogical University, Ukraine  
**Nadia Kabachi**, Claude Bernard Lyon 1 University, France  
**Taras Kavetsky**, John Paul II Catholic University of Lublin, Poland  
**Oleksandr Kolgatin**, H. S. Skovoroda Kharkiv National Pedagogical University, Ukraine  
**Tatyana Koycheva**, K. D. Ushynsky South Ukrainian National Pedagogical University, Ukraine  
**Tamara Lobanova-Shunina**, Riga Technical University, Latvia  
**Alex Merzlykin**, Kryvyi Rih Educational Complex No 129 “Gymnasium-Lyceum of Academic Direction”, Ukraine  
**Yuliya Nosenko**, Institute of Information Technologies and Learning Tools, NAES of Ukraine  
**Sumitra Nuanmeesri**, Suan Sunandha Rajabhat University, Thailand  
**Laima Okuneviciute Neverauskiene**, Vilnius Gediminas Technical University and Lithuanian Social Research Centre, Lithuania  
**Jaderick P. Pabico**, University of the Philippines Los Baños, Philippines  
**Liubov Panchenko**, National Technical University of Ukraine “Igor Sikorsky Kyiv Polytechnic Institute”, Ukraine  
**Giouli Pappa**, Cyprus University of Technology, Cyprus  
**Lukas Pichl**, International Christian University, Japan  
**Olga Pinchuk**, Institute of Information Technologies and Learning Tools, NAES of Ukraine  
**Nina Rizun**, Gdańsk University of Technology, Poland  
**Eugene Sedov**, K. D. Ushynsky South Ukrainian National Pedagogical University, Ukraine  
**Oleksandra Sokolyuk**, Institute of Information Technologies and Learning Tools, NAES of Ukraine  
**Nataliia P. Volkova**, Alfred Nobel University, Ukraine  
**Yuliia Yechkalo**, Kryvyi Rih National University, Ukraine

#### **Additional Reviewers**

**Pavlo Nechypurenko**, Kryvyi Rih State Pedagogical University, Ukraine  
**Iryna Topolova**, Kryvyi Rih Educational Complex No 129 “Gymnasium-Lyceum of Academic Direction”, Ukraine

#### **ITER 2019 Workshop**

**Lloyd P. Blenman**, University of North Carolina-Charlotte, USA  
**Alessio Maria Braccini**, Università degli Studi della Toscana, Italy  
**Anna Burduk**, Wrocław University of Science and Technology, Poland  
**Tom Coupé**, University of Canterbury, New Zealand  
**Lina Dagilienė**, Kaunas University of Technology, Lithuania  
**Justyna Dobroszek**, University of Lodz, Poland



**G. Scott Erickson**, Ithaca College, USA  
**Tommaso Federici**, Università degli Studi della Tuscia, Italy  
**Javier F. Garcia**, Humboldt International University, USA  
**Bartłomiej Gładysz**, Politechnika Warszawska, Poland  
**Arkadiusz Gola**, Lublin University of Technology, Poland  
**Jakub Krzysztof Grabski**, Poznan University of Technology, Poland  
**Magdalena Graczyk-Kucharska**, Poznan University of Technology, Poland  
**Lidiia Hladchenko**, Kyiv National Economic University named after Vadym Hetman, Ukraine  
**Alexander Hošovský**, Technical University of Kosice, Slovakia  
**John S. Johnson**, Humboldt International University, USA  
**Kestutis Kapocius**, Kaunas University of Technology, Lithuania  
**Ganna Kharlamova**, Taras Shevchenko National University of Kyiv, Ukraine  
**Jurij Klapkiv**, University of Lodz, Poland  
**Dmytro Klets**, Kharkiv National Automobile and highway University, Ukraine  
**Vitaliy Kobets**, Kherson State University, Ukraine  
**Forcim Kola**, “Marin Barleti” University, Albania  
**Kamil Krot**, Wrocław University of Science and Technology, Poland  
**Sergey Kryukov**, Southern Federal University, Russian Federation  
**Vira Liubchenko**, Odessa National Polytechnic University, Ukraine  
**Serhii Makarenko**, Kherson State University, Ukraine  
**Zoriana Matsuk**, Ivano-Frankivsk national technical university of oil and gas, Ukraine  
**Ibish Mazreku**, University “Haxhi Zeka”, Kosovo  
**Jan-Hendrik Meier**, Kiel University of Applied Sciences, Germany  
**Ihor Oleksiv**, Lviv Polytechnic National University, Ukraine  
**Nataliya Osipova**, Kherson State University, Ukraine  
**Tetiana Paientko**, Kyiv National Economic University named after Vadym Hetman, Ukraine  
**Liubov Pankratova**, National University of Life and Environmental Sciences of Ukraine, Ukraine  
**Alla Polyanska**, Ivano-Frankivsk National Technical University of Oil and Gas, Ukraine  
**Boris Popesko**, Tomas Bata University in Zlín, Czech Republic  
**Kateryna Proskura**, University of the State Fiscal Service of Ukraine, Ukraine  
**Robert Rickards**, German Police University, Germany  
**Maria Rosienkiewicz**, Wrocław University of Science and Technology, Poland  
**Jean-François Rougé**, Sofia University of Technology, Bulgaria  
**Mohsin R. Shaikh**, University of Pune, India  
**Alfreda Šapkauskienė**, Kaunas University of Technology, Lithuania  
**Victor Selyutin**, Southern Federal University, Russian Federation  
**Serhiy Semerikov**, Kryvyi Rih State Pedagogical University, Ukraine  
**Oleksandr Snihovyi**, DataArt, Ukraine  
**Grigor Stambolov**, Technical University of Sofia, Bulgaria  
**Olena Tymchenko**, Kyiv National Economic University named after Vadym Hetman, Ukraine  
**Borut Werber**, University of Maribor, Slovenija  
**Viktoria Yatsenko**, Kherson National Technical University, Ukraine  
**Jusuf Zeqiri**, South East European University, Macedonia  
**Rong Zhang**, Nishinippon Institute of Technology, Japan

## RMSE 2019 Workshop

**Sergiy Bogomolov**, Australian National University, Australia  
**Gabriel Ciobanu**, “Alexandru Ioan Cuza” University of Iasi, Romania  
**Anatoliy Doroshenko**, National Technical University of Ukraine Igor Sikorsky Kyiv Polytechnic Institute, Ukraine  
**Pavel Drobintsev**, Saint-Petersburg State Polytechnic University, Russian Federation  
**Ioachim Drugus**, Institute of Mathematics and Computer Science, Moldova  
**Artur Kornilowicz**, University of Bialystok, Poland  
**Vsevolod Kotlyarov**, Saint-Petersburg State Polytechnic University, Russian Federation  
**Mykola Nikitchenko**, Taras Shevchenko National University of Kyiv, Ukraine  
**Oleksandr Letychevskiy**, Glushkov Institute of Cybernetics, National Academy of Sciences of Ukraine  
**Michael Lvov**, Kherson State University, Ukraine

**Alexander Lyaletski**, Institute of Mathematics and Computer Science, Moldova  
**Vladimir Peschanenko**, Kherson State University, Ukraine  
**Wolfgang Schreiner**, Research Institute for Symbolic Computation of Johannes Kepler University Linz  
Austria  
**Stepan Shkilniak**, Taras Shevchenko National University of Kyiv, Ukraine  
**Volodymyr Skobelev**, Glushkov Institute of Cybernetics, National Academy of Sciences of Ukraine  
**Grygoriy Zholtkevych**, V.N. Karazin Kharkiv National University, Ukraine

#### **Additional Reviewers**

**Kostyantyn Potomkin**, Australian National University, Australia

#### **TheRMIT 2019 Workshop**

**Nikos Bardis**, University of Athens, Greece  
**Nikolaos Doukas**, Hellenic Army Academy, Greece  
**Anatoliy Gorbenko**, Leeds Beckett University, United Kingdom  
**Herman Fesenko**, National Aerospace University “KhAI”, Ukraine  
**Mario Fusani**, Institute of Information Science and Technologies, CNR, Italy  
**Anton Kamenskih**, Perm Research Technical University, Russia  
**Yuriy Kondratenko**, Petro Mohyla Black Sea National University, Ukraine  
**Ah-Lian Kor**, Leeds Beckett University, United Kingdom  
**Oleksandr Letychevskiy**, Glushkov Institute of Cybernetics, National Academy of Sciences of Ukraine  
**Vitaly Levashenko**, Žilina University, Slovakia  
**Sergii Lysenko**, Khmelnytsky National University, Ukraine  
**Dmitry Maevsky**, Odessa National Polytechnic University, Ukraine  
**Olexandr Gordieiev**, University of Banking, National Bank of Ukraine  
**Oleg Odarushchenko**, Research and Production Company Radiy, Ukraine  
**Yurij Ponochovnyj**, Poltava National Technical National University, Ukraine  
**Andrzej Rucinski**, New Hampshire University, USA  
**Vladimir Sklyar**, Research and Production Company Radiy, Ukraine  
**Larisa Titarenko**, University of Zelena Gura, Poland  
**Jüri Vain**, Tallinn University of Technology, Estonia

#### **Additional Reviewers**

**Luigi Buglione**, Institute of Information Science and Technologies, CNR, Italy  
**Andriy Mashchak**, Lviv Polytechnic National University, Ukraine  
**Leonig Ozirkovskyy**, Lviv Polytechnic National University, Ukraine  
**Mykhailo Zmysnyi**, Lviv Polytechnic National University, Ukraine  
**Oleksandr Shkiliuk**, Lviv Polytechnic National University, Ukraine  
**Aleksei Vambol**, National Aerospace University “KhAI”, Ukraine

## Sponsors



**Kherson State University (KSU)**, <http://www.ksu.ks.ua/>) is a versatile scientific, educational, and cultural center in the South of Ukraine. It offers full-day, extra-mural, external study programs attended by 8,000 students from 23 regions of Ukraine and CIS countries. Its research and teaching staff comprises 18 members of the Ukrainian and foreign Academies of Science, 68 professors, 234 senior lecturers. About 1,000 students are enrolled to its advanced degree programs at Ph.D and Dr.Sci levels.



**Oleksandr Spivakovsky's Educational Foundation (OSEF)**, <http://spivakovsky.fund/>) aims to support gifted young people, outstanding educators, and also those who wish to start up their own business. OSEF activity is focused on the support and further development of educational, scientific, cultural, social and intellectual spheres in the Kherson Region of Ukraine.



**DataArt** (<http://dataart.com/>) develops industry-defining applications, helping clients optimize time-to-market and minimize software development risks in mission-critical systems. Domain knowledge, offshore cost advantages, and efficiency – that's what makes DataArt a partner of choice for their global clients.



**BWT Group** (<http://www.groupbwt.com/>) are those who do coding all day and night long. For you. We can do anything, that's it. The work we do, and how we do it, is defined in large part by the culture we've developed. We seek to build an organization that each and every one of us enjoys being a part of, where people feel valued, inspired to grow, and are willing to do what's necessary to take care of each other and our client.

## Organizers



Ministry of Education and Science of Ukraine  
<http://www.mon.gov.ua/>



Kherson State University, Ukraine  
<http://www.kspu.edu/>



Université Côte d'Azur, France  
<http://univ-cotedazur.fr/en>



Zaporizhzhia National University, Ukraine  
<http://www.znu.edu.ua/en/>



Lviv Polytechnic National University, Ukraine  
<http://www.lp.edu.ua/en>



Institute of Information Technology and Teaching Resources, NAPIS,  
Ukraine  
<http://iitlt.gov.ua/eng/index.php>



Ben-Gurion University of the Negev, Israel  
<http://in.bgu.ac.il/en/pages/default.aspx>



Kryvyi Rih State Pedagogical University, Ukraine  
<https://kdpu.edu.ua/en/>



Kyiv National Economic University named after Vadym  
Hetman, Ukraine  
<https://kneu.edu.ua/en/>



Università degli Studi della Tuscia, Italy  
<http://www.unitus.it/>



University of Białystok, Poland  
<http://www.uwb.edu.pl/>



Taras Shevchenko National University of Kyiv, Ukraine  
<http://www.univ.kiev.ua/en/>



V.N. Karazin Kharkiv National University, Ukraine  
<http://www.univer.kharkov.ua/en>



National Aerospace University "KhAI", Ukraine  
<http://www.khaiedu.com/>



KTH Royal Institute of Technology, Sweden  
<https://www.kth.se/en>



University of Žilina, Slovakia  
<https://www.uniza.sk/index.php/en/>

## Table of Contents

### Part I: 4th International Workshop on Professional Retraining and Life-Long Learning using ICT: Person-oriented Approach (3L-Person 2019)

About One Approach to Building Systems for Testing Physical Knowledge . . .	1
<i>Michail Lvov, Sergiy Kuzmenkov and Hennadiy Kravtsov</i>	
Increase of the Level of Graphic Competence Future Bachelor in Computer Sciences in the Process of Studying Three-Dimensional Modeling . . . . .	17
<i>Hanna Chemerys, Kateryna Osadcha, Viacheslav Osadchy and Vladyslav Kruhlyk</i>	
Ontological Model of Representation of University Resources . . . . .	29
<i>Bogdan Buyak, Ivan Tsidylo, Serhiy Kozibroda and Victor Repskyi</i>	
Mathematical Models and Methods of Supporting the Solution of the Geometry Tasks In Systems of Computer Mathematics for Educational Purposes. . . . .	41
<i>Irina Chernenko, Michael Lvov, Ludmila Shishko and Evgen Kozlovsky</i>	
Attitude to the Digital Learning Environment in Ukrainian Universities . . . . .	53
<i>Olena Kuzminska, Mariia Mazorchuk, Nataliia Morze and Oleg Kobylin</i>	
The Blended Methodology of Learning Computer Networks: Cloud-based Approach. . . . .	68
<i>Oleg Spirin, Vasyl Oleksiuk, Nadiia Balyk, Svitlana Lytvynova and Sergiy Sydorenko</i>	
The Method of Using the Maxima System for Operations Research Learning . . . . .	81
<i>Mariya Shyshkina and Uliana Kohut</i>	
The Comparative Analysis of the Cloud-based Learning Components Delivering Access to Mathematical Software . . . . .	93
<i>Mariya shyshkina, Uliana Kohut and Maiia Popel</i>	
Electronic Textbook as a Component of Smart Kids Technology of Education of Elementary School Pupils . . . . .	105
<i>Svitlana Lytvynova</i>	

Technologies of Virtual and Augmented Reality for High Education and Secondary School . . . . .	121
<i>Nataliia Osipova, Hennadiy Kravtsov, Olga Gnedkova, Tetiana Lishchuk and Kateryna Davidenko</i>	
Activity Plan Template for Supporting Study Science with Robotics and Programming . . . . .	132
<i>Tatiana Goncharenko, Nataliya Kushnir, Nataliia Valko and Nataliya Osipova</i>	
Determining the Level of Readiness of Teachers to Implementation of STEM-Education in Ukraine . . . . .	144
<i>Viacheslav Osadchyi, Nataliia Valko and Natalya Kushnir</i>	
Open Distance Learning For Teachers . . . . .	156
<i>Vladimir Kukhareenko and Tatyana Oleinik</i>	
The Technique to Evaluate Pupils' Intellectual and Personal Important Qualities for ICT Competences . . . . .	170
<i>Oleksandr Burov, Svitlana Lytvynova and Olga Slobodyanyk</i>	
The Method for Forming the Health-Saving Component of Basic School Students' Digital Competence . . . . .	178
<i>Yuliya Nosenko and Alisa Sukhikh</i>	
ICT in Professional Education of Future Primary School Teachers: Modeling of Scientific and Research Work . . . . .	191
<i>Yevheniia Spivakovska, Tetyana Vinnyk, Liudmilla Perminova and Vera Kotkova</i>	
Design of Approaches to the Development of Teacher's Digital Competencies in the Process of Their Lifelong Learning . . . . .	204
<i>Nadiia Balyk, Yaroslav Vasylenko, Galina Shmyger, Vasyl Oleksiuk and Anna Skaskiv</i>	
Information System of Scientific Activity Indicators of Scientific Organizations: Development Status and Prospects . . . . .	220
<i>Aleksander Spivakovsky, Maxym Vinnyk, Maksym Poltorackiy, Yevheniia Spivakovska, Yuliia Tarasich, Greg Gardner and Kateryna Panova</i>	
Advanced Information Technology Tools for Media and Information Literacy Training . . . . .	229
<i>Yuliya Krylova-Grek</i>	

**Part II: 7th International Workshop on Information Technologies  
in Economic Research (ITER 2019)**

Information-analytical Support for the Processes of Formation of "Smart Sociopolis" of Truskavets . . . . .	241
<i>Mykola Odrekhivskyy, Nataliia Kunanets, Volodymyr Pasichnyk, Antonii Rzhenskyi and Danylo Tabachyshyn</i>	
The Main Aspects of the Introduction of ERP-Systems at the Machine-Building Enterprises . . . . .	257
<i>Irina Nyzhnyk and Viktor Lysak</i>	
Business Models of Reproduction Cycles for Digital Economy . . . . .	269
<i>Leonid Melnyk, Oleksandr Derykolenko, Oleksandr Kubatko and Oleksandr Matsenko</i>	
Support of Investors' Decision Making in Economic Experiments using Software Tools . . . . .	277
<i>Daria Kilinich and Vitaliy Kobets</i>	
Application of Geographic Information Systems in the Field of Domestic Waste Management . . . . .	289
<i>Olga Popova, Liubov Pankratova and Inesa Mikhno</i>	
Forecasting of Cereal Crop Harvest on the Basis of an Extrapolation Canonical Model of a Vector Random Sequence . . . . .	302
<i>Igor Atamanyuk, Yuriy Kondratenko, Anastasiya Poltorak, Natalia Sirenko, Vyacheslav Shebanin, Inna Baryshevska and Valeriia Atamaniuk</i>	
Cloud Based Architecture of the Core Banking System . . . . .	316
<i>Andrii Roskladka, Nataliia Roskladka, Ganna Kharlamova and Roman Baglai</i>	
Forecasting Prices on the Stock Exchange Using a Trading System . . . . .	332
<i>Liubov Pankratova, Tetiana Paientko and Yaroslav Lysenko</i>	
The Relationship between Oil and Gas Prices, Dow Jones and US Dollar Indexes: A Wavelet Co-movement Estimation and Neural Network Forecasting. . . . .	348
<i>Olena Liashenko and Tetyana Kravets</i>	
Short-term Electricity Price Forecasting Using Generalized Additive Models . . . . .	364
<i>Jan-Hendrik Meier, Stephan Schneider and Chan Le</i>	



Budgeting Integration with a Business Strategy and Accounting System in Business Process Management - Case Study of Ukrainian Company . . . . .	379
<i>Viktoria Yatsenko and Yevhen Kudriavets</i>	
Can Information Technology Increase Government Effectiveness? . . . . .	393
<i>Tetiana Paientko and Viktor Fedosov</i>	
Cluster Analysis of Countries Inequality due to IT Development . . . . .	406
<i>Vitaliy Kobets, Valeria Yatsenko and Mykhaylo Voynarenko</i>	
Simplified Model of Bank Balance Sheet Management . . . . .	422
<i>Victor Selyutin</i>	
Entropy Analysis of Crisis Phenomena for DJIA Index. . . . .	434
<i>Vladimir Soloviev, Andrii Bielinskyi and Viktoria Solovieva</i>	
Influence of the Country's Information Development on its Tourist Attractiveness . . . . .	450
<i>Yuliia Lola, Svitlana Prokopovych and Olena Akhmedova</i>	
Empowering Fault-Tolerant Consensus Algorithm by Economic Leverages . .	465
<i>Igor Mazurok, Valeriy Pienko and Yevhen Leonchik</i>	
Government Financial Support of Higher Education and its Role in Economic Prosperity of a Society . . . . .	473
<i>Marina Bilinets, Lidiia Hladchenko and Tetiana Paientko</i>	
Simulation of the Crisis Contagion Process Between Countries with Different Levels of Socio-Economic Development . . . . .	485
<i>Andriy Matviychuk, Inna Strelchenko, Serhii Vashchaiev and Halyna Velykoivanenko</i>	
<b>Part III: 3rd International Workshop on Rigorous Methods in Software Engineering (RMSE 2019)</b>	
Computations in Extensions of Multisorted Algebras . . . . .	497
<i>Michael Lvov</i>	
On Some Classes of Problems on Graphs . . . . .	513
<i>Volodymyr G. Skobelev</i>	
Extending the SMT-Lib Standard with Theory of Nominative Data . . . . .	522
<i>Liudmyla Omelchuk and Olena Shyshatska</i>	
Data Compression and Representation as Multicolor Barcodes . . . . .	534
<i>Ivan Dychka and Olga Sulema</i>	
On the Kleene Algebra of Partial Predicates with Predicate Complement . . . .	542
<i>Ievgen Ivanov and Mykola Nikitchenko</i>	

Computational Modeling and Structural Stability . . . . .	552
<i>Alexander Weissblut</i>	
Event Universes: Specification and Analysis Using Coq Proof Assistant . . . .	568
<i>Grygoriy Zholtkevych</i>	
Formalization and Algebraic Modeling of Tokenomics Projects . . . . .	577
<i>Oleksandr Letychevskyi, Volodymyr Peschanenko, Viktor Radchenko, Maksym Poltoratskyi and Yuliia Tarasich</i>	
Formalization and Algebraic Modeling of University Economics . . . . .	585
<i>Vladimir Peschanenko, Maksym Poltorackiy and Karina Pryimak</i>	
Formalization of the Model of Management of the Technological Innovations . . . . .	595
<i>Vitalina Babenko</i>	
Program Logics of Renominative Level with the Composition of Predicate Complement. . . . .	603
<i>Mykola Nikitchenko, Oksana Shkilniak and Stepan Shkilniak</i>	
<b>Part IV: 5th International Workshop on Theory of Reliability and Markov Modeling for Information Technologies (TheRMIT 2019)</b>	
Agent-Oriented Information Technology for Assessing the Initial Stages of the Software Life Cycle . . . . .	617
<i>Tetiana Hovorushchenko, Artem Boyarchuk, Olga Pavlova and Kira Bobrovnikova</i>	
Dynamic Signature-based Malware Detection Technique Based on API Call Tracing. . . . .	633
<i>Oleg Savenko, Andrii Nicheporuk, Ivan Hurman and Sergii Lysenko</i>	
On-Line Checking of Faults in Cyber-Physical Systems . . . . .	644
<i>Volodymyr G. Skobelev and Volodymyr V. Skobelev</i>	
Ensuring the Security of the Full Logistics Supply Chain Based on the Blockchain Technology . . . . .	655
<i>Igor Shostak, Yashar Rahimi, Mariia Danova, Olena Feoktystova and Olga Melnyk</i>	
Application of the Booking.com Analytics Software Tools in Reliable Processing of Big Data in Hotels Management . . . . .	664
<i>Vladimir Sklyar and Vyacheslav Kharchenko</i>	

Reliability of Adaptive Traffic Lights Ensured by Warm Standby with Estimation of its Use . . . . .	678
<i>Oleksandr Makarichev, Peter Horbachov, Oleksandr Voronkov and Stanislav Svichynskiy</i>	
Random Re-Ordering of the Parties in the Consensus Protocol . . . . .	694
<i>Andrey Sobol, Volodymyr G. Skobelev, Julian Konchunas, Viktor Radchenko, Sabina Sachtachtinskaga, Oleksandr Letychevskiy, Volodymyr Peschanenko, Maxim Orlovsky</i>	
Optimization of Flows and Flexible Redistribution of Autonomous UAV Routes in Multilevel Airspace. . . . .	704
<i>Tetiana Shmelova, Arnold Sterenharz and Oleksand Burlaka</i>	
Intelligent Method for CSIRT Performance Evaluation in Critical Information Infrastructure . . . . .	716
<i>Viktor Gnatyuk, Serhii Smirnov, Marek Aleksander, Liudmila Kharlai, Madina Bauyrzhan, Anzhelika Kokareva</i>	
Polynomials Multiplier under Irreducible Polynomial Module for High-Performance Cryptographic Hardware Tools . . . . .	729
<i>Maksat Kalimoldayev, Sahibay Tynymbayev, Miras Magzom, Margulan Ibraimov, Serik Khokhlov, Akmaral Abisheva, Viktoriia Sydorenko and Sergiy Gnatyuk</i>	
Multi-Fragmental Markov Models of Information and Control Hardware-Software Faults . . . . .	738
<i>Vyacheslav Kharchenko, Yuriy Ponochovnyi, Artem Boyarchuk and Anton Andrashov</i>	
Power-Oriented Checkability of Matrix and Pipeline Circuits in FPGA-Based Digital Components of Safety-Related Systems . . . . .	749
<i>Oleksandr Drozd, Viktor Antoniuk, Miroslav Drozd and Hanna Stepova</i>	
Discrete-Continuous Stochastic Model of Behavior Algorithm of Surveillance and Target Acquisition System . . . . .	762
<i>Oleksandr Shkiliuk, Bohdan Volochiy and Ivan Petliuk</i>	
Methodology of Defining the Accident Rate Function for Fault Tolerant System with High Responsibility Purpose . . . . .	778
<i>Leonid Ozirkovskyy, Bohdan Volochiy, Mykhailo Zmysnyi and Andriy Maschak</i>	
Discrete-Continuous Stochastic Model of Insulin Pump Functioning for Health IoT System Using Erlang Phase Method. . . . .	794
<i>Anastasiia Strielkina, Serhiy Volochiy and Vyacheslav Kharchenko</i>	

High-Speed Privacy Amplification Method for Deterministic Quantum Cryptography Protocols Using Pairs of Entangled Qutrits . . . . .	810
<i>Zhengbing Hu, Sergiy Gnatyuk, Tetyana Okhrimenko (Zhmurko), Vasyl Kinzeryavyy, Maksim Iavich, Khalicha Yubuzova</i>	
Quality Assessment of Unmanned Aerial Systems Using Bayesian Trust Networks Processing of Testing Data . . . . .	822
<i>Ol'ha Bashyns'ka, Volodymyr Kazymyr and Sergii Nesterenko</i>	
<b>Part V: 7th Workshop on Computer Simulation in Education (CoSinE 2019): A Workshop in memory of Professor Illia O. Teplytskyi</b>	
Computer Simulation of Neural Networks Using Spreadsheets: Dr. Anderson, Welcome Back . . . . .	833
<i>Serhiy Semerikov, Illia Teplytskyi, Yuliia Yechkalo, Oksana Markova, Vladimir Soloviev and Arnold Kiv</i>	
Computer Modelling of Educational Process as the Way to Modern Learning Technologies . . . . .	849
<i>Tatyana Zaytseva, Lyudmyla Kravtsova and Anna Puliaieva</i>	
The Simultaneous Use of Excel and GeoGebra to Training the Basics of Mathematical Modeling . . . . .	864
<i>Leonid Flehantov and Yuliia Ovsienko</i>	
Computer Simulation as a Method of Learning Research in Computational Mathematics . . . . .	880
<i>Lyudmyla Bilousova, Oleksandr Kolgatin and Larisa Kolgatina</i>	
Methodology of Using Structural Equation Modeling in Educational Research . . . . .	895
<i>Liubov Panchenko</i>	
Modeling of Cognitive Process Using Complexity Theory Methods . . . . .	905
<i>Vladimir Soloviev, Natalia Moiseenko and Olena Tarasova</i>	
Computation Algorithm for Integral Indicator of Socio-Economic Development . . . . .	919
<i>Oleg Pursky, Tetiana Dubovyk, Iryna Gamova and Iryna Buchatska</i>	

Simulation System in Educational and Career Guidance State Policy of Ukraine . . . . .	935
<i>Vitalii Pazdrii, Petr Banschykov, Victoria Kosyk, Irina Tropina and Oleksandr Hryshchenko</i>	
Using Computer Simulations and Games in Engineering Education: Views from the Field . . . . .	944
<i>Muhammet Demirbilek and Durmuş Koç</i>	
Augmented Reality in Training Engineering Students: Teaching Techniques . .	952
<i>Yuliia Yechkalo, Viktoriia Tkachuk, Tetiana Hrunтова, Dmytro Brovko and Vitaliy Tron</i>	
Designing of Virtual Cloud Labs for the Learning Cisco CyberSecurity Operations Course . . . . .	960
<i>Nadiia Balyk, Yaroslav Vasylenko, Vasyl Oleksiuk and Galina Shmyger</i>	
Using the Cloud-Oriented Virtual Chemical Laboratory VLab in Teaching the Solution of Experimental Problems in Chemistry of 9th Grade Students . . . . .	968
<i>Pavlo Nechypurenko, Tetiana Selivanova and Maryna Chernova</i>	
Adaptive Testing Model as the Method of Quality Knowledge Control Individualizing . . . . .	984
<i>Nonna Shapovalova, Olena Rybalchenko, Iryna Dotsenko, Svitlana Bilashenko, Andrii Striuk and Levan Saitgareev</i>	
Intelligent Adaptation Method for Human-Machine Interaction in Modular E-Learning Systems . . . . .	1000
<i>Evgeniy Lavrov and Olga Lavrova</i>	
Historical Approach to Modern Learning Environment . . . . .	1011
<i>Aleksander Spivakovsky, Lyubov Petukhova, Vira Kotkova and Yuriy Yurchuk</i>	
Author Index . . . . .	1025

# About One Approach to Building Systems for Testing Physical Knowledge

Michail Lvov <sup>[0000-0002-0876-9928]</sup>, Sergey Kuzmenkov <sup>[0000-0002-5257-9523]</sup> and  
Hennadiy Kravtsov <sup>[0000-0003-3680-2286]</sup>

Kherson State University, 27 Universitetska st., Kherson, 73000 Ukraine  
lvov@ksu.ks.ua, ksg@ksu.ks.ua, kgm@ksu.ks.ua

**Abstract.** The paper presents an approach to building a system for testing procedural physical knowledge, i.e. knowledge of basic physical laws and the ability to use them.

This approach consists of constructing mathematical models for each academic module in a physics course. The main constructive objects are test templates, which are mathematical models of test tasks, based on physical models of systems, processes and phenomena. The template of the class of physical tests for checking knowledge of the physical laws and abilities of transformations of a physical system is represented by a set of geometric drawings, diagrams, graphs of functional dependencies, a system of formulas for transforming physical values, templates of scenarios for changing the states of a physical system and a response template.

Each such template can be used both in generating similarity algorithms for specific multiple tests, and in algorithms for automatically checking the correctness of answers. The proposed method allows describing a relatively simple class of specific tests. An important feature of the system is the ability to automatically check not only the final answer, but also the parameters of the intermediate states of the physical system. The implementation of a procedural physical knowledge testing system can be performed by creating software interactive multimedia objects using the methods of computer mathematics and algebraic programming technology.

**Keywords:** physics test, mathematical models of test, test template, interactive multimedia object, algebraic programming technology.

## 1 Introduction

The teaching process of the exact sciences in secondary school, especially physics, includes both the lecture part of the lesson and the active teaching forms: practical works, double-acting works, independent and test papers, etc. Thus, it is necessary to control not only the declarative knowledge, but also procedural knowledge, that is, knowledge of methods for solving physical problems. General methods of constructing of computer mathematics systems for educational purposes, one of the subsystems

of which is the testing environment, are described in [1-10]. We adapted these methods to build a procedural physical knowledge testing system.

Physical tests, which will be discussed, are designed to control procedural knowledge of a physics course using the example of a physics course in the 7th-9th grades of the secondary school in Ukraine. Technologies for the control of procedural knowledge have not yet been studied and developed. Thus, the problem of research is relevant.

In [11] the general approach to the description of subject areas in mathematics and other exact sciences is described. In [12], a methodology was proposed for constructing systems for testing procedural mathematical knowledge and its refinement for constructing of a system for algebraic knowledge testing. In [13], a methodology for constructing systems for procedural mathematical knowledge testing and its refinement for building a system for geometric knowledge testing was proposed.

In this paper, within the framework of this general approach, the features of the construction of physical knowledge testing systems are considered. It is assumed that a testing system containing procedural physical tests will be implemented as a module *Physical Knowledge Testing Environment*, which can be used both in computer-aided educational mathematics systems (CAEMS) in physics and for other purposes.

The problem of the present work can be formulated as *a study of the functional requirements, mathematical models and algorithms for constructing of a system for testing procedural physical knowledge* in CAEMS.

Separately, it can be highlighted the task of designing and creating software environment testing of physical knowledge and skills. In this case, the actual need is to develop a software module for physical knowledge testing and skills in distance learning systems (DLS) [14].

The widespread use of distance learning in educational institutions in secondary and higher education was increased demands on the quality of distance learning. One of the main tasks is to improve the quality of distance courses, especially training modules of a practical orientation. There are testing systems, simulators, laboratory and practical works. The problem is that the international standards do not clearly spell out the specifications for the structure and implementation of such training modules. At the same time, an essential requirement for testing systems is the requirement of compliance with existing international standards of distance learning, which contributes to the integration of learning information resources. The problem of standardization of methods and technologies for developing a system of physical knowledge and skills testing is debatable and requires discussion of a wide range of specialists. In this paper, we consider methods for solving the problem of modeling and implementing of a module for physical knowledge and skills testing in distance courses based on *adaptive (laboratory) and template tests technology*, which is consistent with international standards IMS and SCORM [15, 16].

The relevance of solving the problem of designing of a module for physical knowledge and skills testing in distance courses is determined by the fact that the use of test types based on choice currently allows only knowledge control [17], but does not control skills, which is essential for the natural sciences.

## 2 Examples of formal models of physical processes

The subject area (ontology) is represented by structural-logical schemes (SLS). These ontologies are represented by a three-level hierarchy:

“Discipline” – “Educational Module” – “Model of Phenomenon, Process”.

Our approach is the system of test tasks should be unified within the framework of the discipline “Physics 7-9” [18]. However, its development is carried out in stages

PHYSICS 7 – PHYSICS 8 – PHYSICS 9 – ....

Before proposing a general definition of the pharma model of the physical process, we consider several examples.

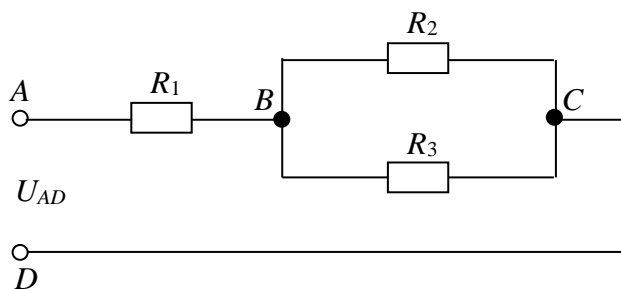
### 2.1 Example 1. Ohm's law for subcircuit.

From the program Physics 7-9: Ohm's law for subcircuit. Series and parallel connection of conductors.

The testing system should verify the application of the following physical laws:

1. The current strength  $I$  in the circuit is determined by the Ohm's law formula:  $I = U/R$
2. With a series connection of resistors, their total resistance is equal to the sum of their resistances:  $R = R_1 + R_2 + R_3 + \dots$
3. With parallel connection of resistors, their total conductivity (inverse of resistance) is equal to the sum of their conductivities:  $1/R = 1/R_1 + 1/R_2 + \dots$

**Test task.** The given scheme (Fig. 1)



**Fig. 1.** Test task on the topic of "Ohm's law for subcircuit".

Given:  $R_1 = 100 \Omega$ ,  $R_2 = 20 \Omega$ ,  $R_3 = 60 \Omega$ ,  
 $U_{AD} = 220 \text{ V}$

Find:  $I_{BC}$ ,  $R_{AD}$

**The formal circuitry model** should use

- model of resistor (resistance),



- model of the element (primitive) of the electrical circuit (EC),
- circuit model as a connection of elements.

**Models** of resistance, current strength, voltage are the models of physical quantities. A model of a physical quantity is a five (name, unit of measure, range of values, step of change, value).

**The model of the EC element** (electrical circuit) is a data set:

- designation of connection point 1,
- designation of connection point 2;
- resistance model (resistor);
- current strength model;
- voltage model.

The EC model is defined as follows: for circuit elements  $\sigma_1, \sigma_2, \dots, \sigma_k$  the scheme  $\Sigma$  is a formula for the variables  $\sigma_1, \sigma_2, \dots, \sigma_k$  in the signature  $\langle +, \parallel \rangle$ , where “+” is the sign of the serial connection operation, “||” is the sign of the parallel connection operation with consistent notations of beginnings and ends. For example, the formula of the circuit in Figure 1 is  $\Sigma = \sigma_1 + (\sigma_2 \parallel \sigma_3)$ . Here, the primitives are the following EC elements:

$$\sigma_1 = (A_1, B_1, R_1, I_1, U_1), \sigma_2 = (A_2, B_2, R_2, I_2, U_2), \sigma_3 = (A_3, B_3, R_3, I_3, U_3), \quad (1)$$

In the circuit model it is natural to distinguish subcircuits. In general, the relation “circuit – subcircuit” is determined through one (any) of the circuit construction operations: if  $F(x_1, \dots, x_n)$  is a circuit construction operation, and  $\Sigma_1, \dots, \Sigma_n$  is a circuits, then  $\Sigma = F(\Sigma_1, \dots, \Sigma_n)$  is a constructed circuit and  $\Sigma, \Sigma_j$  are in a “circuit-subcircuit” relationship. In this example, three primitive subcircuits are defined:

$$\sigma_1 = \langle \_R1\_ \rangle, \sigma_2 = \langle \_R2\_ \rangle, \sigma_3 = \langle \_R3\_ \rangle, \quad (2)$$

as well as constructions

$$\Sigma_1 = \langle \_ \sigma_2 \parallel \sigma_3 \_ \rangle, \Sigma = \langle \_ \sigma_1 + \Sigma_1 \_ \rangle \quad (3)$$

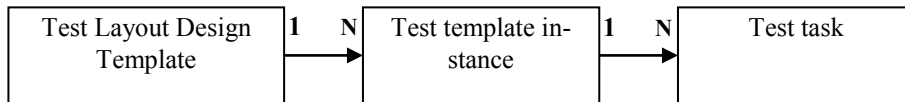
For each subcircuit, as well as for primitive subcircuits, variables  $R, I, U$  (1) are defined, and also meta variables – the points of connection of subcircuits into circuits. In (2), (3) these points are marked with an underscore. So any scheme  $\Sigma = (A_\Sigma, B_\Sigma, R_\Sigma, I_\Sigma, U_\Sigma)$ . Connection points of subcircuits are denoted by letters – the values of metavariables. The data that is included in the sections *Given* and *Find* in Test task, is displayed using these symbols. The notation can be simplified, but we do not give a simplification mechanism (see Fig. 1).

**Test generation method:** The scheme construction mechanism is called as *the test design template*.

A set of subcircuits (for example, (2) and (3)) is called as *instance of a test template*.

The test task generation method is carried out in three stages (Fig. 2):

1. The test task generation begins with the use of a construction template to obtain a specific instance of the test template.
2. The construction of a set of test template instances can be done pre-by (see the *Difficulty of the test task*)
3. The test task is generated from the test template instance by selecting the variable sections *Given* and *Find*, as well as randomly generating the values of variables of the section *Given*.



**Fig. 2.** Stages of the test task formation (on the topic of Ohm's Law for the subcircuit).

The test task generation is now carried out by selecting the test template instance schema, randomly selecting variables and their values for the *Given* section, as well as randomly selecting the names of other variables for the *Find* section.

**Test's Complexity.** The complexity of the model and the test, including the level of computational complexity, is determined by the number of characters of operations in the formula of the test template instance. For the scheme of this level of complexity, the complexity of the actual test task is also determined based on the number of quantities in the *Find* section.

The presented example should be considered rather complicated, since the formula contains two signs of operations.

To limit the complexity, it is proposed to limit the maximum complexity of the circuit. In the example, this maximum can be schemes with three operation signs.

For each difficulty level, it is easy to write out all the schemes (test template instances) of a given difficulty level and a test exercise for this model can now be defined as a set of test tasks with a given distribution of difficulty levels.

## 2.2 Example 2. Mixing liquids' model.

The elementary process of mixing liquids can be described as follows: two vessels contain liquids, the physical characteristics of which are given by the heat capacities  $c$ , the temperatures  $t$  of the masses  $m$ . It is required to determine the physical characteristics of their mixture contained in the third vessel (Fig. 3).

As in the first example, the formal model of a physical quantity is a five (name, unit, range of values, step of change, value).

In the definition of a fluid mixing model, formal models of such physical quantities are used: heat capacity, temperature, mass, heat.

*Formal fluid model:* heat capacity  $c$ , temperature  $t$ .

*The formal model of a vessel with a liquid* is an element of the scheme: a model of a liquid, mass  $m$ .

*The formal model of mixing liquids* uses formal models of vessels with liquids  $(c_1, t_1, m_1)$ ,  $(c_2, t_2, m_2)$ ,  $(c_3, t_3, m_3)$ .

The testing system should verify the application of the following physical laws:

$$m = m_1 + m_2, \quad (4)$$

$$Q = Q_1 + Q_2 \text{ (heat balance equation),} \quad (5)$$

where

$$Q_1 = c_1 m_1 (t_1 - t), \quad Q_2 = c_2 m_2 (t_2 - t) \quad (6)$$

$$c = \frac{c_1 m_1 + c_2 m_2}{m_1 + m_2} \quad (7)$$

$$t = \frac{c_1 m_1 t_1 + c_2 m_2 t_2}{c_1 m_1 + c_2 m_2} \quad (8)$$

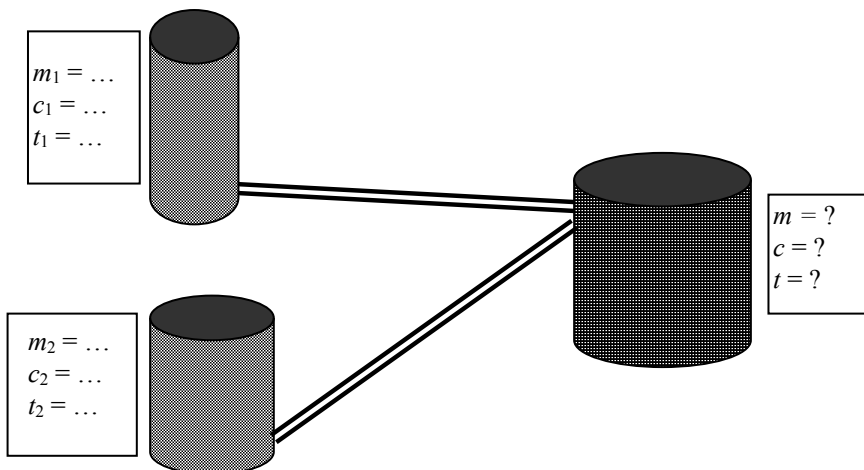


Fig. 3. Test task on the topic of "Mixing liquids".

### Formal model

*Physical quantities:*

Mass = (Real, kg, [1; 100], 1),

HCap = (Real, J / kg · ° C, [0.2; 20], 0.2),

Tem = (Real, ° C, [10; 100], 1),

*Element of the model* L = (Mass, HCap, Tem),

*Schematic construction operation:* L = L<sub>1</sub> + L<sub>2</sub>, or L = Mixt(L<sub>1</sub>, L<sub>2</sub>)

### Examples of test tasks:

Example 1

*Given:*

L<sub>1</sub>(m<sub>1</sub>, c<sub>1</sub>, t<sub>1</sub>), L<sub>2</sub>(m<sub>2</sub>, c<sub>2</sub>, t<sub>2</sub>).

L<sub>1</sub> = ((2 kg), (4.19 · 10<sup>3</sup> J / kg ° C), (15 ° C)) - H<sub>2</sub>O;

$$L_2 = ((1 \text{ kg}), (2.39 \cdot 10^3 \text{ J / kg } ^\circ \text{C}), (5 ^\circ \text{C})) - \text{C}_2\text{H}_5\text{OH};$$

*Find*

$$L = (m, t).$$

Example 2

*Given:*  $L_1, L_2$ ;

*Find*  $L_2$ .

**Method of test task generating.** As in example 1, the installation of mixing liquids can be considered as a sequential mixing scheme. If the operation of mixing two liquids is denoted by a symbol “+”, i.e. the scheme of example 2 is given by the formula  $L = L_1 + L_2$ , schemes are possible  $L = (L_1 + L_2) + L_3, L = (L_1 + L_2) + (L_3 + L_4)$ .

In this case, the test task is generated:

- selection of a test construction template;
- random selection of the type of template from the list of liquids;
- random test generation by generating data from the *Given* section and the names of the *Find* section.

**Test complexity.** As in example 1, the complexity of the test task is determined by the complexity of the scheme - the design template, i.e. the amount of mixed liquids. You can mix 2, 3 and even 4 substances according to the following schemes:

$$(1, 2), (1, 2, 3), ((1, 2), 3), (((1, 2), 3), 4), ((1, 2), (3, 4))$$

The complexity of the construction template makes sense to specify a discrete probability distribution. For example:

**Table 1.** Test task template.

Scheme	(1, 2)	(1, 2, 3)	((1, 2), 3)	(((1, 2), 3), 4)	((1, 2), (3, 4))
Probability	0.5	0.2	0.2	0.05	0.05

In addition, for this particular example, the complexity of the test task is influenced by the fact whether two identical or two different liquids mix with different heat capacities. As in example 1, the complexity of the test task is determined by the complexity of the construction template, the amount of data in the *Find* section, taking into account the number of different mixable liquids.

### 3 Formal model of physical knowledge testing system

#### 3.1 The course of the discipline "Physics"

is represented by a hierarchy of dependence of the subject (training) modules (structural-logical scheme of the discipline).

- 3.1.1 In the training module, a list of the intrinsic physical quantities used in it is defined (Fig. 4). Each physical quantity is defined by a five:  
(*name, basic physical dimension, type of value, range of values, step of change*)

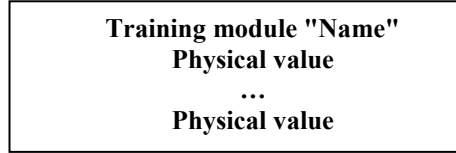


Fig. 4. Model of the training module.

3.1.2 Relationship dependence determines the sequence of study of relevant topics of the training course (Fig. 5).

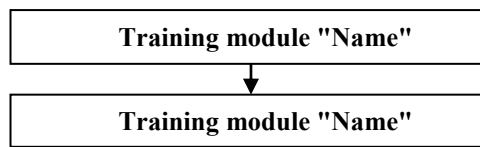


Fig. 5. Model of hierarchical relations of dependencies of training modules.

3.1.3 In addition to the attributes described in 4.1.1, the training module is represented by a set of formal models of physical phenomena and processes (Fig. 6).

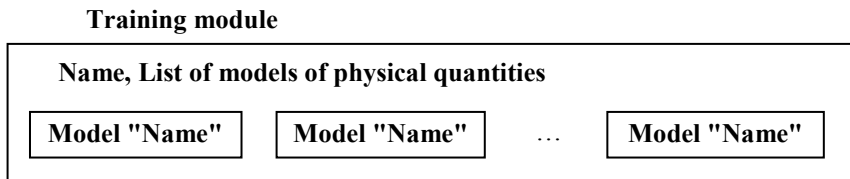


Fig. 6. Model of a subject module as a set of models of phenomena, processes.

### 3.2 The formal model of a physical phenomenon, a process

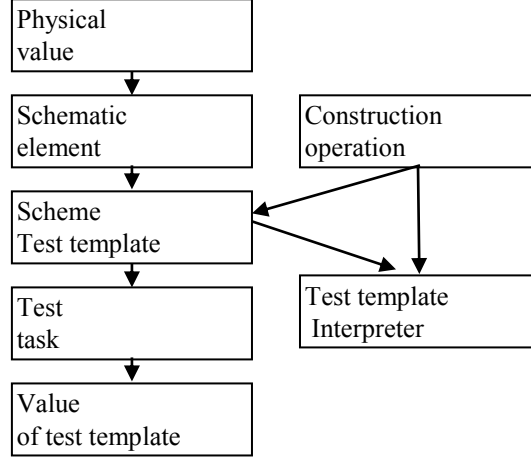
The formal model of a physical phenomenon, a process is a scheme (formula) in the signature of the operations of constructing schemes, a list of types of elements of the scheme, a set of interpreters of operations for constructing a scheme (Fig. 7).

*Physical value* is defined as the five attributes:

*(Name, type of value, physical dimensionality, range of values, step of change)*

*The element of the scheme* (primitive scheme) is a set of physical quantities. Thus, if  $\sigma$  is an element of the, and  $a_1, \dots, a_l$  are physical quantities, then  $\sigma = (a_1, \dots, a_l)$ . The schema element has its own type:  $Type(\sigma) = (type(a_1), \dots, type(a_l))$ . If  $x_1, \dots, x_l$  – variables are physical values, then a structured variable  $\sigma = (x_1, \dots, x_l)$  is a scheme element.

*Scheme construction operations.* Each scheme is composed of scheme elements and other schemes using construction operations. The set of names and arity of construction operations is called the schema signature:  $OP_{\Sigma} = \langle f_1^{(k_1)}, \dots, f_m^{(k_m)} \rangle$ .



**Fig. 7.** The system of categories for the formal model of a physical phenomenon, process.

The construction operations are, generally speaking, multi-sorted. If  $y = f_i(x_1, \dots, x_{k_i}) \in OP_\Sigma$ , then the types of variables  $y, x_1, \dots, x_{k_i}$  belong  $TP_\Sigma$  and, generally speaking, are different. The types of operations for constructing schemes are determined by the types of variables  $y$ .

*Test schemes (templates)* are constructed from the elements of schemes and other schemes using construction operations:  $\Sigma_{f_i} = f_i(\sigma_1, \dots, \sigma_{k_i}) \in$ . Thus, the test template  $\Sigma$  is the formula in the signature  $OP_\Sigma$ . All the arguments of the schema  $\Sigma$  are the variables — the schema elements. Thus, the template (formula scheme) has the form  $\Sigma(x_1, \dots, x_l)$ .

The complexity of the scheme is the number of symbols of functions in the formula  $\Sigma$ . Since the value of any function for a given variable requires computation, the concept of the computational complexity of a scheme is closely related to the concept of the complexity of a scheme.

*The test task* is obtained as a schema specification with the values of some subset of the set  $(x_1, \dots, x_l)$ . The test task has the form  $\Sigma(a_1, \dots, a_k, x_{k+1}, \dots, x_l)$ . Values  $a_1, \dots, a_k$  form *Given* section of the test task. In the simple case, *Find* section contains the names of one or more variables from the set  $(x_{k+1}, \dots, x_l)$ .

*The test template interpreter* is a software function that calculates the value of a scheme given the values of its arguments. Let  $\sigma(x_1, \dots, x_l)$  be an any element of the scheme. Variables  $x_1, \dots, x_l$  are related by relationships  $\Phi(x_1, \dots, x_l)$  — physical laws whose knowledge is being tested. Therefore, all values  $(x_{k+1}, \dots, x_l)$  of the *Find* set variables can be calculated by values  $a_1, \dots, a_k$ . Thus, for any type scheme  $f(\Sigma_1, \dots, \Sigma_l)$ , its value  $y = Value(f(\Sigma_1, \dots, \Sigma_l))$  can be calculated from bottom to top:

$$a_1 = Value(\Sigma_1), \dots, a_l = Value(\Sigma_l), y = Int f(a_1, \dots, a_l),$$

where *Intf* is the interpreter of signature operation  $f$ .

Thus, the interpreter of the scheme calculates not only the values of the variables of the set  $(x_{k+1}, \dots, x_l)$ , but also all the physical values of any subscheme of the test template.

Thus, the number of test case variables includes not only variables  $x_1, \dots, x_l$ , but also all intermediate variables of a form  $y = f(x_1, \dots, x_l)$  for any subschem of a type  $f(\Sigma_1, \dots, \Sigma_l)$ .

## 4 Methods for generating and validating test items

### 4.1 Test template selection

In principle, there are two approaches to solving the problem of choosing a test pattern. First, for each model of the physical process, the phenomena are created manually by the table of templates (see tab.2), which are stored in the database. With this approach, together with the table of templates, it makes sense to keep a table of the distribution of probabilities for choosing this template. Secondly, it is possible to implement an algorithm for automatically generating circuits of a given complexity. In this case, first with a given probability, the level of complexity is selected, and then a circuit of this complexity is generated. Each of these approaches has its own advantages and disadvantages. In the first case, you need to spend a lot of time filling the database with template tables. In the second case, time is spent on the implementation of an algorithm for automatically generating a circuit of a given complexity.

Another technological challenge is to implement a graphic image of the physical process, the phenomenon. The test window contains the fields *Picture*, *Given*, *Find*. The *Picture* field displays the scheme in which variables are marked. Fields *Given* and *Find* are filled in at the stage of test task generation. The uniqueness of the model leads to the fact that each drawing scheme is programmed separately.

### 4.2 Test generation

Let be the test pattern template. Consider a set of schemes of a given circuit containing all elements and all composite schemes  $\Sigma = \langle \Sigma_1 = \sigma_1, \dots, \Sigma_k = \sigma_k, \Sigma_{k+1} = \sigma_l \rangle$ . Each element of this set depends on the variables - physical values:  $\Sigma_1(x_{11}, \dots, x_{1n}), \dots, \Sigma_l(x_{l1}, \dots, x_{ln})$ . As already mentioned, for each subscheme  $\Sigma_j(x_{j1}, \dots, x_{jn})$  the following property takes place: if the values of any  $m$  variables from the set  $(x_{j1}, \dots, x_{jn})$  are known, the values of the other  $n - m$  variables can be calculated. Therefore, the process of calculating the data values of a particular test task is carried out from the bottom up to the structure of the circuit.

Our approach to growing the practical knowledge testing system is as follows:

1. On the basis of algorithmic analysis, define a specific subject area as a set of models of physical quantities, models of elements of schemes and schemes as formulas in a given signature.
2. Develop a unified general model of this class (test pattern design), as well as test pattern templates as an implementation of the test pattern design

3. Implement the algorithms for generating conditions and responses to this model pattern, thereby determining the algorithm for generating a test task and verifying it
4. Develop CASE-technology for describing subclasses of test items based on a single common model for users of the computer-aided mathematics system for educational purposes.
5. Develop common mechanisms for storing and invoking algorithms for generating specific test items.
6. Develop methods for generating and validating test items.

## 5 Test template selection

IMS QTI standard specifications allow you to develop a model and create software for testing physical knowledge and skills in the DLS. For this purpose, specifications of Adaptive Items and Item Templates [16] can be used.

### 5.1 Adaptive test items

The software module for creating and executing test tasks for testing physical knowledge and skills can be based on the technology of developing adaptive tests. The IMS QTI version 2.2 specification provides support for adaptive tests in distance learning systems. In accordance with this standard, adaptive test questions may contain software object modules that provide interactive user interaction with them. For such questions, we introduce into consideration a new type of test question — an object type, and tests containing object-type questions will be called adaptive (laboratory) tests. Below is the specification and schema of the attributes of the object type question of the adaptive (laboratory) test (Fig. 8) [19].

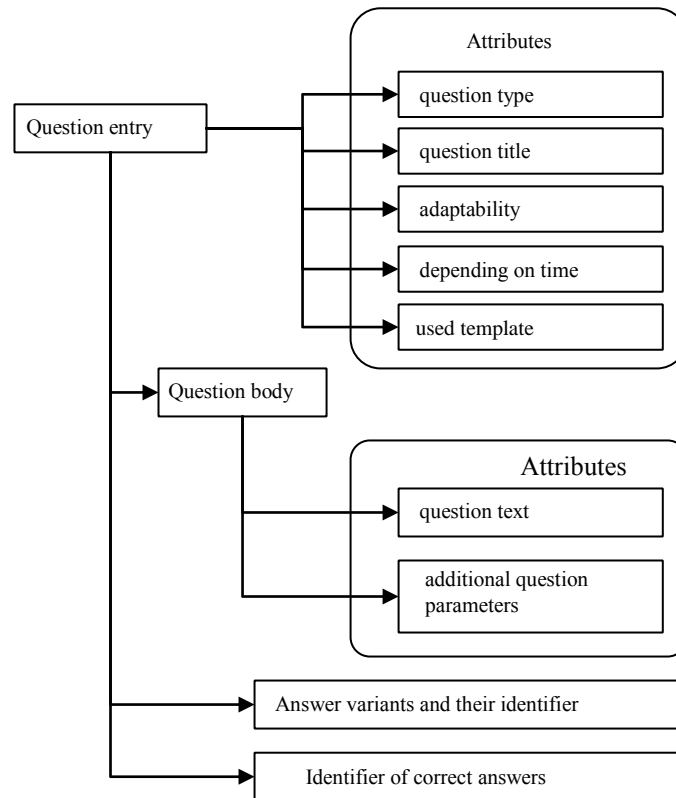
Each type of question separately has its own characteristics in the specification. This is due to differences in the parameters of these types.

The response of the test is processed in the Response Processing module. Evaluation of the answer in the module can occur in two ways: a differentiated assessment of the entire question and the accumulation of evaluation of the response options.

According to the IMS QTI Specification, when working out questions of the adaptive test, there is a feedback with the test person, determining the response adjustment at each stage and thus forming the variability of the response. In this question there may be additional parameters that are not specified by the standard. An example of the implementation of such an object question is a controlled interactive Flash animation in which a specific task is programmed [19]:

- module initialization with some input parameters,
- interactive game situation in which the tested person participates,
- output as a result of the action of the test.

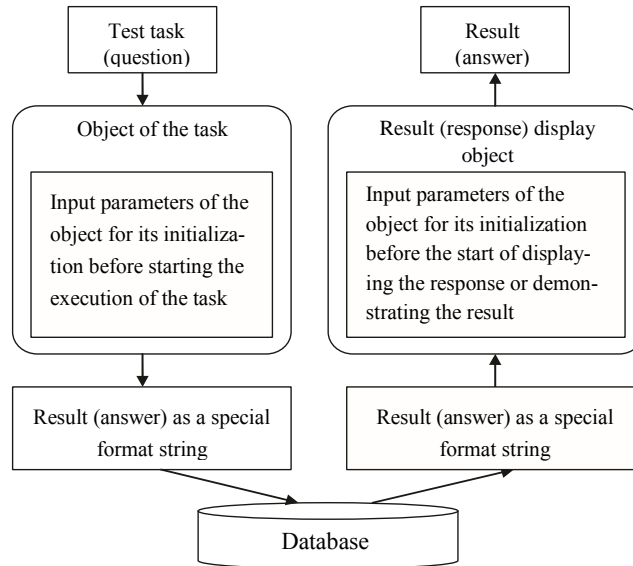




**Fig. 8.** The question attributes scheme of the object type of the adaptive test and its specification.

The result of answering a question of a laboratory (adaptive) type can be determined in the test passing object, taking into account the value of the maximum mark for correct passing the test, and used in automatic (software) assessment. Alternatively, the score can be determined (changed) by the tutor during the check.

Due to the lack of a separate specification of the IMS standard for laboratory (adaptive) tests, we consider the method of their simulation, which consists of the following. Two object modules are developed that are interconnected by a special format data transfer interface. The first module (the test passing object) is designed to pass a laboratory (adaptive) type test, and the second (answer display object) is intended to reflect the test passing results during the test. The scheme of interaction between the objects of the testing module and the database is shown in Fig. 9.



**Fig. 9.** The scheme of interaction between the objects of the test module and database.

Object modules can be Java applets, COM objects (for example, Adobe Flash) or HTML 5 program objects, which upon initialization receive the values of input parameters (attributes) and are set up in a working state. For an object passing the test, such parameters may be the value of the maximum mark for correct passing the test, the value of the time limit for passing the test, other values of the object initialization parameters; for the response display object, the values of the input parameters that ensure the initial state of the object, corresponding to the final state of the test object.

Thus, the combination of two object modules forms a closed system for passing, checking and evaluating tests of the adaptive (laboratory) type. The proposed method of creating adaptive (laboratory) type tests meets the specifications of the IMS standard and allows packaging for portability in other distance learning systems.

## 5.2 Template type test items

At developing of the testing module, we will understand the testing process as a sequence of calls of operators with a certain behavior in the context of a learning model.

The process of automatic test assembly in the DLS testing module is a workflow in which certain logic is implemented with the possibility of automation. It is important to begin by defining an abstract model that contains all the necessary data describing the purpose of training and explaining the correlation between objects of specific instances of this model in order to automate the compilation of test questions as a workflow.

Suppose Item Templates is an instance of a test task generated by this template with the automatic test generation process described above.

Automatic generation of Item Templates will help to significantly simplify the preparation of practical tasks, reducing the time for their creation and ensuring the unique nature of each generated task. It will also provide an opportunity to automate the evaluation of test results without the negative impact of the human factor.

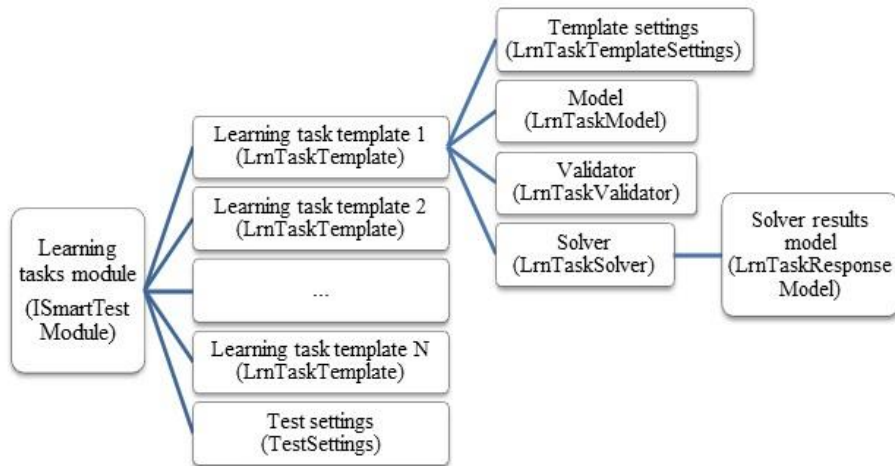
We define the test as a set of learning tasks set and test settings:  $ST = \langle S(S_1, \dots, S_L), T(T_1, \dots, T_N) \rangle$ , where  $S(S_1, \dots, S_L)$  – a set of test settings, defined by a user (a test compiler), and  $T(T_1, \dots, T_N)$  – a set of learning tasks. To build the abstract model of the learning task  $T$  we use its signature of following view:

$$T = \langle M, P, Q \rangle,$$

where  $M$  – a set of the task input parameters, and is described as  $M(X_1, \dots, X_n)$ , where  $X_1, \dots, X_n$  – the task parameters;  $P$  – a set of the task conditions, described as  $P(P_1, \dots, P_k)$ , where  $P_1, \dots, P_k$  – task conditions;  $Q$  – the task result model, described as  $Q(Q_1, \dots, Q_m)$ , where  $Q_1, \dots, Q_m$  – sets of metadata, defining the results of the task. We introduce the following software modules to describe the Item Templates object: LrnTaskTemplate (abbreviated from Learning Task Template) for  $T$ ; LrnTaskModel (abbreviated from Learning Task Model) for  $M$ ; LrnTaskValidator (abbreviated from Learning Task Validator) for  $P$ ; LrnTaskModel for  $Q$ .

The abstract generator model is a generalized model of math tests. The scheme of interrelations of the objects described above is shown in Figure 10.

According to this scheme, ISmartTestModule is a library of learning task generator templates for compiling a test task. The template library of the instructional task generator module is a program class (LrnTaskTemplate), which contains all the functions necessary for building learning task instances, validating and solving them using a named model. The functions of the task generator template use the common (TestSettings) and local (LrnTaskTemplateSettings) user-defined settings (the test compiler) as input parameters. These settings can provide the template with parameters for generating and checking specified learning tasks in the form of: instructions for using preferred question types [17], the number of generated answers, fine-tuning the module with the inclusion / exclusion of certain templates, input parameter fields, etc. Number of such settings may differ depending on the module and its templates. It is expected that the test compiler will adjust the parameters when adding Item Templates to the system. The learning task model (LrnTaskModel) is a program class for storing the input parameters of the learning task. Depending on the goals, the model of the training task may contain extended attributes necessary to describe the parameters of the task. The number of parameters is not limited by the system. The next element of the learning task generator is the LrnTaskValidator class. The purpose of this program class is to check the compliance of the model instance with the task settings. The solver (LrnTaskSolver) is the last element of the template. The solver's task is to solve the specified task (to achieve results) using the LrnTaskModel parameters with the conditions specified in the LrnTaskValidator. The results of the solver are formal expressions in the signature of a specific subject field, which can be defined in the heir to the LrnTaskResponseModel class. In particular, there can be atomic expressions – numbers, strings, dates.



**Fig. 10.** Scheme of interrelations of elements of model Item Objects.

## 6 Conclusions and Outlooks

The approach to building a system for practical physical knowledge testing described in this paper allows you to:

1. Quickly and correctly draw up a system of tests for practical knowledge testing on a given topic, in accordance with a given level of computational complexity of this system.
2. Automate the procedure for generating a sufficiently large number of specific test tasks based on a single template.
3. Solve the problem of automatically checking the correctness of the answer and the progress of the test solution.
4. Solve the test task step by step, applying symbolic expressions and checking at each step the correctness of their use.
5. According to the proposed model, develop software for physical knowledge and skills testing.

The proposed approach to the process of physical knowledge and skills testing can be used to build a model and develop software for a testing module in a distance learning system in accordance with the requirements of international standards IMS and SCORM.

## References

1. Lvov M.S. The basic principles of the construction of pedagogical software support practical training. *Control Systems and Computers*, № 6, P. 70-75 (2006)
2. Lvov M.S. Designing a logical inference as a step-by-step solution of problems in mathematical systems for educational purposes. *Control Systems and Computers*, № 1, P. 25-32 (2008)
3. Lvov M.S. The concept of information support for the educational process and its implementation in pedagogical software environments. *Control Systems and Computers*, № 2, P. 52-57 (2009)
4. Lvov M.S. The concept, architecture and functionality of a flexible distributed program environment for educational purposes for secondary schools. *Workplace of the Methodist. Control Systems and Computers*, № 6, P. 71-78 (2009)
5. Lvov M.S. Distributed software environments for educational purposes. Subsystem of educational process management. *Control Systems and Computers*, № 1, P. 66 - 71 (2010)
6. Lvov M.S. Synthesis of interpreters of algebraic operations in extensions of multi-sorted algebras. *Bulletin of Kharkiv National University (Series "Mathematical Modeling - Information Technologies - Automated Control Systems")*. No. 847, P. 221-238 (2009)
7. Lvov M.S. Mathematical Models and Methods of Supporting the Settlement of Educational Problems in Analytical Geometry. *Artificial Intelligence*. No. 1, P. 86-92 (2010)
8. Lvov M.S. Trigonometric computations in computer mathematics systems for educational purposes. *Artificial Intelligence*, № 4, P. 417 – 423 (2011)
9. Lvov M.S. On one approach to building a system for testing geometric knowledge. *Journal of Information Technologies in Education. Kherson*, № 18, P. 42 - 50 (2014)
10. Lvov M.S., Shishko L.S., Chernenko I.E., MS On the organization of control of knowledge as a feedback in systems of computer mathematics of educational assignment. *Journal of Information Technologies in Education. Kherson*. No. 16, P. 29 - 42 (2013)
11. Lvov M.S. Mathematical models of subject areas in computer mathematics systems for educational purposes. *Bulletin Harkiv national university. (Series "Mathematical modeling. Information technologies. Automated control systems")*. № 987. P. 46 – 60 (2011)
12. Lvov M.S. Mathematical tests in computer math systems for educational purposes. *Control Systems and Computers*, №6. P. 60 – 67 (2011)
13. Lvov M.S. Intellectual properties of computer mathematics systems for educational purposes and methods for their implementation. *Artificial Intelligence*, № 2, P. 45 – 52 (2011)
14. Peter Brusilovsky and Philip Miller. Web-based Testing for Distance Education. In: *Web-Net 99 World Conference on the WWW and Internet Proceedings (Honolulu, Hawaii, October 24-30, 1999)*, 7p.
15. Available at: <http://www.contrib.andrew.cmu.edu/~plb/papers/WebNet99.html>
16. H. Kravtsov, D. Kravtsov. Knowledge Control Model of Distance Learning System on IMS Standard. *Innovative Techniques in Instruction Technology, E-learning, E-assessment, and Education*. Springer. P. 195 – 198 (2008)
17. IMS Question & Test Interoperability (QTI) Specification. Version 2.2. Available at: <http://www.imsglobal.org/question/index.html#version2.2>
18. GRE(R) Physics Test Practice Book. Educational Test Service (2017). Available at: [https://www.ets.org/s/gre/pdf/practice\\_book\\_physics.pdf](https://www.ets.org/s/gre/pdf/practice_book_physics.pdf)
19. Physics, grades 7-9. Educational program for general educational institutions. Available at: <https://mon.gov.ua/ua/osvita/zagalna-serednya-osvita/navchalni-programi>  
Kravtsov H., Kravtsov D. Adaptive and object tests in the model of knowledge control according to the IMS standard. *Control Systems and Computers*, № 1, P. 42 - 48 (2008)

# Increase of the Level of Graphic Competence Future Bachelor in Computer Sciences in the Process of Studying 3D modeling

Hanna Chemerys <sup>[0000-0003-3417-9910]</sup>, Kateryna Osadcha <sup>[0000-0003-0653-6423]</sup>,  
Viacheslav Osadchyi <sup>[0000-0001-5659-4774]</sup> and Vladyslav Kruhlyk <sup>[0000-0002-5196-7241]</sup>

Bogdan Khmelnsky Melitopol State Pedagogical University,  
Hetmanska str.20, 72300, Melitopol, Ukraine  
{Chemeris, okp, osadchyi}@mdp.u.org.ua, krugvs@gmail.com

**Abstract.** The article deals with the examination of distinct aspects of the application of 3D modeling technologies as the promising trend, which found its application in the process of creation of models for 3D printout, virtual and augmented reality, in the process of development of gameplays, in modeling of objects for educational aims etc. The urgency of the study of the 3D model processing considering the conditions by bachelors of computer sciences, nominated by competitive environment of labour market has been defined. The necessity of improvement of methods of graphical discipline teaching and the actuality of the introduction of the study of 3D modeling technologies in the process of professional training of future bachelors of computer sciences as a promising trend considering the demands of labour market and as the factor raising the level of student motivation to a professional activity in general and the formation level of graphical competence in particular have been grounded. The methodological support of the course has been described, the aim and content of the study of the “Computer Graphics” discipline have been presented. The structure and the content of theoretical and practical parts of the course have been provided, which are oriented to the use of the 3D graphical Autodesk Maya processor. The algorithm has been examined and the stages of creation of organic form objects have been described on the example of modeling of game characters and the algorithm of creation of 3D surroundings on the example of modeling of the game level interior. The certain aspects of informational and communicational support of the “Computer Graphics” course have been examined, within the frames of which the approbation of the developed educational and methodological complex has been performed.

**Keywords:** future bachelor of computer sciences, computer graphics, 3D modeling, game characters, game surrounding.

## **1 The introduction**

### **1.1 The problem statement.**

The modernity is characterized by extensive computerization in almost all spheres of the social life. Computer graphics gains its advancement in the creation of photo-realistic virtual images, it is used in 3D print technologies, in the modeling of the objects for virtual and augmented reality, in the process of development of gameplay, in the modeling of objects for educational aims, in the performance of complicated graphical projects and many other spheres of people lives. The progressive development of informational and communication technologies has influenced to the advancement of computer games, which became the integral part of everyday lives of majority of people. As it was noted by N. Marenich, the usage of graphics in the quality of processing of visual components of computer games has the rich history, beginning from the traditional pixel graphics and finishing with the leading progressive and prospective technologies of polygonal graphics, capable to create detailed 3D objects [1]. The prerequisite of special requirements to the professional training of future bachelors of computer sciences under the conditions of competitive environment has been the fact that skilled specialists in the sphere of game design have the competitive salaries and often are the most well-paid professionals in the industry of games production. Taking into account the swift growth of demand for highly skilled specialists in the industry of game design and developers of surrounding for virtual and augmented reality [2] the high level of motivation of students to the study of the methods of computer graphics has been observed, in particular 3D modeling, that in its turn raises the role of graphical competence in the modern system of education of future bachelors of computer sciences [3]. Thus, the question of revision of the content and methods of teaching of the number of disciplines stands now, which is aimed at the formation of graphical competence of future bachelor of computer sciences, that is grounded by the researches of needs of contemporary labour market and thus is actual.

### **1.2 Problem state of the art.**

Aesthetic aspects of an art project activity, to which the 3D modeling refers, have been considered in the research of V. Bychkov, E. Iljenkov. The distinct factors of the development of spatial thinking have been studied by such scientists as N. Bondar, I. Nishchak, A. Rajkovskaya, Y. Feshchuk. The formation of graphical knowledge and skills with the help of informational technologies have been grounded by P. Buyanov, M. Ozga, A. Glazunova, R. Gorbatyuk, M. Kozyar, V. Kodratova, N. Polishchuk, Y. Ramskyj, I. Semenov, M. Yusupova. The methods of work with 3D modeling software have been highlighted in works of D. Banakh, T. Bordman, G. Greham, M. Dzambruno, J. Johns and others. The issue of 3D modeling also has found its reflection in the research of I. Bratchikov, T. Bulyanitsi, V. Goncharova, T. Koroteeva, T. Nikitina, I. Popova, E. Romanycheva and others. The biggest number of researches in the theory and methods of teaching of 3D modeling of students of

“Computer sciences” specialty have been investigated in foreign publications [4, 5, 6, 7, 8]. In the overwhelming majority of studies of the methods of training of 3D modeling the attention has been paid to engineering graphics by means of CAD-systems for the training of students of technical specialties. But the researches, devoted to the methods of 3D modeling training for the students of IT-specialties, namely the modeling of 3D objects for gameplay or for virtual (VR) or augmented reality (AR), have not been studied sufficiently, thus this issue needs particular attention and thorough scientific research.

**The aim of article is the research of effectiveness of introduction of methods of 3D modeling training in the content of “Computer graphics” discipline for the formation of components of graphical competence of future bachelors of computer sciences.**

## **2 The results of research**

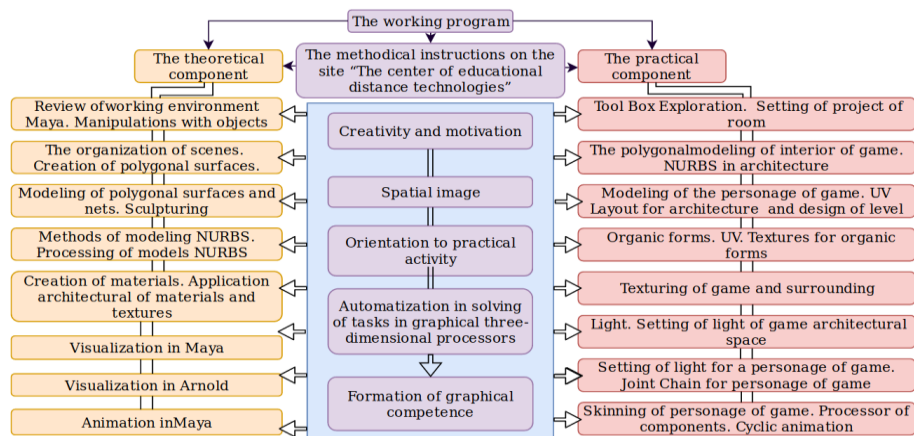
### **2.1 The description of educational and methodological complex on “Computer graphics”**

The study of the methods of 3D modeling in the process of mastering disciplines, forming the graphical competence, needs the developed spatial thinking, an aesthetic taste, a creative approach and analytic thinking, an exclusive sense of composition, the skills to perceive and produce graphical content, that is caused by the specificity of the discipline. All the qualities of a creative personality mentioned above, as any other ability of a person, are to be and can be developed. Not only perfect knowledge of disciplines of the professional cycle, aimed at the development of skills of programming in various languages influences on the level of professional training of future bachelor of computer sciences, but also the formation of graphical competences. The specialists in the field of computer sciences have to demonstrate the integration of technical, informational and designer skills [9]. At the same time with the mastering of contemporary graphic processors, including the means of 3D modeling, the process of formation of the graphical competence of future bachelors of computer sciences stipulates the acquisition of stable motivation for the usage of 3D processors by students; mastering of skills, ensuring the effectiveness of a professional activity under the conditions of the modern competitive surrounding; the development of creative orientation of the professional activity and critical thinking; the constant work on the increase of professional level; the aspiration for self-education and self-perfection. Modern computer graphical processors, specializing in the 3D modeling, have at their disposal the opportunities of 3D parametric modeling, have big libraries of standardized objects, logical operators and built-up languages of programming. With the aim of formation of graphical competence of future bachelors of computer sciences, the educational and methodological complex has been developed, based on the study of the 3D modeling technology, the approbation of which has been performed in the process of studies of the “Computer graphics” discipline for the students learning the “Computer sciences” speciality. The “Computer graphics” discipline according to the curriculum is studied during the fifth semester. For its study 5 credits ECTS are given,



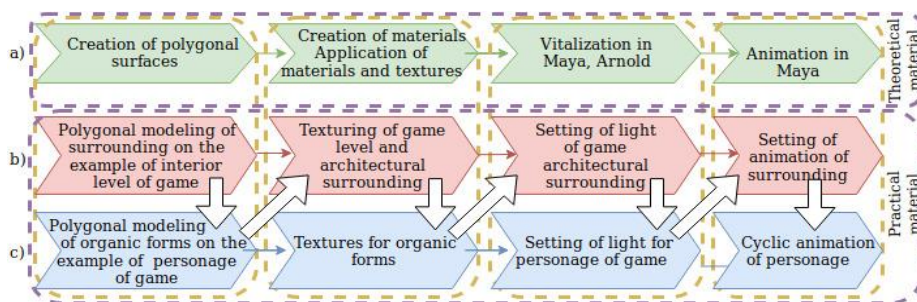
from which 16 hours are devoted to the lecture material, 30 hours are dedicated to lab work and 104 hours to student self-study. The aim of the study of the “Computer graphics” discipline is the acquaintance of students with the peculiarities of modeling, texturing, rendering and animation. For the selection of the content of the course the analysis and the selection of software for 3D modeling have been undertaken [2], according to the results of which for the study of students the 3D graphical Autodesk Maya processor has been chosen, the license for which the Autodesk company has been provided free of charge for three years for the usage at educational institutions. Maya has a powerful toolset for 3D modeling, it fully satisfies the qualifying standards for the development as game characters and also the modeling of game surrounding, that allows to create 3D models of any complexity level [10].

The tasks of study of the “Computer graphics” discipline are the expansion of imagination of students about the purpose and opportunities of the programs of creation of computer graphics and animation; providing for the students the necessary knowledge about 3D modeling; the formation of skills and abilities of students on the creation and application of 3D graphics and animation on the examples of projecting of game characters, surrounding for game levels and the creation of 3D scenes with the usage of the light source; the demonstration of practical significance and orientation of received knowledge and skills in the future professional activity. The obtained knowledge and skills can be used for the further independent study of more complex modes and methods of work in the professional programs of 3D graphics processing, such as 3D Studio Max, ZBrush, Cinema 4D and others. The structure and content of educational methodical complex are represented in the illustration. (see Fig.1). While the development of the methods of study of 3D modeling in the content of the “Computer graphics” discipline with the aim of formation of components of the graphical competence of future bachelors of computer sciences, the training of students in the usage technology of a 3D graphical processor for modeling of game characters, game surrounding and modeling of game levels has been chosen to be the main idea. This allowed to take into account the development of professional competences of future bachelors of computer sciences (the study of the software functional for creation of computer graphics), also the mastering of competences, which are prospective considering the demands of the labour market (to acquire the skills of development of 3D models and surrounding for a gameplay, virtual and augmented realities and so on). The content of educational and methodological complex includes theoretical and practical modules, based on the technology of 3D modeling. Each lecture is accompanied with the demonstration of illustrative material, videos and other materials, which allows to organize systematically the educational material and to form the graphical competence of future bachelors of computer sciences.



**Fig. 1.** The structure and the content of educational and methodological complex of the “Computer graphics” discipline for future bachelors of computer sciences.

In the process of usage of obtained knowledge in the practical activity, students form the skills of work with technology of 3D modeling and the motivation for the study of disciplines of the professionally oriented cycle grows. The development of the practical part of the course is built in such a way to accumulate logically the complexity of the developed model, gradually study the model: starting with the development of the concept and projecting all details and images, the creation of structures, studying the texture of model, setting the light and finishing with animation of the model and its rendering. The logical structure of the practical part of the course is represented in the illustration 3, where the sequence of processing of practical lessons is demonstrated by white arrows (see Fig. 2).



**Fig. 2.** The theoretical material (a) and the practical material: the algorithms of modeling of 3D objects of an organic form on the example of the characters of the game (b) and space surrounding on the example of the interior of the game level (c)

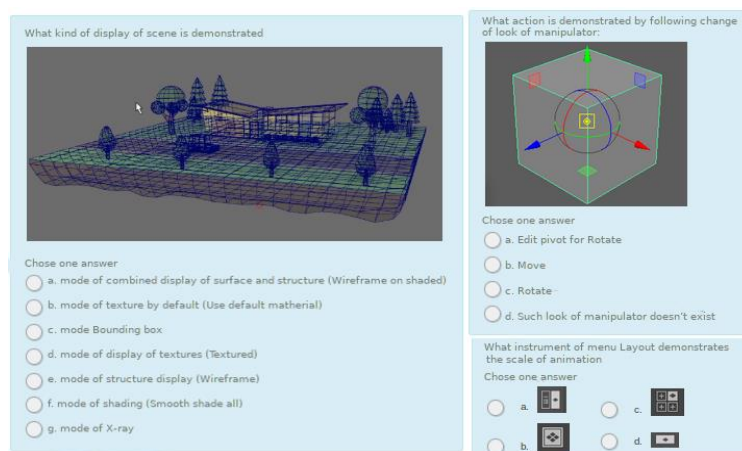
The result of processing of practical part is two complete 3D models – the model of the character and the example of space organization for a game level. Taking into consideration the necessity of the gradual increase of the complexity of processing of 3D objects, we offer the rotation of practical tasks: performing of every stage of algo-

rithm at first for the modeling of surroundings (as a less resource consuming stage) processing of this very stage of algorithm, but already for modeling of a character (as a more resource consuming one). Such study trajectory of 3D modeling technology is reasonable due to the fact that students in the course of such work during lectures learn the certain stage of modeling theoretically a), and further in the course of practical work they study two branches of modeling of objects simultaneously (personage b) and surrounding c)).

## **2.2 Description of educational and methodological complex of the “Computer graphics” discipline**

The application of information technologies in the education is called to serve the increase of quality, effectiveness and accessibility of training, and the Internet is the unique environment for getting the access to educational materials, gives the potential for teaching and studies, uniting digital technologies and informational resources in the global informational educational surrounding [11]. The important aspect in the training of future bachelors of computer sciences is drawing the process of training to the future professional activity with the use of modern informational communication-technologies and the latest methods and means of ensuring of distant learning nearer. The big volumes of information for students are complicated for mastering in the full mode in the frames of classroomtime, and as consequence the materials should be available for students as while studying in the classroom and also during extracurricular time for their independent study. In the result of unification in the frames of the united curriculum and the educational process of full-time and distance form of studies, the studying process is optimized and the opportunities of participants of the educational process become balanced. Relying on the generic international experience of usage of the distance learning model of the Athabasca University [12], with the aim of support of self study of students and for ensuring of the possibility of the free and comfortable access of students to educational materials, the distance course has been developed. Lectures and practical materials, videos and other useful materials have been located on “The center of educational distant technologies” site of the university, built on the Moodle learning management system. The complex of enumerated elements creates the environment in which students receive the knowledge and transforms their social and professional experience, taking into account various kinds of cooperation. The developed educational and methodological complex is aimed at the formation of the flexible and integral model of training, which can be realized while full-time and distance learning. For the achieving of better results in the process of teaching with the help of distance course we have taken into account the requirements of labour market and specificity of the future professional activity of bachelors of computer sciences. The materials of the educational and methodological complex are structured on separate educational units (modules) with the outlined educational aim, the introduction, the theoretical part, educational tasks, progress tests and estimation of obtained knowledge. The components of the complex comprise a curriculum, materials for lectures and practical lessons, self-study materials, video series, accompanying every lecture, means of knowledge control in the form of tests, supporting litera-

ture, the electronic register of progress. For the tracking of course element processing, the academic electronic register is provided, which gives the opportunity to record students' progress, reflecting elements, contained in the electronic educational and methodological complex of the discipline and by default rated by the system. The elements, which are rated, include tasks for practical works and tests of theoretical knowledge. The control of practical skills and abilities of students is carried out according to the results of processing of lab works, where students design game surroundings or game characters. The control of theoretical knowledge of students is realized with the help of testing (see Fig. 3).

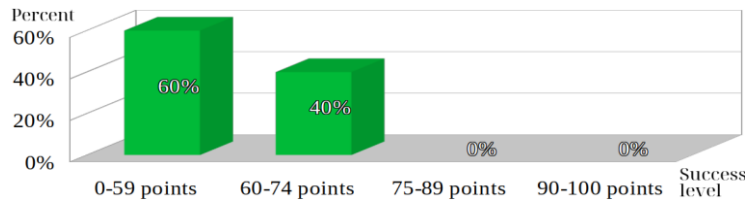


**Fig. 3.** The example of questions of control

As a means of feedback for realization of communications and qualitative educational support of students the forum has been used, which is the default element for all courses of the Moodle platform and provides all necessary tools for effective communication of students with tutors.

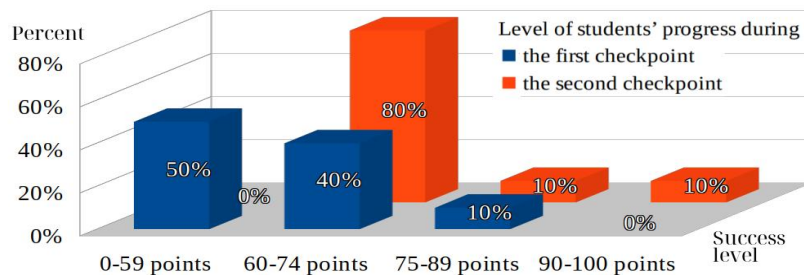
### 2.3 The results of the pedagogical experiment

Let us examine the results of experimental testing of effectiveness of introduction of methods of 3D modeling learning in the content of the “Computer graphics” discipline and the distance learning course for the understanding of the level of the graphical competence of students. As an experimental group of students third-year students of the “Computer sciences” speciality have been chosen. The pedagogical experiment has been performed in two stages: ascertaining and formative ones. With the aim of research problem revealing, the ascertaining experiment has been conducted, in the course of which the entrance control has been carried out for the study of the initial level of student knowledge on the technology of 3D modeling and the insufficient level of knowledge on 3D modeling technology has been revealed. The results of the entrance control are represented in the form of chart (see Fig.4).



**Fig. 4.** The results of the entrance control

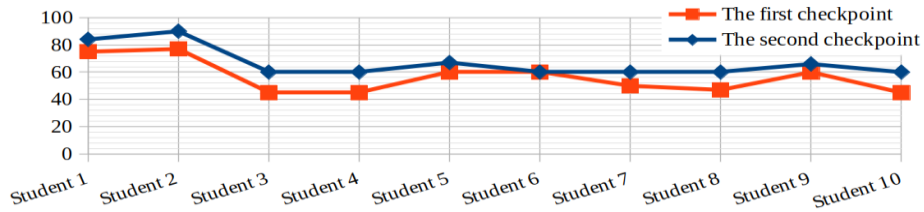
Thus, the research urgency has been defined and its problem has been formulated, which consists in the necessity of development of methods of 3D modeling teaching, aimed at the formation of spatial thinking, creative approach and aesthetic perception, which are components of the graphical competence of future bachelors of computer sciences. Relying on the conducted research, we have offered an idea that for the increase of the graphical competence level of students, namely the development of spatial thinking, creative approach and aesthetic perception as components of the graphical competence, the use of educational and methodological complex on the “Computer graphics” discipline is necessary. After the conduction of the ascertaining experiment for third-year students the study of educational material has been organized with the use of the developed educational and methodological complex and the distance learning course on the “Computer graphics” discipline. During the formative stage of the experiment the hypothesis was formulated: the introduction of methods of 3D modeling teaching in the content of the “Computer graphics” discipline and the distance learning course will assist the increase of the formation level of graphical competence components of future bachelors of computer sciences, namely the development of spatial thinking and skills of shaping, creative approach and aesthetic perception. For the checking of the effectiveness of introduction of 3D modeling teaching methods in the content of the “Computer graphics” discipline and the distance learning course, the first checkpoint was conducted during the progress control and the second checkpoint was performed at the end of studies of the discipline. Let us build the diagram of the dynamics of students’ progress level according to the data of the second checkpoint on the base of obtained data (see Fig. 5).



**Fig. 5.** The dynamics of levels of students’ progress points

After analyzing the diagram (see Fig. 4), we can make the conclusion that after conducting the experiment, the general level of progress and the level of formation of

graphical competence components both in the group in the whole and each student individually have increased (see Fig. 6).



**Fig. 6.** The comparison of results of the first and second checkpoints of students' knowledge

The comparison of individual progress indicators of students is liable to statistic processing, namely: the number of received points of experimental group during the first and second checkpoints of the experiment. The aim of the research consists in the determination, whether there are enough significant changes and whether it is possible to state that introduction of 3D modeling teaching methods in the content of the "Computer graphics" discipline and the distance learning course have led to the significant change of the level of graphical competence formation. For proving this, we calculate data with methods of mathematical statistics, using Student's t-measure. For the research the null hypothesis have been formulated (H0): the intensity of positive improvements of students' progress while the use of methods of 3D modeling teaching in the content of the "Computer graphics" discipline and the course of distance learning does not exceed the intensity of improvements of student knowledge level while studying offered educational materials without it. We will formulate the alternative hypothesis (H1) in the following way: the intensity of positive improvements of students' progress while using 3D modeling teaching methods in the content of the "Computer graphics" discipline and the distance learning course exceeds the intensity of improvements of students' progress without its usage. According to Student's t-measure H0 can be rejected in favour of H1, if according to the results of the statistical analysis the probability of the accidental appearance of the found difference does not exceed 0,05 or 5%. If the level of credibility is not achieved, then it is impossible to reject null hypothesis. Let us define the value of temp according to formula 1: [13]

$$t = \frac{(M_1 - M_2)}{\sqrt{\frac{S_1^2}{N_1} + \frac{S_2^2}{N_2}}} \quad (1)$$

where M1 and M2 – the average value of the first and second points; S1 and S2 – dispersion (standard deviation) for the first and second points respectively; N1 and N2 – the number of grades of the first and second points. Let us define the dispersion according to formula 2 [13]:

$$S^2 = \frac{\sum_{i=1}^n (X_i - \bar{X})^2}{N - 1} \quad (2)$$

where  $(x_1 - x_2)^2$  – the deviation square of separate values of signs from arithmetic mean;  $N$  – the number of signs. The dispersion is the indicator, which shows how the grade distribution curve is diffused regarding the value of its arithmetic value. The calculation of the dispersion of student training level is represented in *Table 1*.

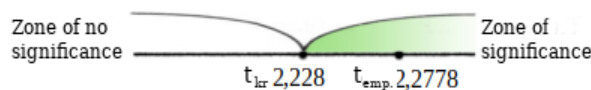
**Table 1.** The calculation of the dispersion of student training

Checkpoints	Points	Grades	Number of students	Arithmetic mean	Deviation from arithmetic value	Deviation squared	Product of the number of grades on deviation squared $n_i (x_1 - x_2)^2$	Dispersion $S^2 = \frac{\sum_{i=1}^n (X_1 - X_2)^2}{N - 1}$
				$x_2 = \frac{\sum_{i=1}^n (x)}{N}$	$x_1 - x_2$			
First	0-59	2	5	$\frac{29}{10} = 2,6$	-0,6	0,36	1,80	$\frac{4,4}{9} = 0,4889$
	60-74	3	4		0,4	0,16	0,64	
	75-89	4	1		1,4	1,96	1,96	
	90-100	5	0		2,4	5,76	0,00	
Second	0-59	2	0	$\frac{33}{10} = 3,3$	-1,3	1,69	0,00	$\frac{4,1}{9} = 0,4556$
	60-74	3	8		-0,3	0,09	0,72	
	75-89	4	1		0,7	0,49	0,49	
	90-100	5	1		1,7	2,89	2,89	

After the determination of dispersion, let us calculate  $t_{emp.}$  according to formula 1:

$$t_{emp} = \frac{(2,6-3,3)}{\sqrt{\frac{0,4889}{10} + \frac{0,4556}{10}}} = 2,2778 \quad (3)$$

After the determination of  $t_{emp.}$  we compare it with the table value. The table value of t-measure is smaller than calculated ( $t_{kr.(0,05)}(2,228) < t_{emp.}(2,2778)$ ). Let us build the axis of significance. (see Fig. 7).



**Fig. 7.** The axis of significance

In this case, the empiric value gets in the zone of significance. Since  $t_{kr} (0,05) < t_{emp}$ , this indicates that null hypothesis is rejected, the alternative hypothesis is accepted, namely: the intensity of positive improvements of student progress while using 3D modeling teaching methods in the content of the “Computer graphics discipline” and the distance learning course exceeds the intensity of improvements of stu-

dent progress without its usage for the level of credibility 0,05. Relying on the derived data of the experiment we can affirm that the usage of 3D modeling teaching methods in the content of the “Computer graphics” discipline and the distance learning course has positive influence on the development of spatial thinking and skills of shaping, creative approach and aesthetic perception, which are the components of the graphical competence of students; influences the development of intellectual potential of students, skills of work with 3D processors, improves knowledge required at the labour market; allows to increase the quality of training of future bachelors of computer sciences. The effectiveness of usage of 3D modeling teaching methods in the content of the “Computer graphics” discipline is aimed at the development of 3D models for the gameplay, virtual and augmented realities, in the educational process of training of future bachelors of computer sciences has found its confirmation according to the results of the experimental work.

### **3 Conclusion**

The usage of education materials in the process of professional training of future bachelors of computer sciences is aimed at the development of skills in 3D objects modeling (game characters, objects, surrounding) is the effective method of the increase of motivation and cognitive interest of students. The learning activity, aimed at the development of spatial thinking, creative approach and aesthetic perception allows to bring the training closer to the future professional activity, develop important competences in students: the ability to generate creative solutions, skills to approach critically to solution of set tasks, to base their own conceptions and ideas, to work in a team. The application of educational materials with the developed step-by-step algorithm of modeling of 3D objects in contemporary graphical processors on the example of 3D graphical Autodesk Maya processor makes the training more effective. Taking into account the actuality of the development of 3D models and surroundings not only in the industry of development of computer games, but also in the modeling of virtual and augmented reality, in the movie industry, in the educational process, the usage of 3D modeling teaching methods in the content of the “Computer graphics” discipline will assist the growth of the creative potential and the rise of the professional significant qualities of future bachelors of computer sciences. According to the results of the pedagogical experiment it has been revealed and proved with the help of statistical calculations, that the usage of 3D modeling teaching methods in the content of the “Computer graphics” discipline and the distance learning course in the process of professional training of bachelors of computer sciences is effective, in which the significance of research consists.

### **References**

1. Marenych, N.: Drawing as an Alternative Direction an the Visual Design of Video Games: Khudozhnia kultura. Aktualni problemy, 11, p. 156-157, (2015)



2. Osadcha, K. P., Chemerys, H. Yu.: Three-dimensional Modeling Tools in the Process of Formation of Graphic Competence of the Future Bachelor of Computer Science. *Information Technologies and Learning Tools*. 62(6), 72-74 (2017). doi: 10.33407/itlt.v62i6.1713
3. Osadcha, K. P., Chemerys, H. Yu.: Analysis of the Mention of the Concept “Graphic Competence” in the Preparation of the Future Bachelor of Computer Science”. *Ukrainian Journal of Educational Studies and Information Technology*. 5(3), 43 (2017). doi: 10.32919/uesit.2017.03.04
4. Aouad, G., Lee, A., Wu, S.: *Constructing the future: nD modelling*. Routledge, Abingdon (2006)
5. Schaefer, S., Warren, J.: Teaching computer game design and construction: *Computer-Aided Design*. 36 (14), 1501–1510 (2004). doi: 10.1016/j.cad.2003.10.006
6. Tori, R., Bernardes, J. L., Nakamura, R.: Teaching introductory computer graphics using java 3D, games and customized software: *ACM SIGGRAPH 2006 Educators Program on - SIGGRAPH '06*, (2006). doi:10.1145/1179295.1179308
7. Shultz, G.: Integrating Three-dimensional Graphics into Early CS Courses: *Journal of Computing Sciences in Colleges*. 21(3), 169-178 (2006).
8. Overmars, M. Teaching computer science through game design. *Computer*. 37(4), 81–83 (2004). doi:10.1109/mc.2004.1297314
9. Osadcha K. P., Chemerys H. Yu.: Formation of Computer Science Bachelor’s Graphic Competency While Studying The Prototification of Soft Interfaces. *Information Technologies and Learning Tools*. 67(5), 105 (2018). doi: 10.33407/itlt.v62i6.1713
10. Maya | Computer Animation & Modeling Software | Autodesk. <https://www.autodesk.ru/products/maya/overview>
11. Osadchiy, V. V., Osadcha, K. P.: The modern realities and tendencies of development of informational communicational technologies in the education. *The informational technologies and Learning Tools*. 48(4), 47-57 (2015). doi: 10.33407/itlt.v48i4.1252
12. Anderson, T., Elloumi, F.: *Theory and Practice of Online Learning Editors*. Athabasca University, Athabasca, Alberta (2008)
13. Obraztsov, P. I.: *Methodology and methods of psychological and pedagogical research (Lecture course)*. OGU, Orel (2002)

# Ontological Model of Representation of University Resources

Bogdan Buyak <sup>[0000-0003-1496-7573]</sup>, Ivan Tsidylo <sup>[0000-0002-0202-348X]</sup>,  
Serhiy Kozibroda <sup>[0000-0003-4218-0671]</sup> and Victor Repskyi <sup>[0000-0003-4297-5335]</sup>

Ternopil Volodymyr Hnatyuk National Pedagogical University, Ternopil, 2 Maxyma  
Kryvonosa str. Ternopil, Ukraine  
{buyak.bogdan, tsidylo, cerg.kozibroda, repskyi}@tnpu.edu.ua

**Abstract.** The article substantiates the expediency of using the ontological model of presentation of knowledge, which combines the properties and advantages of other models of presentation of knowledge and data in the process of construction, development, processing and application of ontologies. The analysis of application of systems of computer ontologies has been analyzed and the criteria of their selection are selected: software architecture and tools development; functional compatibility; intuitive interface. Determined to be the most optimal with regards to the training of future pedagogical engineers in the field of computer technology Protege OWL. The requirements, which are put in the process of designing an ontological model of representation of educational resources of the university, are singled out. The ontological model of representation of university resources used for unified description of knowledge bases from the point of view of competency requirements (knowledge, skills, skills) to student learning outcomes with the possibility of constructing repositories of electronic and educational resources was designed. The set of concepts and set of relations of computer ontology are presented. The method of filling the ontological base of knowledge of educational resources of the University is proposed. Experimentally, the efficiency of using the proposed ontological model for representing the University's learning resources in the process of training future engineers-educators in the field of computer technologies has been proved by the indicators: speed of construction under ontologies; number of defects.

**Keywords:** computer ontologies, knowledge representation, ontological model of university resources, designing.

## 1 Introduction

### 1.1 Setting of a problem

An analysis of the development of modern educational systems suggests that the amount of human knowledge accumulated today has a tendency to exponential growth and has long gone beyond the reach of one encyclopedia specialist, even for a particular part of one branch of science. The paradoxical consequence of such a spe-

cialization could be the slowdown in the development of science and technology in general, therefore, there is a need for the emergence of cognitive sciences and the corresponding knowledge engineering, the achievements of which enable the formalization of a certain field of knowledge through an appropriate information model that takes into account all objects, their attitude, proven statements about them, and so on. The answer to these needs is ontology simulation and computer ontology.

## **1.2 Analysis of recent research and publications**

According to most studies in this area, the problem of ontological modeling and the use of computer ontologies in higher education institutions is very relevant. However, most scholars focus on using computer ontologies, such as: N. Noy [15], B. A. Lapslyn [10], O. S. Narinyany [13], O. G. Yevseyev [22], V. V. Lyubchenko [11]. The process of developing and using computer ontologies is considered in the works of T. Gruber [6], T. Jeffrey [7], Y. Ding [3], S. Nirenburg [14], J. Zura [19]. A general review of the instruments of ontology engineering was undertaken only by O. M. Ovdey and H. Y. Proskudina [16]. The modeling of the ontology of the educational subject-based industry as a means of integrating knowledge was studied by O. H. Yevseyeva [22], V. V. Lyubchenko [11], O. E. Stryzhak [18], I. M. Tsidylo [21]. Modeling the categorical level of the language and ontological picture of the world – O. V. Palahin and M. G. Petrenko [17]. Ontological representation of the decision-making processes is Y. P. Chaplynsky [2]. Using the ontology of the subject area to eliminate ambiguities in the computer translation of technical texts – A. V. Morentsova [12] etc.

The works of the above mentioned authors contributed to the accumulation and systematization of knowledge for improving the practical training of students on the creation and use of computer ontology. However, they do not fully disclose the specialty of ontological modeling in the context of studying in institutions of higher education and the creation of ontology of a certain subject field of educational resources of these institutions.

## **1.3 Purpose**

The purpose of this study is to develop an ontological model for representing university resources in the process of training future engineering teachers in the field of computer technologies.

# **2 Results of the study**

## **2.1 Prerequisites for ontological modeling**

The modern stage in the development of science, education and production is characterized by the development and the use of information technologies based on knowledge, on the basis of computer technology, the relation of artificial intelligence

methods in the design of information systems. Currently, one of the prior directions of the development of information technologies is the transition to working with the semantics of information [1, p. 221]. In the process of working with semantic data, based on the facts obtained from the database, users can use logical rules to obtain new information (new statement). The possibilities and areas of relation of work with knowledge are expanding.

At the beginning of this century such processes are observed in the development of the theory associated with ontological modeling. Most research has already formed an understanding that the use of ontology libraries in the organization of information processes in the near future will be as widespread as the use of databases now. Therefore, ontological modeling is the answer to this need, because it allows to look at the process of designing, development, processing and use of the ontology of the predominant industry, and the development of an ontological model of presentation of university resources will allow: simulation of processes in order to optimize them; rapid receipt of logical conclusions based on a large amount of information in order to support decision-making; ensuring accessibility for users of large volumes of highly structured information; solving a number of technical problems, especially in the field of integration of information systems; automating the annotation of the learning resource and reducing the complexity of this process, to accumulate learning resources and further automate processing in the process of solving search and integration problems by means of computer ontology systems (COS); designing computer ontologies of personalized electronic didactic materials describing a plurality of university resources selected on the basis of the student profile, the relations between them, which specify the order of learning the study material included in the collection, and include in self-semantic rules for designing didactic materials based on ontology.

In addition, the training of engineering teachers in the profile "Professional Education. Computer Technologies" is becoming especially important in the current conditions of social and economic development of the country, which can be explained by the shortage of competent specialists of the new formation. However, the specifics of the training of future engineers and educators of the computer profile is that all disciplines of the curriculum can be traced to two interrelated areas of training related to the field of computer technology: pedagogical and engineering. The practice convinces that the prospective direction of professional training of future engineering teachers are ontologically managed information systems, the design of which is essential choice such as a formally-logical representation of knowledge, and sources of acquisition and renew of knowledge [4, p. 9].

In recent years, the number of tools for working with computer ontologies has sharply increased (more than 50 editing tools) [10, p. 101]. Therefore, in order to further design computer ontologies for representing the University learning resources in the context of training future engineering teachers in the field of computer technologies, it is advisable to use systemic computer ontologies (COS) [9, p. 61]. Their use is much to rapid and accelerate the process of designing computer ontologies on the basis of the proposed model.

In order to decide on the choice of a specific COS, having analyzed the skills of an engineer and educator and the use of computer ontologies in various fields, we distin-

guish three main criteria for choosing the COS [10, p. 178–179]: software architecture and tool development; interoperability covers; intuitive interface.

The choice of the most convenient COS depends first and foremost on the goals of the developer and the ontology developed, therefore, in the process of choosing COS for the training of future engineering teachers, Protégé, which meets all the necessary criteria for their successful practical activity, is the most appropriate means [8, p. 180].

It is based on a logical model that is designed to create definitions that are relevant to the informal description. Thus, the definition of complex concepts can be designed on the basis of simpler definitions. In addition, the logical model allows to find out which concepts correspond to the given definition and check that concepts and definitions in the ontology are mutually consistent [7, p. 233].

## **2.2 The justification of the ontological model of representing the university educational resources knowledge**

To implement a model of presentation of knowledge and data, it is expedient to use the ontological model of presentation of knowledge, which combines the properties and advantages of other models of representation of knowledge and data (graph model, tree-based model, relational model, semantic network, framing, logic model, etc.).

Solving the tasks of searching and integrating educational material in a person-made educational collection can be implemented in the ontological model as a result of the development and inclusion of the corresponding semantic rules in computer ontology [9, p. 99].

The ontological model of presentation of university resources (see Figure 1) used to unify the description of knowledge bases from the point of view of competency requirements (knowledge, skills) to the results of training students with the ability to build electronic repositories of the resources will look like:

$$O_{NR} = \langle C_{NR}, Inst_{NR}, R_{NR}, I_{NR} \rangle,$$

where:  $C_{NR}$  – the final set of concepts of subontology of university resources;  $Inst_{NR}$  – a set of instances of classes of subontology, annotated on the ontology of learning resources, which form a repository of learning resources;  $R_{NR}$  is the set of relations of subontology of learning resources.  $I_{NR}$  is the set of rules of interpretation,  $I_{NR} = \emptyset$ .

The learning resources described in the ontological model may belong simultaneously to several concepts of the ontology of the university educational resources and inherit the corresponding properties (attitudes). In the process of describing the contents of the teaching resources of future engineering teachers in the field of IT, the concepts of the ontology of the subject discipline of the discipline are used, which allows describing different learning resources in terms defined in the general domain.

The set of concepts of the ontological basis of university resource knowledge of learning resources is presented in Table 1, and the set of relations is given in Table 2. The defining areas and the domains of relations of values can be both defined concepts and their daughter concepts within the framework of ontology.

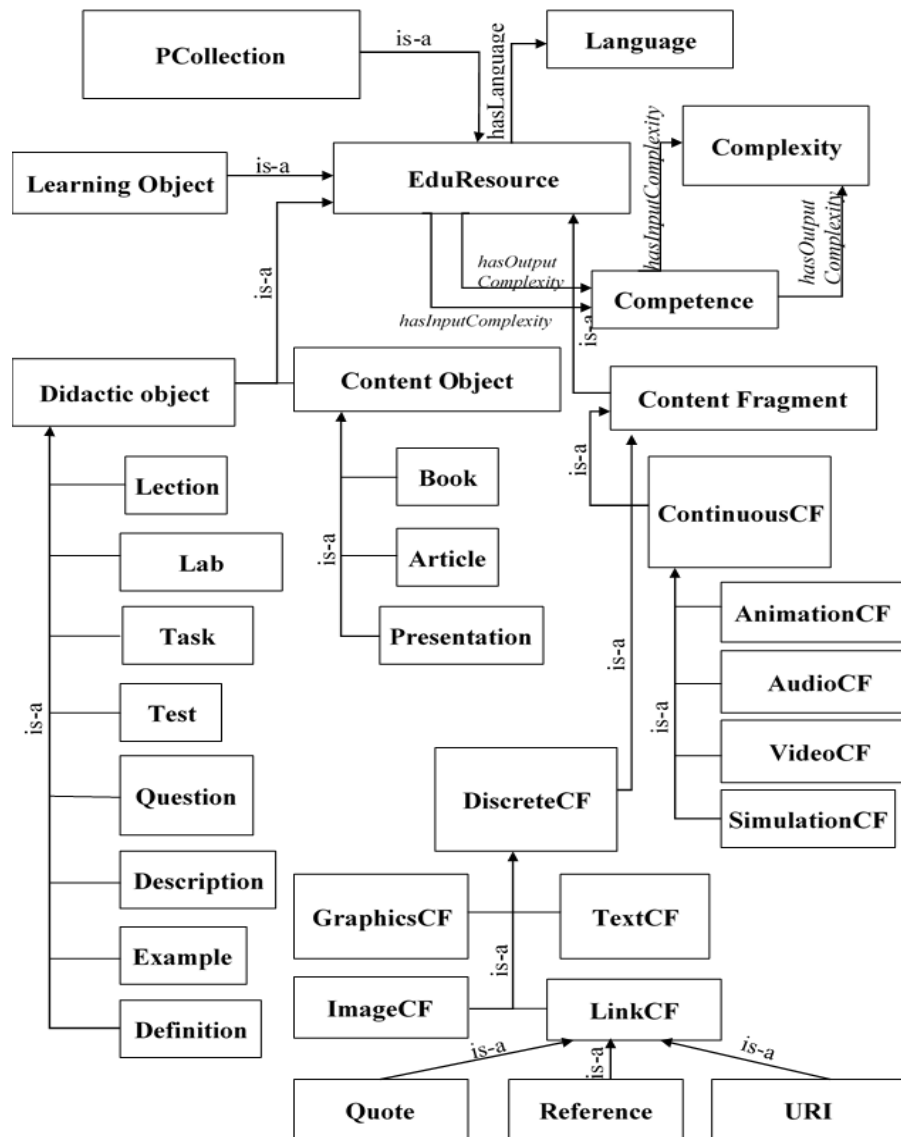


Fig. 1. Ontological model of educational resources of the university

Table 1. A set of concepts of computer ontology representing the learning resources of the university

Ontology concept	Parent Concept	Description of the concept
EduResource	Thing	University learning resources
PCollection	EduResource	Personalized learning materials
Learning Object	EduResource	Educational facilities currently available at an educational institution

Content Object	EduResource	Information resources of the University academic resources
Book	Content Object	List of available books from various subject areas
Article	Content Object	List of scientific articles from various subject areas
Presentation	Content Object	A variety of presentations from various subject areas
Content Fragment	EduResource	Information fragments of university resources
ContinuousCF	Content Fragment	Dynamic information fragments of university resources
DiscreteCF	Content Fragment	Static information fragments of university resources
GraphicsCF	DiscreteCF	Graphic elements of the University learning Resources
ImageCF	DiscreteCF	Image
TextCF	DiscreteCF	Text fragments of university learning resources
LinkCF	DiscreteCF	Links to other training resources
Quote	LinkCF	Quotes
Reference	LinkCF	Link to additional information
URI	LinkCF	Hyperlinks
AnimationCF	ContinuousCF	Animation elements of university learning resources
AudioCF	ContinuousCF	Audio elements of university learning resources
VideoCF	ContinuousCF	Video elements of university learning resources
SimulationCF	ContinuousCF	Simulation models and simulation learning resources of the university
Didactic object	EduResource	Didactic objects of learning resources of the university
Lection	Didactic object	Lectures on all disciplines
Lab	Didactic object	Laboratory work on all disciplines
Task	Didactic object	Tasks from all disciplines
Test	Didactic object	Tests on all disciplines
Question	Didactic object	Test questions from all disciplines
Description	Didactic object	Descriptions of all academic disciplines
Example	Didactic object	Examples of tasks
Definition	Didactic object	Definitions
Competence	Thing	Competences that are formed when studying one or another discipline
Complexity	Competence	Level of mastery of each competency
Language	Thing	Language of presentation of information

Table 2. The set of relations of the computer ontology of the representation of the university learning resources

<b>Peculiarity</b>	<b>Definition area</b>	<b>Competence area</b>	<b>Description</b>
hasInput-Competence	EduResource	Competence	The ratio that gives competence is needed to study this learning resource
hasOutput-Competence	EduResource	Competence	The ratio of competence, obtained as a result of the study of this learning resource
hasLanguage	EduResource	Language	Information presentation language
hasInput-Complexity	Competence	Complexity	Input level of mastering of competencies
hasOutput-Complexity	Competence	Complexity	Initial level of development of competencies
hasTitle	EduResource	string	The ratio that specifies the name of the learning resource
hasURI	EduResource	string	The ratio that specifies the storage location of the learning resource (for example, URI)
hasBibReference	EduResource	string	Bibliographic description

### 2.3 Methodology of filling the computer ontology of university learning resources

In addition to designing the ontological model of presentation of university learning resources, we conducted a research on the study and relation of computer ontologies by future engineering teachers in the field of computer technologies, which covers both cognitive knowledge of knowledge database and their engineering tools, as well as the structure of information (a list of its types and interconnections), necessary for a decision, means of receiving and preparing this information, the procedure for setting tasks for the design of computer ontologies, solving these problems and getting results. For the implementation of this ontological model, future engineering teachers need for each annotated learning resource to follow the methods of filling it by following the next steps:

- Identify the possibility of decomposition of the learning resource. For methodical instructions for individual laboratory works, presentations for lectures, other educational resources, the use of which is limited by separate modules of the work program on a academic discipline, annotation is conducted for the entire resource as a whole. For teaching manuals and other educational resources, the use of which is possible in several modules of the work program of the discipline, which have a large volume and complex structure, it is expedient to decompose such resources into separate elements (sections) and annotate them as a separate educational resource.



- Create a representation of the annotated learning resource as an instance of the class of computer ontology of the University academic resources, the corresponding type (Course, Lecture, Lab, Task, etc.).
- Describe the name of the learning resource and the language (s) of the information submission using the hasTitle and hasLanguage relations.
- Describe the bibliographic link for the annotated resource, in accordance with the references to bibliographic references using the hasBibReference relation.
- On the basis of the analysis of the learning resource and the first stage of the computer ontology of the discipline developed, identify the competencies gained in the process of learning about the other learning resource and the level of mastering them (high, necessary, critical or low). Describe them as instances of the Competence classes, linking the created instances to the relation with the corresponding instances of the description of the discipline and the relation isOutputCompetence in the computer ontology of the university learning resources. The level of possession of each competence as a result of studying the resource is determined by the relation hasOutputComplexity.

#### **2.4 Results of the experiment on the feasibility of using the proposed ontological model**

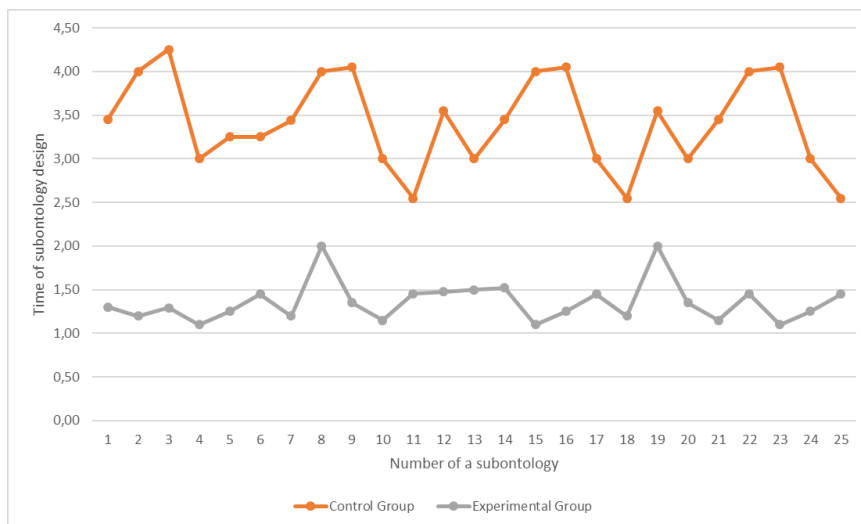
An experiment was conducted on the basis of the engineering faculty of the TNPU named after V. Hnatiuk in the process of realization of the designing method using the Prototype (COS), in which 50 future teachers in the field of computer technologies (25 experimental group and 25 control group). The assessment was carried out according to the following indicators: speed of designing subontologies; number of defects. For the students of the experimental group, the process of designing the computer ontology of university resources was carried out on the basis of the proposed ontological model and methodology based on the use of COS (in our case Protégé). The students of the control group carried out the design of the computer ontology of the University educational resources without using the model and using declarative programming languages.

The design of the computer ontology of the University learning resources, both in the control and experimental groups, was conducted modularly, that is, it was developed as a set of small modules (subontologies), which were later developed for the formation and use of one modular ontology. Like the learning process, the ontology design (ontology extraction, generation of ontologies or ontology acquisition) is an automatic or semi-automatic creation of ontologies, including obtaining the concepts of the corresponding domain and the relation between these concepts from the block of the natural language text and their coding with the ontology language for easy search. Therefore, each student (experimental and control group) built 1 subontology of educational resources for a particular discipline, which then were merged into the computer ontology of university resources. Therefore, as a result of the experiment, future engineering teachers in the field of computer technology built on one of the ontologies of the university academic resources for each of the groups.

In the process of designing subontologies, students use general concepts that are sufficiently defined in one ontology, while they are available from other ontologies, which avoids over-describing objects by reusing already-defined concepts. It will also make it possible to simplify semantic rules for the search of learning materials.

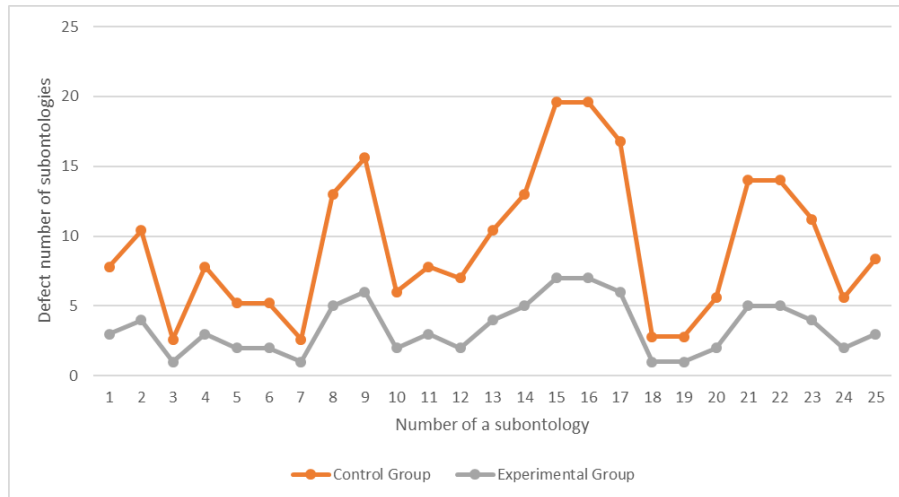
Comparison of the process of designing computer ontologies of university resources by students of experimental and control groups was carried out according to the following criteria:

- *The speed of design of subontologies.* Between the future engineering teachers of the control (students) and experimental groups (25 students), 25 disciplines were distributed with the corresponding learning resources, on the basis of which students had to build ontologies, and the time taken for the students of each of the groups for these 25 subontologies, which should be included in the ontology of the university educational resources. The results show (Figure 2) that students of experimental groups cope with this task faster 2.5–3 times on average.



**Fig. 2.** Comparison of the speed of designing subontologies by students of control and experimental groups

- *Number of defects.* The study of this indicator took place on the basis of the analysis of 25 constructed subontologies, which, in aggregate, give an ontology of university resources. According to the results of the analysis (Figure 3), it has been found that future engineering teachers in the field of computer technologies of experimental groups, in the training of which the proposed ontological model of the representation of university resources and the method based on the use of COS (in particular, selected during the Protégé analysis) has considerably fewer defects (almost 3 times) than that by the students of the control groups who have been designing the computer ontology of the University academic resources without using the model and by means of declarative programming languages.



**Fig. 3.** Comparison of the number of defects in the subontologies constructed by students of control and experimental groups.

### 3 Conclusions and perspectives for further research

- The ontological model of representation of the university learning resources is proposed, on the basis of which future engineering teachers in the field of computer technologies will be able to automate the annotation of the learning resource and reduce the complexity of this process, to organize training resources and further automate processing in the process of solving search problems and integration by means of COS, which meets the requirements of the model of presentation of knowledge. It is appropriate to use this model for a unified description from the point of view of the competence requirements (knowledge, skills, abilities) to the results of training students with the ability to build repositories of electronic educational resources.
- In the process of analyzing the COS and selecting the methodology for designing computer ontology of university resources, it has been discovered that Protégé, which meets all the necessary criteria for their successful completion, is the most optimal means for the training of future engineering teachers in the field of computer technology practical activity. A methodology for filling this ontology is proposed, which includes: determining the possibility of decomposition of the learning resource; creating the presence of annotated learning resource as an instance of the class of computer ontology; creating a description, the names of the learning resource and the languages of the presentation of information; creating a description of the bibliographic reference for the annotated resource; the ability to identify and describe the computing skills gained in the process of learning about a learning resource and its level of mastery.

- We have experimentally verified the effectiveness of the proposed ontological model of representation of the University learning resources in the context of the training of future engineering teachers in the field of computer technology on the following indicators: 1) the speed of designing subontologies; 2) the number of defects. On the basis of the analysis of the results, it should be noted that according to all the criteria the students of the experimental group, where the process of designing the computer ontology of the university resources was carried out on the basis of the proposed ontological model and methodology based on the use of COS (in this case Protégé) higher, than the students of the control groups who carried out the design with the help of declarative programming languages.
- The continuation of scientific research on the given problem is expedient in the investigation of the dependence of constructed hierarchies of concepts and concepts in the computer ontology of university resources and the development of ontologically managed information systems on their basis.

## References

1. Berners T. The Semantic Web. *Scientific American*. V. 120. № 3., 220–225 (2001).
2. Chaplinskyi Yu. P. Ontological representation of decision-making processes. *Informatization and management problems*. №2(26), 146-150 (2009)
3. Ding Y., Fensel D., Klein M. The role of ontologies in eCommerce. *Handbook of Ontologies*, (2004).
4. Dovhyi S. O., Velichko V. Y., Hloba L. S., Stryzhak O. E., etc. *Computer ontologies and their use in the educational process. Theory and Practice: Monograph*, Kyiv: The Gifted Child Institute, (2013).
5. Faure D., Nedellec C., Rouveiroi C. Acquisition of Semantic Knowledge using Machine learning methods: The System «ASIUM». *Laboratoire de Recherche en Informatique, Inference and Learning Group, Universite Paris, Sud*. 19. 56–64 (1998).
6. Gruber T. R. Toward principles for the design of ontologies used for knowledge sharing. *International Journal Human-Computer Studies*,. 43(5/6), 907–928 (1995).
7. Jeffrey T. Pollock *Semantic Web for dummies*. Wiley Publishing, Inc. Indianapolis: Wiley Publishing, Inc. (2009).
8. Kozibroda S.V. Software development tools for ontologies in the process of training computer engineering teachers. *Collection of scientific works of Kherson State University. Pedagogical sciences*. Vol. 74 (3). 175–180 (2016).
9. Kozibroda S.V. The use of system of computer ontologies as a means of forming the designing competences of future engineering teachers: diss. ... Candidate of Pedagogical Sciences: 13.00.10. TNPU after V. Hnatiuk. Ternopil, (2018).
10. Lapshin V.A. *Ontology in computer systems*. M.: Science World, (2010).
11. Lyubchenko V.V. Models of knowledge for subject areas of study courses. *Artificial Intelligence*. No. 458–462 (2008).
12. Morentsova A.V. Using the ontology of the subject area to eliminate ambiguities in the computer translation of technical texts. *Actual questions of modern science: III International scientific and practical conference: report theses*, Dnipro, January 30, 2018, p. 82–87 NBK (2018).

13. Narinany A. S. TEON-2: from thesaurus to ontology and vice versa. *Computational Linguistics and Intellectual Technologies: International Seminar-Dialogue'2002*. Science, Vol. 1, No. 307–313 (2002).
14. Nirenburg S., Raskin V. *Ontological Semantics*, Cambridge, MA, (2004).
15. Noy N. F., McGuinness D. L. *Ontology Development 101: A Guide to Creating Your First Ontology*. Stanford Knowledge Systems Laboratory, March 2001.: [http://www.ksl.stanford.edu/KSL\\_Abstracts/KSL-01-05.html/](http://www.ksl.stanford.edu/KSL_Abstracts/KSL-01-05.html/) дата звернення 24.08.2015.
16. Ovdey O. M., Proskudina H. Y. Review of tools of ontology engineering. *EB Magazine*. № 4. URL: <http://www.elbib.ru /index.phtml ?page=elbib/rus/journal /2004part4op> (2004) Date of appeal 23.03.2016.
17. Palahin O.V., Petrenko M. G. Model of the categorical level of the language and ontological map of the world. *Mathematical Machines and Systems*, No. 3, 91–104 (2006).
18. Stryzhak O. Y., Popova M.A., Lasyuk K.V. The method of creation of ontological interface in the environment of WEB-portal, *Radioelectronic and computer systems*, № 2, 78–84 (2014).
19. Sure Y., Erdmann M., Angele J., Staab S., Studer R., Wenke D. *Onto Edit: Collaborative Ontology Engineering for the Semantic Web*. *Proceedings of the First International Semantic Web Conference, Italia*. Vol. 2342 of LNCS, 221–235 (2002).
20. Tsidylo I. M., Kozibroda S.V. Systems of computer ontologies as a means to form future engineering teachers' design competences. *Information Technologies and Learning Tools*. Vol. 63, No 1, 251–265 (2018).
21. Tsidylo Ivan. Semantic ontology model of the content module of the course «Intelligent technologies of decision-making management». *Problemy Profesjologii*. Zielona Gora: Instytut Inzynierii Bezpieczenstwa I Nauk o Pracy Uniwersytet Zielonogorski, № 1. 131–139 (2014).
22. Yevseyeva O.G. Modeling of the educational subject area. *Artificial In-Tel .. No. 1*. 79–86 (2009).

# Mathematical Models and Methods of Supporting the Solution of the Geometry Tasks in Systems of Computer Mathematics for Educational Purposes

Michael Lvov<sup>[0000-0002-0876-9928]</sup>, Ludmila Shishko<sup>[0000-0001-9346-4338]</sup>,  
Irina Chernenko<sup>[0000-0003-2445-7366]</sup>, Evgen Kozlovsky<sup>[0000-0001-6630-083X]</sup>

Kherson State University, 27, University St., 73000 Kherson, Ukraine  
Lvov@ksu.ks.ua, Shishko@ksu.ks.ua, Chernenko@ksu.ks.ua,  
Evgen@ksu.ks.ua

**Abstract.** The article is devoted to the problem of supporting the course of solving tasks in geometry in systems of computer mathematics of educational purposes. In the work: - the mathematical model of the learning geometric task is defined; - the object-oriented approach to the description of mathematical models of geometric training modules is presented; - the methods of supporting step-by-step solving of learning geometric task are proposed; - the classification of elementary transformations in geometric subject modules is proposed; - the implementation of the concept of support for the solution of geometric tasks in the systems of computer mathematics of educational purposes is illustrated. Object-oriented analysis of the problem revealed three major classes of transformations of geometric objects. These are constructors, selectors, and converters (elementary geometric tasks).

**Keywords:** Systems of computer mathematics for educational purposes, learning geometric task, computer software, support of learning processes.

## 1 Introduction

The quality of mastering mathematical knowledge largely depends on the student's practical mathematical activity. This is the main form of educational activity in the study of disciplines based on mathematical models and methods, and is to solve learning mathematical tasks.

Review most domestic and foreign software for educational purposes in mathematics (GRAN, DG, Geometer's Sketchpad etc.) reveals the lecture part of the course is the maximally advanced one from both methodical and technical points of view [16, 17]. But practical functionality of these software tools is limited. Educational purpose practical mathematical activity is to construct the course of solving the learning mathematical task, but not to receive an answer [9].

The function of supporting the process of solving the learning mathematical task (*LMT*) is realized in the concept of systems of computer mathematics for educational purposes (SCMEP).

SCMEP is a programmed educational system for exact and natural educational disciplines that uses mathematical models and methods of subject areas based on technologies of symbolic transformations and methods of computer algebra.

The general theoretical and methodological foundations, the formulation of functional requirements for SCMEP and the development of a model of SCMEP as a system for supporting learning processes based on the analysis of actual forms and peculiarities of learning processes in precise disciplines are described in [3-5].

## 2 The outline of the problem

The implementation of the tasks of supporting the solution of *LMT* requires the definition of a mathematical model of *LMT* in the framework of a mathematical model of the training module and the construction of appropriate algorithms of computer algebra.

The SD curriculum is defined by the quadrants  $SD = \langle \Sigma, MM, ET, Task \rangle$ , where  $\Sigma$  - own signature of the training module,  $MM$  - list of models of the training module,  $ET$  - list of own elementary transformations of the training module,  $Task$  - a class of learning tasks, which defines the content of the  $SD$ .

The educational task  $P$  is determined by the list of mathematical models of the training module  $MM$ , the relation of the dependence  $\varphi$  between the models and their elements (the condition of the task) and the questions of the task  $Q$ :

$$P = \langle MM, \varphi, Q \rangle. \quad (1)$$

The scope of application of models of the module is mathematical discipline. Each of the mathematical disciplines has its own class of *LMT*. Of course, mathematical models of *LMT*, depending on the mathematical discipline, have their own peculiarities.

Mathematical models and methods for solving algebraic tasks in computer science mathematical systems are described in [6, 15]:

- functional requirements for activity environments supporting the solving of educational tasks in algebra are developed;
- definition of the concept of a training module in school algebra (signature, list of mathematical models, list of own elementary transformations);
- definition of the concept of *LMT* in algebra, algebraic object, types of *LMT* in algebra;
- the main specific tasks of supporting the step-by-step solution of the National Academy of Sciences are described.

The problem of this study can be formulated as a study of the specificity of the construction of mathematical models of learning geometric task, formal tasks supporting the process of solving the learning geometric task in the SCMEP and its implementation in the SCMEP.

### 3 Results

**Model of educational geometric task.** Under the learning geometric task (*LGT*), unlike school algebraic tasks, we understand the task that is formulated in terms of geometric objects, which is the subject of study and is supported by SCMEP. Learning geometric task as well as *LMT* in algebra are determined and solved by analytical methods. The peculiarity of *LGT* support is that the geometric object and the elementary transformations of the *LGT* can be interpreted geometrically, and therefore should be reflected in the corresponding graphical interpretation.

In order to implement the support of the solution of the learning geometric task, it is expedient to introduce the notion of a mathematical object. A mathematical object is: an algebraic object (*AO*) and a geometric object (*GO*).

Algebraic objects are numbers, variables, numerical and symbolic expressions, determinants, matrices, equality, inequalities, systems, sets of equalities or inequalities.

Primitive geometric objects (*PGO*) is the point of the plane and space, lines, curves 2-order curves in polar coordinates, surface 2nd order.

Primitive geometric object (*PGO*) is defined identifier (*ID*) and algebraic object for this syntax:  $PGO ::= \langle ID \rangle \langle AO \rangle$ .

Algebraic objects that determine the *PGO* are equations, inequalities, systems of equations or inequalities.

General definitions of *PGO*, except for variables, include alphabetic designations of *AO* coefficients - its general parameters. The general parameters of the *PGO* are the alphanumeric coefficients of the algebraic object that determines it.

**Mathematical models of geometric modules.** The structure of the geometric learning module is defined in the framework of the object design paradigm. Each *PGO* is an instance of the class.

For analytic geometry on a plane, these are the classes *Point*, *Line*, *Curve2*, *Circle*, *Ellipse*, *Parabola*, *Hyperbola*. The *Curve2* class defines the *PGO* curve of the 2nd order. The *PGO* Hierarchy of Inheritance allows to distinguish general and specific signatures, models, elementary transformations and standard learning tasks.

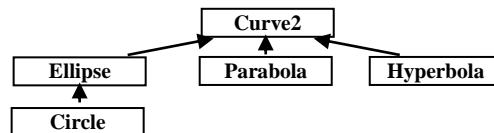


Fig. 1. Fragment of the tree of the classes of the module "Curves of the 2nd order"

Definition of the *PGO* class contains, in particular, the *AO*, which determine it.

```

Class PrimitiveGObject(
    CoordinateSpace Varset;           // (x, y);
    Variable ID;                       // l
    AlgObject F(x,y);
    ...
    Virtual CartesianSpace Draw();
    ...
);
  
```



Here is an example of a straight line class definition.

```

Class Line :: PrimitiveAnalGeomObject (
  Canonicalforms (
    Genequ  $a * x + b * y = c$ ,           // general equation
    Canequ  $y = k * x + b$ ,                 // canonical equation
    Segmequ  $x / a + y / b = 1$ ,           // the equation in the segments
  ); ...
);

```

Thus, the classes determine, in particular, various algebraic objects (general canonical forms), which, in turn, determine the geometric objects of the class.

Definition of the class of *PGO* allows you to list the various forms of algebraic representation of the *GO*, to indicate the parameters in letters, thereby defining the functions of access to the parameters, as well as their geometrical predictions. In addition, the class defines the specifications of the functions of algebraic transformations *PGO*.

A composite geometric object (*CGO*) is determined by the name, a set of *PGO* and the relationships that determine them. *CGO* are, in particular, punctures, directed segments, angles formed by rays, triangles formed by point-vertices, etc. The ray is determined through straight line, point and inequality. Directional segment is an ordered pair of points. The angle is a pair of beams with a common point. A triangle is a triple point.

From the point of view of the object-oriented programming paradigm [10], the *CGO* is defined by the aggregation classes and, possibly, the relationships between them and their parameters. Example:

```

Class Segment = (Point A, Point B);
Class SemiLine = (Line l, Point A)((A in l) & (x >= x_A)).

```

Parameters of a composite object are marked by qualified identifiers. For example, if *D* is a triangle, the coordinate *x* of its vertex *A* has the  $x_{D,A}$  identifier.

Classes of the *CGO* contain the definition of class member functions (transformations) that characterize the corresponding *CGO*. For example, in the Segment class, you should define the segment's characteristic as its length.

$$\text{Length}(A,B) = \text{Sqrt}(\text{Sqr}(x_B - x_A) + \text{Sqr}(y_B - y_A))$$

Apart from the classes of primitive and complex objects, the domain analytic geometry also defines elementary transformations - operations on objects. Example,

$$\text{LineAB}(A(x_A, y_A), B(x_B, y_B), l(\frac{y - y_A}{y_B - y_A} = \frac{x - x_A}{x_B - x_A}))$$

is a transformation that defines a direct plane passing through two points.

The result of an elementary transformation may be several objects. So, the intersection of a circle and a straight line determines either two points, or one point, or none.

The names of the *GO*, whose mathematical models are defined, are used in the *CGO* constructors as variables whose values are the corresponding mathematical models.

Each specific *LGT* can be formulated in terms of model, condition and question in the form (1):

*Given*: list of geometric objects; list of relations between them.  
*Find*: a list of objects (geometric, algebraic, logical).

The *LGT* model is a *GO* or a set of *GO* and *AO*. The task *ID* is the service word Task with the task number in parentheses. Example:

*Task 1. The distance between the points A (-2; 5) and M (x; y) is equal to three units of scale. Determine the coordinates of the point M if A and M are located on a straight line parallel to the abscissa.*

*Given:* Points A, M, with  $|AM| = 3, x_A = x_M$ .

*Find:* Point M.

Hence the formal definition *LGT*:  $Task(1) = (MM, \varphi, Q)$ , where  $MM = (A (-2; 5) \& M (x; y))$  – mathematical model,  $\varphi = (|AM| = 3) \& (y_A = y_M)$  - condition,  $Q = M$  - question (denoted as ?M).

To solve this task, it is necessary to determine the length of the segment:

$$|AB| = Length(A, B) = \sqrt{(x_B - x_A)^2 + (y_B - y_A)^2} .$$

Substituting an algebraic object instead of its name into a mathematical model of a task defines a complete algebraic model of the task:

$$\left\{ \begin{array}{l} \left\{ \begin{array}{l} x_A = -2 \\ y_A = 5 \end{array} \right. \\ \left\{ \begin{array}{l} x_M = x \\ y_M = y \end{array} \right. \\ \sqrt{(x_M - x_A)^2 + (y_M - y_A)^2} = 3 \\ y_A = y_M \end{array} \right.$$

The solution of the task can now be obtained by solving the systems of algebraic equations.

That is, the solution of *LGT* is carried out in terms of the simplest tasks, which are elementary transformations of analytic geometry, and algebraic transformations.

**Support for a step-by-step solution to *LGT*.** The introduced concept of the mathematical model of *LGT* allows us to investigate the problem of supporting the course of solving *LGT* in SCMEP.

*LMTs* are used to support the step-by-step solution in SCMEP using equivalence inference - an example based on the application of the rules of rewriting [1,2], is investigated in [6]. This type of inference naturally represents the course of the solution for *LMT* in algebra.

In order to support the course of solving *LGT*, it is proposed to use both an equivalence inference and a logical inference, since the mathematical models of *LGT* essentially use logical and algebraic means.

The course of the solution of *LGT* has two stages: the stage of compilation of the mathematical model and the stage of transformation of the model.

*At the first stage* the user must enter into the program the condition of the task. For *LGT*, the first stage plays a methodically important role. At this stage, support for user actions is to verify the mathematical model of the task [14]. Technologically, this is implemented in a separate window "Building mathematical model", which opens with the *Start Solution* command (Fig. 2). The *Verify* command has the function of verifying the correctness of the model.

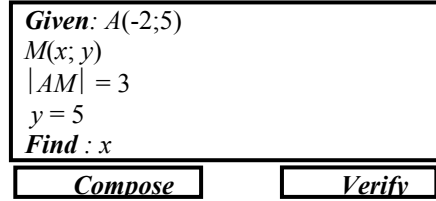


Fig. 2. Window "Building mathematical model" (schematic)

The implementation of this function requires:

- 1) the presence in the condition of the task of the correct model of this task and the answer (hidden from the user of the formal model (1));
- 2) implementation of the algorithm for comparing the model constructed by the user with the model or answer given in the condition of the task.

These requirements, in turn, require that the text of the task conditions all the symbols needed to formulate the mathematical model of the task.

The presence in the condition of tasks hidden from the user model of the task allows to automate the process of testing and debugging the text of the software module "TaskBook", as well as implement the function of composing the task model in software system (command *Compose*). Thus, if the user can not make a model of *LGT* independently, the system will perform this action itself.

*The second stage* - the stage of step-by-step solving is to form the course of the solution in the form of a sequence of transformations of the model of the task. The inference is a sequence of triples

$$((M_1, t_1, M_1'), (M_2, t_2, M_2'), \dots, (M_j, t_j, M_j'), \dots, (M_n, t_n, M_n')) \quad (2)$$

where  $M_j, M_j'$  – mathematical object,  $t_j$  - their transformation.

The problem we will discuss below is to define a complete, consistent and methodically correct list of transformations that support inference (2) and implemented as a structure of commands (references) that form the contents of the software module (*SM*) "Guide". This module, in turn, is used in the *SM* "Medium of Solving".

According to the definition of the *GO*, the *SM* "Guide" should contain both geometric and algebraic transformations, that is, the section "Transformation of algebraic objects", which contains equivalent algebraic transformations, the classification problem of which was investigated in [6,13], and the section "Transformation of geometric objects", which, in fact, contains the transformation of geometric objects.

**Elementary transformations of geometric objects.** Analyzing the problem from the point of view of the object-oriented programming paradigm, we distinguish transformation-constructors and transformation-selectors.

Transformation-constructor *PGO* builds *PGO* for its algebraic definition. Thus, the corresponding transformation has the specification  $t : AO \Rightarrow PGO$ .

In sequence (2), this transformation is represented by a triple  $(AO, t, PGO)$ . If the *AO* conversion argument is allocated during the solution, the *PGO* is entered into the solution as its last (new) row. In Fig. 3 shows the selected equation in the 5th line of the solution and the transformation-constructor of a straight line by its equation, the result of which is entered into the course of the solution as the 9th row.

<i>The course of the solution</i>	<i>Reference</i>
... 5. Convert the equation: $y = 2 \cdot x + 1$ ... 9. Construct a straight line $l$ by the equation (5): $l(y = 2 \cdot x + 1)$	<input checked="" type="checkbox"/> Construct a straight line for its equation <input type="checkbox"/> Highlight the equation of the line $F(x, y) \Leftrightarrow l(F(x, y))$

**Fig. 3.** A fragment of the course of the solution of the *LGT*

*Transformation-selector* allocates one or more objects that are included in the definition of the *GO*. Constructors and selectors, as a rule, can be interpreted as one reference that contains mutually inverse transformations (Fig. 4).

<i>Reference</i>	
<input checked="" type="checkbox"/>	Construct a circle according to its parameters
<input type="checkbox"/>	Highlight circle settings
$l((x - a)^2 + (y - b)^2 = r^2) \Leftrightarrow \begin{cases} a_l = a \\ b_l = b \\ r_l = r \end{cases}$	

**Fig. 4.** Reference – constructor and selector circle parameters

*Transformation-definition* introduces *AO* - definition of *GO*. For example, in the course of the solution of the *LGT*, we can include the definition of the tangent line to the function  $y = f(x)$  at point  $A$  (Fig. 5).

<i>Reference</i>
Equation of tangent line $L$ to function graph $G (y = f(x))$ at the point $A$ $L (y - y_A) = f'(x_A) (x - x_A)$

**Fig. 5.** Transformation-definition of a tangent line to the function graph

The transformation of the *CGO*, whose classes contain the definition of additional objects, are described by the *reference-selectors of additional objects*.

We separately note the necessity of the constructor and selectors of such algebraic objects as the equation, the system of equations, and the aggregate of equations. These transformations should be part of the Algebraic section of the *SM "Guide"*.

In addition to the transformations of the classes of *GO*, one must identify *elementary transformations* - operations on objects, so-called elementary tasks of analytic geometry. For example, a  $Point \times Point \Rightarrow Line$  transform, which defines a straight line passing through two points (Fig. 6).

<i>Reference</i>
Calculate a straight line equation that passes through two points $A, B \Rightarrow l\left(\frac{x - x_A}{x_B - x_A} = \frac{y - y_A}{y_B - y_A}\right)$

**Fig. 6.** Conversion – basic task of analytical geometry

Logical transformations - the transformations of the type  $GO \times GO \Rightarrow Bool$  return the value True, False. These transformations solve the tasks of the mutual position of the  $GO$  - the parallelism (the perpendicularity) of the straight lines, etc.

A special particular type of transformation is the isomorphic transformation of  $GO$ . They include: elementary transformations of the Cartesian plane or space, transformation of the transition to a polar coordinate system on a plane or transformation of the transition to spherical or cylindrical coordinate systems in space, transformation of the transition to vector algebra.

In the analytic geometry on the plane the following elementary transformations are used: parallel transfer, turning to the angle, stretching / compressing.

Both methodically and technically, these transformations should be realized in two forms: as an elementary transformation of a geometric object and as an elementary transformation of a plane. The transformation of the  $GO$  is to construct a new  $GO$  in the "old"  $xOy$  coordinate system. For example, a parallel transfer of a  $GO$  is defined by the transformation

$$l(F(x, y) = 0) \Rightarrow m(F(x + a, y + b) = 0).$$

The parallel transfer of the  $xOy$  plane is determined by the transformation

$$l(F(x, y) = 0) \Rightarrow l(F(x' + a, y' + b) = 0) \ \& \ x' = x - a, y' = y - b.$$

In the first form the result is a new object. Consequently, it is determined by the new  $ID$  and the new  $AO$ . The coordinate system remains "old". The second form changes the coordinate system and the  $AO$ .  $ID$  of geometric object is advisable to leave. The graphic illustration of this transformation form is to create a new Cartesian plane - the plane  $x'Oy'$  and the reflection of the  $GO$  in a new coordinate system.

The transformation of the transition to the polar coordinate system associated with the  $xOy$  system determines the transformation

$$l(F(x, y) = 0) \Rightarrow l(F(\rho \cdot \cos(\varphi), \rho \cdot \sin(\varphi)) = 0).$$

The inverse transform has the form

$$l(F(\rho, \varphi) = 0) \Rightarrow l(F(\sqrt{x^2 + y^2}, \arctg(y/x)) = 0).$$

The transformation of the transition to vector algebra. The solution of a  $LGT$  by a vector method consists in constructing a task model in the form of a formula in the signature of the Euclidean space and solving the task by algebraic transformations of this formula. Conversion of the transition to the vector method consists in the application the type of a reference (Fig. 7).

#### **Reference**

Consider the vector  
 $A, B \Rightarrow a = AB$

**Fig. 7.** Reference - Transformation of the transition to vector algebra

The further course of the solution of the  $LGT$  should be based on the list of transformations-definitions of vector geometric formulas and transformations-formulas in the signature of the Euclidean space. The list of definitions of vector geometric ob-

jects determines the completeness of the “Guide” from the section “Vector method in geometry”. Here is an example of this section of the *Guide*:

Vector method in geometry / Vector properties of geometric shapes

- Axiom of a directed section:  $AB = -BA$
- Axiom of the triangle ABC:  $AB + BC = AC$ , etc.

Transformation in the Euclidean Space

I. Axiom Euclidean vector space

II Theorems of geometry

- Definition of the scalar product:  $(a,b) = |a| \cdot |b| \cdot \cos(a,b)$ .
- The cosine theorem:  $|AB|^2 = |BC|^2 + |AC|^2 + 2 \cdot |BC| \cdot |AC| \cdot \cos(BC,AC)$ , etc.

A more detailed analysis can be found in [11]. The basis of the formation of sections of the “Guide” was chosen [12].

**Inference in geometric modules.** If the model of *LGT* is represented in the form of one formula, the course of its solution, in principle, can be obtained as a result of the equivalence inference (2). However, the submission of the terms in this form is not accepted. It is generally acceptable to formulate the condition in the form of a list of primitive conjuncts that specify the relationship between the PGO parameters of the condition of the task. Here is an example of the application of the mathematical methods and models for a geometric task.

*Task 2. Compose the equation of the tangent to the graph of the function  $y = x^2 + 1$  at the point  $A$  with abscissa  $x = 1$ .*

- Given:*
1. Graph  $F(y = x^2 + 1)$ .
  2. The point  $A(1, y_A)$ .

This condition must be supplemented by definitions by using the following elementary transformations-definitions:

3. Point  $A$  belongs to the graph  $F$ :  $y_A = x_A^2 + 1$ .

4. Equation of tangent line  $L$  to graph  $F$  in point  $A$ :  $L(y - y_A) = f'(x_A)(x - x_A)$ .

Rows 1-4 of the solution are a model of the task:

$$F(y = x^2 + 1) \& A(1, y_A) \& (y_A = x_A^2 + 1) \& L(y - y_A) = f'(x_A)(x - x_A).$$

Consequently, the step of inference (solving) depends on the data presented in the previous steps. To execute it, the user must specify the appropriate lines, find the transformation in the “Guide” and apply it.

**Realization.** The scientists of the Department of Informatics, Program Engineering and Economic Cybernetics of the Kherson State University under the guidance of the professor M. Lvov are engaged the implementation of the concept SCMEP.

Here are some SCMEP created by order and recommended by the Ministry of Education and Science of Ukraine (copyright certificates [7-8]):

- Program-methodical complex «TerM VII» of the support of a practical mathematical learning activity;
- Software tool "Library of Electronic Visual Aids Algebra 7-9 grade for secondary schools in Ukraine";
- Pedagogical software tool "Algebra, Grade 7";
- Software tool for educational purposes "Algebra, Grade 8";
- Integrated environment for the study of the course "Analytical geometry" for higher education institutions; and others.

Features of the support of the course of solving LMT in algebra and the principles of classification of elementary algebraic transformations for school algebra on the example of the program module (PM) "Guide" of TerM VII is considered in [6].

The concept of supporting the course of solving geometric tasks in SCMEP is partially implemented in TerM VII-IX, since the content of the course of school algebra presents educational tasks that contain elements of analytic geometry and are formulated in terms of geometric objects.

In TerM VII-IX there is a program module "Graphs", which is intended for the solution of LGT and LMT in algebra by graphic method. In it, it is possible to formulate an algorithm for solving a task in the form of a sequence of commands defined by the references of the PM "Guide" of the PM "Graphs". Its content is a structured list of elementary transformations of this mathematical model of the training module.

The PM "Guide" contains the following references:

*Section Formula-Graph*

1. Construct a point  $A(x; y)$  by its coordinates,
2. Construct a straight line  $ax + by + c = 0$ , etc.

*Section Graph-graph*

1. Conduct a straight line passing through two given points,
2. Find the point of intersection of two straight lines, etc.

*Section Graph -Formula*

1. Find reproduction of the coordinates of the constructed point,
2. Find the equation of a constructed straight line, etc.

*Section Converting Function Graphs*

1. Parallel movement in the direction of the abscissa axis  $x \Rightarrow x - a$ ,
2. Stretching (compression) from the abscissa axis  $x \Rightarrow kx$ , etc.

The use of the "Graphs" for solving a system of linear equations graphically and an algorithm for solving it using references of the "Guide" are illustrated in Fig. 8.

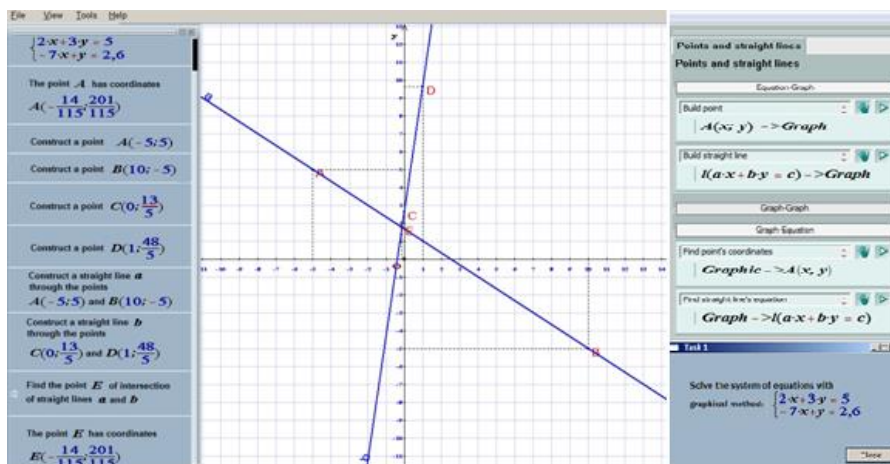


Fig. 7. Graphical method of solving the system of linear equations

We note that often the course of the solution of the *LGT* can be described as the language of algebra, as well as in the language of geometry ("find the intersection of the *GO*" or "solve the system of equations").

The proposed methodology was verified experimentally during the introduction into the educational process of "Integrated environment for the study of the course "Analytical geometry" in higher educational institutions of Ukraine. The experiment showed that the study of the course "Analytical geometry" provides a higher level of mathematical competence in the students of technical specialties [18, 19].

## 4 Conclusions

Practical mathematical activity of the student is the main form of educational activity in the study of mathematics. It consists in getting the course of the *LMT* solution.

In the work:

- the mathematical model of the *LGT* is defined within the framework of mathematical model of the training module and construction of the corresponding algorithms of computer algebra.

- the problem of forming a complete, non-contradictory and methodically correct list of transformations, by which one can carry out logical derivation, as a step-by-step solution to *LGT*, is solved.

- mathematical models of methods for supporting the solution of *LGT* in SCMEP are constructed.

Object-oriented analysis of the problem revealed the main classes of transformations of geometric objects (constructors, selectors and converters (elementary tasks)).

Obviously, in addition to algebra and geometry, this approach can be applied to such subject areas, where the content of educational tasks is the formal properties of interacting objects (physics, engineering, etc.).

## References

1. Podkolzin A.S. Komp'yuternoe modelirovanie logicheskikh processov. Tom 1. Arhitektura i jazyki reshatelja zadach. /A.Podkolzin. –M: Fizmatlit. –2008, 1024 s.
2. Lvov M.S. Metodi proektuvannya system komp'yuternoi pidtrimky matematichnoi osvity / M.S. Lvov, O.V. Spivakovsky // Matematychni modeli i suchasni informacijni tehnologii:zb. nauk. prac NAN Ukraini. Kiev. 1998, S. 101-111.
3. Lvov M. Osnovnie principy postroenija pedagogicheskikh programmih sredstv poddergki prakticheskikh zanjatij / Lvov M. // Upravljajushhie sistemy i mashiny. – 2006. – № 6. – S. 70-75.
4. Lvov M.S. Shkilna systema komp'yuternoji algebry TerM 7-9. Pryntsypy pobudovy ta osoblyvosti vykorystannia. / M.S. Lvov // Naukovyi chasopys NPU im. Drahomanova, seriia №2. Kompiuterno-orientovani systemy navchannia: zb.nauk. prats/ redkol. – K.: NPU im. Drahomanova. –#3(10) -2005. S. 160–168.
5. Lvov M., Shishko L., Chernenko I., Kozlovsky E. Systems of computer mathematics for educational purposes as the means of reception of procedural knowledge. CEUR Workshop Proceedings of the 12th International Conference on ICT in Education, Research and



- Industrial Applications. Integration, Knowledge and Harmonization Transfer, -K., Ukraine, June 21-24, -2016, S. 215-130.
6. Lvov M., Shishko L., Chernenko I., Kozlovsky E. Mathematical Models of Supporting the Solution of the Algebra Tasks in Systems of Computer Mathematics for Educational Purposes CEUR Workshop Proceedings of the 14th International Conference on ICT in Education, Research and Industrial Applications. Integration, Harmonization and Knowledge Transfer, - Kyiv, Ukraine, May 14-17, - 2018, P. 472-487
  7. A.s. 12440 MONU. Derzhavnyi departament intelektualnoi vlasnosti. Zbirka komputernykh prohram Prohramno-metodychnyi kompleks «TerM VII» pidtrymky praktychnoi navchalnoi matematychnoi diialnosti. Versiia 2.0, reliz 03.» osvithoi haluzi «Matematyka» dlia zahalnoosvitnikh navchalnykh zakladiv / Lvov M., Spivakovsky O., vs'ogo 9 osib; zaiavl. 10.03.2005. Biul. №7. – 2005.
  8. A.s. 32724 MONU. Derzhavnyi departament intelektualnoi vlasnosti. Komputerna prohrama «Intehrovane seredovische vivchennia kursu «Analitichna geometria» dlia vischih navchalnih zakladiv» / Peschanenko V., Lvov M., Spivakovsky O.; vs'ogo 8 osib; zaiavl. 06.04.10. Biul. №21. – 2010.
  9. Lvov M.S. Koncepcija prohramnoji systemy pidtrymky matematychnoji dijajlnosti./ M.S.Lvov // Komp'uterno-orijentovani systemy navchannja: Zb. nauk. praci/ K.:NPU im. M.P.Draghomanova.– Vyp. 7. – 2003. – S. 36–48.
  10. Pol A. Ob'ektno-orijentirovannoe programmirovanie na S / Pol A. – [2-e izd.].–Spb.; M.«Nevskiy dialekt»–izd-vo «BINOM», 1999.– 462 s.:il
  11. Bugrov Ya.S. Elementyi lineynoy algebryi i analiticheskoy geometri / Bugrov Ya.S. – M.: Nauka, 1988. – 222 s.
  12. Vyigodskiy M.Ya. Spravochnik po vyisshey matematike / Vyigodskiy M.Ya. - [8-e izd.]. – M.: «Nauka», 1966. – 872 s.: il.
  13. Lvov M.S. Term VII – shkilna systema kompiuterno alhebry. / M.S. Lvov // Kompiuter u shkoli ta simi. – 2004. – №7. – S. 27–30.
  14. Lvov M.S. Proektirovanie logicheskogo vyvoda kak poshagovogo reshenija zadach v matematicheskikh sistemah uchebnogo naznachenija / M. S. Lvov // Upravljajushhie systemy i mashiny. – 2008. – №1. – S.25–32.
  15. Lvov M.S., Shishko L.S., Chernenko I.E. Pro orhanizatsiiu kontroliu znan yak zvorotnoho zviazku v systemakh kompiuternoji matematyky navchalnogo pryznachennia / L.S. Shishko, I.E. Chernenko // Informatsiini tekhnolohii v osviti: Zb. nauk. pr. Vyp 16. - Kherson: Vyd. KhDU, 2013. – S. 29-42.
  16. Windham Wyatt K. Geometry Activities for Middle School Students with The Geometer's Sketchpad /K. Windham Wyatt, A. Lawrence, G. M. Foletta// Key Curriculum Press.– 1998.– P. 221.
  17. Lvov M. Software Module Representing a Geometry Tasks in Mathematical Systems of Educational Appointment / M. Lvov, D. Melnyk //CEUR Workshop Proceedings of the 14th International Conference on ICT in Education, Research and Industrial Applications. Integration, Harmonization and Knowledge Transfer, Volume II: Workshops Kyiv, Ukraine, May 14-17, –2018, – P. 73-82.
  18. Grigor'eva V.B. Komp'uterno-orijentovana metodika navchannya analitichnoyi geometriyi maybutnih programistiv: dis. kand. ... ped. nauk: 13.00.02 / Grigor'eva Valentina Borisivna. – Herson: HDU, 2017 – 270 s.
  19. Zaytseva T.: The Introduction of the Competence-based Approach in Educational Process of Training of Skippers. In: 12th International Conference on ICT in Education, Research and Industrial Applications: Integration, Harmonization and Knowledge Transfer, pp. 687-699. Kyiv, Ukraine, CEUR-WS, 1614, (2016).

# Attitude to the Digital Learning Environment in Ukrainian Universities

Olena Kuzminska<sup>1</sup>, Mariia Mazorchuk<sup>2</sup>, Nataliia Morze<sup>3</sup> and Oleg Kobylin<sup>2</sup>

<sup>1</sup> National University of Life and Environmental Sciences of Ukraine, Kyiv, Ukraine,  
o.kuzminska@nubip.edu.ua

<sup>2</sup> Kharkiv National University of RadioElectronics, Kharkiv, Ukraine,  
mazorchuk.mary@gmail.com, oleg.kobylin@nure.ua

<sup>3</sup> Boris Grinchenko Kyiv University, Kyiv, Ukraine,  
n.morze@kubg.edu.ua

**Abstract.** Needs of digital transformation requires specific flexibility from modern universities to ensure the society demands implementation through innovative teaching and IC-technologies. Modern universities create a digital learning environment to support studying activities. This research presents an experts' estimate of the current condition and perspectives of universities digital studying environments in Ukraine. We verified the theoretical model structure of the university digital studying environments by means of the empirical data factor analysis. We studied the components of the existing learning environment and enabling environment and compared them to the results of our previous research. We proved the digital learning environment theoretical model was correct. We proved that visions of students and teachers correspond to the key trends accelerating higher education technology adoption. We assume the digital learning environment development benefits overcoming significant challenges impeding higher education technology adoption.

**Keywords:** Digital Learning Environment, University, Survey, Factor Analysis, Education.

## 1 Introduction

The biggest digital transformation ever occurs right now. Unfortunate countries and enterprises those won't be able to adapt are done for. The Global Competitiveness Report 2018 claims that the promise of leveraging technology for economic leapfrogging remains largely unfulfilled [1, p.9]. A number of organizations require help to envision, structure, and sequence successful digital transformation efforts [2]. Strong institutions are a fundamental driver of both productivity and long-term growth. Their benefits extend well beyond economics, affecting people's well-being on a daily basis. Thus the question of the educational system improvement and transformation becomes more than urgent, as it's connected to preparing the competitive professionals at the observed tendency for digital technologies development [3].

Needs of digital transformation requires the flexibility of modern universities to ensure the implementation of society demands through innovative teaching and ICT-technologies. Leveraging these technologies requires not only the creation of the digital learning environment [4], but also changes in the educational process.

The tools to assess competitiveness, along with traditional concepts (such as ICT and physical infrastructure, macroeconomic stability, property rights, years of schooling) become crucially important concepts those go in a row with an entrepreneurial culture, multi-stakeholder collaboration, critical thinking, and social trust [1, p.7]. All these factors together influence the universities' competitiveness. Under a condition of the education system digital transformation enabling environment is meant to become the university digital learning environment (DLEs) with its following integration to the global digital environment.

Digitalization of the educational environments will improve the university competitiveness, that is important both for the students who decide on what university to choose and for the universities interested in attracting potential students, best teachers and researches, investments and grants.

This research aims to prove the theoretical model of the university digital environment structure and evaluate its relevance and perspectives for universities in Ukraine.

## **2 Theoretical Background**

Existing research studies in higher education proved that it's easier to engage students to learn with when ICT [5, 6]. The universities' key priority is improving their digital environment, that would support new academic policy, practices and technological landscape [7]. Accepting the digital learning environment in many ways depends on the educational trends and the most recent educational requirements. However, the technologies are also important for DLEs development. Digital learning environments include any set of digital tools and technology-based methods that can be applied to support learning and instruction [8]. We can claim that DLE is a next stage for the e-learning environment and the virtual learning environment [9], however, some researchers use these terms as synonyms. Universities and non-commerce organizations research on designing and developing digital learning environments and their effectivity. The digital learning environment Manifesto from the Edutainme aims to proclaim the principles of how to create digital learning environments, where the student will be a performer of his own learning, entitled to influence his own growth [10]. DUCAUSE (e.g., <https://library.educause.edu/topics/teaching-and-learning/next-generation-digital-learning-environment-ngdle>) helps elevate the impact of IT, thus the next generation digital learning environment (NGDLE) concept seeks for a balance between the openness of learning and the need for coherence in the environment and emphasizes personalization, collaboration, and accessibility/universal design – all essential to learning.

The university digital learning environment on different levels can be indicated by electronic scientific and educational resources, communication in the scientific and educational environment, management of scientific and educational activities, the

formation of new scientific and educational relations, competences. An international Project IRNet studied its participants' evaluation indicators of the digital environment in various universities and IC-competencies [11].

Herewith, the projects on improving the digital learning environments require both the teachers and students to participate in (<https://www.plymouth.ac.uk/news/connect/spring15/digital-learning-environment>). As soon as the students order educational service, and the teachers are responsible to provide these services at a great level, they become the categories to ask for an expert estimate of the higher education level and its components [12].

This assumption corresponds to the quality management principles of ISO quality management standards [13], namely QMP 1 – Customer focus and QMP 3 – Engagement of people.

### **3 Methodology of Research**

#### **3.1 General Design**

There exist various approaches to define the university digital environment components [14]. This paper considers the university digital learning environment as a cluster of components, which structure was modeled and proved by Ukrainian researcher L. Panchenko [15]. The author distinguishes such components as available equipment and Internet access (space-semantic component), students and teachers information competency (competency component), communication, and organization of the learning process (technological). As far as the received results validity depends on the research reproducibility [16] we conduct the repeated expertise on the mentioned components, taking into account the changes occurred lately. The MC Horizon Report claims there exist consistent educational trends, new trends appear all the time, and some trends and issues reappear over time [3, pp. 4-5]. For example, the need in growing focus on measuring learning and redesigning learning space is still immediate. The requirements to the open educational resources (OER) and their proliferation change the requirements of cross-institution & cross-sector collaboration; rise of new trend. The new forms of interdisciplinary studies step forward. The modern universities react to the changing requirements. The technology development (open source software for scientific communication), wider access to the external resources (scientific platforms and databases), rising demands and educational requirements from the students and such objectives as academic mobility and scientific cooperation, including the international cooperation, lead to specifying the components of the suggested theoretical model. The common tendencies rely on the transformation of the educational and information environments into the digital one, information competency into the digital competency, communication in education, that is not limited to the university environment. Scientific researches in the field of advancing cultures of innovation, advancing digital equity plays an even more important part.

To understand the attitude of the Ukrainian teachers and students to the universities' digital learning environment we put together a set of the theoretical model components.

- *Space-semantic*: Available Internet access, good traffic, equipped studying rooms, hostings, and educational platforms, particularly LMS, e-library, institutional repository, e-conference system, access to the wiki-portal and corporate accounts, etc.

- *Technological*: educational resources integration (e-library, OJS edition, repositories, etc.), content development and delivery, access to the external educational sources, scientific databases, well-organized consultation and expert estimation system, creating the educational program according to the educational requests from the students, monitoring and tweaking the processes of using the environments for individual work, applying e-learning, project-based learning, blended learning, collaborative learning, combined formal and informal learning, shared research work, etc.

- *Communicative*: scientific and educational communication through email, corporate resources (websites of departments professors, and conferences, corporate clouds, e-libraries, etc.), external resources (social networks and services, forums and communities, e-conferences, etc.), consulting, experts' evaluations.

- *Competency-based*: the level of digital competencies through self-evaluation, peer-to-peer evaluation, e-portfolio, achievements recognition, motivation and training those who can improve the level of digital competency.

The authors of the article claim, that the defined challenges impeding higher education technology adoption can be solved by building and applying the digital learning environment. Thus, the digital learning environment contributes authentic learning experiences, improving digital literacy, adapting organizational designs to the future of work, advancing digital equity.

Research Tasks:

1. Provide a theoretical model of the university digital educational environment expertise and to build a statistical factor model of the university digital environment.
2. Analyze if the digital educational environment of the Ukrainian universities corresponds to the digital and educational trends.

Assumptions:

1. The digital environment model planned to build using the statistical methods and models corresponds to the suggested theoretical model.
2. The universities digital environments development reacts to modern technologies and educational trends. That is also one of the tools to overcome the challenges impeding higher education technology adoption and to improve on the higher education quality.

### 3.2 Instruments and Participants

We performed the expert estimate of the university digital environment by means of online inquiry and in-depth interview (in case if we needed elaborateness). We distributed the survey (<https://forms.gle/7h56MAxf5JAGQ9Eh6>) with mailout and specific-purpose contacts with the educational institutions.

To perform the expertise of the university digital environment for our research we invited masters and teachers (professors) from the best universities of Ukraine (where 70% are research universities). Mostly, our respondents' occupations lie in the field of Mathematics, Computer programming, IT (28%), Education (22%), those are considered to be the top-priorities in Ukraine. The age, gender, and positions of the sampled population represent the real situation in the educational institution: there are more students and teachers, the age of students and teachers corresponds to the age-grade in general, there are more women among the respondents that is natural gender correlation for the educational institutions in Ukraine. The research didn't take into account the connections between the features, fields of occupation and the educational institutions, that is why it can't be considered from that point of view. Mostly, our respondents had assessed to the computers and to the international scientific databases. The non-sampling error on the studied features didn't exceed 9% (123 person). The full list of the estimated features that reflect personal data of respondents is provided in Table 1. Every feature has calculated beforehand descriptive statistics and constructed frequency distributions.

**Table 1.** The main characteristics of the respondents

Feature	Category of a feature	Meaning	Percent / Descriptive statistics
Gender	1	Male	26,00%
	2	Female	74,00%
Status	1	Student (Magister)	59,00%
	2	Teacher (Professor)	41,00%
The University	1	National University of Life and Environmental	40,00%
	2	Boris Grinchenko Kyiv University	20,00%
	3	National Aerospace University "Khal"	7%
	4	Taras Shevchenko National University of Kyiv	6,00%
	5	National Pedagogical Dragomanov University	11%
	6	National Technical University «Kharkiv Polytechnic	5,00%
	7	Lviv Polytechnic National University	6%
	8	Others	5,00%
Availability of mobile and technical devices	1	Always	67,00%
	2	Not always	32%
	3	The availability is restricted, I can hardly use devices	1,00%
Access to international science and technology databases	1	Always	18,00%
	2	Not always	62,00%
	3	The availability is restricted as the full access requires money	20,00%
Age		Age of respondents	Mean=31,01
			Median=23,5
			Mode=22,0

Knowing the level of the respondents' digital competency is essential to conduct an estimation of the digital educational environment. Mostly, our respondents evaluated their levels as middle and advanced proficiency [17]. In addition to the questions on the research topic, they had to answer if they had registered profiles in the scientific databases such as Web of Science (WOS) or Scopus, personal profiles in the ResearchGate social network, publications in the online journals or experience in informal education. We added these questions to understand if our experts are ready to

overcome such challenges as advancing digital equity and participating cross-institution & cross-sector collaboration. The answers we received were mostly positive. Those respondents who had no profiles in scientific databases or experience with online conferences and courses claimed they wished to have that experience and believe in its importance. Herewith, we observe an obvious statistical connection between the estimated level of the respondents' digital competencies and the answers to the mentioned questions. Table 2 contains answers of our respondents.

**Table 2.** Distribution of answers to questions about the level of competencies gained by respondents

Feature	Category of a feature	Meaning	Percent / Descriptive statistics
Participation in online conferences and webinar	1	I participated in a conference/webinar	55,00%
	2	I organized a conference/webinar	8,00%
	3	No. I intend to take part in a conference/webinar	21,00%
	4	No. I intend to organize a conference/webinar	4,00%
	5	I don't think it's necessary	12,00%
Publications in online-journals	1	Yes, I have	46,00%
	2	Yes I have, and I am also an editor, reviewer, etc	3,00%
	3	No, I don't, but I intend to make publications	38,00%
	4	No, I don't. I don't think it's necessary	13,00%
Profile in the ReserchGate social network	1	Yes, I am an active member	6,00%
	2	I have a profile, but I hardly use it	18,00%
	3	I don't have a profile, though I plan to create it	42,00%
	4	I don't have a profile, I don't think it's useful	34,00%
Profile in the WOS or Scopus databases	1	Yes, I have publications in these databases	19,00%
	2	I have a profile, but I don't have my own	23,00%
	3	I don't have any publications yet, but I have them in my plans	28,00%
	4	I don't have any publications, I don't think I need them	30,00%
Experience in informal studying	1	Yes, I am. I am an active listener of MOOCs	44,00%
	2	Yes, I am an author for MOOCs	5,00%
	3	No, I don't, but I have it in my plans	38,00%
	4	No, I don't. I don't think I need it	13,00%
Own level of the digital competency	1	0	3,00%
	2	1	4,00%
	3	2	27,00%
	4	3	51,00%
	5	4	15,00%

Thus, we can claim that aggregated values on the selection that we received correspond to the goals of our research. The level of competencies allows teachers and students (masters) who participated in our survey to be the experts.

The questionnaire contained two question pools considering the students and teachers attitude to the educational information environment of the university, the need for the environment development, and the questions considering the respondents' personal data and competency level.

The questions consider the university digital learning environment, which our theoretical model consider as 4 interacting components. The questionnaire has 4 sections

that correspond to 4 components: space-semantic, technological, communicative, and competency-based. Each section contains from 6 to 14 assertions. The respondents estimated if the mentioned components are available in their educational environments (1st group of questions) from 1 to 4 points (where 1 stand for the poor level of availability, 2 is for middle level of availability, 3 is the enough level and 4 stands for the expert level). The respondents estimated the importance and availability of improvement for the mentioned components (2nd group of questions) from 1 to 3 points (where 1 stands for low, 2 for the middle, 3 for high). For example, respondents have a request “Please rate the proposed components of the environment on a scale of 0-4” and several assertions such as: “Your university has access to broadband internet”, “You can access the internet in every lecture hall in your university”, etc.

### **3.3 The Methods and Models of Data Processing**

The choice of methods is determined by the purpose of the study. We needed to process a rather large array of statistical data and identify the main patterns. During the research, we applied the methods of descriptive statistics to find the frequency distribution and to define the central tendency rates. To prove the hypothesis we stuck to the statistical inferences methods and models. The method selection based either on the type of the scale used for estimation or on the datatype of the features we had to estimate. To analyze connections between the features we applied the methods of correlation and regression analysis. The calculations were conducted based on the sampled population, and the statistical results were verified at the 95% integrity level.

During the study, it was necessary to consider a large number of variables that describe the digital environment of the universities. However, it is difficult to identify patterns in a large array of features without data reduction. With factor analysis, we managed the empirical data received in the survey, performed the data reduction and shortened the number of features, in order to study the received model structure of the educational environment of the university. The factor analysis was performed in accordance with the basic stages: defining the preliminary features to be reduce, building a correlation matrix to find the connection between the elements, defining the methods of data reduction, choice and explanation of the main factors, calculations and interpretation of the results we received.

The analysis is not reliable if the basic requirements for the reliability of data and measurement scales are not taken into account. To estimate the reliability of suggested scales we used the intraclass correlation coefficients so that later we could calculate the ‘intra respondents’ estimates of reliability. To find out the internal consistency in the survey we found the Cronbach’s alpha and Spearman-Brown coefficient. The calculations were done mostly using SPSS software [18, 19].



## **4 Results of Research**

### **4.1 The Results of a Survey Reliability Estimate**

At the first stage of our research, we estimated the reliability of the respondents' answers and analyzed what different kind of analysis we can apply.

For the questions on the university digital learning environment, we performed separate analysis considering the availability of required components in their learning environments. Just the same we performed a separate analysis on the components' level of development and on ways to improve some component.

For both these questions the Cronbach's alpha and Spearman-Brown coefficients were quite good: Cronbach's alpha — 0.981 and 0.978; Spearman-Brown — 0.902 and 0.861. According to the correlation matrix we built, the correlation of some points of the survey was equal to 0.78-0.79. That means, that the features used to build the theoretical model shared common agents that can be combined. The received numbers are reliable, that we proved with the Fisher coefficient equal to  $p < 0.05$ .

### **4.2 Using Factor Analysis to Model the Informational and Educational Environment of the University**

At the next stage, we leveraged the factor analysis based on the method of main components [20, 21]. This method allows reducing the number of features that describe the university digital learning environment in accordance with a theoretical model build before. The factor analysis validity was proved both when evaluating the respondent's answers and based on query obtained from the Kaiser-Meyer-Olkin measure of sampling adequacy and Bartlett's test of sphericity [18].

Besides that, we calculated these criteria for the questions that consider the availability of the required components (group 1) and the importance of components development and improvement (group 2).

The Kaiser-Meyer-Olkin measure of sampling adequacy for the questions in the 1st group is equal to 0.9. High criteria value (from 0.5 to 1) proves that the factor analysis was viable in this case. Low values (less than 0.5) prove that the factor analysis is not beneficial for the specific situation. Thus, for our case, we can use the factorial analysis. The Bartlett's value of sphericity is equal to 9132.97 at  $df=2080$ , that is large for the  $p < 0.001$  level, and also proves that factorial analysis is beneficial for this specific case.

The value of Kaiser-Meyer-Olkin criteria for the questions of the 2nd group is equal to 0.802. The Bartlett's value of sphericity is equal to 8599.164 at  $df=2080$ , that is large for the  $p < 0.001$  level. This group is also appropriate to use the factor analysis.

At the next stage, we defined a number of factors. There are several methods to do so, such as to calculate the proper values, or to use a scree plot and Kaiser's criterion [18]. However, for this research, we considered the worked through the information of the problem structure that we received from the previous stages of the research and confirmed that structure with statistics (namely, with the sampling variance percent-

age). As a rule, the researchers recommend selecting the number of factors that samples at least 60% of the variance.

Based on the environment expertise results and theoretical analysis we received before, we selected the 4 factor model of the university digital learning environment that has such components as special equipment and Internet access, educational websites and portals, teachers' and students' digital competencies and communication, and a well-organized process of education.

According to the sampling variance percentage criteria, we can claim that 4 factors for the 1st group of questions sample over 60% of the variance (63.51%), and almost 60% for the 2nd group 58.27% (see tables 3 and 4). In these tables, you can also find the sampling variance percentage after we turned the matrix of main components. The numbers in the 'variance %' column proves that the components we've built are quite informative.

We can see that in the 1st group of questions 3 groups of components sample the part of variance (20.85%, 17.07% , 16.2%), while for the 2nd group the distribution is more smooth between 2 first components (16.76%, 16.53%) and 2 following components (13.82% , 11.16%). Thus, some factors in the information environment correlate more, and so explain the percentage of the factors variation, while the importance of development is the same for all components. For the factor rotation, we utilized a common rotation method "varimax" that minimizes the number of variables with high values and increases the possibility for factor interpretation.

**Table 3.** The percentage of sampling variance for the 1st group of questions that consider the availability of required components in the learning environments

Component	Load sum of squares extraction			Load sum of squares after rotation		
	Total	Whole % variance	Summary %	Total	Whole % variance	Summary %
1	30.156	46.394	46.394	13.554	20.852	20.852
2	5.399	8.306	54.7	11.097	17.072	37.924
3	3.248	4.997	59.697	10.529	16.199	54.122
4	2.48	3.816	63.513	6.104	9.391	63.513

**Table 4.** The percentage of sampled variance for the 2nd group of questions that consider the importance of the development of components and the ways of how can be improved

Component	Load sum of squares extraction			Load sum of squares after rotation		
	Total	Whole % variance	Summary %	Total	Whole % variance	Summary %
1	28.019	43.106	43.106	10.894	16.76	16.76
2	4.35	6.692	49.798	10.741	16.525	33.285
3	3.022	4.649	54.447	8.985	13.824	47.109
4	2.482	3.818	58.265	7.251	11.156	58.265

At the following stage, we received rotated solutions of the factor matrix, that allowed us to combine the features according to the results of the factor values of the 4 separate components. In tables 5 and 6 you can see the fragments of the factor loadings, as they were quite a lot of features for every group. We should also mention that the features for the groups 1 and 2 were grouped with different approaches, so the main components were interpreted separately.

**Table 5.** A part of the factor loads matrix of the learning environment model those correspond to the availability of components in their learning environments (Group 1)

Features	Components			
	1	2	3	4
Teachers' usage of Internet social services	0.825	0.066	0.211	0.107
Participation in scientific communities in the university	0.806	0.024	0.209	0.283
Students' participation in scientific social networks	0.806	0.143	0.175	0.196
Teachers' participation in scientific social networks	0.801	0.1	0.26	0.116
Teachers' participation in the professional Internet-communities	0.778	0.158	0.311	0.162
Students' participation in the professional Internet-communities	0.738	0.298	0.357	0.075
Searching and inviting the experts (scientific consultants, mentors, etc.)	0.734	0.226	0.33	0.264
Consultations and reviewing, in particular at the webinars and in Internet-communication	0.696	0.305	0.369	0.098
Students' publications in online journals	0.687	0.116	0.377	0.146
Students' participation in online conferences	0.684	0.223	0.385	-0.108
Students' usage of Internet social services	0.681	0.069	0.161	0.004
Teachers' publications in online journals	0.677	0.111	0.381	0.075
Teachers' participation in online conferences	0.675	0.156	0.421	-0.021
Teachers' usage of emails, in particular, the corporate accounts	0.602	0.131	0.182	0.25
Students' usage of emails, in particular, the corporate accounts	0.594	0.174	0.12	0.161
Systematic publications of records about the completed plans, scientific activities, cooperations, etc.	0.537	0.367	0.2	0.366

**Table 6.** A part of a matrix of the factor loads of the learning environment model those correspond to the availability of components in their learning environments (Group 2)

Features	Components			
	1	2	3	4
The level of students' digital competency	0.832	0.267	0.195	0.079
Experience utilizing digital competencies in scientific work	0.814	0.26	0.286	0.097

Training courses on boosting digital competencies for teachers	0.8	0.317	0.183	-0.041
Presentation of the teachers' achievements (e-portfolio)	0.795	0.163	0.18	0.292
Self-estimate of the digital competence	0.793	0.18	0.248	0.196
The level of teachers' digital competency	0.789	0.074	0.2	0.188
The research results approbation	0.788	0.307	0.196	0.126
Publishing the results of scientific researches	0.781	0.229	0.209	0.249
Training courses on boosting digital competencies for students	0.769	0.31	0.226	0.132
Recognition of results in the scientific community: personal profiles in scientometric databases, certificates, patents, etc.	0.753	0.12	0.157	0.261
Support from the IT-departments	0.728	0.289	0.291	0.115
Presentation of the students' achievements (e-portfolio)	0.718	0.455	0.207	-0.017
Distant learning	0.676	0.128	0.213	0.278

We defined the variables that have high load values on the same factor. Then, we analyzed this factor considering the mentioned variables. We also interpreted the variables' graphics, those coordinates the factor loads (Figure 1.).

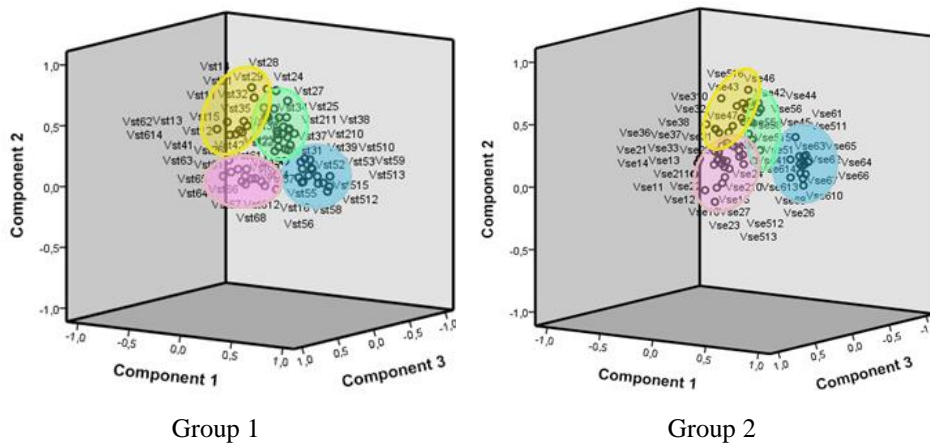


Fig. 1. The graph of the contribution of characteristic values to the main components: groups 1, 2 (Source: Own work)

As a result, we received a confirmation for the university digital learning environment theoretical model we built, as with small deviations we managed to combine and group features into four components.

Here we suggest a data interpretation of receive four-factor model for the 1st and 2nd groups. We found a common factor that corresponds to the competency-based

component that we defined both 1st and 2nd groups. To the 2nd group got an additional element “distant learning” (see Table 6), that we can explain as the readiness of teachers and students for self-education and online study mode. Today, (group 1) the face-to-face courses are used mostly for improving the level of competencies in the universities. The other factors for the 1st and 2nd groups differ.

The second factor (group 1) has high factor loads connected by technological and space-semantic component. The respondents in the available environment do not distinguish the space-semantic component, yet consider the technological component as an optimal combination of infrastructure, resources topology and educational technologies. The third factor (group 1) corresponds to the communicative component that has features of scientific communication by means of digital technologies (Table 5). This component also included the variables connected to the returns automation and systematic academic and scientific journals declaration, and students and teachers mobility (technological component). Thus we can make an assumption on the availability of communication management from the university. The fourth factor (group 1) we would explain as collaborative and research component, as it contains the variables of monitoring and correcting the process of environment usage for self-guided work, formatting the messages of education according to the student’s requests, learning in cooperation, applying inquiry-based learning, using e-library, wiki-portal, and availability of internet traffic. Thus, we can argue defining a component that combines separate features of space-semantic, technological, and communicative components and corresponds to trends in education.

Among the factors of university digital environment development (group 2) space-semantic component corresponds a lot to the theoretical model. The respondents assume that building a modern infrastructure and resources topology is a basis to build the university digital environment. The third factor included the variables connected to the educational and scientific communication (communicative component) and organization of the process of education (technological component). In the improved environment (group 2), the respondents consider communication resources and pedagogic strategies to be a part of the technological process. For example, preparation, organization, and participation in the conferences must be conducted in terms of learning (self-conducted work), researching, and leveraging training projects. The fourth factor, that we can call communicative and dissemination, has such features are participating scientific societies, using the social services, wiki portals, creating and supporting websites of departments, participating research projects, etc. Thus, we can assume this component to mostly correspond to the communicative component. Though, at the same time, it includes some features of the competency-based component, connected to the presentation of the achievements and reports automatization.

### **4.3 Development Analysis of the Ukrainian Universities Digital Learning Environment**

Comparing to the environmental expertise of 2013 [15] we can claim the results repeatability. The model of the university digital learning environment that we received by leveraging the factor analysis corresponds to the theoretical model of the infor-

mation and educational environment both for 1st and 2nd-factor groups. However, we observe the development that corresponds to modern requirements [3].

3. The research of 2013 didn't highlight the *competency-based component*. Though in the available environment (group 1) and in the improved environment (group 2) this component corresponds to the theoretical model. Therefore, it is possible to express assumptions regarding the strengthening of the competence potential of the digital learning environment. This doesn't only support improving digital literacy but also advancing digital equity.
4. In 2013, 2 factors corresponded to the *space-semantic component* of the theoretical model. The respondents told off the topology of resources and It infrastructure, that can tell us about a probable lack of resources in the universities. Today, students and teachers do not tell off the space-semantic component, and its features are generally considered together with the technological component. This can mean that the infrastructure, communication, and information support are sufficient, but the students are not involved enough. The teaching practices in the digital environment are generally created by teachers and oriented for the traditional process of education. In the improved environment (group 2) the space-semantic component corresponds to the theoretical model, and the respondents have clear requirements to the equipment and resources. This fact can be a basis to implement a course of individual studying and to start changes in the field of teaching considering the request and authentic learning experiences.
5. The *technological component* was defined in all groups, though its interpretation differs. In 2013 organization of the educational process depended on the teachers' digital competencies. In the 1st group environment it's the optimal combination of the infrastructure, resources topology and educational technologies. The improved 2nd group environment considers a scientific and educational communication as an educational technology. We can explain it with readiness to use digital environment in cooperation, in network communities, to develop it with personal experience to be up-to-date and correspond with trends in education, such as interdisciplinary studies i cross-institution and cross-sector collaboration.
6. The *communicative component* is also defined in all groups. In 2013, in the 1st group, these components corresponded to the theoretical model, while in the improved environment (2nd group) it's more about the outer communication that allows to making new connections, finding partners, experts, etc. The latest corresponds to the needs of cross-institution & cross-sector collaboration and adapting organizational designs to the future of work in the condition of digitalization. We should mention that distinguishing a component of collaboration and research in the 1st group environment can be a transition to the development of the communicative and dissemination component of the 2nd group.

## 5 Conclusions

We used factor analysis to confirm the theoretical model. We used it to find 4 main components that group all the factors of the digital educational environment into such

areas of focus as IT infrastructure and resources' provision, students' and teachers' digital competencies, scientific and educational communication between the students, teachers, and stakeholders, and educational process organization.

Comparing to the results of similar researches, even if we take into consideration the global development of the distance learning, online courses, open electronic resources, and redesigning learning spaces, we observed no significant changes on the main factors during the 2013-2018. However, messages, contents, and scopes change.

Both students and teachers claim that enabling digital learning environment as an improvement of the existing learning environment correlates to the mid- and long-term key trends accelerating higher education technology adoption: proliferation of open educational resources, the rise of new forms of interdisciplinary studies; advancing cultures of innovation, cross-institution & cross-sector collaboration. Effective implementation of the digital learning environment, both at the stage of designing and applying its methods, helps to overcome significant challenges impeding higher education technology adoption. Thus it empowers implementation of authentic learning experiences and improving digital literacy (solvable); adapting organizational designs to the future of work, advancing digital equity (difficult). However, having good enough IT-infrastructure, equipment, and level of digital competencies of the educational process participants, the solution of the problem depends more on the rethinking the roles of educators in the digital learning environment.

We consider the pedagogic design of the educational and scientific cooperation in the digital learning environment to be a prospective field for further research. We need to find out what factors influence the competencies of the digital environment participants most of all.

Repeating the digital learning environment expertise after a period of time for more respondents, and engaging participants (universities) from different countries will allow us to find out if the universities are ready for transformation to confirm the demands of the modern digital society.

## References

1. World Economic Forum World Economic Forum <http://www3.weforum.org/docs/GCR2018/05FullReport/TheGlobalCompetitivenessReport2018.pdf>, last accessed 2019/10/03.
2. The Digital Enterprise: moving from experimentation to transformation [http://www3.weforum.org/docs/Media/47538\\_Digital%20Enterprise\\_Moving\\_Experimentation\\_Transformation\\_report\\_2018%20-%20final%20\(2\).pdf](http://www3.weforum.org/docs/Media/47538_Digital%20Enterprise_Moving_Experimentation_Transformation_report_2018%20-%20final%20(2).pdf), last accessed 2019/10/03.
3. Becker, S., Brown, M., Dahlstrom, E., Davis, A., DePaul, K., Diaz, V. and Pomerantz, J.: NMC Horizon Report 2018: Higher Education Edition. Louisville, CO: EDUCAUSE, 2018, <https://library.educause.edu/~media/files/library/2018/8/2018horizonreport.pdf>, last accessed 2019/10/03.
4. Morze, N., Kuzminska, O., Protsenko, G.: Public Information Environment of a Modern University: ICT in Education, Research and Industrial Applications: Integration, Harmonization and Knowledge Transfer. CEUR Workshop Proceedings, pp. 264–272, <http://ceur-ws.org/Vol-1000/ICTERI-2013-p-264-272.pdf> (2013).

5. Bryson, C., & Hand, L.: The role of engagement in inspiring teaching and learning. *Innovations in Education & Teaching International*, 44(4), 349-362 (2007).
6. Kuzminska, O., Morze, N., Smyrnova-Trybulska, E.: Flipped learning model: Tools and experience of its implementation in higher education, *The New Educational Review* Vol. 49, No. 3, pp. 189-200. DOI: 10.15804/ner.2017.49.3 (2017).
7. Smyrnova-Trybulska, E., Noskova, T., Pavlova, T., Yakovleva, O. and Morze, N.: New educational strategies in the contemporary digital environment, *International Journal of Continuing Engineering Education and Life-Long Learning*, Vol.26 No.1, pp.6 – 24, DOI: 10.1504/IJCEELL.2016.075036 (2016).
8. Wheeler, S.: E-Learning and digital learning. In N. M. Seel (Ed.), *Encyclopedia of the sciences of learning*, pp. 1109–1111, New York: Springer (2012).
9. Smyrnova-Trybulska, E., Morze, N., Glazunova, O.: Design of a University Learning Environment for SMART Education, *Smart Technology Applications in Business Environments*, DOI: 10.4018/978-1-5225-2492-2.ch011 (2017).
10. Digital Learning Environment Manifesto, <http://manifesto.edutainme.ru/en>, last accessed 2019/10/03.
11. Drlik, M., Švec, P., Kapusta, J., Munk, M., Noskova, T., Pavlova, T., Yakovleva, O., Morze, N., Smyrnova-Trybulska, E.: Identification of Differences in University Environment between Selected EU and Non-EU Countries Using Knowledge Mining Methods: Project IRNet Case Study, *International Journal of Web Based Communities (IJWBC)*, Vol. 13, No. 2, DOI: 10.1504/IJWBC.2017.10004116 (2017).
12. Center for Studies in Higher Education. The University of California, Berkeley, 2009, <https://cshe.berkeley.edu/seru>, last accessed 2019/10/03.
13. Quality management principles, <https://www.iso.org/files/live/sites/isoorg/files/archive/pdf/en/pub100080.pdf>, last accessed 2019/10/03.
14. Witzl, M., Dompfeler, H.: How to create a digital learning environment consisting of various components and acting as a whole?, [http://www.eunis.org/download/2017/EUNIS\\_2017\\_paper\\_16.pdf](http://www.eunis.org/download/2017/EUNIS_2017_paper_16.pdf), last accessed 2019/10/03.
15. Panchenko, L.: Modeling the Informational Educational Environment of University with Factor Analysis, *Bulletin of the University of Luhansk*, № 10 (269), P. III, pp. 6-17, [http://nbuv.gov.ua/UJRN/vluf\\_2013\\_10\(3\)\\_3](http://nbuv.gov.ua/UJRN/vluf_2013_10(3)_3) (2013) (in Ukrainian).
16. Reproducibility gold standard, <https://www.coursera.org/learn/data-results/lecture/KOraT/reproducibility-gold-standard>, last accessed 2019/10/03.
17. Kuzminska, O., Mazorchuk, M., Morze, N., Pavlenko, V., & Prokhorov, A.: Digital Competency of the Students and Teachers in Ukraine: Measurement, Analysis, Development Prospects. In: *Information and Communication Technologies in Education, Research, and Industrial Applications*, *Communications in Computer and Information Science*, vol. 2104, p. 366-379 (2018).
18. Levesque, R.: *SPSS Programming and Data Management, 2nd Edition A Guide for SPSS and SAS Users*. Chicago: SPSS Inc. (2005).
19. Carmines, E., Zeller, R.: *Reliability and validity assessment*. London, Sage Publications, Quantitative applications in the social sciences series no. 17 (1979).
20. Kutner, M., Nachtsheim, C., Neter, J., and Li, W.: *Applied Linear Statistical Models*, McGraw-Hill/Irwin, Homewood, IL. (2004).
21. Jolliffe, I.: *Principal Component Analysis, 2nd Edition*. Springer-Verlag New York, Secaucus, NJ. (2002).



# The Blended Methodology of Learning Computer Networks: Cloud-based Approach

Oleg Spirin<sup>1</sup> [0000-0002-9594-6602], Vasyli Oleksiuk<sup>2</sup> [0000-0003-2206-8447], Nadiia Balyk<sup>3</sup> [0000-0002-3121-7005], Svitlana Lytvynova<sup>4</sup> [0000-0002-5450-6635], Sergiy Sydorenko<sup>5</sup> [0000-0001-7265-559X]

<sup>1</sup> University Of Educational Management of NAES of Ukraine  
52 A, Sichovykh Striltsiv Street, Kyiv, Ukraine  
oleg.spirin@gmail.com

<sup>2,3</sup> Ternopil Volodymyr Hnatiuk National Pedagogical University  
2 M. Kryvonosa St., Ternopil, Ukraine  
{nadbai, oleksyuk@fizmat.tnpu.edu.ua}

<sup>4</sup> Institute of Information Technologies and Learning Tools of NAES of Ukraine,  
9 M. Berlynskoho St., Kyiv, Ukraine  
{s\_litvinova@i.ua, svsydorenko@gmail.com}

**Abstract.** The article considers the use of blended learning as an effective methodology of encouraging students' cooperation in the process of solving practical problems and as a means of developing their essential professional skills. The following pedagogical approaches and techniques of blended learning are discussed: combination of face-to-face and distance learning, group members' partnership, development of group work skills, heterogeneous grouping, combined use of individual and peer assessment, teacher's monitoring of the students' work, task-oriented approach, chance for every member to be a leader, essential feedback. The authors suggest using private and public cloud technologies in an integrated academic cloud to support the implementation of group methodology in the teaching process. The analyzed academic cloud includes Apache CloudStack and EVE-NG Community platforms. This cloud environment was deployed at Physics and Mathematics Department of Volodymyr Hnatiuk National Pedagogical University of Ternopil (Ukraine). The developed methodology is used in course "Computer Networks". It has been verified experimentally by using appropriate statistical methods.

**Keywords:** blended learning, ICT-competence, cloud-based environment, Apache CloudStack, EVE-NG Community, computer science trainee teachers.

## 1 Introduction

Development of cloud technologies visibly affects both the aims and the content of ICT education. In view of this, researchers are currently looking for new and improving the existing forms and methods to combine the benefits of face-to-face and online learning.

Today it is important to develop methodological principles of blended learning in training students. Various aspects of developing blended learning in an information society have been studied by C.J. Bonk, C.R. Graham, A.G. Picciano, C.D. Dziuban [1], [14].

Works of D.R. Garrison, N.D. Vaughan, H. Kanuka [6], [7] offer the ways to improve the effectiveness of the educational process at higher educational institutions. Some aspects of using blended learning as an effective model of building ICT competence have been researched by U. Köse [10]. N.P. Napier, S. Dekhane, S. Smith, R. Collopy, J.-M. Arnold describe the experience of blended learning organization from the perspective of teaching a specific discipline [12], [2].

In view of the appropriateness of using cloud technologies for systemic implementation of the principles of blended learning and activity approach, as well as for hands-on in-context learning based on cooperation, these technologies are seen as an effective teaching tool in training computer science teachers.

For higher educational institutions, deployment and use of cloud-based environment remains a priority, a prerequisite for effective addressing of current educational challenges.

O. Glazunova and M. Shyshkina in the paper [8] develop the concept of cloud-oriented educational scientific environment of a higher educational institution. Various aspects of introducing such environment in educational practice have been researched by O. Pinchuk, S. Lytvynova, O. Burov. The authors conclude that the effective learning environment should be immersive, creating the effect of "immersion" on the part of a student [15]. H. Kravtsov and V. Kobets in their study develop the model of the curriculum revision system in computer science. The authors single out generic competences for Master program in Information Systems [11]. O. Spirin and O. Holovnia suggest a variant approach to the application of virtualization technologies in the training of computer science bachelors. This approach involves integration of several virtualization tools and appropriate adaptation of training materials [17]. Yu. Nosenko's paper [13] studies cloud technology in Open Education Space.

Cloud-oriented environment of an educational institution, which combines hardware, software and information resources and services, functions on the basis of cloud computing technologies and provides the academic process with the resources of the university's local network and Internet access. University clouds are aimed, above all, at facilitating personal development of the faculty and students, encouraging their professional self-realization.

**The goal of this article** is to design the cloud-based environment for learning computer networks and to research effectiveness of blended learning in such environment.

## **2 Presentation of the main results**

Currently, a major challenge in training computer science teachers is adjustment of education content and tools to the continuous advance of information technologies. This problem can be solved by means of combining students' theoretical education

and practical training, on the one hand, and increasing the effectiveness of their self-study through creative tasks and project methodology, on the other. Such approach lies at the basis of the blended learning concept. Literature on the subject makes use of several terms, among them hybrid, mixed, integrative, blended learning, technology-mediated instruction, web-enhanced instruction, mixed-mode instruction. The main interpretations of the concept are as follows:

1. A learning process which combines traditional and innovative technologies - electronic, distance, mobile learning.
2. Mixed learning combines various pedagogical approaches (e.g. constructivism, behaviourism, cognitivism) to achieve the optimal effect.
3. Mixed learning combines technological teaching facilities and face-to-face learning under the teacher's supervision.
4. Mixed learning combines traditional teaching with solving hands-on professional tasks.

Currently, researchers tend to look at the blended learning as a synergetic concept (a system of ideas, theories, models, levels, methods and tools of organizing educational activities) characterized by a new vision of the process and results of learning.

We see the following benefits of blended learning of computer science trainee teachers:

- blended learning improves students' performance, especially when ICT-technologies support cognition (for instance, in modeling) or facilitate students' interaction with other students and the teacher;
- blended learning changes the role of the teacher, who becomes a facilitator in students' research, a manager of educational projects;
- the traditional classroom is converted into an open virtual space, where students can study at their own speed;
- students' motivation for self-study and self-improvement increases;
- study based on reproduction and repetition is transformed into the process of discovering knowledge and presenting the results of such discovery;
- students get an opportunity to go through all stages of creating an IT-product, from an idea to creating a model, and then to final realization and testing.

In the previous study we developed a group methodology of using university cloud, which involves the project method as an effective tool of encouraging students' cooperation while solving practical problems and as a means of developing their essential professional skills [16]. At the second stage of our research we further developed the proposed methodology of blended learning in the course "Computer Networks", drawing on the approaches suggested in [9].

The essential characteristics of the used methodology are:

- transformation of a classroom into a virtual cloud laboratory;
- unlimited access of students and teachers to the objects of study;
- combination of formal and informal modes of study;

- focus on visibility, necessitated by the fact that virtual objects are often not easy for students to perceive and comprehend;
- combination of face-to-face and online communication, of self- and teacher directed instruction;
- achievement of personal and group goals.

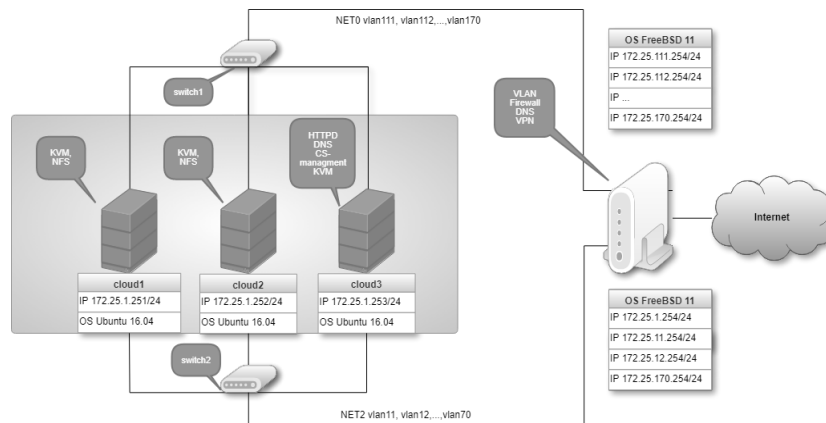
The components of the educational model of blended learning include [5]:

- specification of mixed learning environments, modes of interaction and corresponding resources and facilities;
- study of knowledge attainment options;
- knowledge organization decisions.

It is important that the content be structured, in particular, by means of singling out the key concepts. Here the course developers can use a three-dimensional educational project, which includes key concepts, basic facts and basic skills required to perform the tasks [4].

For the course "Computer Networks", we enhanced the academic cloud, modifying its infrastructure so as to be able to create a lot of virtual subnetworks. Each of these subnetworks can be associated with a certain physical hypervisor network. Traffic marking in these networks is done using virtual local area network (VLAN) technology. Correspondingly, on the basis of OS FreeBSD, we configured a router to transmit data between VLAN.

Addition of these networks should not require changes in the topology of physical networks in the cloud-based environment. We divided the traffic transmitted between students' virtual computers among 120 VLANs. With such number of VLANs available, each student has an opportunity to store their virtual computers and other devices in their personal or several guest networks. That is, each of the virtual machines can be supplied with network adapters working in different subnetworks. The general layout of the expanded cloud infrastructure looks like this:



**Fig. 1.** Diagram of the cloud infrastructure

To determine the correspondence between physical adapters and traffic in CloudStack system, they are marked by VLAN tags. As a result, physical network adapters installed on hosts cloud1, cloud2, cloud3 are aggregated by the system in two. The traffic of these adapters is transmitted via switch1 and switch2 to the router. As our main task was to deploy separate guest subnetworks, the corresponding traffic is also marked by separate tags. For each of the tags, we created network offering templates, which give the possibility to indicate services to be functioning in the corresponding network. In our cloud infrastructure, such services include a DHCP-server, a NAT-translator, a firewall, a traffic load balancer and others. For these services to function, in each guest network Apache CloudStack platform creates a system virtual machine, virtual router. These services work in virtual networks vlan11, vlan12, ..., vlan70.

Networks vlan11, vlan12, ..., vlan70 do not contain any Apache CloudStack services and are switched on L2 level of OSI model. That means that using virtual machines in these networks requires that students configure network parameters manually.

As Apache CloudStack does not provide tools for visualization of network structure, students often have difficulty in designing and configuring networks in a cloud infrastructure. That fact prompted us to integrate into a university cloud a system that makes it possible to visualize the process of network design. It was vital that such system could work with networks on Apache CloudStack virtual machines. We analyzed relevant publications and compared several platforms – Cisco packet tracer, Graphical Network Simulator (GNS), Unetlab (EVE-NG) (Table 1).

**Table 1.** Comparing Simulation Platforms for Computer Network Learning

<b>Parameter</b>	<b>GNS3</b>	<b>Cisco Packet Tracer</b>	<b>EVE-NG Community</b>
Installing	Medium	Simple	Simple
Web (graphic) UI	Yes	Yes	Yes
CPU load	High	Medium	Medium
Free download	Yes	Yes	Yes
Routers	Yes, Cisco (not free)	Yes	Yes, Cisco (not free)
Additional components	Need to install	All in one	All in one
Integration with Apache CloudStack	+	-	+
Support external and internal (own) networks	+	-/+	+

Our choice fell on ENE-NG Community. Every student's copy of ENE-NG platform is a separate virtual machine in Apache CloudStack cloud. As each node of EVE-NG is itself a virtual machine, hosts integrated in Apache CloudStack infrastructure have to support nested virtualization.

Here are the main advantages of its use in teaching computer networks:

- visualization of network structure via web-interface;
- possibility to manipulate objects in web-browser;
- free EVE-NG Community version;
- possibility to work on a OS Linux based virtual machine;
- availability of personal templates of virtual machines and network equipment;
- support of external (for the student) networks and availability of personal networks;
- availability of integrating tools for remote access and network connections monitoring.

We can positively affirm that our academic cloud integrated virtual networks of Apache CloudStack via EVE-NG platforms.

Our methodology provides for the use of the university cloud-based environment for building basic competences and in carrying out group projects.

We determined the content of teaching computer networks on the basis of the domain ITE-NET from Information Technology Curricula 2017 [3]. It contains the following subdomains:

- ITE-NET-01 Perspectives and impact;
- ITE-NET-02 Foundations of networking;
- ITE-NET-03 Physical layer;
- ITE-NET-04 Networking and interconnectivity;
- ITE-NET-05 Routing, switching, and internetworking;
- ITE-NET-06 Application networking services;
- ITE-NET-07 Network management.

To study the effectiveness of our blended learning methodology we divided the students into two groups:

- Group 1 – control group (CG), in which students throughout the course had classroom instruction with a teacher and studied on their own out of class; the students used real network devices and computers in class and their personal equipment for self-study at home;
- Group 2 – experimental group (EG), in which students studied the topics ITE-NET-01 – ITE-NET-03 in class with a teacher and the topics ITE-NET-04 – ITE-NET-07 using our methodology of blended learning involving university cloud services.

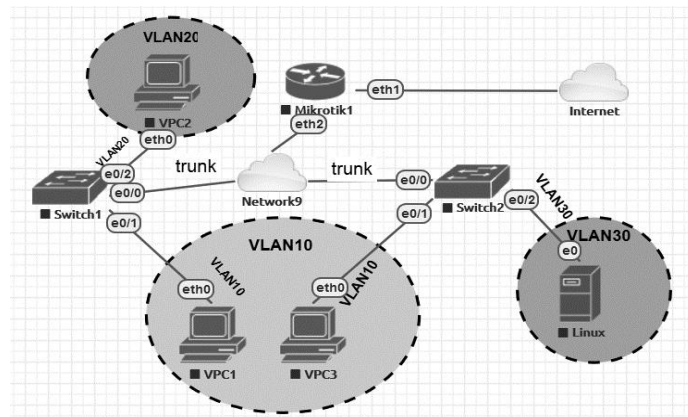
Thus, our methodology involved the use of the academic cloud to model data transmission between virtual computers during classroom and distance learning as well as to organize group work.

We began the use of EVE-NG platform with the study of network topologies. The students designed network topologies on the basis of "building blocks", such as switches, routers, and cabling.

Principles of data transmission on channel and network levels were studied on the basis of VLAN technology. Doing such tasks, EG students used various virtual nodes of EVE-NG platform:

- management L2-switch Cisco IOL (for example, i86bi-linux-l2-adventerprise9);
- routers Mikrotik;
- OS Ubuntu Linux Server;
- built-in node "Virtual PC".

EVE-NG platform networks served as models of unmanaged switches. Fig. 2 shows an example of the described network topology:



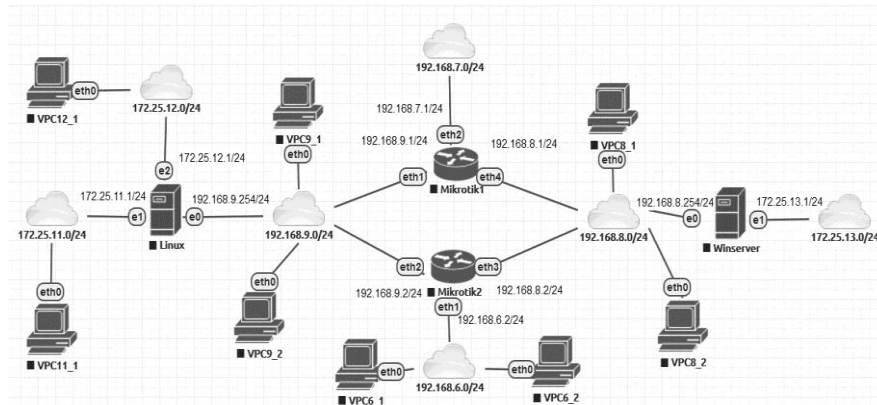
**Fig. 2.** Network topology with VLAN

The example shows that the designed university cloud provides all the necessary conditions for realization of the blended learning methodology. In particular, students can work on their tasks both in face-to-face and in online (via VPN-connection) modes, being able to cooperate both in class and remotely. In case of group work we suggest that students perform similar tasks, for instance, one student configuring switch 1, another – switch 2, etc. The task can be extended by one student configuring access-ports for switch 1 and another configuring trunk-ports. The teacher also has access to all virtual machines and nodes, being able to help students, supervise and control their.

EVE-NG platform gives access to nodes via the standard protocols telnet and vnc. If several students connect via these protocols to the same node, they will work with that VM simultaneously. Access via telnet and vnc protocols does not depend on the parameters of TCP/IP protocols. That means that students have the possibility to make mistakes and learn without running the risk of losing control of their nodes.

An important task in designing a network is monitoring the connections. To handle this task, we used Wireshark utility from EVE-NG integration pack.

We went on to study the topics of ITE-NET-07 subdomain (Network management) on the basis of an extended topology with many routers (Fig. 3).



**Fig. 3.** Example of network with many routers

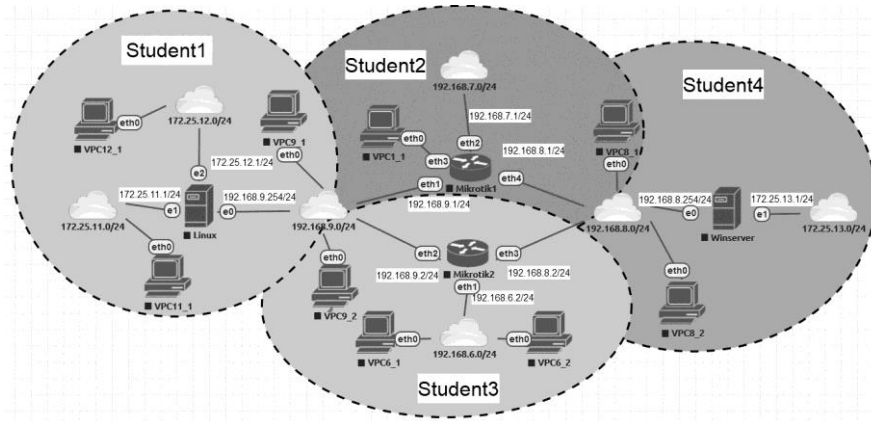
We used this configuration to look at the following issues:

- static routing;
- basic and NAT routing;
- dynamic routing protocols;
- load-balancing some Internet channel;
- policy Base Routing;
- data filter with firewall;
- network protocols and services (DHCP, ARP, DNS);
- virtual private network protocols (PPTP, L2TP, OpenVPN).

It is worth noting that in the example shown in Fig. 6, networks with 192.168.0.0/16 prefix are internal. They can be viewed as models of local networks working by TCP/IPv4 protocol. Students' routing between such networks does not happen. Networks with prefix 172.25.0.0/16 are connected to Apache CloudStack cloud infrastructure. They can be viewed as models of external networks connected to various Internet Service Providers. The proposed topology can be upgraded by transferring to IPv6 protocol. By doing this, every device in students' networks can be given a real IPv6-address.

Several groups of students can be offered to change the addressing of their internal networks so as to provide static or dynamic routing between them. Also, the complex topology (Fig. 3) can be divided among students in such a way that each student will configure one of its components (Fig. 4). For such group work we used projects – specific organizational units of Apache CloudStack platform. Apache CloudStack project is a group of virtual machines which can be accessed by the project participants. Our project involved 4 virtual machines with EVE-NG platform, which, in different sequence, were operated by 4 students.





**Fig. 4.** Division of the topology among students

To complete the study of the topic ITE-NET-07 Network management, we asked students to carry out group project "DIY your own ISP". The major tasks of the project were:

- designing topology of the students' own network;
- making provisions for the possible expansion of the topology;
- isolating clients' computers from one another;
- blocking unwanted or harmful traffic (floods, broadcasts);
- dynamic allocation of IP-addresses from various pools (actual on the Internet and local in the provider's local networks);
- traffic shaping;
- storing user statistics;
- user database management.

While working on the project, the students had maximum independence. They themselves distributed roles in the group, analyzed billing systems, designed the network, chose the necessary equipment, configured connection switches and routers, installed the billing system, tested the network performance and analyzed its drawbacks.

At the second stage of their work, students systematically used services of the public clouds Google Suite and Microsoft Office 365. In particular, they together created protocols of network topology nodes testing, graphs of their speed characteristics and summing-up reports on task performance.

To verify the effectiveness of the proposed methodology, we conducted one more research. After completion of the topics ITE-NET-01 – ITE-NET-03, we conducted a test (TEST1-NET-01-03) to assess the academic achievement of students in the control and experimental groups. The test was assessed on the 100-point scale. For each group, we got a total of grades. Fig. 5 shows a descending distribution of the students' grades in TEST1-NET-01.

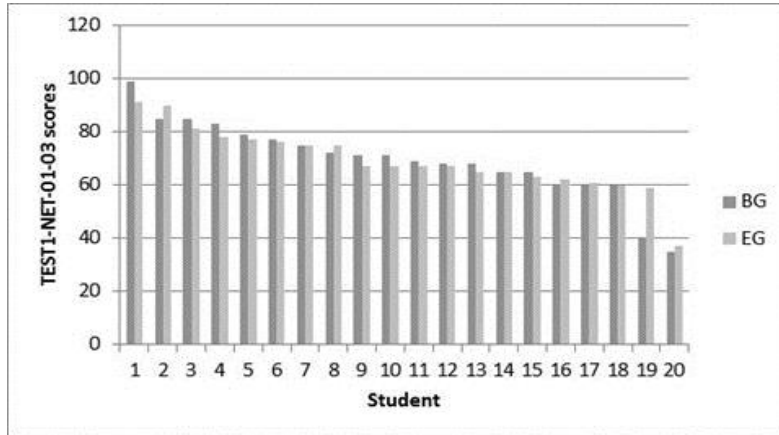


Fig. 5. Grades distribution in TEST1-NET-01-03

Using One-Sample Kolmogorov-Smirnov Test, we found out that the grades are distributed by normal law (2-tailed asymptotic significance for CG and EG:  $\alpha_{CG}=0,178$ ;  $\alpha_{EG}=0,127$  ). Thus, to check whether there are statistical differences between the groups, we can use Independent Samples Student's t-test. The statistical data of Independent Samples Student's t-test are given in Table 2.

Table 2. Statistical data of Independent Samples Student's t-test after studying ITE-NET-01 – ITE-NET-03 topics

		Levene's Test for Equality of Variances		t	df	Sig. (2-tailed)
		F	Sig.			
TEST1- NET-01- 03 scores	Equal variances assumed	0,232	0,633	0,047	38	0,963
	Equal variances not assumed			0,047	36,552	0,963

The table shows that Levene's Test for Equality of Variances data prove the correct choice of the statistical method. As the significance exceeds 0.05, we can state that after studying the topics ITE-NET-01 – ITE-NET-03 students in the control and experimental groups showed no statistical differences in their academic achievement.

The students of both groups then went on to study topics ITE-NET-04 – ITE-NET-07. The content of the topics was the same for both the groups, and the instruction was provided by the same teacher. The students of the control group continued working with the real equipment in class and with their own devices out of class. The students of the experimental group worked by our proposed blended learning methodology. After the students completed topics ITE-NET-04 – ITE-NET-07, we again conducted a test (TEST2-NET-04-07). Its results are shown in Fig. 6.

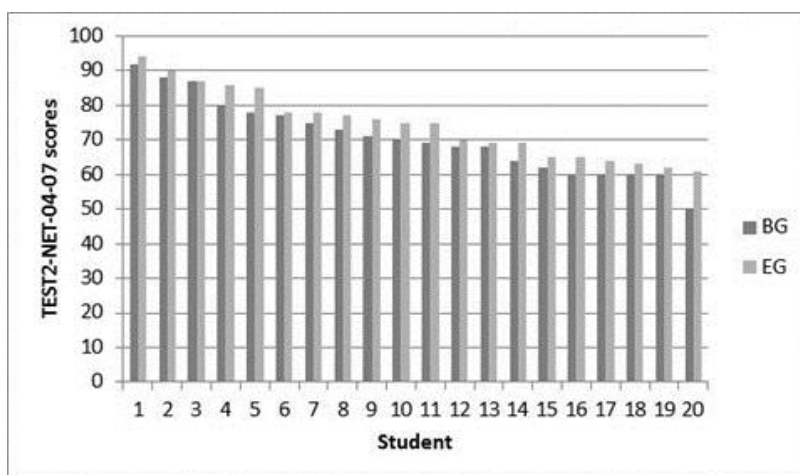


Fig. 6. Grades distribution in TEST2-NET-04-07

We used One-Sample Kolmogorov-Smirnov Test and made sure that the grade distribution in TEST2-NET-04-07 was normal. So, to check statistical differences between the grades received in TEST1-NET-01-03 and TEST2-NET-04-07 we used Dependent Student's t-test for paired samples. Differences between the grades received in TEST1-NET-01-03 and TEST2-NET-04-07 were compared separately for the control and experimental groups. Corresponding statistical data are shown in Table 3.

Table 3. Statistical data of Dependent Student's t-test for paired samples after studying ITE-NET-04 – ITE-NET-07 topics

	Paired Differences			t	df	Sig. (2-tailed)
	Mean	Std. Deviation	Std. Error			
Pair 1 TEST1_CG_scores - TEST2_CG_scores	-1,250	5,973	1,336	-0,936	19	0,361
Pair 2 TEST1_CG_scores - TEST2_CG_scores	-5,300	5,105	1,140	-4,647	19	0,000

Taking into consideration that  $Sig_{EG} < 0,05$ , we can claim that there exist statistical differences between academic performances of EG students. Such conclusion can not be made concerning CG students. This confirms the effectiveness of the proposed methodology of blended learning at the second stage of our research.

### 3 Conclusions

The designed and deployed cloud-based environment provides:

- access to cloud resources through a web browser;

- simulation of network topologies in a web browser;
- service as needed – the student can immediately get the system resources;
- universal access to the network infrastructure of the student according to the IaaS model;
- elasticity and scaling of computing resources.

Our research showed that combination of face-to-face and online learning allows teachers to make use of the technological benefits offered by the academic cloud to achieve the study goals. Blended learning facilitates more rational use of resources and time, the process of study becomes more open, students have the possibility to learn how to manage their learning process and appear to be much better prepared for successful completion of the course.

This research has experimentally proved the efficiency of the blended learning methodology in training computer science trainee teachers. Suggested educational projects raise students' cognitive interest, allow them to develop essential professional skills, ability to work in a team and sense of responsibility for their joint effort.

## References.

1. Bonk, C.J., Graham, C.R.: The handbook of blended learning: Global perspectives, local designs. John Wiley & Sons. (2012)
2. Collopy, R.M., Arnold, J.M.: To blend or not to blend: Online-only and blended learning environments. *Issues in Teacher Education*, vol. 18(2), pp. 85-101, (2009)
3. Curriculum Guidelines for Baccalaureate Degree Programs in Information Technology.: Association for Computing Machinery & IEEE Computer Society, (2017)
4. Erickson, H. L.. *Concept-based curriculum and instruction for the thinking classroom*. Thousand Oaks: Sage Publications Ltd., (2007)
5. Galvis, A.H.: Supporting decision-making processes on blended learning in higher education: literature and good practices review.: *International Journal of Educational Technology in Higher Education* vol. 15(1), (2018)
6. Garrison, D. R., Kanuka, H.: Blended learning: Uncovering its transformative potential in higher education. *The Internet and Higher Education*, vol. 7(2), pp. 95–105, (2004)
7. Garrison, D. R., Vaughan, N.D.: *Blended learning in higher education: Framework, principles, and guidelines*. John Wiley & Sons, (2008)
8. Glazunova, O., Shyshkina, M.: The Concept, Principles of Design and Implementation of the University Cloud-based Learning and Research Environment. online: [http://ceur-ws.org/Vol-2104/paper\\_158.pdf](http://ceur-ws.org/Vol-2104/paper_158.pdf), (2018)
9. Kintu, M. J., Zhu C., Kagambe E.: Blended learning effectiveness: the relationship between student characteristics, design features and outcomes.: *International Journal of Educational Technology in Higher Education*, vol. 14(7), (2017).
10. Köse, U.: A blended learning model supported with Web 2.0 technologies. *Procedia-Social and Behavioral Sciences* 2.2, (2010)
11. Kravtsov, H., Kobets, V. Model of the Curriculum Revision System in Computer. online: [http://ceur-ws.org/Vol-2104/paper\\_158.pdf](http://ceur-ws.org/Vol-2104/paper_158.pdf), (2018)
12. Napier, N.P., Dekhane, S., Smith, S.: Transitioning to blended learning: Understanding student and faculty perceptions. *Journal of Asynchronous Learning Networks* 15.1, pp. 20-32. (2011). online: <https://files.eric.ed.gov/fulltext/EJ918216.pdf>

13. Nosenko, Yu.: Cloud technology in open education space. In: The Modeling and Integration of Cloud Oriented Services of Learning Environment, pp. 24–34. Comprint, Kyiv (2015)
14. Picciano, A.G., Dziuban, C.D., Graham, C.R.: Blended learning: Research perspectives. Vol. 2. Routledge (2013)
15. Pinchuk, Olga, Svitlana G. Lytvynova, & Oleksandr Yu. Burov. "Synthetic Educational Environment – A Footpace To New Education." Information Technologies and Learning Tools. online: <https://journal.iitta.gov.ua/index.php/itlt/article/view/1831>, 60.4 (2017).
16. Spirin, O. Oleksiuk, V., Oleksiuk, O., Sydorenko, S. The Group Methodology of Using Cloud Technologies in the Training of Future Computer Science Teachers. Online:, [http://ceur-ws.org/Vol-2104/paper\\_158.pdf](http://ceur-ws.org/Vol-2104/paper_158.pdf) (2018)
17. Spirin, O., Holovnia O, Using Unix-Like Operating Systems Virtualization Technologies In Training The Bachelors Of Computer Science. Information Technologies and Learning Tools, 65 (3), online: <https://journal.iitta.gov.ua/index.php/itlt/article/view/2055/1349> (2018)

# The Method of Using the Maxima System for Operations Research Learning

Mariya Shyshkina<sup>1</sup>, Uliana Kohut<sup>2</sup>

<sup>1</sup>Institute of Information Technologies and Learning Tools of NAES of Ukraine,  
9 M.Berlynskoho St., Kyiv, Ukraine  
shyshkina@iitlt.gov.ua

<sup>2</sup>Drohobych Ivan Franko State Pedagogical University, 24 I. Franko Str., Drohobych, Ukraine  
ulyana3001@gmail.com

**Abstract.** In the article, the problems of using the systems of computer mathematics (SCM) as a tool to support the teaching and research activities in the field of informatics and mathematics disciplines training are investigated. The role of SCM in the process of bachelors of informatics training and special aspects of pedagogical applications of these systems in the “Operations research” study is defined. The aim of the article is the justification of the Maxima system use of in the process of “Operations research” teaching in pedagogical university as enchasing the investigative approach to learning and determination of the perspective ways of its introduction. The main characteristics of SCM Maxima and the ways of access organizing to it both in local and the cloud-oriented implementation are considered. The results of the pedagogical experiment on the Maxima application to support the investigative approach to operation research study and the analysis of its conclusions are reported.

**Keywords:** “Operations research”, Maxima, learning tools, investigative approach, Cloud computing, mathematical disciplines, learning environment, educational university.

## 1 Introduction

### 1.1 Research objectives

In the modern information-educational environment there are new models of the learning activity organization, that are based on innovative technological decisions of environment infrastructure organization including the cloud oriented.

The question of adjusting the information-technological infrastructure of the educational institution to the necessities of users, and organization of facilities and services of this environment in order to realize as much as possible the pedagogical potential of modern ICT, to attain the increase of learning results and also the improvement of the process of research activity of the students the innovative approaches are in demand. These approaches are to provide the most advisable ways of access organ-

ization to systems of computer mathematics, that are among the leading types of learning tools of mathematics and informatics.

The teaching "Operations research" in the system of specialists of informatics training in the pedagogical university play the special important role as it combines both the fundamental concepts and principles of different mathematics and informatics disciplines and applied models and algorithms of their implementation. There are the basic research approaches to the processes of mathematical modeling, decisions making, and mathematical description of the basic concepts and principles of data processing that are the subjects of computer modeling in informatics.

The use of SCM in the process of "Operations research" studies allows (i) to change the accents in the selection of theoretical material, (ii) to increase the fraction of tasks on mathematical models construction of the real optimization tasks and their research by means of SCM; and (iii) to introduce the tasks on comparison of the results, obtained by means of the numeral methods of optimization, described by one of programming languages and builtin SCM tools, and their analysis at different input data, as well as the tasks on programming in the environments of mathematical packages of numerical methods of optimization and their research.

**The aim of the article** is the justification of the Maxima system use of in the process of "Operations research" teaching in pedagogical university as enchasing the investigative approach to learning and determination of the perspective ways of its introduction.

## 1.2 Problem statement

The analysis of the domestic and international experience of the use of ICT in the process of informatics disciplines learning testifies that such class of ICT-based learning tools as the systems of computer mathematics(SCM) constantly attracts attention of researchers 1, 2, 3, 4. These systems, that are complex, multifunctional, powerful enough and at the same time simple in the use, become irreplaceable in maintenance of various processes of numerical accounts, patterns visualization, realization of symbol operations, algorithms and procedures 5, 4. SCM is the environment for the projecting and use of programming tools of the maintenance of informatics disciplines teaching, forming innovative pedagogical technologies.

In recent years, informatics disciplines learning tools and technologies have obtained a further development, in particular based on the concept of cloud computing. This conception significantly changes the existing views on the organization of access and integration of applications, so there is a possibility to manage larger ICT infrastructures, that allow to create and to use both individual and collective "clouds" in a cloud-oriented educational space 6, 5.

Localization of such tools for educational purposes as SCM "in the cloud" is perspective direction of their development, when there are more possibilities of adapting the teaching environment to academic achievement, individual needs and goals of the learners. The "spectrum" of research activities is expanding both due to the fundamentalization of IT disciplines and the content of teaching as well as extending access to research tools. In this regard, we must pay attention to issues of grounding theoretic-

cal and methodical bases of introduction and use of SCM, the definition of advantages and disadvantages of different approaches to deployment, research and analysis of the experience of their implementation.

Methodical peculiarities of teaching optimization methods and “Operations research” using WEB-SCM are analyzed in the work of Trius Y. V. 7. The graphical interface of SCM Maxima for modeling animations is described in detail in the work of Bugaets N.O. and examples of creating the animation evidentness models and their use are made for development of educational-research abilities 8.

The methodical aspects of using SCM Maxima in the process of “Operations research” teaching comes to the fore. It is aimed at the forming students’ ICT-competences, including in a cloud-based environment due to: the acquaintance with functional characteristics of SCM Maxima; developing skills of mathematical research of the applied tasks, in particular, the construction of mathematical models; mastering programming in the SCM Maxima; obtaining the necessary knowledge base for studying other disciplines; increasing the level of informatics acquirement by means of the extensive use of SCM and cloud-oriented systems in the educational process and research work.

### **1.3 Research Methods**

The study is based on the methods of theoretical analysis, generalization and systematization of scientific facts about the pedagogical processes and phenomena, methods of system analysis and modeling, pedagogical observations and generalization of pedagogical experience, as well as the results of the pedagogical experiment. The study was carried out in the framework of the implementation of the planned research undertaken in the Institute of Information Technologies and Learning Tools of NAES of Ukraine and the Department of Informatics and Computing Mathematics of the Drohobych Ivan Franko State Pedagogical University. In the process of research the scientific-methodical principles of using the cloud-based component on the basis of the Maxima system in the process of informatics disciplines teaching for computer specialists have been grounded and analysed.

Such interdisciplinary methods and procedures are used in informatics as analysis and synthesis, induction and deduction, visualization and formalization, algorithmization and programming, informative-logical, mathematical and computer modeling, program management, expert evaluation, identification and others. It is necessary to acquire them in complex, otherwise there is not a sufficient level of mastering the material of informatics disciplines.

## **2 Results and Discussion**

### **2.1 The most important features of the Maxima system from the didactic process point of view**

In the conditions of informative society formation it is very important to prepare highly skilled specialists, capable to undertake productive work in this society. Therefore



it is necessary to search for new methodological approaches to organization of learning that would assist the deep mastering and understanding of basic concepts, rules, principles and methods of disciplines studies, their relationship to contiguous disciplines, and ways of their use in practice. The perspective direction is the integration of the systems of computer mathematics in the process of “Operations research” teaching. These systems may help, on the one hand, to automate some routine actions, focusing students on mastering the concepts and principles that are studied, and on the other hand, to identify the interdisciplinary links of various disciplines, examining how certain fundamental concepts are implemented in applications.

The use of the cloud-based tools of SCM design is a significant factor in the expansion of access to them in the process of teaching and research activities in the field of informatics and mathematics. If research activity happened only in specially created situations in the case of application of a local version of the tool, more attention can be paid to the independent work with using a cloud-oriented version, and research activity is extended outside the classroom time 5.

The use of mathematical packages to solve practical problems involves (i) understanding the problems of the educational discipline for proper use of SCM; (ii) understanding the methodology of developing the algorithm from the mathematical ideas to the formulation and the ability to apply this methodology; and (iii) the ability to carry out grounding and estimation of the algorithm complexity at run-time and memory requirements [4, p. 138].

For scientific purposes the choice of SCM depends on the input data and result to be obtained. For example, the analytical model of the investigated phenomenon or object is more interesting for a physicist-theorist, so it is better to use the packages, such as Mathematica, Maple and Maxima. Physicists-experimenters would rather use the MATLAB system for large data sets processing 4, p. 138].

Special attention should be paid to Maxima system, as it is easy in learning, in solving the problems does not yield to such systems as Maple and Mathematica and is freely distributable. It is equipped with a menu system that allows performing symbol conversions, to solve equations, to compute limits, derivatives, integrals and the like, not knowing the language for the description of the commands to perform these actions. Therefore the Maxima system can be used for informatics and mathematics disciplines learning even on the first course of pedagogical university 4. Maxima system application will not cause any difficulties for students in solving tasks of mathematical analysis and linear algebra – the students are required only to select a menu item and enter the expression. However, for programming in Maxima system one needs knowledge of language and syntax, as well as certain commands [4, p.138].

“Operations research” teaching of pre-service specialists requires special attention as it combines both the fundamental concepts and principles of different mathematics and informatics disciplines and applied models and algorithms for their application.

The goal of SCM using in the process of pre-service specialists training in Informatics is the formation of the ability for successful using the information technologies in their professional activities, creative approach to solving non-standard problems, deep mastering the fundamentals of the disciplines. For this purpose the methodology of SCM using in the process of “Operations research” teaching was developed, aimed

at (i) the formation of the professional competences of future specialists in Informatics that will give an opportunity in the future to adapt oneself to the requirements of informative society; (ii) the development of the creative approach to solving non-standard tasks; and (iii) the formation of mathematical skills needed for analyzing, modeling and solving theoretical and practical problems with application of SCM 5. The use of this technique was the subject of the present experimental studies with the application of both local and cloud-oriented implementation of SCM Maxima.

One of the important use of SCM Maxima in scientific investigations and at the mathematics and informatics disciplines learning at higher school is the solution and study of the optimization problems arising in various fields of human activities.

Due to the introduction of SCM Maxima into the "Operations research" teaching process the opportunity is occurred to focus students on key concepts, principles, approaches, releasing time and efforts that are spent on the software establishment, maintenance, and even greatly to mitigate the real spatial and temporal boundaries of the implementation of access to necessary electronic resources. This approach develops interdisciplinary links, assists the deep study of material, and extends possibilities of independent research, the combination of theory and practice, knowledge integration concerning the various departments and levels of computer education 4, 5.

For this purpose the technology of "virtual desktop" may be applied, where the data storage and processing are happened in the data center. Also, for a user, the work with cloud supplements, appealed via the Internet browser, does not differ from the work with software installed on a desktop of the user's personal computer 5.

The use of software that is installed on the student's virtual desktop (i) does not require spending educational time on installing and updating, (ii) the conditions for a more differentiated approach to learning are created, and (iii) provides the opportunity to focus on the basic material study 5.

The necessity to use SCM in the educational process is also caused by the fact that working with them provides students with the real opportunity to acquire skills to solve practical problems using SCM on the known scheme: setting of the problem → defining modeling goals → mathematical model development → election of mathematical method and algorithm of problem solution → implementation of mathematical model using SCM → calculations → analysis of the results obtained and their interpretation → making the decision.

A large number of practical problems are studied within the discipline "Operations research", which are easy to interpret as optimization problems on graphs. The examples of such tasks are (i) searching for the shortest route between two settlements, (ii) determination of the maximal admission characteristics of the oil pipeline, and (iii) scheduling the execution of the project works etc.

When solving optimization problems on graphs the interdisciplinary relationships of informatics, mathematics, economics and other disciplines are realized that contributes to the intellectual development of students on the basis of forming ideas about the integrity of vision of the world, ensures the formation of skills not only declarative but also procedural knowledge. The use of graph theory for the problems solution by students develops their ability to represent the conditions of the problem in the lan-

guage of graph theory, and then to interpret the solution in terms of the original problem.

The possibilities of using Maxima system to solve optimization problems on graphs are wide enough. A student, using SCM Maxima, solves the problem set before him, and thus he doesn't have the psychological barrier in the application of mathematical apparatus, and besides, he realizes also, what material is necessary to be repeated (or to be learnt). The solution of problems of applied nature (including, in particular, optimization problems on graphs) using a SCM provides the possibility of formation of the professional competencies. The interest is also the research of optimization theory problems, in particular the implementation of the numerical methods, both conditional and unconditional optimization using SCM Maxima. This, in turn, contributes to the improvement of programming skills.

Studying the section "Models of the dynamic programming" students are offered to solve the problems which demand using Maxima commands and functions or creating their own procedures and functions. This in turn contributes to the improvement of programming skills. For example, when solving the problem of dynamic programming about a backpack, students perform research, creative work, and its routine is completed using the computer.

The main stages of the solution of such problems are the problem setting (providing the objective function, optimality criterion, limitations, and accuracy of the solution) and analysis of the obtained results. The students obtain the system basis in solving problems, and they see the relationship between the content of various academic disciplines.

Summarizing the consideration of the course "Operations research", it should be noted that a wide set of tools for computer support of analytical, computing and graphical operations make the system of computer mathematics one of the main tools in the professional activities of mathematicians and programmers. The studies using Maxima system combine algebraic and computing methods. In this sense, SCM is the combining link between mathematics and computer science, where the research focus both on the development of algorithms for symbolic computation and data processing and the creation of the programs to implement these algorithms.

## **2.2 The characteristics of the Maxima system both in local and cloud-based version.**

The Maxima system works on all modern versions of operating systems Linux and UNIX, Windows 9x/2000/XP" [4, p. 140]. In particular, the cloud-based version of the Maxima system was implemented in the Drohobych Ivan Franko State Pedagogical University. It was installed on a virtual server with operating system Ubuntu 10.04 (Lucid Lynx). In the repository of this operating system, there is a version of the Maxima system based on Emacs editor that was installed on the virtual student's desktop 4, 5.

Besides, all the basic steps with this software product can be performed also in the environment with a graphical interface wxMaxima based on wxWidgets under Windows operating system 4, 5.

Among the mathematical packages the Maxima system owns wide enough possibilities at the implementation of symbol calculations. It is, in fact, the only one of freely distributed open systems, that does not yield the commercial SCM Mathematica and Maple. Maxima system is distributed under the license of GPL and is available to users of operating systems Linux and Windows 4 , p. 139].

### **2.2.1 Using the Maxima system under OS Windows**

Maxima system works on all modern versions of operating systems Linux and Unix, Windows 9x/2000/XP. Consider the work with Maxima system with graphic interface wxMaxima GUI, based on wxWidgets, under Windows operating system 4, p. 140].

### **2.2.2 Using the Maxima system under OS LINUX**

Working with the Maxima system in OS Linux may occur in different ways. Working with remote desktop based on OS Ulteo (a Linux distribution created on the base of Ubuntu), it is convenient to use the texmacs environment, which is installed as a static application on the OS 4, 5. OS Ulteo can be installed on one of the computers of a local network, on a virtual machine created on VMW products, on a virtual machine in OS AWS or some other similar network systems. The experience of using the Maxima system, which was installed on the cloud server, is more thoroughly described in 5.

Texmacs includes the work with several systems, one of which is the Maxima system. To create a session (i.e. insert object) in Maxima one must consistently choose the menu Insert – Session – Maxima. Then an active line appears for entering commands of the Maxima system.

More thoroughly experience of using SCM Maxima in the cloud-oriented environment is described in the "Methodical recommendations on the use of the cloud-oriented component based on the Maxima system in the informatics disciplines studies" 5.

The purpose of using SCM in the process of operations research learning is the fundamentalization of training and mastering the fundamental principles of the discipline. Here is the example of the laboratory practicum on "Construction of the frame of minimum cost, Prim algorithm" using the methods of appropriately selected tasks and demonstration examples that are solved using the cloud-oriented component of the learning environment on the basis of the Maxima system. This task can be carried out also using the local version, so the course of the solution is accompanied by illustrations, which can be obtained in any of the versions of the system, and by the interfaces obtained during the cloud component implementation.

After introducing the main theoretical positions on the subject and Prim algorithm students are offered the following example 10, 11.

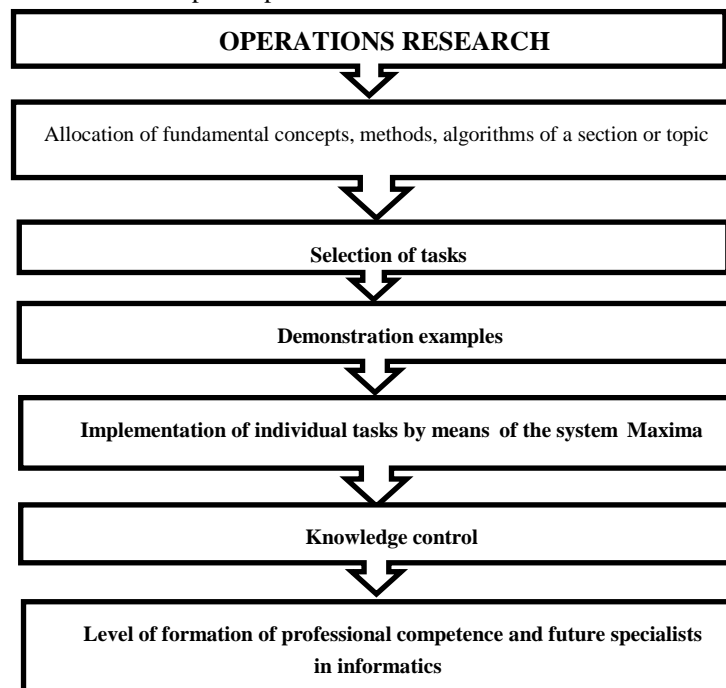
At the end of each laboratory work they are offered the tasks for independent work.

Individual tasks are divided into three levels of complexity. The level of complexity of the assignment for execution is selected by the student independently. The task of the first level of complexity corresponds to the reproductive level of mastering

knowledge. To solve problems of the second level of complexity, the heuristic nature of the intellectual activity is necessary. The third level of complexity includes tasks for which a creative approach is necessary. The tasks are formulated in such a way that to solve them one must have elements of divergent thinking. Divergent thinking is usually inherent in creative individuals, inclined to create new combinations of those elements, others use only the usual way.

Each laboratory work is accompanied by a list of questions for self-examination and a number of tasks for performing during independent work of students. The main task is to form the practical skills of future specialists to formalize tasks and solve them with the help of SCM tools.

Thus, the method of using SCM Maxima as a means of training the study of the operations of future computer specialists can be summarized as follows.:



**Fig. 1.** Scheme of the stages of designing a computer-oriented environment using the system Maxima

The peculiarity of the developed methodology is the use of a systematic approach to the implementation of SCM in the process of studying operations research and their use to provide interdisciplinary links in the training of future IT specialists.

From the given example it is clear that due to the application of SCM Maxima in the process of “Operations research” teaching there arises the opportunity to carry out the necessary calculations. This gives the students the opportunity to use the greater part of educational time for (i) studying methods of applied problems solution, or even their development, (ii) acquiring the skills of mathematical models construction,

(iii) interpreting and analysing results of computing experiment, which lead to a deeper understanding of fundamental concepts that are studied. The use of SCM Maxima provides the ability (i) to provide adequate educational, methodical and scientific-research activities, (ii) to implement innovations into the educational process, (iii) to realize the interdisciplinary principle, and (iv) to combine independent work with various forms of collective activities.

The main stages of the solution of such problems is the problem setting (definition of the objective function, the optimality criterion, the limitations, the accuracy of the solution) and analysis of the obtained results. The students obtain the system approach basis in solving problems, and they see the relationship of the content of various academic disciplines studies.

Summarizing the consideration of the course "Operations research", it should be noted that a wide set of tools for computer support of analytical, computing and graphical operations make the system of computer mathematics one of the main tools in the professional activities of mathematicians and programmers. The studies using the Maxima system combine algebraic and computing methods. In this sense, SCM is the combining link between mathematics and computer science, where the research focus both on the development of algorithms for symbolic computation and data processing using computer and the creation of the programs to implement these algorithms.

### **2.3 Results of the pedagogical experiment using the Maxima system**

During 2010-2014 the experimental research was being conducted. During the experiment they implemented SCM MAXIMA in the process of "Operations research" teaching concerning the students of the Institute of Physics, Mathematics, Economics and Information Technology of the Drohobych Ivan Franco State Pedagogical University (education and qualification level "Bachelor", area of knowledge – 0403 "System sciences and cybernetics", areas of training – 6.040302 " Informatics"). In the experiment, the specially worked out methodology of "Operations research" teaching using the Maxima system was tested. In the experiment, on his forming stage, 240 students participated. In the experiment they involved both the local version of the system, installed on the student computer desktop and the cloud-based version that was posted on the virtual desktop.

To reveal the students' achievements the special test that included three kinds of tasks was formed. The task 1 is aimed at determining the level of formation of professionally-cognitive component of professional competence, task 2 – on the level of professional-activity component formation and task 3 - on creativity.

The experiment confirmed the research hypothesis concerning the increase of the level of professional competences development in the process of studies according to the worked out methodology. It also showed that by means of cloudy technology students can achieve greater access to the means of research activities (it is possible to attain expansion of access to research activity facilities).

Results formative stage of the pedagogical experiment in the control and experimental groups and comparative histogram distribution educational achievements stu-

dents on the results the final exam discipline "Operations Research" is shown in Fig. 2.

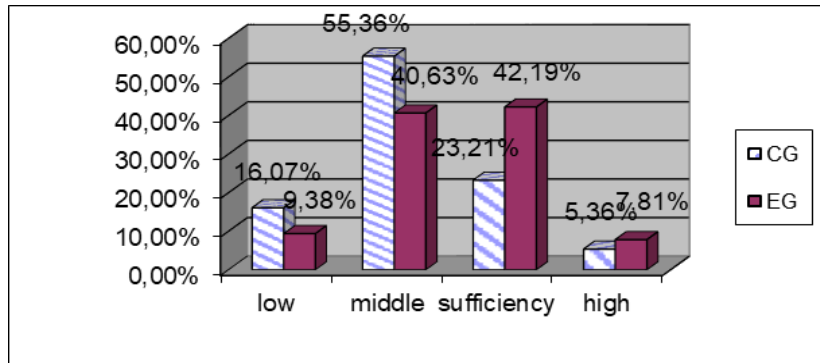


Fig. 2. A comparison of educational achievements of students on the results of final control the course "Operations Research" after the forming stage of the experiment

Processing of the experiment results and evaluation of the efficiency of the developed technique was carried out by methods of mathematical statistics 9. The objective of the experiment was to identify differences in the distribution of certain characteristic (the level of formedness of individual components of professional competence) comparing two empirical distributions according to the  $\chi^2$  - Pearson criterion,  $\lambda$  - Kolmogorov-Smirnov criterion 9, p. 4].

**$\chi^2$  - Pearson criterion.** The samples in the study are random and independent. The measurement scale is  $C = 7$  categories (1-39, 40-59, 60-66, 67-74, 75-81, 82-89, 90-100). The number of the degree of freedom  $\nu = C - 2 = 5$ .

The null hypothesis  $H_0$ : the distribution of the estimates for the student residual knowledges concerning the use of systems of computer mathematics in the control ( $n_1 = 56$ ) and experimental samples ( $n_2 = 64$ ) to the forming stage of the experiment do not differ ( $i = 0, 1, \dots, 6$ ).

$Q_{1i}$  – number of participants in the control group who scored  $i$  points;

$Q_{2i}$  – number of participants in the experimental group who scored  $i$  points.

Alternative hypothesis  $H_1$ : the distribution of the estimates for the student residual knowledges concerning the use of systems of computer mathematics in the control ( $n_1 = 56$ ) and experimental samples ( $n_2 = 64$ ) to the forming stage of the experiment differ ( $i = 0, 1, \dots, 6$ ). The value of  $\chi^2$  is calculated according to the formula

$$T_{\text{exp}} = \frac{1}{n_1 n_2} \sum_{i=0}^{C-1} \frac{(n_1 Q_{2i} - n_2 Q_{1i})^2}{Q_{1i} + Q_{2i}}$$

Since the obtained value  $T_{\text{exp}} < T_{\text{critical}}$  ( $2,372723 < 11,07$ ) does not fall in the critical region  $[\chi^2, +\infty)$ , this suggests that before the forming stage of the experiment the

level of students' residual knowledge concerning SCM using in the control and experimental groups do not differ significantly.

The level of students knowledge on the course "Operations research" as well as professional disciplines was checked according to the results of complex state examination to justify the influence of methodology of SCM using as "Operations research" teaching tools on the increase in the level of some components of professional competence.

Null hypothesis  $H_0$ : distribution of students estimations on "Operations research" in the control ( $n_1 = 56$ ) and experimental samples ( $n_2 = 64$ ) after the formative forming stage of the experiment do not differ ( $i = 0, 1, \dots, 6$ ).

$Q_{1i}$  – number of participants in the control group who scored  $i$  points;

$Q_{2i}$  – number of participants in the experimental group who scored  $i$  points.

Alternative hypothesis  $H_1$ : distribution of students estimations on "Operations research" in the control ( $n_1 = 56$ ) and experimental samples ( $n_2 = 64$ ) after the formative forming stage of the experiment differ ( $i = 0, 1, \dots, 6$ ).

The calculation of  $\chi^2$  criterion for the experimental and control samples after conducting the formative stage of the experiment showed that  $T_{exp} > T_{critical}$  ( $30,20408 > 11,07$ ). This is the reason for rejecting the null hypothesis.

The acceptance of the alternative hypothesis suggests that these samples have statistically significant differences, i.e., the experimental method is more effective than the traditional one.

Taking into account that in the experimental groups the training of students was performed according to the developed methodology, it can be assumed that this contributed to the achievement of better results. Therefore, it is possible to speak of experimental confirmation of the hypotheses.

Summarizing, we conclude that the pedagogical experiment confirmed the hypothesis of the study. Analysis of the results indicates the increase in the level of formation of individual components of professional competence using the developed methodical system and, consequently, its effectiveness.

### **3 Conclusions and Prospects for Further Work**

SCM implementation in the process of training of pre-service professionals in computer science provides an opportunity to intensify the educational-cognitive activity of students, assists to development of their creative abilities, mathematical intuition and skills of research activities realization. SCM systematic using contributes to students attitude toward a computer as to the means of solving professional problems. Such students gain more knowledge not only in mathematical disciplines but also in computer science. As a rule, they have no psychological barrier to using sophisticated software tools. On the contrary, they are attracted by the programs created at a high professional level, and they notice the unique application possibilities of such systems. SCM is an environment for learning tools projecting and, consequently, can be used for the creation of innovative pedagogical technologies. The perspective direc-



tion is using the tools of this type "in the cloud" when there are more possibilities of adaptation of the learning environment to the learning needs of the user.

The prospect of further research is to expand the range of research tasks that can be solved using the proposed cloud-based component, further testing and comparison with other cloud-centric software products on the basis of the certain system of indicators.

## References

1. Kobylnyk, T.P.: Systems of computer mathematics: Maple, Mathematica, Maxima. Drohobych: Redaktsiino-vydavnychiy viddil DDPU imeni Ivana Franka, 316. (2008). (in Ukrainian)
2. Slovak, K.I., Semerikov, S.O., Tryus, Yu.V.: Mobile mathematical environment: current state and development prospects. In: J. NaukovyiChasopys M.P. Dragomanov NP, series 2 "Computer Oriented Learning Systems", vol. 19, № 12, 102-109 (2012). (in Ukrainian)
3. Tryus, Yu.V.: Computer-oriented methodological training system of mathematical disciplines in higher education: dys. ... dokt. ped. nauk : spets. 13.00.02. Cherkasy, 649 p. (2005). (in Ukrainian)
4. Shyshkina, M.P., Kohut, U.P., Bezverbnny, I.A.: Formation of Professional Competence of Computer Science Bachelors in the Cloud Based Environment of the Pedagogical University. In: J. Problems of Modern Teacher Preparation, vol. 9, part 2, 136–146 (2014). (in Ukrainian)
5. Shyshkina, M.P., Kohut, U.P.: Guidelines on the use of the cloud-based component with the Maxima system in the process of computer science courses learning. Drohobych : Red.-vyd. viddil DDPU im. I. Franka, 57, (2014). (in Ukrainian)
6. Bykov, V.: Cloud Computing Technologies, ICT Outsourcing, and New Functions of ICT Departments of Educational and Research Institutions. In: Information Technologies in Education, 10, 8-23, (2011). (in Ukrainian).
7. Tryus, Yu.V.: Using WEB-SCM in optimization and operations research methods training of students of mathematics and computer science disciplines". In: Innovative computer technologies in higher education : materials of the 4th scientific and pracyical conference, Lviv, 110-115. (2012). (in Ukrainian)
8. Buhaiets, N.O.: Modeling of animation visualization by means of graphical environment tools of the program Maxima. In: J. Information Technologies and Learning Tools, vol. 47, № 3, 67-79. <http://journal.iitta.gov.ua>. (2015).
9. Sidorenko, Ye.V.: Methods of mathematical processing in psychology. SPb.: Rech, 350, (2003) (in Ukrainian).
10. Shyshkina, M.P., Kohut, U.P., Popel M.V.: The Systems of Computer Mathematics in the Cloud Based Learning Environment of Educational Institutions. In: Batsakis, S. et al. (eds.) Proc. 13-th Int. Conf. ICTERI 2017, Kyiv, Ukraine, May 15-18, 2017, 396– 405, CEUR-WS.org/ Vol-1844, ISSN 1613–0073, 396–405, online CEUR-WS.org/ Vol-1844. urn:nbn:de:0074-1844-4 (2017).
11. Shyshkina, M.P., Kohut, U.P.: Using the cloud-based component based on the Maxima system in the learning process of operations. In: J. Information Technologies and Learning Tools, vol. 57, № 1, 154-172. <http://journal.iitta.gov.ua>. (2017). (in Ukrainian).

# The Comparative Analysis of the Cloud-based Learning Components Delivering Access to Mathematical Software

Mariya Shyshkina<sup>1</sup>[0000-0001-5569-2700], Uliana Kohut<sup>2</sup>[0000-0002-2861-2274],  
Maiia Popel<sup>1</sup>[0000-0002-8087-962X]

<sup>1</sup>Institute of Information Technologies and Learning Tools of NAES of Ukraine,  
9 M. Berlynskoho St., Kyiv, Ukraine  
{shyshkina, popel}@iitlt.gov.ua

<sup>2</sup>Drohobych Ivan Franko State Pedagogical University, 24 I. Franko Str., Drohobych, Ukraine  
ulyana\_kogut@mail.ru

**Abstract.** In the article, the problems of the systems of computer mathematics use as a tool for the students learning and research activities support are investigated. The promising ways of providing access to the mathematical software in the university learning and research environment are considered. The special aspects of pedagogical applications of these systems to support mathematics and computer science disciplines study in a pedagogical university are considered. The design and evaluation of the cloud-based learning components with the use of the systems of computer mathematics (on the example of the Maxima system and CoCalc) as enmeshing the investigative approach to and increasing pedagogical outcomes is justified. The set of psychological and pedagogical and also technological criteria of evaluation is used to compare different approaches to the environment design. The results of pedagogical experiment are provided. The analysis and evaluation of existing experience of mathematical software use both in SaaS and IaaS cloud-based settings is proposed.

**Keywords:** Cloud computing, systems of computer mathematics, learning tools, mathematical disciplines, learning environment, pedagogical university.

## 1 Introduction

### 1.1 Research objectives

In the modern information-educational environment there are new models of learning and research activity organization that are based on innovative technological solutions. The question of this environment facilities and services organization to enhance the pedagogical effect of modern ICT use comes to the fore. To attain the increase of learning outcomes and also the improvement of the students' research activity the innovative educational approaches are in demand.

A separate set of problems concerns to the application of software packages for the implementation of various mathematical operations, actions and calculations, these are the so-called Systems of Computer Mathematics (SCM), including Maple Net,

MATLAB web-server, WebMathematica, Calculation Laboratory, CoCalc and others [12, 14]. These systems are the most common types of mathematical software, being a part of the modern learning environment of educational institutions [4, 5, 7, 8]. The problems emerge when searching for promising methods and models of these systems use to enhance the pedagogical outcomes and provide the investigative approach to learning of engineering and mathematics disciplines.

**The aim of the article** is the justification of the cloud-based learning components design with the use of the systems of computer mathematics (on the example of the Maxima system and CoCalc) as enhancing the investigative approach to learning and pedagogical outcomes.

## 1.2 The Problem Statement

Nowadays, SCM make a significant impact on the content and forms of learning mathematics and informatics disciplines in higher educational institutions.

A separate set of problems relates to the use of mathematical software tools to enhance the investigative approach to learning. There are two factors in this respect that may significantly influence the investigative activity of students. Firstly SCM bring the possibility to address the basic notions of mathematics on the research level. Due to this the concepts of soft computation, discrete mathematics and others that are mainly computer oriented are included in the learning content. Secondly, SCM being the tool for computer modelling as the general method of investigation that is the fundamental base of all mathematics and computer science disciplines become the instrument of research.

There is a significant demand in the expansion of access to research activities tools while learning informatics and mathematics disciplines in educational universities as well as modernization of the learning environment with the use of current ICT tools, especially the cloud-based ones.

The progress in the area has provided new insights into the problems of educational learning environment development, bringing new models and approaches. These tools make a great impact on the learning data processing changing the content, methods and organizational forms of learning, lifting the restrictions or significantly improving access for all participants [10].

So, the modeling and analysis of the learning components design and deployment and available learning experience of its use in view of the current tendencies of the modern advance of the cloud-based mathematical software has come to the fore.

## 1.3 The Research Methods

The research method involved analyzing the current research (including the domestic, Ukrainian and foreign experience of the cloud-based learning services and mathematical software use in educational institutions in Ukraine and abroad), evaluation of existing approaches to software delivery, their advantages and disadvantages; comparison of promising ways of popular mathematical software implementation "in the cloud", examining the models and approaches, technological solutions and psycholog-

ical and pedagogical assumptions about better ways of introducing innovative technologies into the learning process. The cloud-based component with the use of the Maxima system was designed and elaborated within the study undertaken in 2012-2014 in the Institute of Information Technologies and Learning Tools of NAES of Ukraine devoted to the use of the SCM for the informatics bachelors training (U. Kohut). The learning component for math disciplines study was elaborated within the research undertaken in 2013-2016 (M. Popel). The special indicators to reveal ICT competence of educational personnel trained within the cloud-based learning environment and also the learning components quality evaluation indicators were elaborated within the research work devoted to the university cloud-based learning and research environment formation and development held in 2012-2014 in the Institute of Information Technologies and Learning Tools of NAES of Ukraine (M. Shyshkina). To measure the efficiency of the proposed approach the pedagogical experiment was undertaken in Drohobych Ivan Franko State Pedagogical University. The expert quality evaluation of the cloud-based components elaborated in the study was implemented. The approach and methodology were grounded within the research work "Methodology of the cloud-based learning environment of educational institution formation" that was held in the Institute of Information Technologies and Learning Tools of NAES of Ukraine in 2015-2017, Registration number 0115U002231 (coordinated by M. Shyshkina).

## **2 The State of the Art**

The analysis of the domestic (Ukrainian) and international experience of ICT use of in the process of informatics disciplines learning testifies that such class of ICT-based learning tools as the systems of computer mathematics (SCM) constantly attracts an attention of researchers [4, 5, 8]. These systems, that are complex, multifunctional, powerful enough and at the same time simple in the use, become irreplaceable in maintenance of various processes of numerical accounts, patterns visualization, realization of symbol operations, algorithms and procedures [7, 8]. SCM is the environment for design and use of learning tools and components for informatics and mathematics disciplines, forming innovative pedagogical technologies.

In the recent years, the mathematics and informatics disciplines learning tools and technologies have been actively developed with the use of the cloud computing approach [4, 8]. This conception significantly changes the existing views on the organization of access and integration of applications, so there is a possibility to manage larger ICT infrastructures that allow to create and use both individual and collective "clouds" in a cloud-oriented educational space [1, 7].

Localization of such tools as SCM "in the cloud" is the perspective trend of their development when there are more possibilities for adapting the learning environment to educational demands, individual needs and goals of the learners. There is expansion of a "spectrum" of research activities due to both fundamentalization of informatics disciplines teaching content and expansion of access to research activities tools. In this regard, there is a need to consider the issues of theoretical and methodical

grounding of the SCM-based learning components design, revealing advantages and disadvantages of different approaches to their deployment and implementation.

The use of CoCalc cloud service in the learning process is possible by SaaS model, as this software is provided in such mode. The method of its use for several math disciplines study is considered in [3].

The Maxima system is provided in the local version. The cloud-based learning component with the use of this system was elaborated specially for the needs of learning several informatics disciplines, in particular, operations research study [8, 9].

The use of SCM Maxima in the process of operations research study aims at the forming of students' ICT-competences due to: the acquaintance with functional characteristics of SCM Maxima; developing skills of mathematical research of the applied tasks, in particular, the construction of mathematical models; mastering programming in the SCM Maxima environment; obtaining the necessary knowledge base for studying other math and informatics disciplines; increasing the level of informatics acquirement by means of the extensive use of SCM and cloud-based systems in the educational process and research work.

Methodical peculiarities of teaching optimization methods and operations research using WEB-SCM are analyzed in the work of Trius Y. V. [6]. The graphical interface of SCM Maxima for modelling animations is described in detail in the work of Bugaets N. O. and examples of creating the animation evident models and their use for development of educational-research abilities are given [2]. The problems of the right choice of SCM to support learning and research activity and elaboration of the most advisable methods of its use for math and computer science discipline so as to enhance the investigative activity of the students remain crucial in the area.

The Maxima system is provided in the local version still there is a way to install this system for the virtual desktop of the students using the IaaS cloud service model. Another way for the learning environment design may be realized with the CoCalc system which is provided by SaaS model [3]. The comparison and justification of two different approaches to learning components design need special attention.

### **3 The Research Results**

The choice of SCM to support the investigative approach to learning depends on the input data and results to be obtained. For example, the analytical model of the investigated phenomenon or object is more interesting for a physicist-theorist, so it is better to use the packages such as Mathematica, Maple and Maxima. Physicists-experimenters would rather use the MATLAB system for large data sets processing [8, p. 138].

Special attention should be paid to Maxima system, as it is easy in learning, in solving the problems does not yield to such systems as Maple and Mathematica and is freely distributable. It is equipped with a menu system that allows perform symbol conversions, solve equations, compute limits, derivatives, integrals and the like, without mastering the language for the description of the commands to perform these actions. Therefore, Maxima system can be used for informatics and mathematics disci-

plines learning even in the first course of the educational university [8]. Maxima system introduction will not cause any difficulties for students in solving tasks of mathematical analysis and linear algebra – the students are required only to select a menu item and enter the expression. However, for programming in Maxima system, one needs knowledge of language and syntax, as well as certain commands [8, p.138].

The use of the cloud-based tools of SCM design is a significant factor in the expansion of access to them in the process of teaching and research activities in the field of informatics and mathematics. If research activity was provided only in specially created situations in the case of application of a local version of the tool, in case of the cloud-based version more attention can be paid to the independent work, and research activity is extended outside the classroom time [8].

For this purpose the technology of "virtual desktop" was applied, where the data storage and processing were maintained in the data center. Also, for a user, the work with cloud applications, appealed via the Internet browser, does not differ from the work with software installed on a desktop of the user's personal computer [8].

The use of software that is installed on the student's virtual desktop (I) does not require spending learning time on installing and updating, (II) the conditions for more differentiated approach to learning are created, and (III) provides the opportunity to focus on the basics of the teaching material [8].

The necessity to use SCM in the educational process is also caused by the fact that working with them provides students with the real opportunity to acquire skills to solve practical problems using the conventional scheme: setting of the problem → defining modeling goals → mathematical model development → election of mathematical method and algorithm of problem solution → implementation of mathematical model using SCM → calculations → analysis of the results obtained and their interpretation → making the decision.

A large number of practical problems are studied within the discipline "Operations research", which are easy to interpret as optimization problems on graphs. The examples of such tasks are (I) searching for the shortest route between two settlements, (II) determination of the maximal admission characteristics of the oil pipeline, and (III) scheduling the execution of the project works etc.

When solving optimization problems on graphs the interdisciplinary relationships of informatics, mathematics, economics and other disciplines are realized that contributes to the intellectual development of students on the basis of forming ideas about the integrity of vision of the world, ensures the formation of skills and not only declarative but also procedural knowledge. The graph theory problems solution develops the students ability to represent the problem in the graph theory language, and then to interpret the solution in terms of the original problem.

Summarizing the consideration of the course "Operations research", it should be noted that a wide set of tools for computer support of analytical, computing and graphical operations make the system of computer mathematics to be one of the main tools in the professional activities of mathematicians and programmers. The studies using Maxima system combine algebraic and computing methods. In this sense, SCM is the combining link between mathematics and computer science, where the research focus both on the development of algorithms for symbolic computation and data pro-

cessing using computer and the creation of the programs to implement these algorithms.

### **3.1 The Results of the Pedagogical Experiment of Using Maxima for Learning Mathematics and Informatics Disciplines in Pedagogical University**

During 2010-2014 the experimental research was being conducted. During the experiment, SCM MAXIMA was implemented in the process of operations research teaching concerning the students of the Institute of Physics, Mathematics, Economics and Information Technology of the Drohobych Ivan Franco State Pedagogical University (education and qualification level "Bachelor", area of knowledge – 0403 "System sciences and cybernetics", areas of training – 6.040302 " Informatics"). In the experiment, the specially developed learning method of operations research teaching using Maxima system was tested. At the formative stage of the experiment, there was 240 students participated. The experiment confirmed the research hypothesis concerning the increase of the level of professional competences development in the process of study due to the use of the proposed learning technique [8, 10]. It was also showed that by means of the cloud technology the students can get better access to the research activity tools and facilities.

The special aspect of the study was the learning method application using the cloud version of the Maxima system that was posted on a virtual desktop. In the first case study (with the local version), this tool was applied only in special training situations. In the second case study (the cloud version) the students' research activity with the system extended beyond the classroom time.

The cloud-based learning component used in the experiment has undergone a quality estimation. The method of learning resources quality estimation developed in the joint laboratory of educational quality management with the use of ICT [7] was used and adapted for this study. The 20 experts were specially selected as having experience in teaching professional disciplines focused on the use of ICT and being involved in the evaluation process. The experts evaluated the electronic resource by two groups of parameters. The first group contained 7 technological parameters: ease of access; clarity of the interface; sustainability; support of collaborative work, ease of integration; mobility; and usefulness. The second group contained 9 psychological and pedagogical parameters: the scientific clarity; accessibility; fostering the intellectual development; problem orientation; personalization; adaptability; methodical usefulness; professional orientation; and feedback connection. The results of the quality parameters valorisation and the experts' concordance research are described in [9].

The problem was: is it reasonable and feasible to arrange the environment in a proposed way? For this purpose, there were two questionnaires proposed to an expert concerning two groups of parameters. The 20 experts estimated 16 parameters (there were 7 technological and 9 psychological and pedagogical among them). A four-point scale (0 (no), 1 (low), 2 (good), 3 (excellent)) was used for the questions.

The resulting average value was calculated for every parameter among the technological ones : "Ease of access" = 2.1, "Interface clarity" = 2.4, "Responsiveness" =

2.1, “Sustainability” = 2.56, “Support of Collaborative work” = 2.0, “Ease of Integration” = 2.0, “Usefulness” = 2.8, the total value was 2.3 [9].

The resulting average values for every psychological and pedagogical parameter was calculated as: “Scientific clarity” = 2.6, “Accessibility” = 2.7, “Fostering the intellectual development” = 2.5, “Problem orientation” = 2.8, “Personalization” = 2.8, “Adaptability” = 2.6, “Methodical usefulness” = 2.81, “Professional orientation” = 2,75, “Feedback connection” = 2,75. The total value was 2.71 [9].

The resulted average criterion of EER quality  $K=2,59$ . This characterises the resource quality as sufficient for further implementation and use [8, 9].

We can see that the results of the cloud-based component evaluation by the set of technological and also psychological and pedagogical indicators reveal the usefulness of this component to support the investigative approach to learning. The highest scores of the parameters’ values are “Scientific clarity” = 2.6, “Accessibility” = 2.7, “Fostering the intellectual development” = 2.5, “Problem orientation” = 2.8, “Personalization” = 2.8, “Adaptability” = 2.6, “Methodical usefulness” = 2.81, “Professional orientation” = 2,75, “Feedback connection” = 2,75. Just these kinds of indicators are the most important and “responsible” for the investigative activity of the learner. This fact also supports the hypothesis that the introduction of SCM into the learning process in particular within the cloud-based settings really extends the boundaries of the students research activities expanding it into the broader context.

### **3.2 The experimental Results of Using CoCalc for Learning Mathematics Disciplines in Pedagogical University**

The application of cloud services leads to the emergence and development of forms of training organization focused on joint educational activities on the Internet. It is shown that cloud services in the training of pre-service mathematics teachers are expediently used as tools for:

- communication (synchronous – chats, voice and video; asynchronous – mail, forums),
- collaboration (data access, sharing and collaboration with other users),
- storage and processing of data.

The trends for using CoCalc in the training of mathematics teachers-to-be are as follows:

- organization of educational communication;
- support of individual and group forms of organization of educational activities (classroom and extracurricular);
- support of training management;
- providing visibility by constructing different interpretations of mathematical models, visualizing mathematical abstractions, etc.;
- providing accessibility and knowledge using the shared interface for access to environmental objects and reliable open source software;



- increase in time and spatial mobility; the formation of a single learning environment, the content of which develops in the learning process.

The control and experimental groups were formed as follows: the control groups (CG) included the students trained according to the traditional method of mathematics teachers' professional competencies formation; the experimental groups (EG) included students trained according to the author's technique for using CoCalc as a training tool for mathematics teachers' pre-service training.

Summarizing the obtained results of the confirmatory stage of the pedagogical experiment, it can be argued that:

- the vast majority of students and teachers have the opportunity to work with the cloud-based CoCalc service both at universities and at home;
- students in most cases do not use cloud services in the learning process, except for their use as cloud storage;
- students are interested in implementing the CoCalc cloud service in the learning process, but students are not ready for this;
- students at the beginning of the experiment showed a low level of information and technological and subject-pedagogical competencies formation, sufficient mathematical competencies;
- students and teachers use only free software tools (mostly local computer mathematics systems).

The following components of the subject, technological and professional-practical competencies were examined: subject-pedagogical, informational-technological and mathematical competencies. Each component was considered separately, and the values were calculated according to the levels: high, sufficient, average and low. For data analysis, matches (at the initial stage of the experiment) and differences (after the forming stage of the experiment) of the experimental and control group characteristics were determined according to Fisher's criterion. For this purpose, statistical hypotheses were formulated: the absence of differences between the levels of formation of the individual components of the system of professional competencies and the significance of differences between the levels of formation of selected components.

Analyzing the obtained results at the summarising stage of the experiment, it can be concluded that the levels of formation of professional competences of mathematics pre-service teachers in control and experimental groups coincide with the level of significance  $\alpha=0,05$ .

Comparing the levels of the formation of professional competencies in the control and experimental groups at the beginning of the formative stage and at the end of the experiment, one can observe an increase in the proportion of students with high and average levels of professional competence.

The cloud-based learning component with the use of CoCalc has undergone a quality estimation by the same method and the same set of indicators as the Maxima system learning component.

The resulting average value was calculated for every parameter among the technological ones (Fig. 2): "Ease of access" = 2.3, "Interface clarity" = 2.0, "Responsive-

ness” = 2.1, “Sustainability” = 2.3, “Support of Collaborative work” = 2.6, “Ease of Integration” = 2.0, “Usefulness” = 2.6, the total value was 2.27.

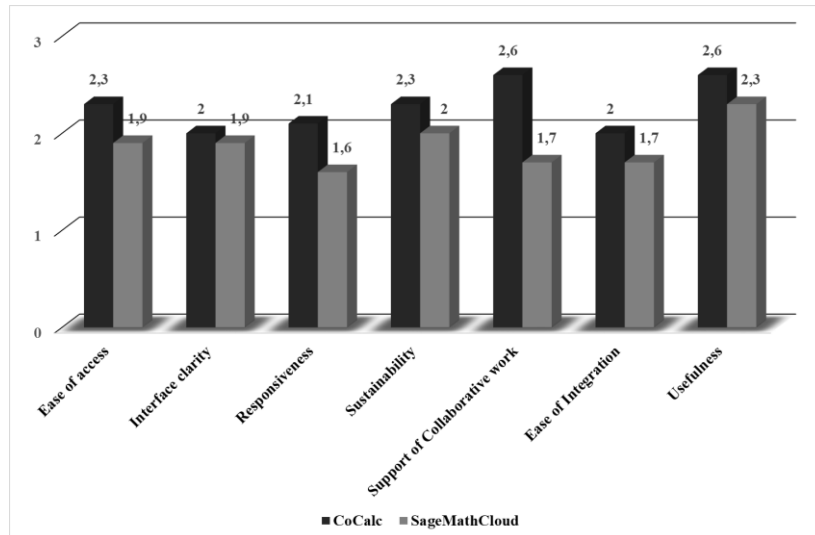


Fig. 1. The average value was calculated for every parameter among the technological indicators for CoCalc

The resulting average values for every psychological and pedagogical parameter was calculated as (Fig. 3): “Scientific clarity” = 2.5, “Accessibility” = 2.4, “Fostering the intellectual development” = 2.4, “Problem orientation” = 2.3, “Personalization” = 2.6, “Adaptability” = 2.4, “Methodical usefulness” = 2.6, “Professional orientation” = 2,5, “Feedback connection” = 2,7. The total value was 2.49 [9].

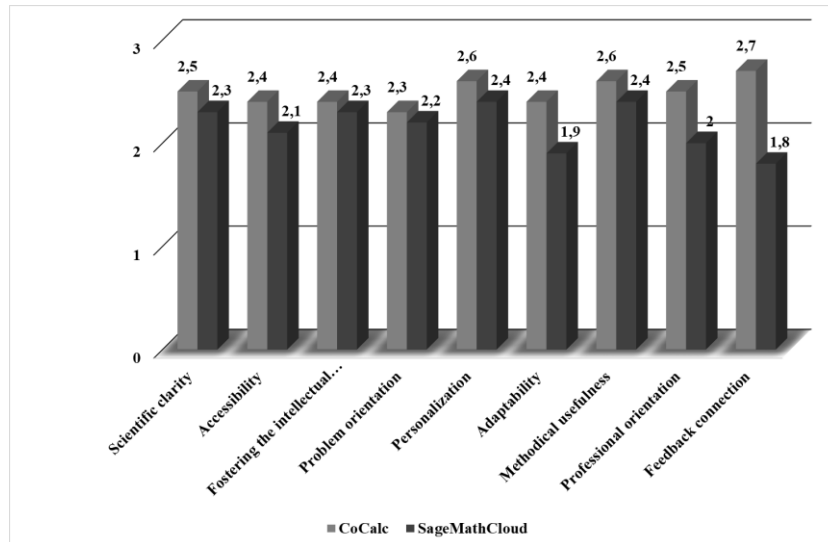


Fig. 2. The average values for every psychological and pedagogical parameter indicators for CoCalc

The resulted average criterion of EER quality  $K=2,38$ . This characterizes the resource quality as sufficient for further implementation and use. It shows that these components don't seem to have quite different differ scores by approach even being implemented for different tasks and disciplines. The CoCalc component still has rather high scores by "Support of Collaborative work" and by "Feedback connection" and "Personalization". This ensures an individual approach to learning with the use of this tool.

#### 4 Conclusions and Discussion

The results of the study indicate certain movement in the development of new ways to create and use the software for educational purposes.

The use of mathematical packages to support the investigative approach to learning involves (I) understanding of the problems of the learning domain for proper use of SCM; (II) understanding the methodology of developing the algorithm from the mathematical statements and formation of the ability to apply this methodology; and (III) the ability to carry out the estimation of the algorithm at run-time and memory requirements. In this case, SCM is to provide the tools for modelling and research of the domain objects in the learning process, to make experiments and approve the results.

The introduction and design of the cloud-based learning components into the process of training contributes to the growth of access to the best examples of electronic resources and services to support the research activities and person-oriented approach within the learning process. The use of these technologies adds and provides an op-

portunity to explore and develop an investigative approach to learning, which in turn leads to the development of new strategies and methodology of teaching of mathematics and computer science disciplines in educational universities. It brings the possibility to expand the investigative activity of students beyond the classroom, to provide the tools for modelling and research of the domain objects in the learning process, widening the spectrum of research activity due to the content fundamentality and interdisciplinary links establishment.

There are the tendencies of more active use of the cloud-based platforms for the software delivery, wider use of services virtualization, as well as their delivery as a service.

## References

1. Bykov, V., Shyshkina, M.: Emerging Technologies for Personnel Training for IT Industry in Ukraine. In: Interactive Collaborative Learning (ICL), 2014 International Conference on, IEEE, pp. 945-949 (2014)
2. Buhaiets, N.O.: Modeling of animation visualization by means of graphical environment tools of the program Maxima In: J. Information Technologies and Learning Tools, vol. 47, № 3, 67-79. <http://journal.iitta.gov.ua>. (2015) (in Ukrainian)
3. Popel, M.V.: The cloud service SageMathCloud as a tool of mathematics teacher professional competencies formation: thesis for a candidat's degree of pedagogical sciences, specialty 13.00.10 – information and communication technologies in education, Kryvyi Rih: KP "Zhovtneva rayonna drukarnya", 23 p. (2017). (in Ukrainian)
4. Slovak, K. I., Semerikov, S. O., Tryus, Yu. V. : Mobile mathematical environment: current state and development prospects. In: J. NaukovyiChasopys M.P. Dragomanov NP, series 2 "Computer Oriented Learning Systems", vol. 19, № 12, 102-109 (2012) (in Ukrainian)
5. Tryus, Yu. V.: Computer-oriented methodological training system of mathematical disciplines in higher education: dys. ... dokt. ped. nauk : spets. 13.00.02. – Cherkasy, 2005. – 649 p. (in Ukrainian)
6. Tryus, Yu. V. : Using WEB-SCM in optimization and operations research methods training of students of mathematics and computer science disciplines. Innovative computer technologies in higher education : materials of the 4th scientific and practical conference, Lviv, 110-115. (2012) (in Ukrainian)
7. Shyshkina, M.P. : The Hybrid Service Model of Electronic Resources Access in the Cloud-Based Learning Environment. In: CEUR Workshop Proceedings, vol.1356, pp.295-310, (2015).
8. Shyshkina, M.P., Kohut, U.P., Bezverbnyy, I.A.: Formation of Professional Competence of Computer Science Bachelors in the Cloud Based Environment of the Pedagogical University. In: J. Problems of Modern Teacher Preparation, vol. 9, part 2, 136–146 (2014) (in Ukrainian)
9. Shyshkina, M. : The Hybrid Cloud-based Service Model of Learning Resources Access and its Evaluation. In: CEUR Workshop Proceedings, vol. 1614, pp.241-256, (2016).
10. Shyshkina, M., Kohut, U., Popel M.: The Systems of Computer Mathematics in the Cloud-Based Learning Environment of the Educational Institutions. In: CEUR Workshop Proceedings, vol. 1844, pp. 396-405, (2017).

11. Sidorenko Ye. V. : Methods of mathematical processing in psychology. SPb. : Rech, 350, (2003)
12. Smith, A., Bhogal J., Mak Sharma: Cloud computing: adoption considerations for business and education. 2014 International Conference on Future Internet of Things and Cloud (FiCloud), (2014)
13. Vaquero, L. M.: EduCloud: PaaS versus IaaS cloud usage for an advanced computer science course. In: IEEE Transactions on Education, 54(4), pp.590–598, (2012)
14. Wick, D.: Free and open-source software applications for mathematics and education. In: Proceedings of the twenty-first annual international conference on technology in collegiate mathematics, pp.300–304, (2009)

# Electronic Textbook as a Component of Smart Kids Technology of Education of Elementary School Pupils

Svitlana Lytvynova [0000-0002-5450-6635]

Institute of Information Technologies and Learning Tools  
of National Academy of Educational Sciences of Ukraine,  
9 M. Berlyns'koho st., 04060, Kyiv, Ukraine  
s.h.lytvynova@gmail.com

**Abstract.** The article sets out to analyze national and foreign experience of use of electronic textbooks in the system of education; to justify the use of Smart Kids technology as a system of methods, forms, and electronic educational game resources, electronic textbooks for educational process in the system of elementary school. Four forms of implementation of Smart Kids technology (Smart Case, Smart Teacher, Smart Class, and Smart Kids) were described considering the facilities of every school as well as the level of information and communication technology qualification of the elementary school teacher. The aim of introduction of the technology for each form of teaching, the necessary equipment, and means for its implementation in elementary school environment were determined. Based on the procedural approach to work of an elementary school teacher, six stages of introduction of the technology were justified. Specific aspects of introduction of blended teaching using the principles of Smart Kids technology were defined. The experience of introduction of electronic textbooks to the system of elementary education of Ukraine was described, the choice of electronic textbooks by elementary school teachers was justified, the comments and suggestions of teachers regarding the arrangement of electronic content in E-textbooks were summarized, the main approaches of teachers to the choice of an electronic textbook and development of their information and communication competence were specified. It was identified that the forms, methods, and techniques of use of electronic textbooks in teaching elementary school pupils require further justification.

**Keywords.** Electronic Textbook; Electronic Educational Resources (EER); Electronic Educational Gaming Resources (EEGR), Smart Kids Technology, Elementary School, ICT, Forms of Teaching, Blended Teaching.

## 1 Introduction

The topic of the research is of great relevance due to transition of education to the child-centered, competence building, and activity-based approaches, which is indicated in Conceptual Principles of Secondary School Reform “The New Ukrainian School”. Current demands of society to educational process require its practical orientation, in particular use of modern technologies and provision of conditions for self-

development and self-expression of pupils, considering their individual characteristics.

The legislative basis for introduction of modern technologies to educational process in the secondary educational establishments is represented by the Order of the Cabinet of Ministers of Ukraine “On approval of the Concept of implementation of “The New Ukrainian School” governmental policy in the sphere of reforming of general secondary education for the period till 2029”, the Order of the Cabinet of Ministers of Ukraine “On adoption of the plan of action in introduction of the Concept of implementation of “The New Ukrainian School” governmental policy in the sphere of reforming of general secondary education for the period of 2017 – 2019”, the Order of Ministry of Education and Science, Youth and Sports of Ukraine “On measures in introduction of electronic educational content”, “On adoption of the Provisions on an electronic textbook”.

One of the innovations of elementary school is use of electronic educational resources (EER), namely electronic textbooks (E-textbooks) and electronic educational game resources (EEGR).

As EER we will define educational, scientific, informational, and reference materials and means, developed in electronic format, available on data carriers of any type or on computer networks, rendered via electronic digital technical means, and necessary for efficient organization of educational process, particularly the aspects connected with its provision with the high-quality teaching materials [10].

EER is a component of educational process, having the teaching purpose and being used for learning activities of pupils.

EEGR is a type of electronic educational resource of training purpose which combines cognitive and developing functions, containing holistic theoretical material and competence building tasks on the academic subject, presented in game form [8, p. 133].

E-textbook is an electronic educational edition that comprises systematized training material conforming to the curriculum, involves digital objects of different format, and provides interactivity [9].

In addition to holistic content part, E-textbook contains interactive tasks, namely those competence building; multimedia fragments for illustration of theoretical material, electronic tests for formative assessment, various 3D models, and objects of augmented reality.

Elementary school teachers state that use of E-textbooks and EEGR in elementary school should be carried out due to the technology that considers the age characteristics of pupils, as well as the level of qualification of pupils and teachers in modern educational resources. Scholars note the necessity of development of new models of educational process organization and use of a system of interactive tasks to provide the continuous development of cognitive skills of elementary school pupils and stimulation of their cognition, which requires further investigation.

## **2 Analysis of latest research and publications**

E-textbook is the first step in creating a dynamic model of education based on coop-

eration and networked learning, simultaneously being adaptive for integration with other Internet tools, including free ones, which provides the conditions for collective formation of new knowledge and implementation of a new concept of education according to social challenges [18].

The works by V.Yu. Bykov [1], S.H. Lytvynova [1], [6], [7], [18], O.M. Melnyk [1], [7], [8], O.O. Rybalko [11] reveal the concept of “EER”, specifying the demands to such materials. Gamification aspects intended to enhance the efficiency of teaching pupils at the Mathematics classes in elementary school are investigated by L.O. Zhydilova, K.I. Liashenko, A.L. Stolyarevska [5]. The characteristics and criteria of quality evaluation of E-textbooks are established in the works of foreign scientists [21].

O.H. Yesina and L.M. Lingur theoretically justified that use of electronic textbook in educational process provides development of creative and intuitive thinking; esthetic education by means of graphics and multimedia capacities, development of communicative skills; fostering skills to make an optimal decision [4].

Positive practical results were achieved in defining the characteristics of use of E-textbook for independent work intensification. It was proved that the process of work with E-textbook allows expanding the volume of data and messages submitted, improving the efficiency of extratextual component for self-organization and self-control of academic achievements [13].

Scholars L.L. Bosova and N.E. Zubchenok distinguish positive directions of introduction of E-textbook to educational process, namely additional opportunities for assistance and support of learning activity of every pupil as well as organization and support of group learning activities of pupils [3].

Furthermore, the results suggest two directions in which teachers can use E-textbooks to raise pupils' interest in studying: creation of modern conditions for pupils' work in the classroom and improvement of system of homework preparation [22].

Developing a holistic conceptual vision of an educational edition of a new type, discussing the models of introduction of electronic textbook to common practice, and a range of other crucial aspects are the tasks whose completion largely depend on the work of scientists, practice teachers etc. [14].

Despite a comparative analysis of pupils' choice between printed and E-textbooks, performed by the scholars, no sufficient dependencies in the results of pupils' work or demographic characteristics were established. The simplicity of use of the book was the determining factor of pupils' choice, which should be taken as a basis for development of a modern E-textbook [15; 19].

Some aspects of structure, design, assessment of E-textbook functionality, integration of information and communication technology for the purpose of support of learning were analyzed by scientists from different countries. Nevertheless, some issues of organization of educational process involving E-textbooks were only partially investigated by scholars and thus require additional research [16].

Unresolved aspects of the problem. Despite the experience and results of foreign scientists and certain groundworks on this subject by national scholars, as well as considering novelty of educational processes based on use of textbooks of new type, the questions of developing the models of use of E-textbooks, defining the character-



istics of organization of educational process, and efficiency of involving E-textbooks in teaching pupils of general secondary educational establishments of Ukraine were not completely resolved by researchers, which requires further investigation.

The purpose of this article is to justify the use of Smart Kids technology and electronic textbooks in elementary school educational process.

### **3 Methods of Research**

The research was conducted as part of investigation “Smart Kids technology of teaching elementary school pupils”. The methods used in the course of research include analysis of the theoretical sources, study of the best pedagogical practices of foreign and national specialists in using electronic educational resources and applying them in teaching pupils; synthesis, generalization, and conceptualization to devise the main provisions of the research; modelling the educational process and formulating requirements to electronic textbooks and training of future elementary school teachers; summarization and assessment of results of choice of electronic textbooks by elementary school teachers.

### **4 Research Results**

#### **4.1 Smart Kids technology of education of elementary school pupils**

As K. Hicks states, a methodological subsystem of secondary educational establishments is to be developing constantly. It results from emergence of new technologies in education, namely: introduction of innovations, new approaches to cooperation, cloud technologies, mobile technologies, creation of educational games and gamification of educational process; ubiquitous access to open educational content, monitoring and educational analytics; projecting educational environment [17].

As pedagogical technology we will define a system of methods, forms, and means of conducting any process pertaining to education [2].

*As Smart Kids technology we will define a system of methods, forms, electronic educational game resources and electronic textbooks to provide education of elementary school pupil (Fig. 1).*

*E-textbook and EEGR are the components of Smart Kids technology.*

In general, secondary educational establishments, Smart Kids technology is implemented in the following four forms: Smart Case, Smart Teacher, Smart Class, and Smart Kids. Let us consider them (Fig. 2).

*Smart Case Form.* The aim: use of E-textbooks/EEGR for stimulation of learning activity of pupils in a class. The form of work: teamwork. The necessary equipment: teacher’s briefcase with E-textbooks/EEGR, projector, interactive whiteboard, teacher’s computer.

*Smart Teacher Form.* The aim: use of E-textbooks/EEGR for ubiquitous access of pupils to teaching materials with the help of their own computers (laptops, tablets). The form of work: frontal and individual. The necessary equipment: teacher’s brief-

case with E-textbooks/EEGR, projector, interactive whiteboard, teacher's computer, teacher's virtual office, pupils' home computers. Teacher uses the virtual office as an electronic register of quantity and quality of the tasks performed by students. For the purpose of developing an individual pupil's trajectory, a teacher can coordinate task performance by each pupil.

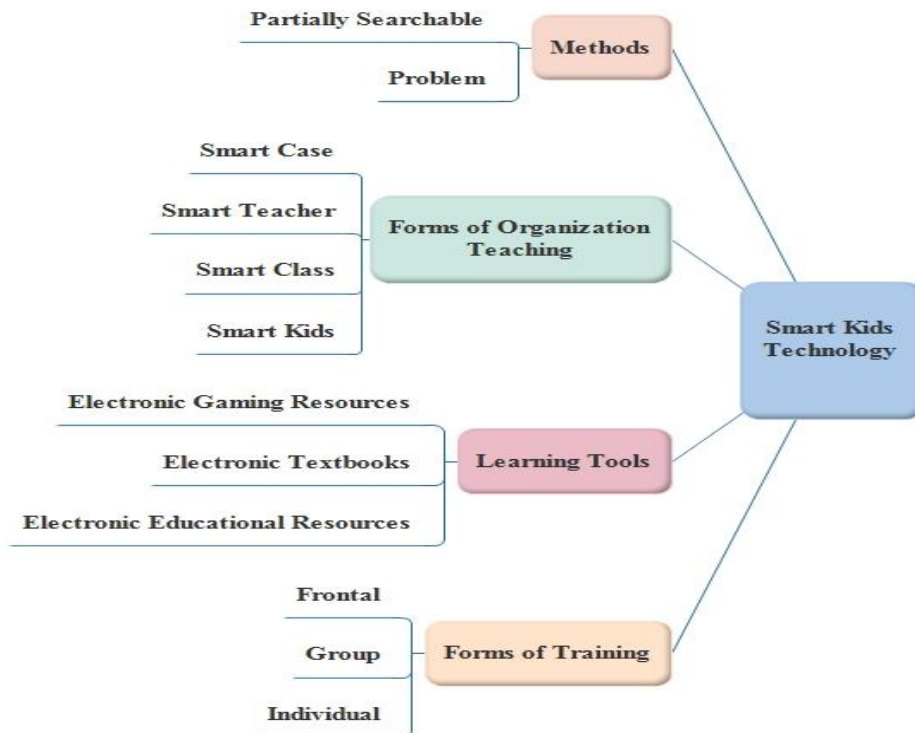


Fig. 1. The Conceptual Structure of Smart Kids Technology

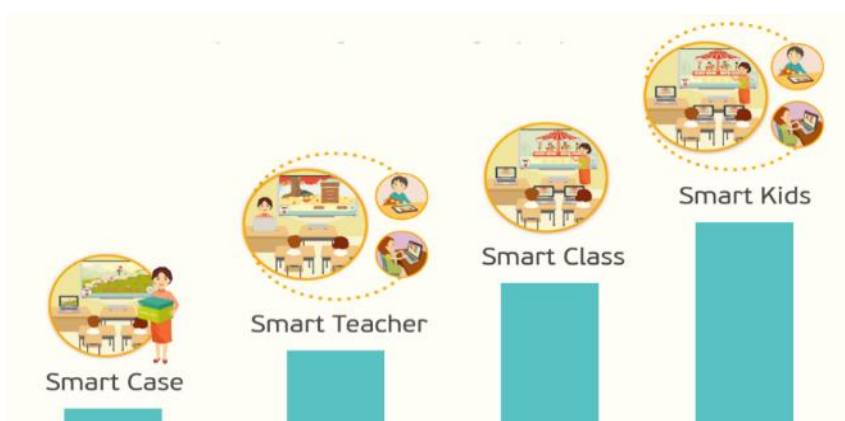


Fig. 2. Forms of implementation of Smart Kids technology in elementary school

*Smart Class Form.* The aim: use of E-textbooks/EEGR for developing an individual pupil's trajectory. The form of work: individual. The necessary equipment: teacher's briefcase with E-textbooks/EEGR, projector, interactive whiteboard, teacher's computer, tablets for each pupil.

*Smart Kids Form.* The aim: use of E-textbooks/EEGR for stimulation of learning activity of pupils in the classroom, provision of the ubiquitous access of pupils to learning materials, and development of an individual pupil's improvement trajectory. The form of work: teamwork, individual, group. The necessary equipment: teacher's briefcase with E-textbooks/EEGR, projector, interactive whiteboard, teacher's computer, tablets for each pupil, teacher's virtual office, pupils' home computers.

Use of E-textbooks should be conducted according to the aim and tasks of a lesson, namely at the beginning, in the middle, at the end of a lesson, or for independent study at home [7, p. 20]. At the beginning of a lesson, a teacher can use E-textbooks/EEGR for refreshing the basic knowledge, checking additional tasks, conducting dictations (mathematical, grammar). For knowledge retention, it's advisable to use E-textbooks in the middle of the class, which will provide the pupils with an opportunity to master the skills in writing or solving problems in game form. At the end of the lesson it is recommended to select the tasks that would allow summarizing the material learned at the lesson.

Methodological characteristics of Smart Kids technology include organization of relay competitions, quests, contests, and crosswords.

To provide a health-preserving approach to studying and comply with the health standards, use of E-textbooks/EEGR at a lesson should not exceed 10-12 minutes.

The main advantages of use of Smart Kids technology include target development of memory, attention, thought, perception of teaching data from the screen, as well as development of culture of use of EEGR and electronic textbooks and competences in educational communication [1], [11], [20].

To introduce Smart Kids technology to elementary school, it's necessary to own E-textbooks/EEGR, while for an elementary school teacher to understand the main stages of introduction of such a technology. Let us consider the stages of introduction of Smart Kids technology to the system of elementary education (Table 1).

**Table 1. Stages of introduction of Smart Kids technology**

<b>Stage</b>	<b>The content of stage</b>	<b>Procedures</b>
Stage 1	Testing one of E-textbooks (or EEGR) during educational process in conditions of elementary school	Mastering skills of integration of EEGR with teaching materials and practical tasks. Use of E-textbooks/EEGR for frontal work with a class. Use of E-textbooks/EEGR in fragmentary mode.
Stage 2	Systematic use of one of E-textbooks (or EEGR) during educational process for frontal work with a class	Building skills of organization of frontal work with pupils (fragmentary mode)
Stage 3	Use of an E-textbook (or	Building skills of organization of group

	EEGR) for learning basic disciplines for group work with a class	work with pupils (fragmentary mode)
Stage 4	Systematic use of an E-textbook (or EEGR) during educational process both for frontal and group work	Organization of efficient frontal and group work with pupils
Stage 5	Systematic use of E-textbooks/EEGR	Establishing pupils' work at home. Introduction of elements of blended teaching
Stage 6	Conscious use of Smart Kids technology for teaching elementary school pupils	Organization of efficient frontal and group work with pupils, blended teaching based on E-textbooks/EEGR

#### **4.2 The aspects of blended teaching of elementary school pupils within Smart Kids technology**

Organization of teaching pupils with the help of E-textbooks/EEGR has the features of blended teaching [13] and can be conducted by two methods.

Method 1. While learning in the classroom, one part of a lesson consists in independent work with computers and educational resources, or an electronic textbook, while the other one – in frontal or group work in copybooks.

Method 2. At home, pupils watch video fragments, get familiarized with new topics, perform independent tasks on computer, while in the classroom summarize, master their skills, and acquire competences.

The organization of performing tasks by pupils has some specific characteristics, in particular:

- independent performing of tasks (in the classroom) using a computer, including tablets, under teacher's supervision, complying with health standards (up to 12 minutes) and corresponding to the topic of a lesson;
- independent performing of tasks (at home) using a computer, a tablet, or a smartphone under parents' supervision;
- watching video materials in the classroom; a teacher selects the necessary fragment and presents it to students. Afterwards, the tasks of the following types are performed: to describe the event; to express opinion on the fragment watched; to provide characteristics of a character; to write a continuation etc.;
- watching video materials at home aimed at revision of the material learned, improving knowledge on the topic learned; creating a picture narration with the purpose of development of imaginative thinking or attention.

### 4.3 The electronic textbooks in elementary school

Organization and introduction of Smart Kids technology to the system of elementary education at schools require both means of information and communication technologies (tablets for individual and group work, multimedia means for frontal work) and electronic educational resources, namely electronic textbooks that can be used by pupils during educational process in the classroom and at home.

The Law of Ukraine “On education”, adopted in September 2017, specifies that the state guarantees free supply of textbooks (including electronic ones) for applicants for complete general secondary education (p. 5, article 75). This presupposes creation and functioning of a special informational resource on the Internet which will host free complete electronic versions of printed textbooks or electronic textbooks to provide pupils with complete general secondary education.

In 2018, due to “Provisions on electronic textbook”, first electronic textbooks for elementary school (1<sup>st</sup> grade) were developed in Ukraine, including: “Ya doslidzhuiv svit” (“I investigate the world”), “Mystetstvo” (“Art”), “Ukrainska mova. Bukvar” (“Ukrainian language. Primer”), “Matematyka” (“Mathematics”) (The Order of the Ministry of Education and Science of Ukraine No. 1078 of 04/10/18 “On assigning the status “Recommended by the Ministry of Education and Science of Ukraine” to electronic textbooks for elementary grades of The New Ukrainian School”).

Three publishers – “Ranok”, “Heneza”, and “Rozumnyky” – took part in development of the textbooks. In selecting the technology of electronic textbook arrangement, “Ranok” and “Rozumnyky” publishers chose the PDF-format of a printed textbook, additionally providing it with a range of interactive exercises, accompanying sounds and developing the navigation similar to that of a traditional one, while “Heneza” publisher followed another approach, creating a textbook by analogy with a computer game.

Organization of the choice of e-textbooks (50 schools of Ukraine taking part in the experiment “Electronic textbook for general secondary education” (EBSE)): e-textbooks were placed in the electronic library; all participants of the experiment had access to them; the choice of e-textbook was recorded in a paper questionnaire and sent for compilation by e-mail. Selection of electronic books by elementary school teachers showed the following results:

- 1) Electronic textbook on integrated course “Ya doslidzhuiv svit” (“I investigate the world”), 1<sup>st</sup> grade (Table 2, Fig. 3).

**Table 2. The results of choice of “Ya doslidzhuiv svit” (“I investigate the world”) E-textbook**

No.	Publisher	Authors	Rating
1	“Rozumnyky Publisher” LLC	Voronstova, T.V., Ponomarenko, V.S., Khomych, O.L., Harbuziuk, I.V., Andruk, N.V, Vasylenko, K.S.	2/31%
2	“Ranok Publisher” LLC	Bibik, N.M., Bondarchuk, H.P.	<b>1/37%</b>
3	“Ranok Publisher” LLC	Bolshakova, I.O., Prystinska, M.S.	3/26%

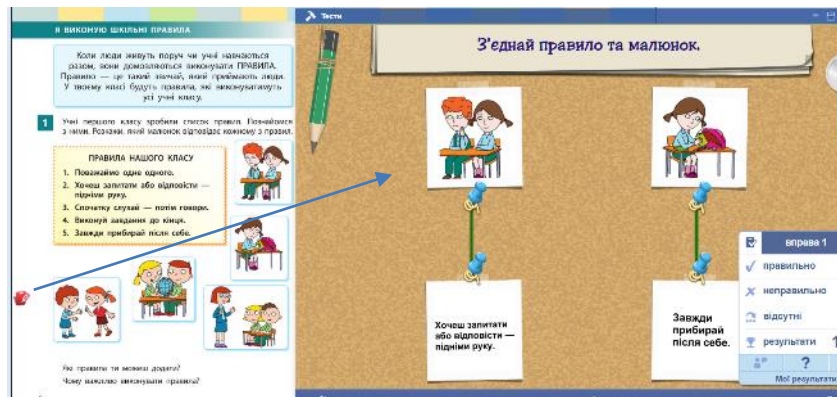


Fig. 3. Interactive exercises of "I investigate the world" E-textbook

2) Electronic textbook on integrated course "Mystetstvo" ("Art"), 1<sup>st</sup> grade (Table 3, Fig. 4).

Table 3. The results of choice of "Mystetstvo" ("Art") E-textbook

No	Publisher	Authors	Rating
1	"Rozumnyky Publisher" LLC	Kalinichenko, O.V., Arystova, L.S.	2/29%
2	"Heneza Publisher" LLC, "Bristar" PE	Masol, L.M., Haidamaka, O.V., Kolotylo, O.M.	1/53%
3	"Ranok Publisher" LLC	Rublia, T.Ye., Shchehlova, T.L., Med, I.L.	3/18%

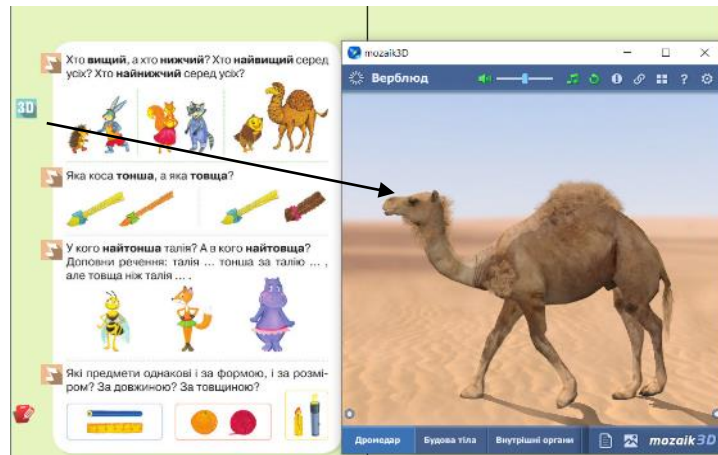


Fig. 4. Interactive exercises of "Art" E-textbook

3) Electronic textbook "Matematyka" ("Mathematics"), 1<sup>st</sup> grade (Table 4, Fig. 5).

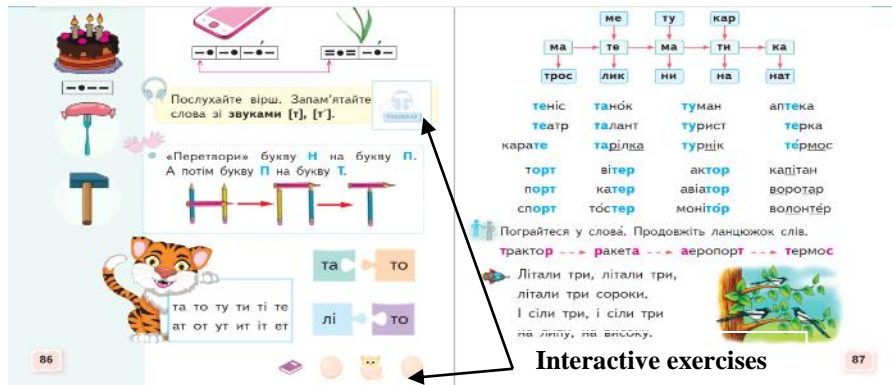
**Table 4. The results of choice of “Matematyka” (“Mathematics”) E-textbook**

No.	Publisher	Authors	Rating
1	“Rozumnyky Publisher” LLC	Bevz, V.H., Vasylieva, D.M.	2/48%
2	“Ranok Publisher” LLC	His, O.M, Filiak, I.V.	1/52%



**Fig. 5. 3D interactive models in “Mathematics” E-textbook**

- 4) Electronic textbook “Ukrainska mova. Bukvar” (“Ukrainian language. Primer”) for 1<sup>st</sup> grade was submitted by one publisher, namely “Rozumnyky Publisher” LLC, the authors: Vashulenko, M.S., Vashulenko, O.V. (Fig. 6).



**Fig. 6. Text voicing and motivation exercises in “Ukrainian language: Primer” E-textbook**

The difference in shares of the selected electronic textbooks among the publishers equaled approximately 6%, yet, it was characteristic of only 2 schools.

After selection of textbooks, a blitz survey was conducted, aimed at defining the approaches to the choice and attitude of elementary school teachers to a textbook of new type. Let us consider the results.

*Question 1* related to work experience of the teachers. The results on work experience of the teachers willing to use first E-textbooks proved to be unexpected. These were not teacher specialists but practice teachers with more than 16 years of work experience (fig. 7).

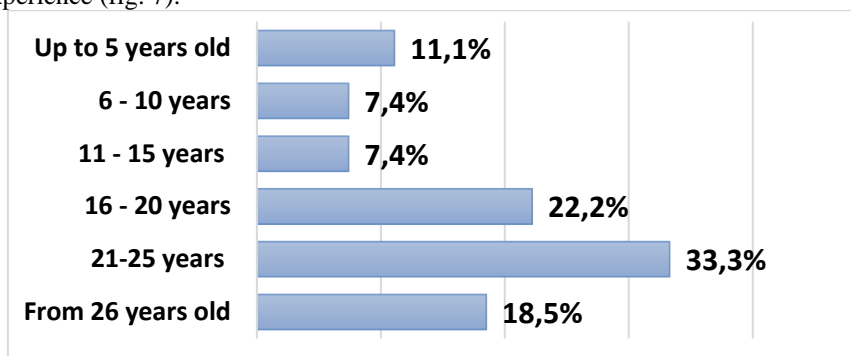


Fig. 7. Work experience of teachers using the first E-textbooks

*Question 2* was connected with approaches to the choice of E-textbooks (fig. 8).

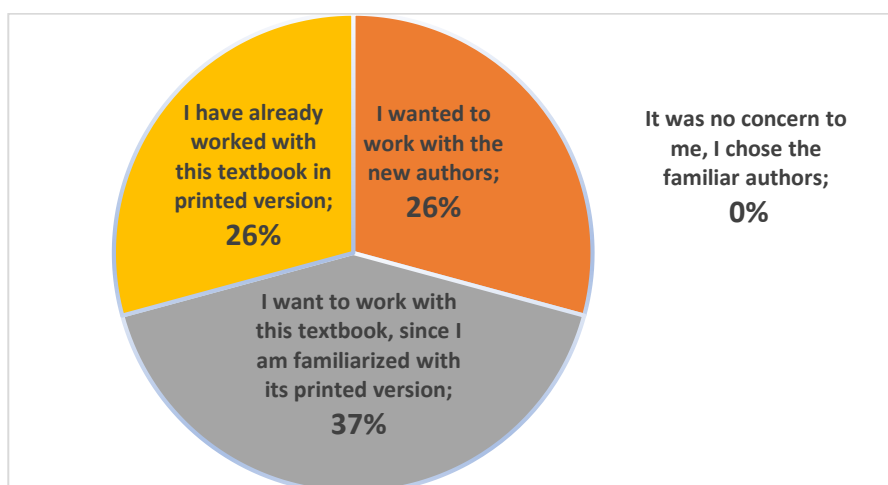


Fig. 8. Approaches to the choice of E-textbooks

As we can see, the majority of teachers – 63% – chose the specific electronic textbook, since they were already familiar with the content of a similar printed textbook, the authors of the textbook, and they had experience of using the printed textbook in educational process.

*Question 3* concerned the positive characteristics of an innovative E-textbook (the process of familiarization) (fig. 9).



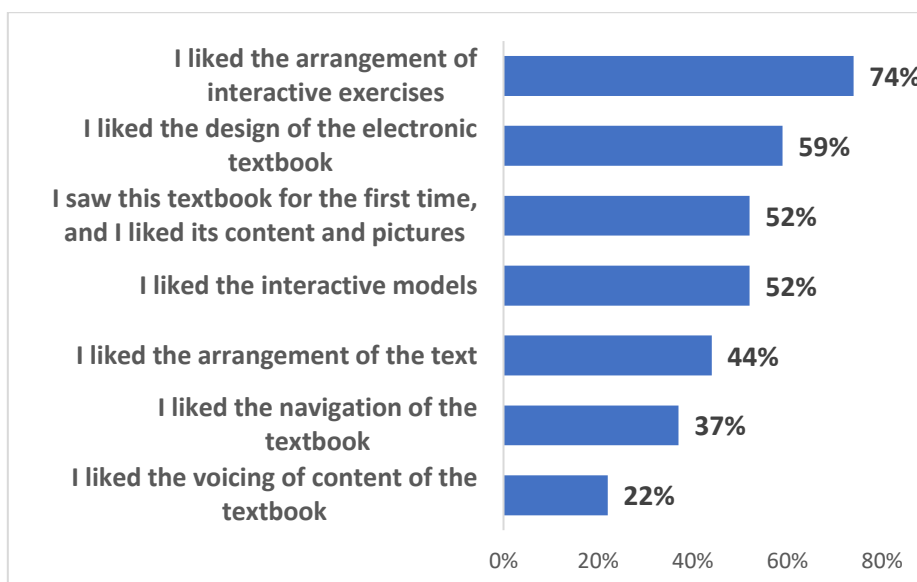


Fig. 9. Positive characteristics of E-textbooks

It would be appropriate to notice that the teachers were satisfied with technologies of arrangement of interactive exercises, content and pictures, the design of E-textbooks, and the interactive models presented.

*Question 4* was dedicated to suggestions of elementary school teachers concerning the content and technologies of representation of E-textbooks. The teachers are of the opinion that it's necessary:

- to increase the number of interactive exercises;
- to enhance the task variability;
- to provide alternation of types of interactive exercises (for diversity at the lessons);
- to add situational exercises, role-play situations, modelling;
- to introduce appendices with the etymology of new words.

In analyzing the answers, it was found that the E-textbook generally satisfies the needs of educational process in elementary school, yet the practice teachers consider it necessary to saturate the E-textbook with interactive exercises (to increase their number) and provide more variability.

Certain comments on the projects of E-textbooks were submitted by The Committee on digital technologies in education with Ministry of Education and Science of Ukraine, in particular:

- cautions on development of electronic textbooks based on paid software;
- certain hyperlinks in E-textbooks were redirecting to resources on YouTube;
- voicing of the text in certain electronic textbooks was partially provided.

All these comments should be considered by publishers in improvement of first electronic textbooks.

Generally, the electronic textbooks presented were highly appreciated by elementary school teachers and, thus, can be used in educational process within elementary education reforming and introduction of pedagogical technologies, namely Smart Kids.

#### 4.4 Examples of implementation of E-textbook in teaching 1st grade students

According to the 1st grade curriculum within the New Ukrainian School reform (Ukraine), interactive exercises should correspond to the content of educational material (the designation of sounds by letters; familiarity with letters denoting consonants; teaching the basic technique of reading a direct syllable with a letter designating a vowel sound, etc.) as well as promote students' learning achievements (recognition and distinguishing between letters to indicate vowels and consonants; reading syllables, etc.).

Fragment of the lesson script for 6 years old students (1st grade) using interactive exercises from an electronic textbook (within not more than 12 minutes per a lesson) is represented below.

1. *Start working with an electronic textbook* (Fig. 10).

Students: pronounce the sound and the letter "D", listen to the text, read straight syllables aloud, and work out the skills of navigation and movement of objects in the electronic textbook.

Learning achievements: students get acquainted with the letter "D", study (memorize) its designations, give examples of words with the letter "D" orally, compare sounds.

2. *Work in groups. Didactic game "Recognize the letter D"* (Fig. 11).

Students: perform interactive exercises in the electronic textbook.

Learning Achievements: Students recognize the letter "D" among other letters and count its number.



Fig. 10. The fragment of refreshing of students' knowledge



Fig. 11. Fragment of the exercise "Recognize the letter "D""

3. *Individual work (students work on tablets). "Puzzles" didactic game* (Fig. 12).

Students: perform interactive mapping exercises posted in an electronic textbook, pronounce sounds and letters.

Learning Achievements: Students distinguish the letter "D" from the list provided and pronounce the sound and the letter.

4. *Frontal work. Reading syllables in direct and reverse manners (Fig. 13).*

Students: learn syllables, pronounce them, move them, complete interactive exercises with an e-textbook.

Learning Achievements: students acquired the skills of the basic techniques of reading direct syllables with the letter “D”, increased the level of IC-competence.



Fig. 12. The fragment of the interactive exercise “Puzzles”



Fig. 13. The fragment of “Syllables” interactive task

5. *Let's do some eyes exercises. Finish working with the electronic textbook.*

## 5 Discussing and suggestions on training elementary school teachers in use of Smart Kids technology

Currently, there emerges a need for training elementary school teachers in use of electronic textbooks or EEGR during a lesson, in organization of pupils' work by means of information and communication technologies after-hours, and in supervision of pupils' independent work.

Hence, introduction of Smart Kids technology to elementary school require improvement of the content and including to the development and training program of elementary school teachers the following topics: the concepts of EER, EEGR, and electronic textbook, the structure and development of EER, use of Smart Kids technology for teaching pupils, work with network programs for organization of questioning of pupils.

*The main directions of building competence* of a future elementary school teacher using Smart Kids technology as a component of professional training include: establishment of learning environment of elementary school; use of multimedia complex for work with a class; teacher's briefcase of electronic educational game resources; forms of implementation of Smart Kids technology; methods of teaching students using smart Kids technology; organization and methodological aspects of lesson planning using E-textbooks (namely, EEGR); teacher's virtual office; monitoring pupils' educational attainment; assessment of a lesson using E-textbook (namely, EEGR); assessment of E-textbooks (namely, EEGR).

These directions of training are to be included in curriculums of higher educational establishments specializing in training of future elementary school teachers.

## 6 Conclusions and recommendations for further research

Use of electronic textbooks (or EEGR) diversify the process of teaching, provides transition from passive to active methods of teaching, stimulates learning and cognition activity, allows to develop individual improvement trajectory for each elementary school pupil [8].

Textbooks of new type – electronic textbooks – become an alternative to a traditional printed textbook. Various interactive exercises, voicing, formative assessment provide an opportunity of exciting learning for each child.

New Smart Kids technology provides target development of memory, attention, thought, perception of teaching data from the computer screen, which is crucial for development of personality of a pupil in the 21st century. Smart Kids technology is a system of active target development of a modern elementary school pupil. As a coordinator of this process, a teacher should master the latest teaching technologies based on ICT. Improvement of the system of training of future elementary school teachers require not only basic knowledge of computer equipment, but that of new approaches to establishment of learning environment using new teaching technologies – Smart Kids.

Modern elementary school teachers should master all modern pedagogical and information and communication technologies for the purpose of providing child-centered, competence building, and activity-based studying, as well as implementation of “The New Ukrainian School” Concept.

Forms, methods, and techniques of use of electronic textbooks in teaching elementary school pupils require further justification.

## References

1. Bykov, V. Yu., Lytvynova, S. H., Melnyk, O. M.: "The effectiveness of learning with the use of electronic educational game resources in primary school", *Informatsiini Tekhnologii I Zasoby Navchannia*, Vol. 62, № 6, Pp. 34-46, [Online]. Available at: <https://journal.iitta.gov.ua/index.php/itlt/article/view/1937/1289>, last accessed 2018/01/07 (2017). (in Ukrainian).
2. Borytko, N. M., Solovcova, I. A., Bajbakov, A. M.: *Pedagogical technologies: A textbook for students of pedagogical universities*, 59 p. (2006). (in Russian).
3. Bosova, L. L., Zubchenok, N. E.: "Electronic textbook: yesterday, today, tomorrow", *Obrazovatel'nye tehnologii i obshchestvo*, Vol. 16, № 3, Pp. 697–712. (2013). (in Russian).
4. Yesina, O. H., Linhur, L. M.: "Electronic textbooks: advantages and disadvantages", *Visnyk Sotsialno-Ekonomichnykh Doslidzhen Zb. Nauk. Pr.*, Vol. 44, № 1, Pp. 181–186. (2012). (in Ukrainian).
5. Zhydilova, L. O., Liashenko, K. I.: *Gaming (e-learning) as a means of improving the effectiveness of learning at math lessons in elementary school*. [Online]. Available at: [http://fitu.kubg.edu.ua/images/stories/Departments/kitmd/Internet\\_conf\\_17.05.18/s1/1\\_Zhydilova\\_Liashenko.pdf](http://fitu.kubg.edu.ua/images/stories/Departments/kitmd/Internet_conf_17.05.18/s1/1_Zhydilova_Liashenko.pdf), last accessed 2018/01/07 (2018). (in Ukrainian).
6. Lytvynova, S. H.: "Criteria for evaluating local e-learning resources", *Informatsiini Tekhnologii V Osviti*, Vol. 15, Pp. 185-192. DOI: 10.14308/ite000405 (2013). (in Ukrainian).
7. Lytvynova, S. H., Melnyk O. M.: *Use of electronic educational game resources in the elementary school educational process: method. river*, Kyiv, 84 p. (2016). (in Ukrainian).

8. Melnyk O. M.: "The experience of Ukraine in using electronic educational resources in elementary school", *Naukovyi Chasopys NPU Im. M. P. Drahomanova. Serii 2 Kompiuterno-Oriientovani Systemy Navchannia*. Kyiv, Pp. 132-139. (2015). (in Ukrainian).
9. Provisions on the electronic textbook. [Online]. Available at: <http://zakon.rada.gov.ua/laws/show/z0621-18>, last accessed 2018/01/07. (2018). (in Ukrainian).
10. Provisions on electronic educational resources. [Online]. Available at: <http://zakon.rada.gov.ua/laws/show/z1695-12>, last accessed 2018/01/07. (2018). (in Ukrainian).
11. Rybalko, O. O.: "Creating and using interactive spreadsheets in math lessons in elementary classes", *Informatsiini Tekhnolohii I Zasoby Navchannia*, Vol. 53. № 3, Pp. 38-48 (2016). (in Ukrainian).
12. Kukharenyk, V. M., Berezenska, S. M., Buhaichuk, K. L., Oliinyk, N. Yu., Oliinyk, T. O., Rybalko, O. V., Syrotenko, N. H., Stoliarevska, A. L.: *Theory and practice of blended learning: monograph*, 284 p. (2016). (in Ukrainian).
13. Pokas, L. A., Sloza, N. V.: "Formation of abilities of independent work with an electronic textbook in the process of studying physical geography", *Problemy Suchasnoho Pidruchnyky*, Vol. 15, № 2, Pp. 160-169. (2015). (in Ukrainian).
14. Shevlyakova-Borzenko, I. L., Vasil'eva, I. N.: "Theoretical and methodological bases for the development of an electronic textbook-navigator for schools of the Republic of Belarus", *Problemy Suchasnoho Pidruchnyky*, Vol. 15, № 2, Pp. 351-367. (2015). (in Russian)
15. Chulkov, D., Alstine, J.: "College Student Choice Among Electronic and Printed Textbook Options", *Education for Business*, Vol.88, №4, Pp. 216-222, DOI: 10.1080/08832323.2012.672936 (2013).
16. Gu, X., Wu, B., Xu, X. J.: "Design, development, and learning in e-Textbooks: what we learned and where we are going", *Computing Education*. Vol. 2, p. 25, DOI: 10.1007/s40692-014-0023-9 (2015).
17. Hicks, K.: 2015's Top Education Technology Trends. *Edudemic*, May 13, 2015. [Online]. Available at: <http://www.edudemic.com/education-trends-keep-tech-front-center/>, last accessed 2018/01/07 (2015).
18. Rodríguez, J., Bruillard, E., Horsley, M. (Eds.): "Digital Textbooks: What's New", Santiago de Compostela: IARTEM, DOI: 10.15304/op377.759, [Online]. Available at: <https://iartemblog.wordpress.com/2015/05/27/new-book-digital-textbooks-whats-new/>, last accessed 2018/01/07 (2015).
19. Khalid, A.: "Textbooks: E-book Vs. Print", *Journal of Education and Human Development*, Vol. 3, №2, Pp. 243-25. [Online]. Available at: [http://jehdnet.com/journals/jehd/Vol\\_3\\_No\\_2\\_June\\_2014/13.pdf](http://jehdnet.com/journals/jehd/Vol_3_No_2_June_2014/13.pdf), last accessed 2018/01/07 (2014).
20. Lytvynova, S., Melnyk, O.: "Professional Development of Teachers Using Cloud Services During Non-Formal Education". *Proc. of 1st Workshop 3L-Person'2016 (Kyiv, Ukraine, June 21-24, 2016) ICTERI, 2016*. [Online]. Available at: [http://ceur-ws.org/Vol-1614/paper\\_51.pdf](http://ceur-ws.org/Vol-1614/paper_51.pdf), last accessed 2018/01/07 (2016).
21. Marczak, M.: "Selecting an E-(Text) Book: Evaluation Criteria", *Teaching English with Technology*, Vol. 1, Pp. 29-41. [Online]. Available at: <http://www.tewtjournal.org/?wpdmact=process&did=MzQ5LmhvdGxpbms>, last accessed 2018/01/07 (2013).
22. Sun, J., Flores, J., Tanguma, J.: "E-Textbooks and Students' Learning Experiences", *Decision Sciences Journal of Innovative Education*, Vol. 10, Pp. 63-77, DOI:10.1111/j.1540-4609.2011.00329.x. (2012).

# Technologies of Virtual and Augmented Reality for High Education and Secondary School

Nataliia Osipova <sup>[0000-0002-9929-5974]</sup>, Hennadiy Kravtsov <sup>[0000-0003-3680-2286]</sup>,  
Olha Hniedkova <sup>[0000-0001-5194-2194]</sup>, Tetiana Lishchuk <sup>[0000-0003-1600-3321]</sup>,  
Kateryna Davidenko <sup>[0000-0001-8825-0749]</sup>

Kherson State University, 27, Universitetska St., 73000, Kherson, Ukraine

Natalie@ksu.ks.ua, kgm@ksu.ks.ua, Gnedkova@ksu.ks.ua,  
tsuoi96@gmail.com, leoverenskaya@gmail.com

**Abstract.** Every year there are new technologies used in the education of the younger generation. The introduction of mobile and portable devices in the educational process helps to improve the quality of educational materials by software. It complements or expands the content of textbooks and workbooks. The main trend in software development of educational purposes is the system of virtual and augmented reality.

VR and AR-technologies provide an opportunity to interact with various branches of science, ranging from virtual excursions and object studies to experiments in Physics, Biology, Chemistry, Astronomy, etc. Virtual and augmented realities are unique learning environments in various fields of science reproducing virtual models in details.

There are ready-made products designed for use in specific subject areas. Most software for learning in virtual and augmented reality have English language interface, so it's a need to develop educational software for Ukrainian-speaking students and pupils.

**Keywords:** Virtual reality, Augmented reality, IT, ICT, technology, mobile application, secondary school.

## 1 Introduction

The improvement of teaching methods and the introduction of information technologies in education are priorities for today. In order to modernize the education system and popularize science, in recent years, virtual and augmented reality technologies (VR, AR) are actively used and researched in teaching. The development and research of these technologies began in the 1950s, but the heyday of VR and AR technologies has become the last decades.

**Augmented reality (AR)** is an interactive experience of a real-world environment where the objects that reside in the real-world are "augmented" by computer-generated perceptual information, sometimes across multiple sensory modalities, including visual, auditory, haptic, somatosensory, and olfactory [1].

The primary value of augmented reality is that it brings components of the digital world into a person's perception of the real world, and does so not as a simple display of data, but through the integration of immersive sensations that are perceived as natural parts of an environment.

**Virtual reality (VR)** is a popular information technology (IT) area that provides an indirect experience by creating a virtual space that interacts with the human sensory systems and overcomes spatial and physical constraints of the real world (Electronics and Telecommunications Research Institute (ETRI), 2001).

VR technology can be categorized as follows: expression technology for stimulating human sensory systems, interaction technology for interfacing reality with VR, authoring technology for developing VR content, and collaboration technology that networks multiple participants within VR (ETRI, 2001) [2].

Using objects of these technologies allows the teacher to quickly and affordably to explain a large amount of theoretical material, and students to learn effectively it develops in them a creative thinking and enhances the motivation to learn.

Scientists, teachers and students are actively engaged in technology research and concepts of virtual reality in Ukraine and abroad.

Ukrainian authors Iryna Melnyk, Nadezhda Zaderey and Galina Nefyodova in their work "Augmented Reality and Virtual Reality as the Resources of Students' Educational Activity" [3] describe not only the importance of virtual and augmented reality technologies, but also reveal the concept of unified reality (merged reality, MR), in which the boundaries between augmented, virtual and physical worlds are erased. Experts of the research division of Ericsson ConsumerLab, studied the influence of AR and VR technologies on the habits and preferences of users and were the first to come to this conclusion. In work [4], the author describes the process of using virtual reality with new opportunities in learning and education.

From the works of foreign scientists, we identified two of the most interesting – "Virtual reality: A brief survey" by scientists from India Namrata Singh and Sarvpal Singh, which was published in 2017 by "International Conference on Information Communication and Embedded Systems (ICICES)" [5] and "The Reality of Virtual Reality" (by Myeong-Sook Yoh) [6]. In these works, the authors explore the concept of virtual reality, its history and set out the ontological difference between virtuality, possibility and actuality. This makes it possible to understand the essence of virtual reality in various aspects of its use.

The offered model of the training system was tested in the classrooms of school-children in the learning process at the STEM school established at Kherson State University in 2017. The "Experience of STEM-School" article (written by Nataliya Kushnir, Nataliya Valko, Nataliya Osipova, Tatiana Bazanova) [7] was written and published about the STEM school by teachers and students of the CDU; place in the educational system.

## **2 Description of the learning system model using VR and AR**

Describe the definitions of basic concepts. By **the learning system with using VR and AR**, we understand an ordered set of interrelated elements of electronic educational resources, forms and means of planning and conducting, monitoring, analyzing,

correcting the educational process, aimed at improving the efficiency of student learning [8].

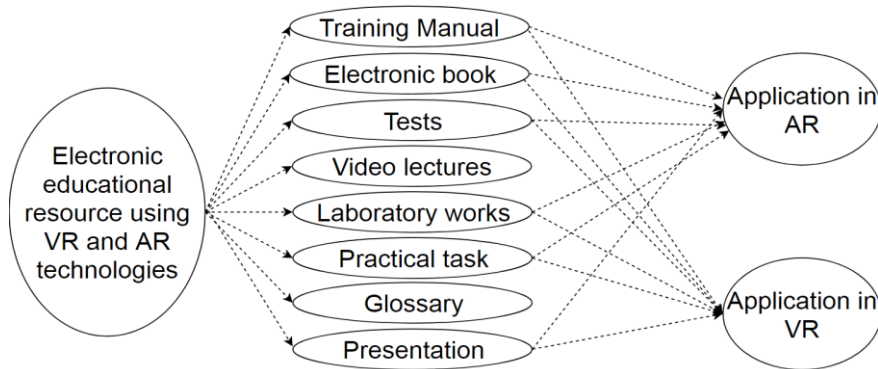
The term “**trigger image**” will be understood as any image on the pages of an electronic textbook that has the properties of a trigger for a mobile application and allows displaying elements of augmented reality on the device.

A **virtual object** is a 3D object that is displayed and used in a mobile application for demonstration in AR.

In the **learning system using VR and AR**, we use the following forms adapted for distance learning using information and communication technologies, namely:

- lectures;
- training manual;
- laboratory works;
- testing;
- lecture videos;
- practical tasks;
- glossary;
- presentations.

A model of this system is shown in Fig. 4.



**Fig. 1.** Model of a learning system using VR and AR.

A training manual is a book or booklet of instructions, designed to improve the quality of a performed task. An electronic book, also known as an e-book or eBook, is a book publication made available in digital form, consisting of text, images, or both, readable on the flat-panel display of computers or other electronic devices. A test is an assessment intended to measure a test-taker's knowledge, skill. A test may be administered on a computer that requires a test taker to demonstrate or perform a set of skills. A video lesson or lecture is a video which presents educational material for a topic which is to be learned. Laboratory and Work and Practical task - one of the forms of independent practical work for students in higher, specialized secondary, and general schools. A glossary, also known as a vocabulary or clavis, is an alphabetical list of terms in a particular domain of knowledge with the definitions for those terms.



Presentation is a document or set of documents intended to represent the subject under study. The presentation can be a combination of text, hypertext links, computer animation, graphics, video, music, which are organized in a single environment.

Before creating a learning system using VR and AR, a scenario plan is required, which should include the following components:

- name of e-learning resources: e-learning resource using VR and AR technologies;
- class e-learning resources: Multimedia electronic educational resource;
- a brief description of the content of the e-learning resources: This learning system using VR and AR is designed to teach students in grades 5-7 the basics of robotics;
- number of elements and their description: This learning system using VR and AR consists of the following elements - an electronic textbook, an electronic manual, tests, multimedia technology, a VR application, an AR application;
- list of tools used: This system is planned to be developed by means of Moodle, additional applications for VR and AR are developed by means of Unity3D, Vuforia and Autodesk 3ds Max;
- presence of interactivity and multimedia: This system contains multimedia and interactive elements - tests, videos, simulators;
- description of the user interaction with the content: User interaction is carried out through data exchange with the system server (the User can download the necessary resources and also enter data during the test);
- indication of the software required to work with the e-learning resource: Windows Vista and above, dual-core processor with a frequency of 3 GHz, 2 GB of RAM (4 GB for Windows Vista and above);

When creating an e-learning resource, the following tools are used:

- Simple means of publishing ESM, based on the use of applications Adobe Acrobat and Microsoft Office (Word, Excel, PowerPoint), as they are most convenient when creating and publishing electronic textbooks and guidelines for them.
- Adobe Flash and Adobe Animate CC are used to develop animation within the framework of ESM.
- To create VR and AR applications, multimedia technologies (3ds Max, Unity 3D, C #, JavaScript, Vuforia) are used.
- When designing the program, UML modeling tools are used (www.draw.io).

### **3 Technologies of Virtual and Augmented Reality in model of educational system**

Let us consider in more detail the use of VR [9] and AR [10-12] technology on the example of systems for demonstrating the progress of laboratory work.

- **The system for demonstrating the progress of laboratory work in virtual reality** consists of the following elements: a VR helmet, a mobile device, an application for demonstrating the progress of laboratory work (Fig. 2).

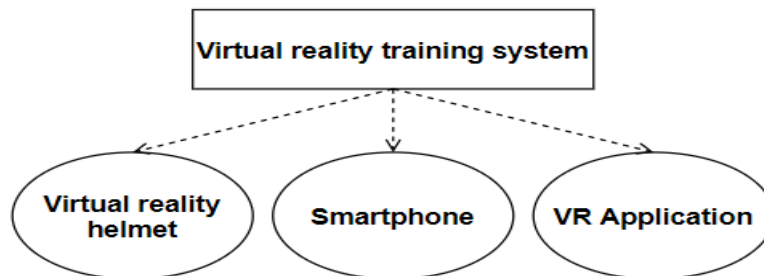


Fig. 2. Components of the virtual reality training system

**Head-mounted display** - a device that allows you to partially immerse yourself in the world of virtual reality, creating a visual and acoustic effect of being in a given control device (computer / smartphone) space. It is a design worn on the head, equipped with a video screen and a speaker system or a special connector for a smartphone.

**The smartphone** is a mobile phone, complemented by the functionality of a pocket personal computer.

**VR Application** is an interactive smartphone application with virtual reality glasses.

- **The system for demonstrating elements from laboratory works in AR** consists of the following elements: a textbook, a trigger image, a mobile device with a camera, an application for the demonstration of elements from laboratory works in augmented reality (Fig. 3).

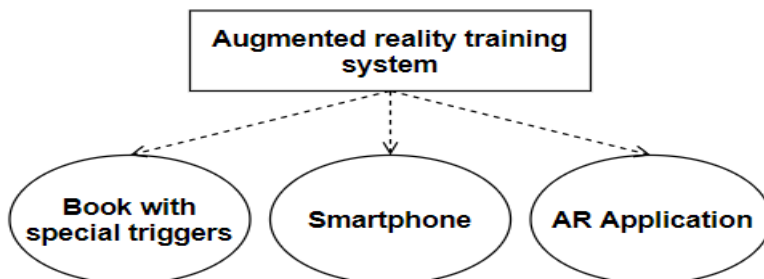


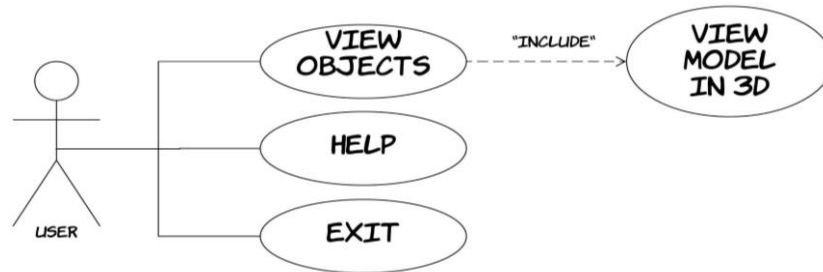
Fig. 3. Components of the augmented reality training system.

#### 4 Software modeling and design (UML diagrams)

The application for learning using augmented reality consists of the following components:

- “Help” (instructions for this application),
- “Exit” (exit from the application),
- “View object” (the camera screen for trigger scanning appears).

The diagram of use cases for augmented reality training application is shown in Fig. 4.

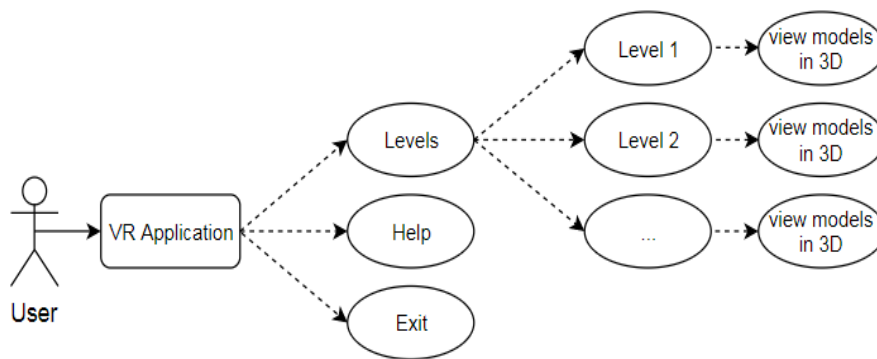


**Fig. 4.** Use case diagram for AR application.

The virtual reality training application consists of the following components:

- “help” (instructions for this application),
- “exit” (exit from the application),
- “levels” (opens the screen to select the level of the game),
- “level” (opens the selected level).

The diagram of use cases for the virtual reality training application is shown in Fig.5.



**Fig. 5.** Use case diagram for VR application.

The sequences of user actions when working with the application for learning augmented reality and virtual reality are shown in Fig. 6.

An example of designing classes in the development of virtual and augmented reality applications is shown in Fig.7.

## 5 An example of using a learning system using VR and AR

Let us consider in more detail the process of modeling and designing VR and AR learning objects on the example of the system of laboratory work used at the STEM School of Kherson State University.

When developing a system, the book “Quick start. The first steps in mastering the Arduino.” - Publisher: Makskit, 2015, 80 c. To use the AR and VR environments, the student needs to install two corresponding applications on his smartphone.

When application for AR launched, the student gets to the main menu of the program:

- By clicking on the “help” button you can find out the instructions for this application.
- By clicking on the “exit” button will close the application.
- By clicking on the “view object” button, the camera screen appears.

After the camera screen appears, you must aim the camera lens on the page with the task. The program recognizes the image trigger. Each trigger is unique. He links the 3D image and page of the book with the corresponding task. As a result, a moving 3D object will appear on the screen against the background of the corresponding page of the book.

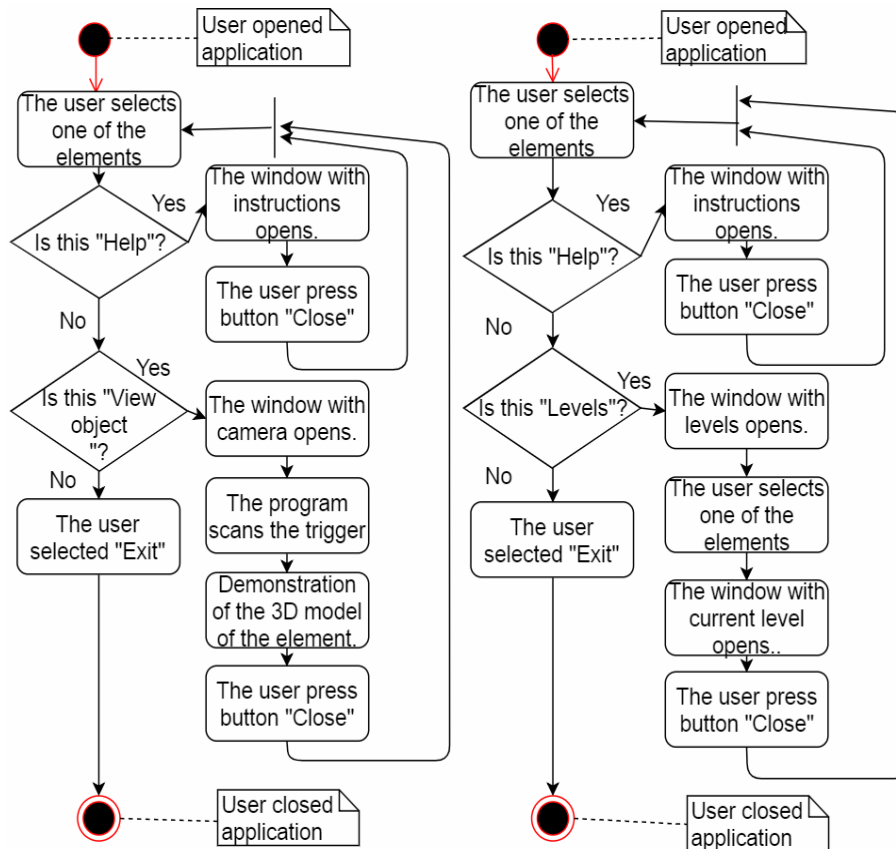
When application for VR launched, the student also gets to the main menu of the program:

- By clicking on the “help” button you can find out the instructions for this application.
- By clicking on the “exit” button, it will close the application.
- By clicking on the “levels” button, a screen appears to select the level of the game that corresponds to the lab number.
- By clicking on the “level 1” button, the user is inside the virtual space, organized according to the requirements put forward to conduct this virtual laboratory work.

After the user opens a certain level, he has the opportunity to study in detail all the game 3D objects in virtual reality, their approximation and manipulation with them. Since the inclusion of a certain level of the program is in standby mode, user actions. At the moment of performing a certain action with objects, the user in the background sees clues to what is happening in front of him.

The model of the laboratory work consists of the following objects:

1. Room (4 walls, floor, ceiling);
2. Interior items (lamp, table, chair, window);
3. A set for demonstration of laboratory works (Arduino microcontroller, breadboard, wire, resistor, LED, button, buzzer);
4. Interface elements of the application.



**Fig. 6.** a) Activity diagram for AR application; b) Activity diagram for VR application.

For a better understanding of the technical characteristics inherent in the objects used in this model, consider the description of meta-objects, objects in the real world and objects used in laboratory work.

Let us give an example of the description of the characteristics of meta-objects used in laboratory work in virtual and augmented reality:

Arduino microcontroller: length, width, weight, operating voltage, input voltage, number of digital outputs, number of analog outputs, maximum output load current, size of program memory, size of data memory, size of nonvolatile memory, clock frequency, availability of Ethernet controller, the availability of data storage devices, materials;

Development board: length, width, height, number of points, distance between points, manufacturer, materials;

LED: length, diameter, glow color, glow angle, voltage, current consumption, manufacturer, materials;

Here is a description of the characteristics of objects used in laboratory work in virtual and augmented reality:

- Arduino microcontroller: length, width, height.
- Development board: length, width, height;
- LED: length, width, height;

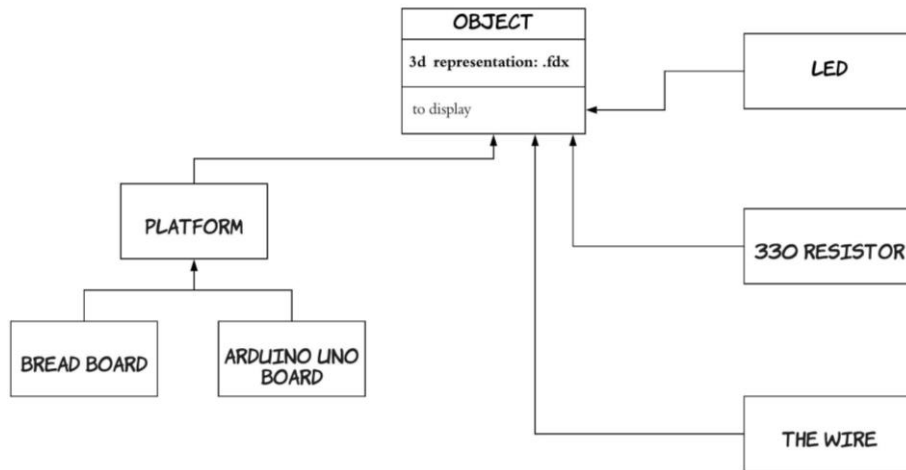


Fig. 7. Class diagram for VR and AR application.

The interaction of objects occurs after the user clicks on certain control buttons that trigger the trigger set on the interaction between objects.

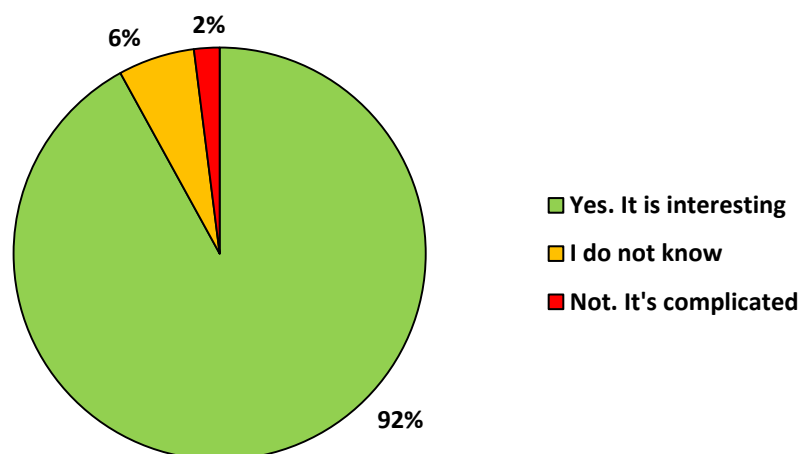
Consider the interaction between objects on the example of laboratory work №1 “Connecting the LED”. A fragment of the interaction of objects in the laboratory work is as follows. After pressing the button of the subsequent action, the “LED” object is connected to the “prototyping board” object, then the application is in the standby mode of the subsequent pressing of the button of the subsequent action. Also, the user can personally perform actions with objects by rotating and moving in space.

We conducted classes at STEM School using VR and AR. At the end of the lesson, the students passed a social survey on whether they would like to use VR and AR technologies in the classroom.

1. Do you know what VR and AR technologies are?
2. Do you want to use VR and AR technologies at school?
3. Do you have an experience of using VR and AR technologies?
4. What do you think, are VR and AR technologies interesting to use it on classes?
5. Have you used VR and AR technologies before?
6. Did you use VR and AR technologies in the classroom?
7. Do you want to study robotics using VR and AR technologies?

8. Do you think that the use of information and computer technology can make preparation for classes easier and allows teacher to diversify them?
9. Do you like to use the new technologies on classes?
10. What do you think - is it necessary to introduce the VR and AR technologies on robotics classes?

These 10 questions were asked to 34 pupils from STEM school. The research was conducted and showed next results on Diagram 1.



**Diagram 1.** Social survey at STEM-school.

## 6 Conclusion and future work

The improvement of teaching methods and the introduction of information technologies in education are priorities for today.

The research showed the active development of STEM education in Kherson State University and around the world.

The use of STEM, AR and VR technologies allows the teacher quickly and affordably explain a large amount of theoretical material, and students learn effectively. It develops creative thinking in them and increases motivation to study.

This direction is able to realize the need for engineering personnel and specialists in the field of information technology. In this regard, we proposed a model of a learning system using virtual and augmented reality technologies.

The direction is very promising in the system of higher and secondary education. Teachers and students can use this electronic resource both at school and university classes, and at home.

A survey conducted among STEM school students showed the willingness of students to work with virtual and augmented reality technologies.

The developed model should be used as a means to create a basis for future research, development and dissemination in the system of educational institutions.

The offered model of the training system was tested in the classrooms of school-children in the learning process at the STEM school established at Kherson State University in 2017-2018.

In the future, we plan to introduce a system that uses virtual and augmented reality technologies into the STEM school educational process at Kherson State University.

## References

1. Virtual reality. [https://en.wikipedia.org/wiki/Virtual\\_reality](https://en.wikipedia.org/wiki/Virtual_reality)
2. Sang Su Choi, Kiwook Jung and Sang Do Noh. Virtual reality applications in manufacturing industries: Past research, present findings, and future directions. (2015). Access mode: [https://www.researchgate.net/publication/273514630\\_Virtual\\_reality\\_applications\\_in\\_manufacturing\\_industries\\_Past\\_research\\_present\\_findings\\_and\\_future\\_directions](https://www.researchgate.net/publication/273514630_Virtual_reality_applications_in_manufacturing_industries_Past_research_present_findings_and_future_directions) [accessed Mar 25 2019]
3. Iryna Melnyk, Nadia Zaderei, Galyna Nefodova. Augmented Reality and Virtual Reality as the Resources of Students' Educational Activity. Proceedings of Information technology and computer modelling (2018). Access mode: <http://itcm.comp-sc.if.ua/2018/melnuk.pdf>
4. Trach Yu.V. VR technology as a method and learning tool. Educational discourse. No 3-4, P. 309-322 (2017). Access mode: [http://nbuv.gov.ua/UJRN/osdys\\_2017\\_3-4\\_26](http://nbuv.gov.ua/UJRN/osdys_2017_3-4_26)
5. Namrata Singh, Sarvpal Singh. Virtual reality: A brief survey. IEEE Xplore (2017). Access mode: <https://ieeexplore.ieee.org/document/8070720>
6. Myeung-Sook Yoh. The reality of virtual reality. IEEE Xplore (2002). Access mode: <https://ieeexplore.ieee.org/document/969726>
7. Nataliya Kushnir, Nataliya Valko, Nataliya Osipova, Tatiana Bazanova. Experience of Foundation STEM-School. Proceedings of the 14th International Conference on ICT in Education, Research and Industrial Applications. Integration, Harmonization and Knowledge Transfer. Volume II: Workshops. Kyiv, Ukraine, May 14-17 (2018)
8. Pietro Cipresso, Irene Alice Chicchi Giglioli, Mariano Alcañiz Raya, and Giuseppe Riva. The Past, Present, and Future of Virtual and Augmented Reality Research: A Network and Cluster Analysis of the Literature. Frontiers in Psychology (2018). Access mode: <https://www.ncbi.nlm.nih.gov/pmc/articles/PMC6232426/>
9. Stephen Khan. What is augmented reality, anyway? The Conversation (2018). Access mode: <https://theconversation.com/what-is-augmented-reality-anyway-99827>
10. Ole Baunbæk Jensen. Getting Started with Virtual Reality in Research. iMotions (2018). Access mode: <https://imotions.com/blog/virtual-reality-research/>
11. Jun He, Peng Han, Huan Liu, Shiyang Men, Lu Ju, Pu Zhen, Ting Wang. The research and application of the augmented reality technology. IEEE Xplore (2018). Access mode: <https://ieeexplore.ieee.org/document/8284781>
12. Tony Liao. Future directions for mobile augmented reality research: Understanding relationships between augmented reality users, nonusers, content, devices, and industry. Mobile Media & Communication (2018). Access mode: <https://journals.sagepub.com/doi/abs/10.1177/2050157918792438?journalCode=mmca>



# Activity Plan Template for Supporting Study Science with Robotics and Programming

Tatiana Goncharenko<sup>1</sup>[ID 0000-0002-2021-9320], Nataliya Kushnir<sup>1</sup>[0000-0001-7934-5308],  
Nataliia Valko<sup>1</sup>[0000-0003-0720-3217], Nataliya Osipova<sup>1</sup>[0000-0002-9929-5974]

<sup>1</sup>Kherson State University, Universytets'ka St. 27, 73000 Kherson, Ukraine  
goncharenkokspu@gmail.com, kushnir@ksu.ks.ua,  
valko@ksu.ks.ua, natalie@ksu.ks.ua

**Abstract.** Today, specialists in engineering specialties are becoming increasingly popular on the labor market. In accordance with the requirements of society, the educational system is looking for opportunities to increase children's interest in the study of subjects in the natural and mathematical cycle. The article presents the experience of holding a summer camp for children for the purpose of attracting them to scientific research and acquaintance with the courses of STEM (science, technology, engineering, and math). The teachers of the STEM-school of the Kherson State University developed the "Summer Intensive" course to familiarize children with the basics of robotics, programming and physics. The course is designed for five days, each of which includes 4 lessons: from physics in practice and experiments, the basics of robotics, the basics of programming, needlework, as well as active games, walks in the park, excursions. During two years 188 children were trained, the article contains the justification for the selection of experiments in physics for children 6-14 years old, a detailed description of their conduct, organization of acquaintance with the basics of robotics using Lego Education WeDo 2.0, programming with Scratch. Particular attention is paid to the peculiarities of the organization and the generalization of the results of training in the summer camp in general and in the context of each subject.

**Keywords:** robotics, educational robotics, STEM, ICT, robotics school programs, summer camp, physics experiment, camp program.

## 1 Introduction

The rapid development of technologies, their active introduction into all spheres of society life implies a wide awareness of citizens about the opportunities, prospects and risks of using digital technologies to ensure successful self-realization. Under the influence of automation and robotics, the labor market varies considerably: some of the professions disappear, while the other changes substantially [1]. Instead, there are entirely new professions which require competencies related to work in the team, critical thinking, having ability to make decisions and be responsible for them. Also, requirements for the level of competence associated with the use of modern technolo-

gy are significantly changing. There is an understanding that we are living in the era of digital technology and they change not only the tools of the usual professions, but also significantly change them. Today, in the labor market, particularly in Ukraine, there is an increasing demand for specialists in engineering professions. Accordingly, to the requirements of society, the educational system is looking for opportunities to make children interested in studying subjects of the natural-mathematical cycle. The STEM-oriented approach to learning is an urgent topic for the modernization of natural and mathematical education. The versatility of this approach contributes to the spreading of innovative technologies in education and popularization of engineering and technical specialties among young people. One of the ways to accomplish this task is to train children in technical circles. At the same time, the popularity of the circle of robotics for children began to grow rapidly.

**Analysis of the educational services of the Kherson region on the implementation of STEM-education.** Today, STEM-approaches are being implemented in many Ukrainian schools. Out-of-school STEM-education in the state is a diversity of Olympiads and the activities of the Small Academy of Sciences, other out-of-school establishments, and various competitions and events are: Intel Techno Ukraine; Intel Eco Ukraine; Sikorsky Challenge Science Festival; scientific picnics, hackathons and more. Great developments and interesting original approaches were made in Ukraine in this area. They are different, but have the same goal - the development of students' creative thinking [2].

In the law "On Extracurricular Education" [3], five main areas of extracurricular education are identified: artistic and aesthetic, tourist-lore, ecological-naturalistic, scientific-technical and pre-research and experimental directions [4]. It should be noted that out-of-school educational institutions working within last three directions have the opportunity to implement the principles of STEM-training.

In the course of the study, we analyzed the activities of out-of-school institutions in the city of Kherson, among which the following communal institutions of the Kherson regional council as the "Center of tourist and ethnographic creativity of student youth" [5], "Center of ecological and naturalistic creativity of student youth" [6], Center for Scientific and Technical Creativity of Student Youth [7], "Regional Aviation and Sports Technical Club" [8], "Small Academy of Sciences of Student Youth" [9].

None of the out-of-school educational institutions fully implements the research and experimental direction. However, most clubs offering municipal services in the city of Kherson have a close connection with STEM disciplines and may influence the further selection of professional activities of their pupils. However, they have the opportunity to cover a rather small part of the young residents of the city.

As for the study of the basics of robotics and / or programming, as one of the most requested directions for STEM education, it's necessary to note that a large chat group works with Arduino designers and sets of LEGO series, the most popular of which are LEGO Mindstorms and LEGO WeDo. However, today the market of designers to teach children the basics of robotics is actively developing. There are new ideas and startups in this direction.

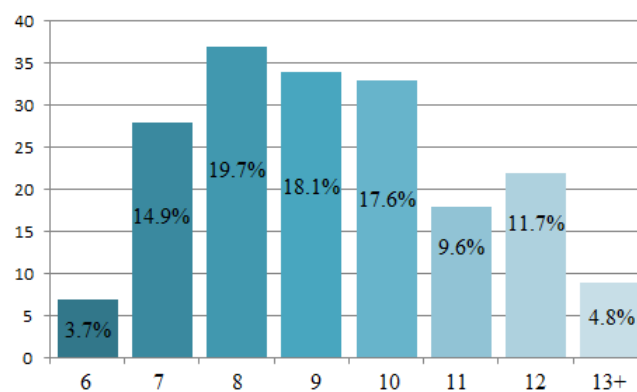
The leaders in the educational services market in this direction in Kherson are private organizations: Academy Step (working in Kherson since 2016), Ro-

boHause(since October 2015), ISchool (working since January 2018), and others. It is worth noting that the cost of training is 100-120 UAH per academic hour. Only in the last 6 months in Kherson 3 more private circles offering study of the basics of robotics for children 6-10 years by means of LegoWedo 2.0 were opened. Among the peculiarities of various private training courses, it is worth noting the teaching of the basics of robotics in English, the additional study of the English language, the study of the course "Fundamentals of Effective Communications", etc. The analysis of government agencies has shown that during 2017, Lego Wedo 2.0 and Lego Mindstorms for the regional station of young technicians (lessons for free) were purchased, as well as Arduino and Lego Wedo 2.0 for the STEM-school of the Kherson State University operating since January 2017 (cost academic hours is 40 UAH).

Therefore, society needs and interested in preparing children for professions that are in demand in the future. In recent years, the market for educational services has been growing rapidly. However, there is a significant lack of specialists capable for organizing effective STEM training. Also, it should be noted that secondary schools are trying to organize circles for the study of the basics of robotics. At the same time, there is a significant number of children who want to try themselves in the making of robots and programming. Therefore, the teachers of the STEM-school of KSU developed the program "Summer Intensive".

## 2 Related Work

**The experience of summer camp.A general description of the program and the results of the summer camp.**It should be noted that this format of combination of recreation and STEM-education was held in the region for the first time. The main tasks were to combine the rest of children with the interest in the study of physics, astronomy, programming and robotics. For two years, the summer camp was attended by 188 children, of which there were girls –43%, boys –57%. By age, the distribution of participants was as shown in Figure 1.



**Fig.1.** Distribution of children who have attended the camp by age

The greatest number of children were under the age of 10, as at the time of summer holidays, these children need to organize their activities and supervision from adults.

The course includes five days. The children were in the camp from 8:30 to 16:00. Each day consisted of four classes that could take turn each other: programming, robotics, power design (in particular drawing with a 3D pen), physics in tests and experiments. Active games, walks in the park, excursions (in particular, to the observatory, the laboratories of the KSU) meal times (the second breakfast and the complex lunch) were held between these classes according to the schedule. For the senior group, instead of maker programming, C++ classes for Arduino were conducted.

Among organizational aspects it should be noted the role of the leaders - students of KSU, future teachers who played with children, accompanied them on excursions and rides, and helped in classes together with the teachers of the STEM school. In the work of the STEM-school for the "Summer Intensive" course, teachers from the Department of Informatics, Program Engineering and Economic Cybernetics, the Department of Physics and Methods of its Training (Faculty of Physics, Mathematics and Informatics) and the Department of Preschool and Primary Education (Faculty of Preschool and in-time education) were involved.

### **3 Experimental Results**

#### **Peculiarities of physics class preparation in tests and experiments**

The main purpose of the classes was to make children interested in physics, their familiarization with various physical phenomena, states of matter, some physical properties of matter and some physical laws, as well as their involvement in research and experimental activities. Moreover, the main thing was not only demonstration of the experiment by the teacher, but involving each child to the problem, implementation and explanation of the experiment. The students had the opportunity to put forward their own hypotheses, on the posed problems, to check these hypotheses in a lukewarm manner, to draw conclusions, to put forward ideas, make predictions about the future use of physical knowledge. It gave children the opportunity to feel themselves as the makers of the future, since they allowed them to be involved in discussing scientific issues that could affect the development of technology and the life quality in general.

Taking into account different age of children who were studying at the Summer Intensive course, children were divided into two age groups: from 6 to 12 years old and from 13 to 14. Children of the first group received only a few individual physical knowledge at school during the study of natural science, but physics has not been studied yet, children of the second group - has already been studied physics at school at different levels. The different age of children, on the one hand, made it difficult for teacher to set the task of selecting material and further conducting of the experiments and their explanation at different levels of students' preparation in the classes, on the other hand, allowed the children to show themselves in mutual assistance, explaining and helping their colleagues-children during the lesson.

To conduct classes, we have selected appropriate experiments that meet the requirements: security, accessibility (cognitive and financial), the ability to be reproduced at home, clarity, brightness, ease of execution, curiosity, and scientific.

During the selection of interesting tests we carried out the analysis of educational and methodical literature and popular literature on physics (Perelman Ya. I., Entertaining physics, etc.) and Internet resources. This made it possible to conclude that there was a large number of relevant literature.

When selecting and testing the experiments we encountered a number of problems. The most common ones were: 1) lack of precise instructions on equipment and consumables; 2) the lack of nuances that are necessary for the most successful performance of the experiment; 3) the description of the explanation of the experiments should be clear to the children, but it is quite scientific, because it should cause interest to science, and not just entertain.

Example:

- in the existing “Handgum” instructions, the mark of glue has not been specified, it has led to complications during the development of the experiment at the preparatory stage, particularly: the performance of the experiment according to generally acceptable and descriptive instructions in various sources did not yield the expected result; we made the experiment using glue PVA of five different manufacturers, silica glue from four different manufacturers were tested; the only successful experiment was made with only one PVA and all silicate glues of varying degrees of quality;
- during the preparation for the "Fire Tornado" experiment it turned out that there are no precise indications regarding the size of the meta-left mesh cylinder (ratio of height and diameter of the cylinder) and speed of its rotation; There is no clarification what type of fuel (solid, liquid, and what exactly) is the best way to carry out experiments; We tested dry alcohol, liquid alcohol, and a mixture of liquid alcohol with boric acid (giving a green color). The most spectacular look was with liquid alcohol and its mixture;
- some non-Newtonian [complex] fluid explanations contradict each other, the complex scientific explanation for children is not yet clear, and the simplified explanations given on some sites are not always correct.

The "Summer intensive" course of each group took place during 5 days, hence the number of physics classes also equaled five, but their sequence, and the sequence of experiments during a separate lesson in different groups was different, depending on the set of group and individual characteristics children. The list of subjects in physics and their content is given in Table 1.

**Table 1.** List of subjects in physics and their contents

<b>Topic of the lesson</b>	<b>Elements of physical knowledge</b>	<b>The list of experiments and their discussion</b>
The Lord of element Unknown fluid	Getting familiar with various physical phe-	Non-Newtonian [complex] fluid and its diversity, different types of “hand-

	<p>nomena State of matter.  Mechanical phenomena.  Viscosity.  Properties of the liquid.  Newtonian and non-Newtonian fluids.  Ferromagnetic fluid.  Surface tension.  Capillary phenomena.  Pressure.  Density of liquid.</p>	<p>gums".  Ferromagnetic fluid.  Experiments and their discussion:  water in a glass (turning a glass of water covered with paper); wetting napkins; "Cowhide pepper" (sprinkle in water with ground pepper and cute).  Change of fluids of different density in places (with a lower density up, with a larger - bottom). Lava lamp</p>
The Lord of fire	<p>Thermal phenomena.  Pressure. Traction.  Mechanical phenomena.  Aerodynamics</p>	<p>Experiments and their discussion:  Fire tornado.  Video "The Most Odd Weather on Earth". Tornado. Discussion of the fire causes and ways to prevent them  Experiment with paper snake and candle.  Experiment "Ponder the candle behind the obstacle",  Experiment "Aerodynamic pipe"</p>
Physical illusions	<p>Optical phenomena.  Lens.  Electrical phenomena.  Sound phenomena.</p>	<p>Self-made lens from water (three ways).  Rainbow. Optical mixing of colours.  Why is the sky blue? Strange optical phenomena in nature and their explanations.  Experiment "Put a bird into the cage" (rotation of a picture).  "Sorting by electrification" experiments. Discussion: where we are faced with the phenomenon of electrification in life, in technology, in production  Sound from the glass.</p>
Flight preparation	<p>Mechanical movement.  Reactive movement.  Speed  Attraction</p>	<p>We make and launch missiles. Reactive movement. Kinds of fuel.  We discuss what are the conditions of bigger range ability, which is necessary for the rocket to fly to space</p>
A human being in the Universe	<p>Astronomy  Gravitation  Attraction  The structure of the solar system  Theories of the structure of the universe</p>	<p>Model of the Universe  Excursion to the Astronomical Observatory.  Excursion to the physical laboratories of KSU</p>

Each lesson included the following steps:

- introductory speech of the teacher (revealing features of the group at the first lesson);
- creating problem situations;
- discussion, hypothesis;
- demonstration and performance of the experiment by each student;
- discussing and summarizing the results of the experiment;
- forecasting the possibilities of using the acquired knowledge;
- summary of the lesson, (reflection).

Conducting experiments in different groups revealed the following:

- the same experiments had different successes among the children of the same age, (not all children were equally interested in the same experiment). Some children preferred experiments where creativity could be demonstrated (for example, creating a snake for the study of thermal phenomena); others showed interest in experiments where motion was needed (for example, the launch of a rocket);
- the arriving children had different preferences and different levels of preparation for research and experimental activities (for example, some children showed activity during the hypothesis, discussion of the experiment, offered their versions, others only repeated the experiment);
- some children expressed a desire to take the course twice, and even three times.

It required from teacher to prepare much larger number of experiments (the duration of which would be 1.5 hours) to each session (duration of 45 minutes) in such a way as to having been focused on the first lesson at the qualitative composition of the group, and having chosen exactly the experiments that most responded to this group of children.

Examples of the different pupils' preferences of different age groups regarding the experiments discovered during the course are given in Table 2.

Table 2. Children preferences of different age groups as for different experiments

<b>Name of experiment</b>	<b>Age 5-6</b>	<b>7-9</b>	<b>10-11</b>	<b>12-16</b>
Non-Newtonian [complex] fluid	+++	+++	+++	+++
Turning a glass of water covered with paper	++	+++	+++	+++
Lava lamp	++	+++	+++	++
“Cowhide pepper”	++	+++	+++	++
Experiment with paper snake and a candle	+++	+++	++	+
Fire tornado	++	+++	+++	+++
Self-made lens from water (three ways)	++	+++	++	++
Sorting by electrification	+++	+++	+++	++
Make and launch rockets	++	+++	+++	++
The model of the Universe	++	+++	+++	+++
Excursion to the Astronomical Observatory.	+++	++	++	+++
Sound from the glass.	++	++	+++	+++

Reasons of different students' preferences are related to the following:

- the physiological capabilities of children (for example, the palm of a 5-6-year-old child is small, so turning a glass of water, covered with paper, was difficult for them for the first time);
- level of preparation (experiment with a snake on fire for some older children was known, but very much liked by the younger ones, because it included the creative component - the preparation and coloring of the snake);
- personal preferences of children (among the older children, many were interested in astronomy).

But all children liked to do experiments on their own, as well as to feel them-selves as inventors, who are listened to, to feel successful.

### **Peculiarities of classes preparation the basics of robotics**

Previously, materials for each type of training were prepared and analyzed. All results were collected on the online resource [www.ksuonline.kspu.edu](http://www.ksuonline.kspu.edu).

For the classes on programming and robotics, the following software and platforms were considered:

Scratch has a GNU GPL license, which is free. This programming environment can be downloaded freely and used freely at school or extracurricular education.

Arduino (Arduino) is an open source Arduino Software (IDE) platform.

Scratch for Arduino (S4A) is a Scratch modification that allows easy programming of the Arduino open source hardware platform.

Modelling - there is an online resource called Tinkercad to create Arduino sensor connection schemas on the docking board, as well as to create mobs that will be printed on a 3D printer.

Schematics - there is an on-line resource Easyeda or CircuitLab for the creation of electronic circuits.

Lego WeDo 2.0 - software for implementation of training projects of Lego motorized models.

A number of author programs on robotics and programming approved by the Ministry of Education and Science have been established in Ukraine. They are generally intended for the work of out-of-school circles, or for training courses and technical creativity of choice. We have analyzed [9-13].

Lego Wedo 2.0 construction sets were chosen for children aged 6 to 10 years for classes on robotics. Appropriate methodological support was used, but elements of the competition were added to the format of classes, for example, race of collected cars.

The course Lego WeDo2.0 offers the use of educational constructors LEGO and hardware-software as a tool for teaching students in the design, modeling and computer management in Lego-design classes.

Robotics of LEGO combines the possibilities: the development of fine motor skills by working with small parts of designers; mathematics skills (comparing parts by size); skills of construction, familiarity with the fundamentals of mechanics and propedeutics of engineering education; first programming experience; teamwork (the



robot is done by 2-3 pupils); skills of presentation (when the project is completed, it is necessary to present it).

The purpose of Lego Wedo 2.0 is: the organization of employment of schoolchildren in after-hours, the logical thinking development; construction skills development; motivation to study the sciences of the natural-science cycle: Physics, Computer Science (programming and automated control systems) and Mathematics. At each lesson the following tasks were realized: familiarization with the basic principles of mechanics; familiarization with the basics of programming in the Lego Wedo 2.0 environment; development of the ability to work according to the proposed instructions; development of the ability to do the task creatively; development of the ability to bring the solution of the problem to the working model; the development of the ability to express thoughts in a clear logical sequence, defend the point of view, analyze the situation and independently find answers to questions through logical reasoning, development of the ability to work on a project in a team, effectively allocate responsibilities, training for Lego-design competitions.

The result of the work of students in classes Lego Wedo 2.0 is the creation of real models of robots; control behavior of robots with the help of simple programming; practical application of design, engineering and computing skills.

In classes on robotics we picked classes so that they were consistent with the subject of physical experiments. In the case when the child has already collected the model previously planned, we proposed that it improve the algorithm of the model and complement its functionality. At the beginning of the classes, the children collected the basic models that are in the designer's software. After that they were offered other models, some of which are given in Table 3.

**Table3.** Suggested models from Lego Wedo 2.0 by themes

<b>Topic of the lesson</b>	<b>Devicemodel</b>	<b>Elements of physical knowledge</b>
The Lord of element Unknown fluid	Windmill, windfarm, mixer	Gearsdownshiftingandupshifts
The Lord of fire	Fan, helicopter, dam	Torque, speed and direction
Physical illusions	Piano, swing, caterpillar	Sound, soundcharacteristics, balance, centerofmass, reliabilityofstructures
Flight preparation	Catapult, plane, racingcar	Speedandtrajectoryofmotion, determiningthepath, time, speedoftransport
A human being in the Universe	Solarsystem, dinosaurs	Laws ofgravity, heliocentricsystem

In the classroom, the project methodology was used. The topics of the projects were related to the modeling of animals (frog, bee, crocodile) and their behavior; building models of modern machines and mechanisms, studying the principles of their work (car and truck, helicopter, crane, etc.) and programming robots to carry out their tasks. The important aspect of the implementation of each project is research activity.

### Peculiarities of class preparation in programming

When choosing a program for programming classes, benefits were provided for programs that meet the criteria:

- Free Software
- Easy to study and use.
- Ability to study programming structures (cycles, branches, etc.).
- Game story.
- Ability to create finished software product in a short time.

Among all the options, Scratch is served best by these criteria - an introductory programming language that allows young children to create their own creative games, interactive stories.

For the classes, a Scratch program library was created with instructions how to complete each assignment. In addition, the resources of the Ukrainian National Volunteer Clubbing Network Code-Code (<https://codeclub.com.ua/>) were used and the training resources of the site [www.Code.org](http://www.Code.org) were used at separate lessons.

What typical problems have been arisen (for example, a repeated visit, the desire to continue walking and the third time, but for another program).

The course of studying programming is based on the age categories of children and has three levels of different projects:

1. Initial course - for beginners, also for the age group of 6-8 years. The basics of programming in Scratch and its commands are studied.
2. The main course - to master the skills of making the main stages of the game. Contains step-by-step tools for creating programs.
3. Programming games - for advanced users. Age category "10+". Contains step-by-step instructions for creating a game in the form of explanations for the implementation of game logic ("algorithms") without the script's details.

Initial course	Main course	Game programming
<input type="checkbox"/> Dress the doll	<input type="checkbox"/> A bug and a star	<input type="checkbox"/> Rock-paper-scissors
<input type="checkbox"/> Discotheque	<input type="checkbox"/> Halloween	<input type="checkbox"/> Lottery
<input type="checkbox"/> Seasons	<input type="checkbox"/> Decorations for the Christmas Tree	<input type="checkbox"/> Garbage sorting
<input type="checkbox"/> Magic sphere	<input type="checkbox"/> Bugs VS Insects	<input type="checkbox"/> Magic lines
<input type="checkbox"/> A bug and a star	<input type="checkbox"/> Gather apples	<input type="checkbox"/> Three on the ice
<input type="checkbox"/> Multiplication table	<input type="checkbox"/> Underwater world	<input type="checkbox"/> Sequence of colours
<input type="checkbox"/> Princess Frog	<input type="checkbox"/> Star Wars	<input type="checkbox"/> Tick-tack-toe
<input type="checkbox"/> A pencil		
<input type="checkbox"/> Football		

Fig.2. The names of Scratch game programs that match each level

Each of the classes took place in five stages:

- demonstration of a finished project by a teacher (up to 5 minutes),
- discussion of new commands in the program, project scenario - rules of sprites' behavior and the order of events (5-10 minutes),
- creation of own project by children (30 minutes) - with a break on sport activity,
- testing-correction (5 minutes),
- demonstration (presentation) of the project (10 minutes).

Each project is designed for 1 hour of work. Each step is important. In the process of creating their own projects children have an opportunity to choose their own heroes, the scene, as well as create their own rules of heroes' behavior of the project. Therefore, the final stage of the demonstration of its project is obligatory.

There are different ways to demonstrate your projects:

- Demonstration of the game to other students in the group - can play a game of each other.
- Publish on the Scratch Community site at <https://scratch.mit.edu/>.
- Inviting parents to submit projects.

It is also a great opportunity to develop communication skills. Children can leave comments and suggestions on improving projects to each other, as well as ask questions during the presentation of works.

Initial and basic course projects contain step-by-step instructions that simplify the stage of building a self-project and training in general, without limiting the scope for implementing additional project scenarios. These tools help form students' confidence in their abilities and provide the basis for success.

Game programming projects also go through five stages of creation, but do not include step-by-step instructions. They contain only steps to create game logic ("algorithms") and separate blocks of scripts. Such projects allow you to create a personal game with similar logic of behavior of sprites and events. Each student can create their own version of the game according to their own preferences. The purpose of such projects is not in the reproduction of the model, but in helping implement certain steps of the logic of the game.

## **4 Conclusions and Future Work**

The experience of conducting the training at the Summer Intensive course showed the high interest of children in studying STEM: 3 children attended three sessions of five, another 12 - two sessions (despite the fact that the curriculum did not change significantly), 26 children continued their studies at STEM-school on a permanent basis from October 2017. Parents expressed interest in attending classes on the autumn and winter holidays. The next direction of work for organizing classes next summer is the development of thematic changes that are inspired by one idea. It will also provide the opportunity to expand the range of STEM subjects and to diversify learning in different ways.

The pace and breadth of the STEM movement, as well as the support and interest of the state in Ukraine, show that, within three to five years, STEM-based methods and tools will be almost fully integrated into school curricula. At the same time, the material and technical support, as well as the professional development of teachers, are crucial for the pace of integration

## References

1. Stella Fayer, Alan Lacey, and Audrey Watson STEM Occupations: Past, Present, And Future, U.S. Bureau of Labor Statistics, <https://www.bls.gov/spotlight/2017> (in English)
2. Zubareva's Tatiana's blog-: <http://pvschool8math.blogspot.ru/2015/11/stem.html> (in Russian)
3. The Verkhovna Rada of Ukraine; Law on extracurricular education 22.06.2000 № 1841-III; <http://zakon0.rada.gov.ua/laws/show/1841-14> (in Ukrainian)
4. Extracurricular education of Ukraine: <http://mon.gov.ua/activity/education/pozashkilna-osvita/pozashkilna-osvita-ukrayini.html> (in Ukrainian)
5. Center of tourist-local lore creativity of students: <http://oblurcentr.ks.ua/> (in Ukrainian)
6. Center for ecological and naturalistic creativity of student: <http://junnat.kherson.ua> (in Ukrainian)
7. Center for Scientific and Technical Creativity of Student Youth: <http://cnttum.ks.ua> (in Ukrainian)
8. Small Academy of Sciences of Student Youth: <http://mankherson2011.klasna.com/ru/site/lessons.html> (in Ukrainian)
9. Lysenko T.I. The curriculum of the optional course (the curriculum "Technologies. 10-11 grades) by T.I.Lysenko, B.O. ShevelKremenchuk, 2014.
10. Dzyuba S.M. The curriculum of the optional course of labor training and technical creativity for 5-9 classes of secondary schools by S. M. Dzyuba, I.V. Keith, O.G. Keith G.V. Michurina, SA Khachatryan Kiev, 2013.
11. Dzyuba S.M. The curriculum of the optional course of labor training and technical creativity for 5-9 classes of secondary schools by S.M. Dzyuba, I.V. Kit, O.G. Keith G.V. Michurina, S.A. Khachatryan, Kiev, 2013
12. Gezalova M.A. Educational program for out-of-school education of the scientific and technical direction for pupils aged 12 to 18 by M.A. Gezalova, Zaporozhye, 2013.
13. Kozhemyaka D.I. Curriculum of the circle for children aged 6-15 years by D.I. Kozhemyaka, S.M. Kucher, Kyiv, 2012.

# Determining the Level of Readiness of Teachers to Implementation of STEM-Education in Ukraine

Viacheslav Osadchyi <sup>1</sup>[0000-0001-5659-4774], Nataliia Valko <sup>2</sup>[0000-0003-0720-3217] ,  
Nataliya Kushnir <sup>2</sup>[0000-0001-7934-5308],

<sup>1</sup> Bogdan Khmelnytsky Melitopol State Pedagogical University, Hetmanska St. 20,  
72300 Melitopol, Ukraine  
osadchyi@mdp.u.org.ua,

<sup>2</sup> Kherson State University, Universytets'ka St. 27, 73000 Kherson, Ukraine  
valko@ksu.ks.ua, kushnir@ksu.ks.ua

**Abstract.** Research of existing models of professional development of future teachers of natural and mathematical disciplines and professional teacher has shown that the creation of an educational environment for STEM-oriented learning affects the formation and further improvement of the system of their values. In this paper, the concept of STEM-education in terms of inter-discipline is considered. An attempt was also made to identify the factors that influence the readiness of teachers to support STEM-education and implement it in educational institutions. This study is concerned with determining the level of formation of teachers' readiness for the implementation of STEM-education in Ukraine. Here we propose a methodology and a model for determining the level of readiness through surveys and analysis of results. On the basis of the obtained results, further prospects of the research are proposed and recommendations for involving young people in scientific activities, which may improve learning of Science, Technology, Engineering, Mathematics (STEM).

**Keywords:** cooperation, exchange of experience, integration, collaboration, STEM, survey, questionnaire, education.

## 1 Introduction

One of the promising areas that address the issues of providing queries in the labor market, education in science, technology, engineering and mathematics (STEM-education): creation of conditions for a balanced harmonious formation of science-oriented education on the basis of modernization of the mathematical and naturalistic and humanitarian education profiles. Interest in STEM is growing worldwide. This is indicated by the number of publications and studies in different countries. For example, in a review [1] examines 44 published articles on the topic of STEAM (Science, Technology, Engineering, Arts, Mathematics) education from 2007-2018 was made. Interesting information about statistics that Google leads on request. In the world,

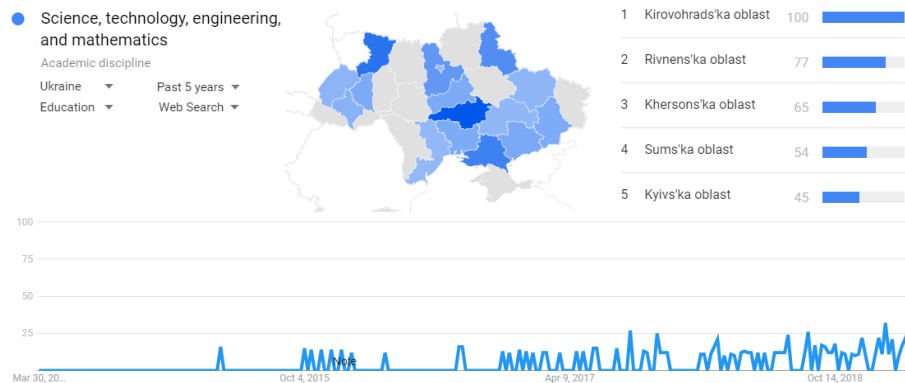
there has been an increase in interest in STEM education in the last five years (Figure 1).

In this case, searches in most cases relate to STEM-education tools, as well as degrees and levels of education, education departments, stages.



**Fig. 1.** Relative number of queries statistics on the theme of STEM in the world over the past five years

In Ukraine, STEM-education began to be interested relatively recently: the first queries appeared in 2007 year. The leaders in these queries are Kirovograd region (Figure 2). Mostly looking in the context of such phrases as: toolkit, summer camp, topic, tournament.



**Fig. 2.** Relative number of queries statistics on the theme of STEM in Ukraine over the past five years

Development and implementation of education programs in the field of science, engineering, engineering and mathematics (STEM) in the educational process is able

to provide the needs of the labor market by highly skilled professionals. Accordingly, there is a need for trained teachers, teaching methods and upgraded training programs.

“The quality of an education system cannot exceed the quality of its teachers and school leaders – and the quality of teachers and school leaders cannot exceed the quality of work organization, professional development and support provided by and to schools and local communities” [2]. Therefore, the problem of determining factors influencing the construction of a model for the professional development of future teachers in the STEM education is actual.

The purpose of the article is to study the level of formation of participants' readiness for the implement of STEM-education in Ukraine and identify of factors influencing the professional development of the future teacher of natural and mathematical disciplines.

## **2 Related Work**

Today in the world there are more than a dozen analogs of interdisciplinary integration: STREAM, STEMLE, iSTEM, eSTEM, METALS, MINT, GEMS, etc. This is a combination of basic disciplines (Science, Technology, Engineering, Mathematics) with logic, law, robotics, gender issues, ecology, etc. The leading principle of STEM-education is project activity. It has characteristics such as: interdisciplinarity (integrated learning), collaboration (active communication and teamwork), availability of results (application of scientific and technical knowledge in real life), preparation of children for technological innovation of life. Technology itself cannot create an environment for sharing knowledge, although it is a very important element of a knowledge management system. The use of modern digital technologies should support the necessary elements of interpersonal communication, because they make the process of sharing knowledge more intense. In this regard, it is necessary to pay attention not only to the material and technical part, but also to the organization of training activities.

Students cannot fully benefit from interdisciplinary studies until they acquire a solid grounding in the various disciplines that interdisciplinarity attempts to bridge [3]. Therefore, sufficient attention should be given to the basic subjects in the training of future teachers. Also, the key to learning is the support of STEM teachers by the institution of education in this direction.

The issue of STEM support by the institution of education in scientific works is called the school STEM culture. A survey carried out in [4] revealed that the issue of school STEM culture formation is an important factor in the professional activity of teachers. The main issues of the formation of school STEM culture that have expressed the focus groups of the survey can be divided into three categories: cooperation, exchange of experience, integration (Figure 3).

Cooperation	between lecturers and administration
	between teachers and parents
	in professional communities
Exchange of experience	professional development training, workshops
	in professional communities
Integration	in the curriculum of science add mathematics and technology
	Have PD specifically in STEM and technology to help illustrate discipline in-tegration

**Fig. 3.** Components of school STEM culture for [4].

In 2010, an attempt was made to compare educational curricula for teacher education in a European project SITEP [5]. The purpose of this study was to obtain information on the content of curricula for future teachers, as well as the identification of competences and skills that are important for the formation of professionals.. As a result of this study, some suggestions were made to improve the practice of pedagogical education at different stages of learning from various parameters:

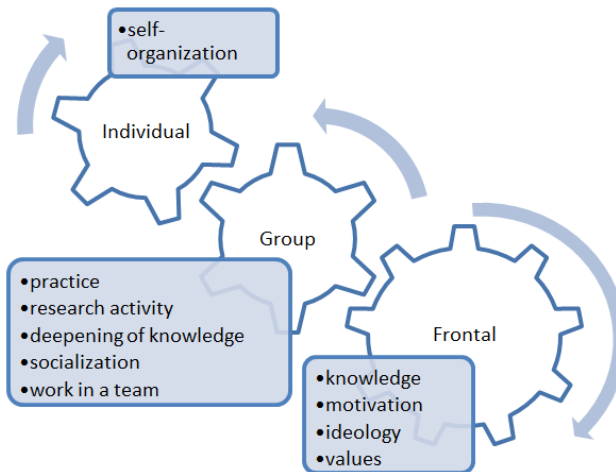
- Knowledge of the subject area is the main criterion for evaluating the learning activity of a future teacher and teacher with teaching experience.
- Self-assessment and independent professional development are sufficient for an experienced teacher, but for a future teacher it will be more expedient to manage self-esteem.
- Own learning experience is often transformed into transferring it into professional activity. Therefore, the use of teaching different practices and approaches will have a positive effect both in teaching and in the professional activity of teachers.
- Collaboration with colleagues (future colleagues) will provide an incentive for professional growth.
- Involving teachers with teaching experience in developing and implementing a rating system will enable the formation of professional standards that will affect the quality of future teachers' training.

Qualifications for teachers who are already working should be supported by short-term courses. Adult education, associated with active cognitive activity and research, creates a positive experience of using technology. It helps not only to quickly perceive information, but also to apply it in its practice and create new knowledge. [6].

According to the study [7], teachers teach how they studied themselves. Therefore, the initial training of teachers for teaching STEM, as well as advanced training, requires appropriate changes in the orientation of values, as well as in the form of training [8, 9].

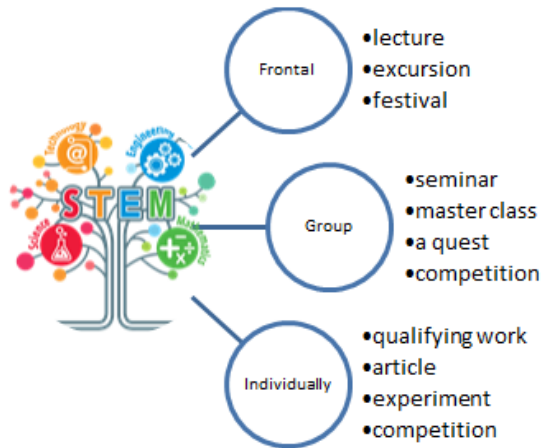


Among the organizational forms of teaching, today the most common frontal (lecture), group, individual activity (Figure 4).



**Fig. 4.** Organizational forms of education, and the emerging qualities

Each of these forms affects the development and formation of a certain group of qualities. In particular, for all forms of learning, the development of cognitive skills is inherent due to the combination of theoretical knowledge and practical activity. The use of these forms in STEM-education has modern types of cognitive activity that provide the formation of such qualities (Figure 5).



**Fig. 5.** Types of cognitive activity for various organizational forms of learning

The studies analyzed in [10] document that active learning leads to increases in examination performance that would raise average grades by a half, and that failure rates under traditional lecturing increase over the rates observed under active learning. Therefore, the usual types of cognitive activity for various organizational forms of learning should be characterized primarily by the activity of students and involve them in active discussion and problem solving.

There are different types of interaction between participants in the framework of interdisciplinary work. In work [11], interdisciplinary activities are presented as social interaction. According to the authors, interdisciplinary research is team research entailing social interaction among the research team in order that the disciplinary perspectives may interact. Therefore, for the process of actually achieving integration involves both social and cognitive elements. This work was presented four ideal types of socio-cognitive frameworks group learning:

- Common group learning - The result of the group's work is the collective intellectual property of the group. In such a group it is not possible to identify specific specialists - the expert is group.
- Modeling – is a structure that is need not be constructed by the entire research team. It may be imported intact from outside sources. Takes into account the individual contribution of each in the formation of a new intellectual result.
- Negotiation among experts – unlike common group learning, negotiation does not render team members expert in every aspect of the project. Negotiation among experts is not the dominant framework for integration. Effective integration requires to substantively reflect the inclusion of the findings of the all expert analyses of team members.
- Integration by leader – it involves a communication pattern in which the problem is divided by the leader on the basis of team members expertise. This type of interaction is more suitable for multidisciplinary.

Thus, social interaction and interaction in the professional environment are necessary and useful in terms of personal and professional growth [12].

### **3 Experimental Settings**

In order to identify teachers' readiness for the support and implementation of STEM-education in Ukraine, we conducted a survey among 144 teachers of natural and mathematical disciplines. The survey was attended by teachers from different schools and different specialties.

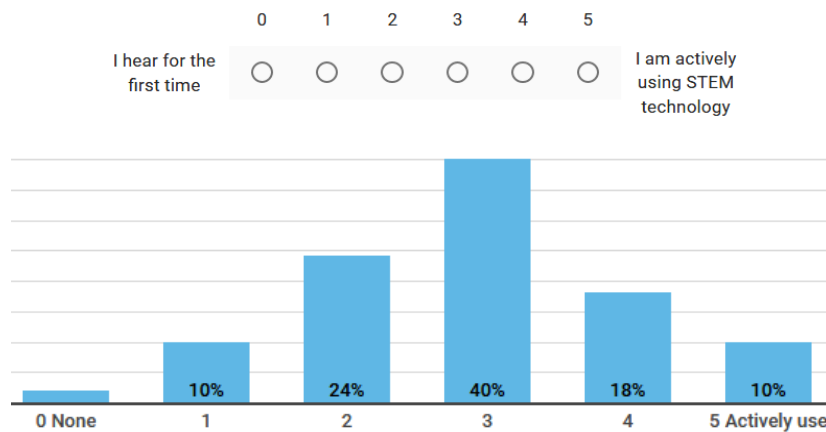
Almost a third of the respondents were teachers of natural sciences (chemistry, biology, etc.). Among respondents 83% were teachers. Teachers of the directions "Mathematics" (34.8%), "Physics" (19.6%), "Informatics" (17.4%) turned out to be the most.

The questionnaire contained three types of questions: assume one-choice answers, assessment on a scale from 0 to 5 and free-answers. Were asked teachers to rate their knowledge and skills on a five-point Laickert scale.

## 4 Experimental Results

The survey consisted of 10 questions on awareness of STEM education issues and 4 questions on the educational activity of teachers.

The question about the level of awareness in STEM education was asked to answer in scores from zero ("I hear about it for the first time") to five points ("Actively use STEM-technologies").

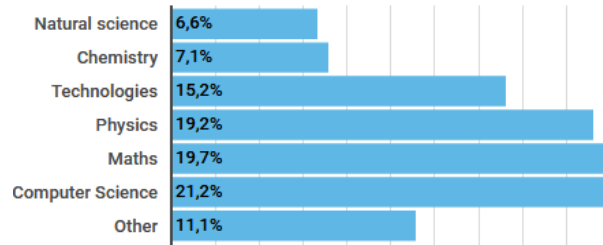


**Fig. 6.** Questions and answers about the level of awareness in STEM education

A sufficiently large number of teachers have an understanding of STEM-education, as were show answers presented in Figure 6. Against the background of previous results, the share of teachers who are not familiar with the concept of STEM education has decreased (previously it was 43%) [13]. Conducting on-line courses, webinars, popularization of festivals, as well as the work of the community of active teachers led to a better awareness of STEM-education. Some respondents answered negatively to this question. In the future, their answers were excluded from the analysis.

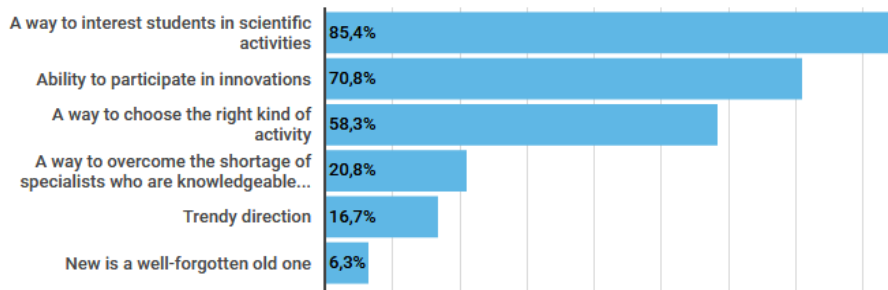
In the question of the combination of which subjects are best suited for STEM education, teachers could choose no more than four subjects.

Preference received such disciplines as computer science (21.2%), mathematics (19.7%), physics (19.2%) and technology (15.2%). All other disciplines in the nature-mathematical cycle received less than fifty percent. Some of the polled indicated philology. Such a division is due primarily to the specialization of the teachers themselves and the possible prediction of the use of STEM-education in their work. Such results can be considered a reflection.



**Fig. 7.** Answers to the question of the best combination subjects for STEM education

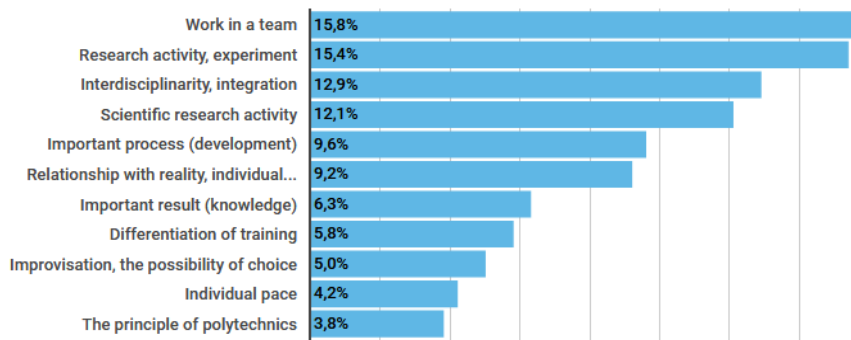
The question "Which of the statements is true for STEM-education?" The respondents were asked to select several allegations from the proposed.



**Fig. 8.** Answers-statements about STEM-education

STEM education is associated with a promising area that will help students engage in research in the world (85.4%) believe the majority of teachers. as well as the ability to be involved in innovation (70.8%). Some teachers expressed doubts about STEM education (16,7%).

On the question "How are the properties of STEM education best described it?" Several variants of options could be made in order to determine the association's educational technologies with this area of activity.



**Fig. 9.** Responses to the characteristics of STEM education

According to most teachers, the most characteristic of STEM education is team work (79.2%), research activities and the ability to experiment (77.1%). Scientific research activities (60.4%), as well as interdisciplinarity and integration (64.6%) are also important. These results are in good agreement with the results of work [4]. For the teachers is main interaction, integration, and exchange of experience, as described above.

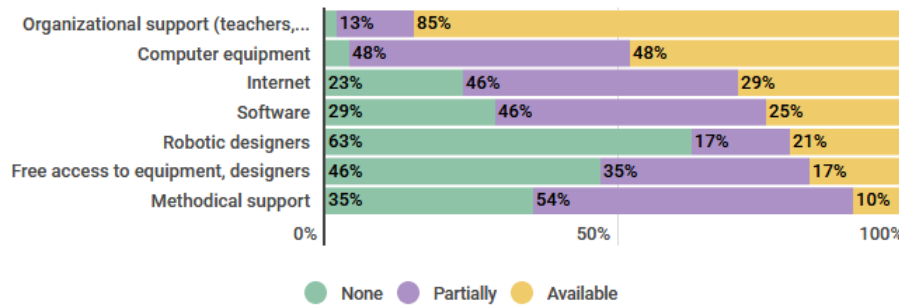


Fig. 10. Available resources for STEM training

Figure 10 shows the responses of respondents about the provision of schools to support STEM education. As can be seen from the answers, there is a lack of material and technical basis, an indirect evaluation of organizational support and methodological materials.

In the next question, the teachers could express their wishes "What is to be done to the educational establishment for the introduction of STEM-education?" (Figure 11).

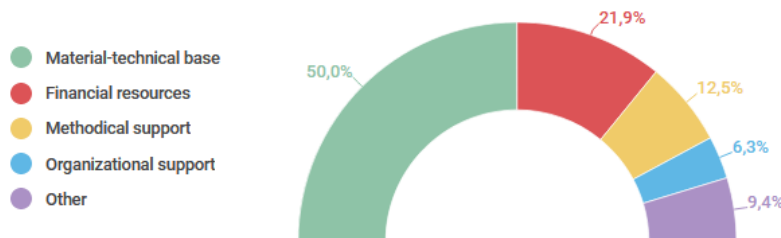


Fig. 11. The most popular answers to the question of teachers' needs for the implementation of STEM-education

Most of the teachers called for the restoration of the material and technical base and funding for this direction. But some teachers still need methodological and organizational support. It should be noted that one of the answers was "Time".

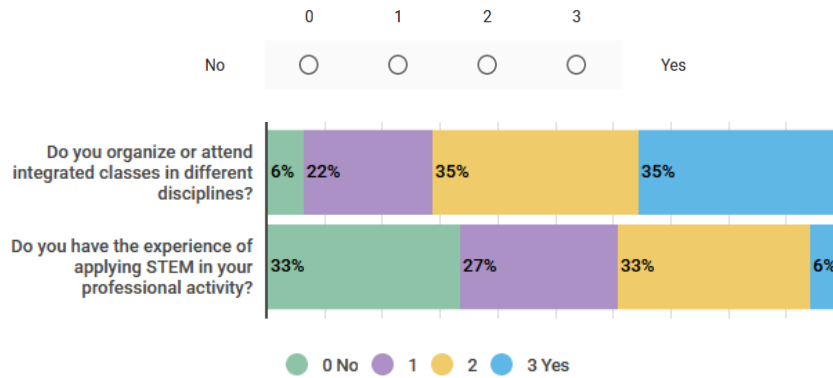


Fig. 12. Questions and answers about carrying out of integrated classes

The following two questions related to the activity of the teachers themselves: "Do you organize or attend integrated classes in different disciplines?" and "Do you have the experience of applying STEM in your professional activity?". Answers should have been indicated in scores from zero (option "No") to three points (the answer "Yes"). As can be seen from Figure 13, most of the teachers conduct integrated classes in their disciplines. At the same time, on the other question the majority answered was "no".

Such various answers say that there is still no full awareness in society and in the professional community that is STEM education and STEM technology. This concept is quite new and more attention needs to be paid to the formalization of the concepts of this direction and to familiarize the general public with its main concepts. It is also possible not to realize the value of their own activities and to compare it with existing practices.

The answers to the question "Who is the participant / organizer of which STEM events you are?" Most had negative responses. Teachers were able to determine the extent of their engagement to active engagement, as well as indicate which activities they are organizing. In the end, the answers to this question are in good agreement with the results of the previous question (Figure 13).

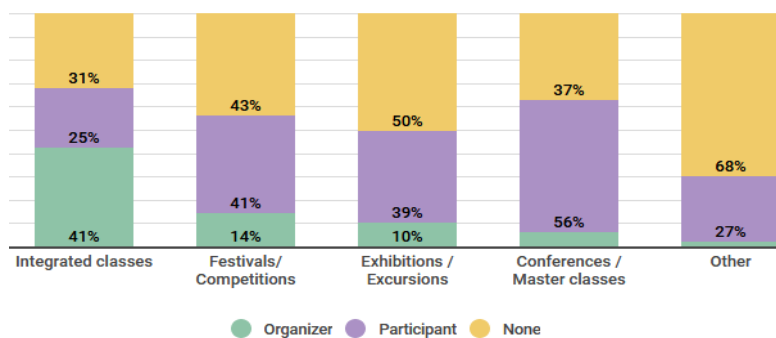


Fig. 13. Answers to questions about attending and organizing events by teachers

The relative number of negative responses was almost half of the total (47%). Other teachers are ready to participate with their students in events. At the same time, a significant number (38%) of active teachers perform passive participation as a participant, not an organizer (15%).

Relatively large activity in the integrated lessons is due to the fact that most of these lessons are conducted as Parallel Discipline Designs or Interdisciplinary Units / Courses according to the above classification [14]. That is, short-term projects that can be implemented within school activities. Among the responses to the forms of activity were basically case studies, workshops, seminars and web conferences.

## 5 Conclusions and Future Work

It is obvious that the main advantage of STEM-education is the formation of a community of specialists with a scientific outlook, ready to use technologies in their professional activities. However, this requires an appropriate organization of learning activities and other approaches to the formation of a community of teachers who are ready to support and implement this learning technology.

However, after undergoing training according to their specialty without using modern forms and methods of teaching, teachers give preference to those forms that they are known or need to be passively involved.

Using STEM-education as one of the learning technologies requires teachers and future teachers to be ready to change the educational environment and communicate in professional communities.

The survey conducted allows us to draw the following conclusions:

- Knowledge on STEM education is growing, but the general level of understanding of its basic principles as a technology and remains relatively low at this time.
- Given the recognition of the leading role of cooperation in STEM-education, part of teachers are ready to independently organize interaction in the educational activities of students. But most teachers are ready to passive participate in activities that focus on STEM education.
- Collaboration, integration and the exchange of experience play an important role in shaping the active community of STEM teachers. Therefore, in order to attract future teachers to the professional community, it is necessary to use such forms that give motivation for further improvement and influence the formation of a system of their values. To change the situation, it is necessary to include in the course of raising the skills of teachers, such activities as excursions, master classes, to engage in festivals and competitions.

The analysis of the results gives an opportunity to formulate prospects for further research. A promising direction is the development of programs of training modules for formal and non-formal education of future teachers of natural and mathematical disciplines. The influence of interdisciplinary programs on the readiness of teachers to support and introduce STEM-learning in the educational process has been proved. That is why it is necessary to create in the educational institution an educational envi-

ronment for STEM-oriented learning, which will ensure cooperation, integration and exchange of experience among all participants in the training.

## References

1. Perignat, E., & Katz-Buonincontro, J. STEAM in Practice and Research: An Integrative Literature Review. *Thinking Skills and Creativity*. (2018). doi:10.1016/j.tsc.2018.10.002
2. Lessons from PISA for Japan, Strong Performers and Successful Reformers in Education [Electronic resource], OECD Publishing, Access mode: <http://dx.doi.org/10.1787/9789264118539-en>.
3. Jacobs, H.H., and J.H. Borland., "The Interdisciplinary Concept Model. Design and Implementation." *Gifted Child Quarterly*. (1986)
4. L-Deghaidy, Heba et al. "Context of STEM Integration in Schools: Views from In-service Science Teachers." *Eurasia Journal of Mathematics, Science and Technology Education*, vol. 13, no. 6, 2017, pp. 2459-2484. doi:10.12973/eurasia.2017.01235a. [Online]. Available: <https://ore.exeter.ac.uk/repository/handle/10871/31963>
5. Menter, I., Hulme, M., Elliott, D. & Lewin, J., Literature Review on Teacher Education in the 21st Century. Report for the Scottish Government, (2010), Available at: <https://www.gov.scot/Resource/Doc/325663/0105011.pdf>
6. Taylor, K., & Lamoreaux, A. (2008). Teaching with the brain in mind. *New Directions For Adult & Continuing Education*, (119), 49-59. doi:10.1002/ace.305.
7. National Research Council.. *Rising above the gathering storm: Energizing and employing America for a brighter economic future*, Washington D.C. National Academies Press. (2007).
8. Osadchyi V. V., Osadcha K. P. Modern realities and trends of information and communication technologies development in education//*Information Technologies and Learning Tools*, 2015, V. 48, No 4, pp. 47-57.
9. Zaytseva T.: The Introduction of the Competence-based Approach in Educational Process of Training of Skippers. In: 12th International Conference on ICT in Education, Research and Industrial Applications: Integration, Harmonization and Knowledge Transfer, pp. 687-699. Kyiv, Ukraine, CEUR-WS, 1614, (2016).
10. Freeman, S., Eddy, S. L., McDonough, M., Smith, M. K., Okoroafor, N., Jordt, H., & Wenderoth, M. P. Active learning increases student performance in science, engineering, and mathematics. *Proceedings of the National Academy of Sciences*, 111(23), 8410–8415. (2014). doi:10.1073/pnas.1319030111
11. Rossini, F. A., & Porter, A. L.. Frameworks for integrating interdisciplinary research. *Research Policy*, 8(1), pp.70–79. (1979). doi:10.1016/0048-7333(79)90030-1.
12. Samchynska, Y., Vinnyk, M.: Decision Making in Information Technologies Governance of Companies. In:13th International Conference on ICT in Education, Research and Industrial Applications: Integration, Harmonization and Knowledge Transfer, pp. 96-110. Kyiv, Ukraine, CEUR-WS, 1844, (2017).
13. Kushnir N., Valko N., Osipova N, Bazanova T.: Experience of Foundation STEM-School. In: 13th International Conference on ICT in Education, Research and Industrial Applications: Integration, Harmonization and Knowledge Transfer, Volume II: Workshops. – ICTERI Kyiv, Ukraine, May 14-17, 2018., pp. 431-446, Access mode: [http://ceur-ws.org/Vol-2104/paper\\_241.pdf](http://ceur-ws.org/Vol-2104/paper_241.pdf)
14. Meeth L. R. Interdisciplinary Studies: Integration of Knowledge and Experience / Lois Richard Meeth //Change. – 1978. – № 10. – P. 6–9.



# Open Distance Learning for Teachers

Vladimir Kukharenko<sup>1</sup>[0000-0003-0227-5836], Tatyana Oleinik<sup>2</sup>[0000-0002-3771-4424]

<sup>1</sup>National Technical University “Kharkiv Polytechnic Institute” Kyrpychov Street 21, 61002  
Kharkiv Ukraine

kukharenkovn@gmail.com

<sup>2</sup>H. S. Skovoroda Kharkiv National Pedagogical University, Alchevskykh Street, 29, 61002,  
Kharkiv, Ukraine

t2.oleinik@gmail.com

**Abstract.** The purpose of the work is to demonstrate the results of the study on the role of open education for the system of professional development (advanced training) of distance and blended learning teachers. Research Laboratory of Distance Learning (RLDL) NTU "KhPI" offers teachers of educational institutions distance courses "Introduction into distance learning", "Distance education for managers", "Technology of design distance course", "Tutor's Practicum", "Blended learning", "Distance Course Expertise", "Content Curator". Teachers from universities, institutes of postgraduate pedagogical education and teachers of schools of Ukraine took part in the open distance courses since 2014, more than 2,400 students have been enrolled in courses.

There is presents research results concerning quality teaching and learning based on the educational technology portfolio at the KhNPU. More than 10 years of development formative assessment kit in the context of the integration of digital resources into teaching and later open educational resources into blended learning. It's no doubt, experience shows that at the initial stage of study a majority of students are interested preferably in the technical side of digital activity in the study. Experience showed they need time for the ready to consciously use the wide possibilities of a portfolio for the development of their independent evaluation, learning reflection, critical thinking, active research position and professional identity of the teacher. In this way, we have convinced the enhancement of the educational environment aimed at taking means of the digital portfolio should be recognized among the important conditions of the quality education improvement.

**Keywords:** OER. OEP, open online course, personal learning environment, ADDIE, tutor, digital portfolio.

## 1 Introduction

At the current stage, central planning and hierarchical decision making are too slow and ineffective, especially in difficult situations involving a large number of people. It's no doubt self-organizing teams are much more flexible than hierarchical ones [1],

but for first ones require active and engaging participants comparing to second ones, which drive opportunities for confidence and innovation.

The development of the network changes the professional activities of the individuals and the system of their training for work. The society moves into a networking era, where autonomy and the creation of a professional ecosystem become the main point. A professional ecosystem is a set of organizational and personal relationships as well as interacting elements (content, people, software, services, programs, etc.), which ensures the harmonious development of individuals.

We can see a majority of innovative organizations during this century were based on principles and frameworks that reflect the way of life of the human race in a networked society [2]. The first steps of a new network era are already determined through such values like subsidiary (that is solving problems at the level where they start) and network management, related supervision. We consider the new term "Wirearchy", it means a flow of power and authority, for example, a network of content curators which supports expert thinking at a high level, eliminates information overload, connects efforts and enables for experts to share wisdom and thoughtful.

The network era philosophy takes account of network education, which is still not fully clear, at the same time what kind of network education will exist is yet unknown, but open education is developing now. First of all, the open universities implement e-learning by MOOCs, Open Educational Resources (OER), and Open Educational Practice (OEP). The main dimensions of openness: transparency of communication and engagement.

The network era philosophy takes account of network education, which is still not fully clear, at the same time what kind of network education will exist is yet unknown, but open education is developing now. First of all, the open universities implements e-learning MOOCs, Open Educational Resources (OER), and Open Educational Practice (OEP). The main dimensions of openness: transparency of communication and engagement.

### **1.1 E-portfolio of teacher**

It should be noted that the use of open resources in education requires special attention to the issue of the improvement of educators' digital competence as persons who is capable to active life in a digital society (it's so-called "digital citizenship"). At the same time, it is extremely important to choose a reliable model of teaching and learning according to the goals of sustainable development. Of course, the key task of teacher training is related to the formation of an inquiry-based position for investigation on improving the quality of the digital educational environment that included, in particular, the open educational resources. Thus, first of all, it is sensible to organize a wide discussion about the peculiarities of implementing the model of the "community of practice", which combine efforts for constructive analysis of the quality of various tools of digital pedagogy.

Thus, in the system of measurement of educational achievements, over the last decade, we gradually move on to qualitative changes, in particular, to the implementation of educational portfolio technology [3, 4]. It focuses on the realization of the

tasks of informal assessment of persons' achievements, their support in reflection and self-improvement, which allows us to collaborate in inquiry-based learning that best suits their interests and abilities. It should be noted that for the creation of digital or web portfolio, the teachers get specialized means (for example, in social networks or web-applications), which facilitate flexible problem-solving placement and design of the portfolio themselves.

Undoubtedly, the distributed system of development of distance and blended courses at the pedagogical university has its own peculiarities connected with the quality of pedagogical experience of a large majority of participants, their interactions and educational researches. It is also necessary to take into account students' pedagogical training, which, with teachers' facilitating, contributes to their greater initiative to develop educational trajectory themselves. Thus, in situations of student-centred education, the portfolio allows the student to take responsibility to recognize the personal ways of professional development as well as the portfolio supports students in activating self-identification, self-confidence, and critical thinking.

## 1.2 Massive Open Online Courses

MOOCs (Massive Open Online Courses) are an important part of open education which becomes known in 2008. There are 2 kinds of distance courses: cMOOC (connective courses) and xMOOC (simplified courses).

xMOOCs is focused on the general training of students and, as a rule, do not provide credits of HEI system, but after a boom in 2011-2013 these courses have found a certain niche. One of the major weaknesses of xMOOCs, on experts opinion, is low impact: on average only 7% of students successfully finish ones, which conclude requests of diversity. It should be noted that the students' purpose of xMOOCs is different and does not always correspond with the authors' purpose.

cMOOC is network course with a variable structure focused on the high educational level of the participants, which has produced a personal learning environment and a personal learning network. Such courses are aimed at processing large flows of unstructured information for solving global problems.

According to several west educators' study [5] students who do not finish xMOOCs are often satisfied with their achievements that mean they have the personal meaning of success. Therefore, there is a need for new ways of supporting students in scheduling, achieving, reflecting, and students' authentic learning achievements rather than the planned educational results. It means that teachers have to create a learning environment in which a reflective (student's) model works and promotes the active making study plans, knowledge artifacts, and evaluation on student's capability. That model focused on the quality of students' activity and supporting ways of their competence.

There are important characteristics of students' behavior in network communities.

1. Consumption of knowledge. Students identify knowledge they need in the course-ware through self-learning in an educational environment, including other students, teachers and even people with whom they interact outside the course (friends, family, relatives' colleagues, etc).

2. Creation of new students' knowledge by themselves, designing new resources and expanding the provided resources. These new resources are a dynamic and an individual-oriented view on their knowledge.

3. Connections with people (including peers), who share interests or goals, as well as links with knowledge. It can be free, reciprocal or one-sided.

4. Implementation of new knowledge resources as official reports, so and informally (like reflections, ideas, ratings, and other content). These new resources can be used by other students and teachers.

### **1.3 Open Pedagogy**

Open education requires processes that are described by open pedagogy and open practice based on Open Educational Resources (OER). In the determination of open pedagogy by David Wiley in 2013 was given that an open pedagogy is a set of educational ways in the context of free access with permissions reuse, revision, remix, redistribution, and retaining) that are specific to the OER [6].

In accordance with the principles of open pedagogy, students will have an idea of the instructor's intentions in the offered course and see where the teacher's style does not fit their learning style. They will be able to develop a personal trajectory and perhaps adapt the previous students' open pedagogy (learning lines). It's no doubt the essence of pedagogy is the interaction of students and teachers, for this reason, pedagogy is not just educational ways, strategies, styles, but the relationship of authorities.

### **1.4 Open Educational Practice**

From the other side, open distance courses connect with Open Educational Practice (OEP) for participants [7], which includes the creation, use and reuse of OER, open pedagogy and open exchange of learning practices. It is a component of open education that embraces resources, tools and practices that use an open exchange framework to improve the access and effectiveness of education throughout the world. The level of understanding and acceptance of OEP among teachers of higher education is gradually increasing.

Open Educational Practice (OEP) expose four aspects for participants:

- balance of the protection of their privacy and openness;
- development of their digital literacy,
- assessment of their social learning,
- the challenge for traditional expectations of their roles.

The analysis has shown that teachers try to find of balancing the confidentiality and openness in using social and collaborative technologies at four levels: macro (global level), meso (community or network level), micro (individual level) and nano (interaction level). The differentiation of these levels has been useful in understanding the decision-making process around open practices.

At the macro level, people determine whether to participate in open exchange and networking. Some refuse this level, and those who take part in open practice should take into account the presence of the three following levels.

On the meso level, people determine who they want to share information with (for example, friends, colleagues, students, community groups of interests, the general public), as well as those with whom they do not want to share. At the micro level, people make a decision with whom exactly they will be divided and how. And at the nano level, people decide if they need to interact or share something specific: for example, post, tweet or retweet; whether to use a certain tag or hashtag; whether to follow or be a friend.

Open practice is not a one-time solution; this is a sequence of personal complex and nuanced solutions. People will always be motivated by personal values; their openness depends mutually on the structure, on culture and on social norms inside the institution. Open practice is characterized by the spirit, the way of democratic practices.

The relationship between OER and OEP can be complex, where the use of OER leads to an OEP. The growing use of OER can encourage individual educators to develop personalized learning networks (PLNs), through which they become aware of wider issues, connected with openness, including OEP. The use of OEP by faculty is complex, personal, contextual, and constantly debated.

## 1.5 Learning environment

According to Dewey, the fundamental starting point for learning is the goals and objectives of individuals, as well as learning that come according to the context of personality. However, social relations also play a central role in the socio-cultural approach and according to Wenger, Brown, Collins, and Duguid learning always relate to social practice. The actions of the individual occur in socio-cultural practice, which correlates the actions of other people (Leontiev), as a result, a variety of interaction forms between people become a central point to learning.

The realization of learning assurance depends on the improvement of an educational environment, where a unique educational culture is created. There are the most important components of the model for this learning environment [8]:

- learner characteristics (background knowledge, goal, level of digital literacy, diversity, learning context);
- content (content purpose, multimedia resources, structure, quality and depth, activity);
- skills (mental and practical actions, dialogue, goal-setting);
- learner support (feedback, tutorial, encouragement, autonomy, trust);
- resources (technology, facilitation, time management, assistance);
- assessment (essay, test, e-portfolio, project realization).

## 1.6 Obstacles

Information technology provides new opportunities: new learning experiences, new evaluation strategies, new development sequences, new places and graphics, as well as new partnerships. But when we integrate new information technologies to old methods, we can even reduce current results [9]. Now this is called the Baumol's effect [8].

The main reason why Baumol was right about education is that relations are of great importance here. Information technology can add some flexibility, but relationships require time and depend on the individuals involved in the learning process. This means that learning quality is unlikely to change in the near future.

Morag [11] analyzes the national digital training strategies in the Great Britain. They are based on that

- a free market is the most effective mechanism for organizing all aspects of human life;
- markets are self-regulated, state intervention is minimized and the market is at the optimal level;
- a person is a rational subject of the economy, therefore an open economy and a global free trade increase efficiency, quality and expand the choice of consumers.

Another key pillar is the assertion that market competition makes processes more efficient and, therefore, can reduce costs. However, there are a few significant evidences in support of these allegations. Digital technologies were mainly used to support, rather than transform, practice, often copying face-to-face learning strategies, automating administrative tasks, or promoting behavioral, content-oriented pedagogical models.

The analysis shows that digital technology is widely used in educational practice, but not all is as clear as it looks at first glance. Considering that in Ukraine, distance learning has not become massive one, attention should be paid to the methodology of distance learning and provision of staff.

RLDN NTU KhPI has conducted an analysis of the best international experience in modern teaching technologies and has created a series of open distance courses that should give the teacher an idea of the possible technologies of the future and prepare for their use. These courses are an example of ODC and OEP, based on world experience and adapted to the specifics of Ukraine.

## 2 Research Hypothesis

The new era needs new teachers training of which has to start at this time. The hypothesis of this study is that to provide a high level of training, the system of continuing education for distance learning teachers should be based on open education. Studying in open distance courses will facilitate teachers' understanding and feeling the benefits of open learning, molding open practice skills. Toward assurance a high scientific and advanced level of education, it is necessary to organize training content curators for masters, graduate students, faculty and researchers. The curriculum of

content curator is the basis for any researcher and teacher. In accordance with the goals of sustainable development society and the digital citizenship digital portfolio is one of the key components of a disruptive and qualitative model of conscious responsible learning.

### 3 Open Practice of RLDN NTU "KhPI"

The Research Laboratory of Distance Learning (RLDL) NTU "KhPI" offers distance education courses "Distance Learning for Managers" (DLM), "Technology of Design of Distance Course" (TDDC), "Tutor's Practicum" (TP), "Blended learning" (BL), "Expertise of Distance Course" (EDC), "Content Curator" (CC) for teachers of educational institutions and trainers of corporations (Fig. 1).

On the one hand, training courses should be realized in the following order: Content Curator, Introduction to distance learning (Distance learning for managers), Technology of design of distance learning, Blended learning, Tutor's Practicum, Expertise of Distance Course. On the other hand, teachers and educators can choose the course depending on their preferences.

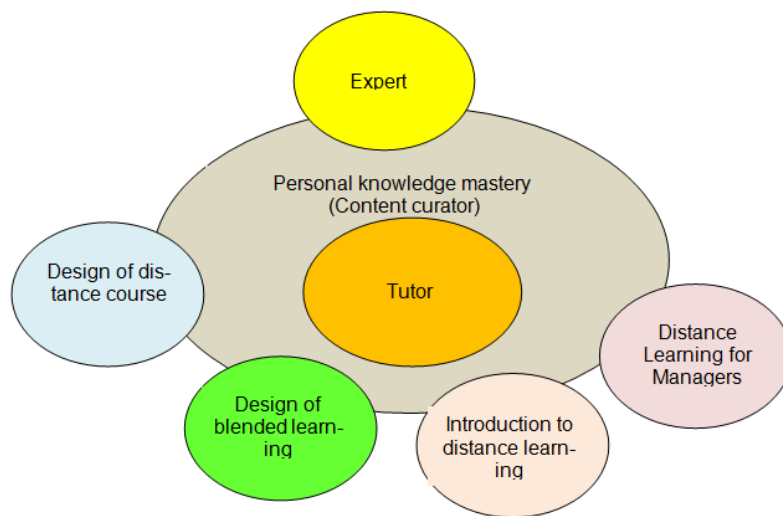


Fig.1. Open Distance Courses RLDL NTU KhPI

#### 3.1 Distance course «Content curator»

The "Content Curator" course, based on the manual [12], is aimed at a wide range of listeners from students to high-level professionals. The purpose according to the Bloom taxonomy for different categories of students may be different: the level of remembering and awareness – the collection, classification and exchange of links, the

level of application – the use of materials, the level of analysis – preparation of abstracts, the level of evaluation and creation – preparation of abstracts, analytical notes.

### **3.2 Distance course «Introduction into distance learning»**

The main purpose of this four-week course is to provide the teacher with the skills in distance education, to teach him to create an electronic course-resource (distance course for the delivery of informational materials, downloading individual tasks and passing tests), video tutorials on the basis of presentations and the simplest blended lesson. At the last week, the students study the search for professional information in scientific databases.

### **3.3 Distance course «Distance Learning for Managers»**

In four-week course review are considered the role of distance education in modern education, distance learning courses in higher education in Ukraine, distance learning process, evaluating students and distance learning course. Course participants create materials for a distance course "Introduction to the specialty" using the search skills in science databases and supervisory skills in the Moodle learning management system.

### **3.4 Distance course «Technology of Design of Distance Course»**

This is a constructivist teacher training course based on the manual [13], which goal is to help the teacher create a distance learning course using modern pedagogical and information technologies. Duration of training is 8 weeks with certificate of advanced professional development.

### **3.5 Distance course «Blended learning»**

The aim of the course author in this case is to determine the conditions of a synergistic effect in blended learning and to show that learning is a future in the development of valuable pedagogical technologies. This allows you to get new ideas for blended learning realization. Therefore, it is clear that the course did not foresee practical tasks, because the main objective is the exchange of experience and the development of a personal training network.

An open distance course «Blended Learning" is used in the educational process of the system of professional development of teaching staff from the second half of 2017. The main materials of the course are presented in the monograph [14].

### **3.6 Distance course «Tutor's Practicum »**

The curriculum consists of 7 topics that include communication, planning and rating activities of the student, the preparation of instructions and information materials, the



organization and conduct of discussions, the work of small groups [15]. Duration of training is 7 weeks.

### 3.7 Distance course «Expertise of Distance Course »

The program of the course "Distance Course Examination" is designed for six weeks. For the expert skills, the students trained the distance courses assessment and prepared reports.

## 4 Results of Training

There were teachers from universities, institutes of postgraduate pedagogical education and teachers of schools of Ukraine in the RLDL open distance courses. Learning outcomes are presented in Table 1.

**Table 1.** Statistics of the open distance courses of the PLDL

<b>Courses</b>	<b>Year</b>	<b>Registered</b>	<b>Studied</b>	<b>Graduated</b>
TP	2018	78	20	14
IDL	2018	94	30	14
TDDC	2018	150	44	23
TDDC -2	2018	38	14	6
BL-1	2017	94	35	20
BL-2	2017	228	60	23
IDL	2017	58	33	16
TDDC	2017	151	40	31
TP	2016	46	20	9
CC	2016	50	16	10
TDDC -1	2016	199	120	49
TDDC -2	2016	235	80	37
DLM	2016	131	30	14
TP	2015	74	18	13
TDDC	2015	81	30	2
CC	2015	90	34	17
TDDC	2014	186	70	12
TP	2015	60	15	2
CC	2014	130	62	23
CC -1	2013	50	18	15
CC -2	2013	140	83	20
<b>Total</b>		<b>2363</b>	<b>872</b>	<b>370</b>

All courses begin with the Forum "Introduction", where students are offered to talk about themselves and encourage them to exchange messages. All work reports are presented in forums, and the results of tasks are available to everyone. All questions to the tutor are placed in the forum of mutual help and students have the opportunity to help each other, which ensures the high activity of them in the course. In addition, weekly students complete a questionnaire for reflection, in which they can carry out self-assessment of their activities. This organization of the work of the students facilitates the creation of community practice in the course, which continues to exist after the course finishing.

The courses provide weekly webinars, which give an overview of the theoretical material of the course, analyse the performed work of the previous week and give recommendations for the practical questions of the current week. All webinars are recorded, which allows to view for the students at a suitable time. All creative problems of the course (presentation, infographics, and design projects) are evaluated by course students through the Moodle element "Seminar". The best works of the course are report on the final webinars (public awarding event).

The typical student looks up about 100-140 pages per month (25-35 pages per week), after finishing the course they continue to work with distance course materials during several months. Students like the variety of presentation of information in the course, a clear definition of the purpose of each week – the components of universal educational design. As a rule, after the completion of the educational process, the course is not closed, which allows the students to return to the processed material, to view the results of the group work. Registration for the course is also not closed and the course materials can be used by ordinary users of the network.

A questionnaire was conducted for graduates of open distance courses 2013-2018, 72 teachers have completed one, 33% teachers finished one course, 14% - 2 courses, 3% teachers - more than 5 courses. 34% of teachers did not receive a certificate of completion of the course, but they worked on theoretical material and performed separate tasks. These results show that the small percentage of those completing the course is not an indicator of the effectiveness of the course, because many of them continued distance teaching.

Besides questionnaire have shown that open distance courses change their teaching competence, in professional development sense, (45.7%), they create distance courses (60%), use in the educational process (67%), materials of the course are used to create a system of professional development in their organization (21.4%), study on the course change their career (18.6%).

## **5 Experience in Implementing the Digital Portfolio in KhNPU**

An electronic portfolio plays an important role in the training of a modern teacher, and at this stage of Ukrainian education, it's not used enough.

A portfolio is a kind of "diary" of individual achievements and works, which is a means of measuring level and quality of the development of abilities, through the

presentation of documented achievements, reports and various forms of self-esteem. A portfolio is an effective tool for visual data, helps to think about the features of the content and structure, organizes collections of qualitative characteristics for a clear and expressive presentation of individual achievements.

There are two guiding principles for the use of the portfolio:

- External principle: to familiarize other people (teacher, parents, friends) with the achievements of the student or group of students (for group portfolio) for providing them an appropriate assessment and facilitation of their activities, determining the levels of their qualification, etc.
- Internal principle: to develop the personality in conditions of improving reflexive activities, increasing motivation, evaluating results of activity for the development of more accurate imaginations about their own successes, disadvantages and opportunities.

As our experience shows, at the initial step of the portfolio implementation, the majority of students are willing active work with technology, but have not an experience of conscious evaluating, reflecting and correcting their own activities. At the same time, the portfolio facilitates increasing the personal responsibility, the creation of a mutual understanding of the review and constant re-evaluation of qualitative characteristics of the student's autonomy. In this way, it is very important for the teacher and students to discuss the expected results, the purpose of the evaluation, the evaluation criterions, and the specific methods in advance.

The main issues to be thoroughly considered are, firstly, the reasons for the implementation of the portfolio (in which way the portfolio is determined the correspondence of the objectives of the course and the personal development or market needs). Secondly, it is important to emphasize the ways and principles of the selection of materials. In this way, it is advisable to distinguish three types of portfolio, depending on the level of mastery of the specified teaching activity: 1) work portfolio or data one, 2) report portfolio or presentation one, 3) self-assessment portfolio and/or mutual evaluation one. Of course, according to this, the third kind of portfolio corresponds to the highest level of independence and consciousness in their development, based on a deep understanding of its advantages compared with the traditional learning approach.

In the future, the portfolio becomes a tool for establishing reliable feedback that promotes the development of certain aspects of the control and evaluation activities of the individual, namely, analysis of the peculiarities of the performed work, the definition of criteria and justifications for assessment, the search of directions the qualitative improvement.

Thus, it is expedient to distinguish the following functions of the portfolio:

- an informational function (that indicates the level of development of abilities, personnel changes, achievements, skills acquisition, skills and methods of activity);
- a motivational function (that encourages a transformation of educational processes and personal self-realization according to the assessment criteria [16, 21]);
- a developing function (that contributes to a creative approach to the implementation of tasks, development of abilities);

- a research function (that allows processing information, i.e. collect, analyze and generalize, determine the direction of further search);
- an educational function (that indicates the level of acquiring self-consciousness and adequate self-confident);
- a diagnostic function (that determines the causes of learning outcomes).

Undoubtedly, this leads to a change in the style of teaching; the role of a teacher in such a process is aimed at implementing a liberal interested adjustment and stimulation of educational activities that transform students into active individuals of study. In this way, there is a gradual transition from external management education to conscious self-management, when students are able to independently determine goals, content, ways of working, evaluation of the experience.

Summarizing, it should be noted that in the current time the portfolio becomes one key from the factors of a comprehensive definition of the quality of the educational process [14, 22-24] of the 21st century. In particular, our inquiry has shown students' achievements in self-regulation, cognitive monitoring, creative self-realization of students, conditioned by ability to goal-setting (ability to set ones, plan its achievements in accordance with its initial levels, nature own abilities, optimal pace), purposefulness (sustainability in achieving the goal), persistence in relation to (ability to formulate rules of activity, system of corresponding laws, to predict results), meaningful vision (the ability to represent graphical images), initiative, reflection (ability to analyze stages of individual and collective activity, use means, to find contradictions), ability to ask questions, rule-making means, the meaningful idea of the objects/processes being studied).

## 6 Resume

Open distance courses through the rapidly developed digital technology are constantly changing and expanding possibility educational landscape. The modern tendencies demonstrate if you can now distinguish three levels of courses: initial, professional and expert, and then there is neediness to initiate advanced level, which should continue courses for the design of distance teaching, blended learning and practicum in tutoring.

Our experience showed a teacher who is work in open educational space is comfortable with the understanding that a student is the main point of the learning experience. Thereby open education and pedagogy are determined as disruptive innovation and our researches are evidence for decreasing inequality of student's success. However, additional researches on quality professional development programs and courses are needed for teacher communities that will facilitate appropriate capacity building to overcome difficulties and barriers to successful adoption and dissemination blended learning across HEI.

It's no doubt many international events like CELT 2018, OER19, ICDE 2019 and organizations demonstrate significant of open movement, open distance courses will activate modern changes in the national digital education strategy as social justice in many countries as well as in Ukraine.

## References

1. Jarche, H.: Self-Organization is the Future. <http://jarche.com/2016/05/self-organization-is-the-future/#comment-279629> (2016) last accessed 2019/05/18
2. Jarche, H.: Organizing for the Network Era. <http://jarche.com/2017/06/organizing-for-the-network-era/> (2017) last accessed 2019/05/18
3. Oleinik, T.O.: The Use of Information and Communication Technologies for Assessing the Level of Educational Achievements of Students of the University. *Information technologies and teaching means* 42(4), 85–93 (2014).
4. Scully, D., O’Leary, M., Brown, M.: The Learning Portfolio in Higher Education “A Game of Snakes and Ladders”. Dublin City University, Centre for Assessment Research, Policy & Practice in Education (CARPE) and National Institute for Digital Learning (NIDL). Dublin (2018).
5. Littlejohn, A.: Learning through the Open Creation of Knowledge <http://littlebylittlejohn.com/open-knowledge/> (2018), last accessed 2019/05/18
6. What is Open Pedagogy?  
[http://wikieducator.org/Foundation\\_Skills/Principles\\_and\\_practices\\_of\\_open\\_online\\_pedagogy/What\\_is\\_open\\_pedagogy%3F](http://wikieducator.org/Foundation_Skills/Principles_and_practices_of_open_online_pedagogy/What_is_open_pedagogy%3F), last accessed 2019/05/18
7. Cronin, C.: Openness and Praxis: Exploring the Use of Open Educational Practices in Higher Education. *International Review of Research in Open and Distributed Learning*. 18(5). <http://www.irrodl.org/index.php/irrodl/article/view/3096/4301> (2017)
8. Bates, T.: Culture and Effective Online Learning Environments. <http://www.tonybates.ca/2016/05/15/culture-and-effective-online-learning-environments/> (2016), last accessed 2019/05/18
9. Vander Ark, T.: How and Where EdTech Will Help <http://www.gettingsmart.com/2018/01/how-and-where-edtech-will-help/> (2018), last accessed 2019/05/18
10. Baumol's Cost Disease Wikipedia,  
[https://en.wikipedia.org/wiki/Baumol%27s\\_cost\\_disease](https://en.wikipedia.org/wiki/Baumol%27s_cost_disease), last accessed 2019/05/18
11. Morag, M.: The Complicity of Digital Technologies in the Marketisation of UK Higher Education: Exploring the Implications of a Critical Discourse Analysis of Thirteen National Digital Teaching and Learning Strategies. *International Journal of Educational Technology in Higher Education*. (2018), doi:10.1186/s41239-018-0093-2
12. Kukhareno, V.M., Glavcheva, Yu. M., Rybalko, O.V.: Content Curator: tutorial manual / Editor Kukhareno V. M. Kharkiv, "Miskdruck", NTU "KhPI", (2016)
13. Bykov, V.Yu., Kukhareno, V.M., Syrotenko, N.G., Rybalko, O.V., Bogachkov, Y.M.: Technology of Development of a Distance Course / Ed. Bykov V.Yu. and Kukhareno V.M. Kyiv, Millennium, (2008)
14. Kukhareno, V. M., Berezenska, S. M., Bugaichuk, K. L., Oleinik, N.Yu., Oleinik, T.O., Rybalko, O.V., Syrotenko, N.G., Stolyarevska. A.L.: Theory and Practice of Blended Learning: Monograph / Ed. Kukhareno V. M. Kharkiv, "Miskdruck", NTU "KhPI", (2016)
15. Kukhareno, V.M., Syrotenko, N.G., Molodyh, G.S., Tverdokhlyevova, N.E.: Distance learning: Textbook / Ed. Bykov V.Yu. and Kukhareno V.M. Kyiv, Millennium, (2005)
16. The Technology Integration Matrix. <https://fcit.usf.edu/matrix/matrix/> (2019).
17. Conole, G.; Brown, M.: Reflecting on the Impact of the Open Education Movement. *Journal of Learning for Development*, 5(3) (2018). <http://www.jl4d.org/index.php/ejl4d/article/view/314/346>.

18. Laurillard, D.: Teachers Designing for Lifelong Learning in a Digital World <http://konferanser.hil.no/icdellls2019/presentations/> (2019), last accessed 2019/05/18
19. Brunton, J., Brown, M., Clinch, G., Costello, E., Farrelly, T., Gilligan, J., Murphy, A.: 'Teaching for Transitions': Reflecting on Three Nationally Funded Projects That Developed Digital Tools to Facilitate Transitions into Higher Education. In: Proceedings of EADTU Conference "Online, Open and Flexible Higher Educaiton" pp. 661-673 (2016). <https://conference.eadtu.eu/download2415>
20. Kähkönen, E., Kommers, P., Sutinen, E. and Tedre, M.: How does the Web add Value to Community Building? International Journal of Web Based Communities, 1(1), (2019), <http://www.inderscience.com/browse/index.php?journalCODE=ijwbc>
21. Gerstein, J.: The Other 21st Century Skills: Educator Self-Assessment. <https://usergeneratededucation.wordpress.com/2015/01/16/the-other-21st-century-skills-educator-self-assessment/> (2015), last accessed 2019/05/18
22. Oleinik, T.: Course "Critical Thinking" for Students and Teachers of Universities. Pedagogy and Psychology. OBC, Kharkiv, 22, 135-140, (2002)
23. Oleinik, T., Kravchenko, N.: Technology of Critical Thinking Development in High School. Pedagogy and Psychology. KhNPU, Kharkiv, 19 (3), 83-85, (2001)
24. Prokopenko, A., Oleinik, T., Beregna, S., Shcheblykina, T.: Improvement of the Teacher Training Quality. In: Proceedings of EADTU Conference "Online, Open and Flexible Higher Educaiton", pp. 416-439, (2016), <https://conference.eadtu.eu/download2415>

# The Technique to Evaluate Pupils' Intellectual and Personal Important Qualities for ICT Competences

Svitlana Lytvynova<sup>1</sup>, Oleksandr Burov<sup>1</sup>, Olga Slobodyanyk<sup>1</sup>

<sup>1</sup>Institute of Information Technologies and Learning Tools

ayb@iitlt.gov.ua

**Abstract.** The paper presents the ICT technique for assessment of schoolchildren abilities, intellectual and personal important qualities for ICT competences formation, as well as research in this domain. The results of comparative analysis of abilities of pupils with mathematical and IT abilities in non-profiled schools in relation to “average” abilities are presented after results of pilot study. Examples of methodical developments are given. Some expected and unexpected results of the experimental research are discussed.

**Keywords:** learning environment, intellect, personality, abilities, high school children.

## 1. Introduction

At present, our lives are being built more and more around digital networks. The cyberspace becomes the general environment of a human life and activity. F.e., Internet of Things (IoT) entered our life, about 13 different devices are on average in each house (computers, laptops and smartphones, routers, IP cameras, digital video recorders, etc.); in 2018, more than 30 billion IoT-devices around the world were connected to the Internet.

New challenges of time and new directions of society development - Society 4.0, Education 4.0, penetration of the latest technologies into all spheres of life – need digital competences for everybody, not only specialists [1], because he/she becomes the element of the general intellectual capital [2]. As a result, the importance of information and communication technology (ICT) for education and training [3] requires the ability to process a large amount of information, to analyze the data obtained and provides it correctly using the appropriate and modern ICTs, including in synthetic environment [4], when the ability to work in on-line and off-line modes, as well as computer modeling is needed [5].

The **purpose** of the article is to analyze intellectual and personal important qualities needed for ICT competences of high school students in general (non-profiled) schools.

## 2. Related Work

Specialists in psychology and pedagogics articulate the necessity of forming a person at the beginning of the XXI century in both formal and informal education [6] with such professional skills as: informational literacy, inventive analytical thinking, quick search and processing of information, innovative thinking style, effective communication, project and team work, problem solving, ability to take responsibility, high productivity, and life competencies [7]. To date, special attention is paid to expand the digital competence by not only professional skills, but understanding threats from the digital environment [8], with special attention to information security culture [9] and recognition of new nature and features of today's networks [10]. This corresponds to the general requirements to IT skills [11], but it is needed to pay more attention to general cognitive abilities of a human [12] for most professions with regards to importance of the human intellect [13] and possibility to measure it in accurate manner [14], as well as a human personality features [15] that form a human as a specialist and as a workforce, and that should be formed effectively when using computer modeling in class work [16].

## 3. Method

In a screening study with the help of the ICT developed, and in order to identify the dominant fields of intellectual activity of high school students (grades 8-11), it was applied a methodology [17] and technique of psychological test performance, with subsequent analysis of data obtained. The *tests* included:

*M. Lüscher color and associative test* (pairs comparison method); purpose of use is an assessment of stress, balance of psychological qualities; recorded parameters are as follows: total deviation (CO), Shiposh coefficient (VC), stress level (C), working capacity (RP), heteronomy-autonomy (GA), concentricity-eccentricity (KE), balance of personality traits (BL), the balance of the vegetative system (BV).

*Myers-Briggs Type Indicator* (MBTI); the purpose of use is an introspective questionnaire to indicate differing psychological preferences in how people perceive the world around them and make decisions an assessment of the ability to certain activities and individual properties of communication; traditional indices of an individual typology estimation according to the Myers-Briggs methodology are recorded based on the evaluation of the prevailing signs on the 4 criterion scales: extraversion E - introversion I (orientation of consciousness), intuition N - sensory S (way of orientation in a situation), thought/judgment J - perception P (method of preparation of decisions), thinking T - experience F (decision-making); in our research, we used quantitative evaluation of subjects' report on each scale, where each value was calculated as a sum of positive answers to the appropriate question.

*Modified Intellectual Structure Test after R. Amthauer* (TCI); purpose of the test use is a definition of the level of development and structural features of intelligence, adfa, p. 2, 2011.

© Springer-Verlag Berlin Heidelberg 2011



as well as attention, memory; the following subtests are used (the brackets show the corresponding structural component of the intelligence):

- LS (testing of language, ability to formulate judgments),
- GE (conceptual intuitive thinking),
- AN (combinatorial abilities, mobility and ability to switch thinking),
- RA (ability to solve practical computational problems character),
- ZR (logical and mathematical thinking),
- FS (figurative synthesis),
- WU (spatial thinking),
- ME (memory, attention).

The values of the structural components of intelligence were calculated as the sum of the correct answers for each subtest, the values of verbal (VI) and nonverbal (NI) intelligence were calculated as a sum of values, respectively, LS, GE, AN, ME and RA, ZR, FS, WU. The overall IQ score was calculated as the sum of values VI and NI multiplied by the correction factor 1.462 .

The resulting primary data was entered into a spreadsheet for further analysis. Test results were not personified, but were taken into account for each course separately.

The data analysis included:

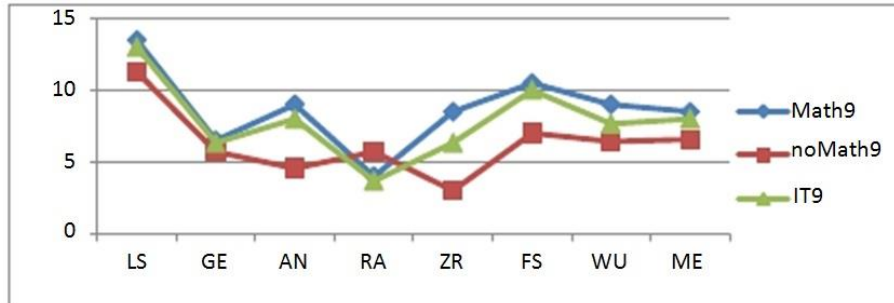
- comparative evaluation of indices measured;
- visualization of these data;
- comparative analysis for three groups of pupils: with higher math abilities (g1), with higher IT abilities (g2) and general group (without abilities), according to teachers' marks (g3);
- stepwise discriminant analysis to reveal intellect and personality structure indices for comparable groups.

*Subjects.* In order to verify the effectiveness of the methodology, 43 pupils of 8<sup>th</sup>, 9<sup>th</sup> and 10<sup>th</sup> grades of common school (non-profiled) were involved in the testing.

#### **4. Results and Discussion**

According to our prior results, intellect value of high school pupils of math and IT profile is significantly higher than in schools in average [18]. But schoolchildren participated in those research represented a selective sample, and their IQ was higher than 130, as a rule. Results of the intellect measurement in current research demonstrated that IQs in grade 9 was 102, 92, 76 (by groups g1, g2 and g3). Accordingly, IQs in grade 10 were 105, 101 and 80, i.e. a little bit higher, but significantly less than in pupils of profile schools. We strongly believe that it could be explained by “blurring” of classes because of children with different abilities.

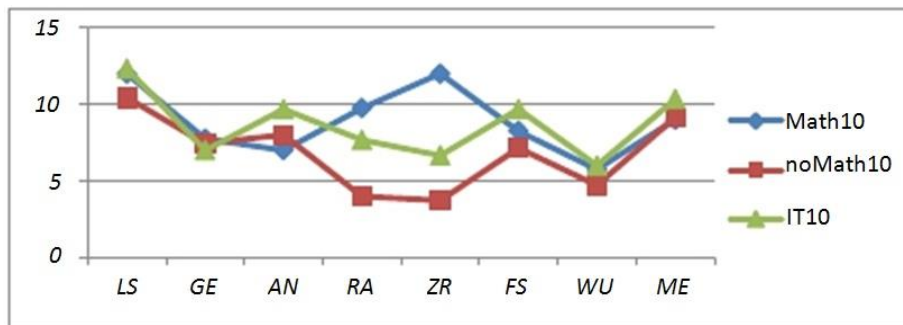
Important characteristic of the intellect development is an intellect structure. According to the data known intellect framework impacts the creativity, very important feature of IT-competence. From the data obtained, such a structure of three groups analyzed in the research is relatively expected: higher for pupils of the g1 group and less values for g3 (Fig. 1).



**Fig. 1.** Intellect structure of the 9<sup>th</sup> grade pupils.

However, unexpected result has been revealed in RA component: ability to solve practical computational problems character. Pupils of g1 and g2 groups coped with that task better.

At the same time, in 10<sup>th</sup> grade results of the test performance were as expected (Fig.2).



**Fig. 2.** Intellect structure of the 10<sup>th</sup> grade pupils.

It is necessary to highlight that personality structure of the pupils of the 9<sup>th</sup> grade was practically the same for pupils of g1 and g2 groups (Fig.3), significantly different from group g3, especially in decision-making on the base of emotions and introversion.

But 10<sup>th</sup> grade pupils' personality structure was similar for all three groups, though mindset (thinking T index) demonstrated "average" pupils (Fig.4). That result could be explained by their less formalized thinking and being ready for activity with "open mind".

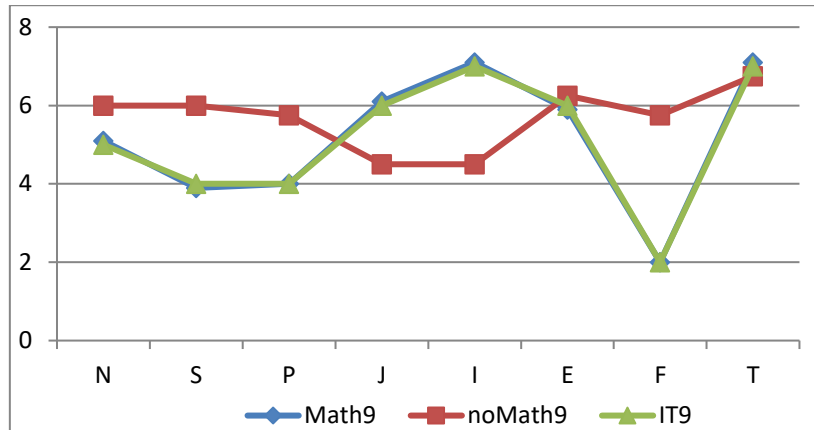


Fig. 3. Personality structure of the 9<sup>th</sup> grade pupils.

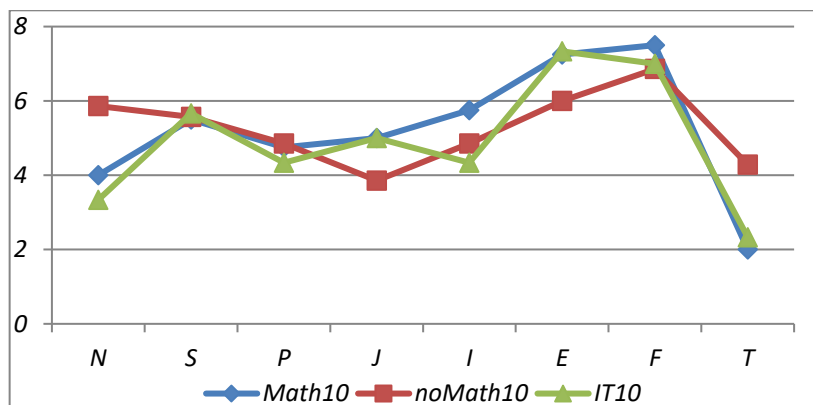


Fig. 4. Personality structure of the 10<sup>th</sup> grade pupils.

The next step of analysis has been carried out in relation to reveal what particular components of the intellect and personality could be used to differ groups under research, first of all g1 and g3, because they demonstrated not always expected tendencies. To solve that task it was used forward stepwise discriminant analysis to find which indices could describe those groups more reliable.

Significant indices from 27 intellect, personality and nerve balance features were included into the discriminant model step-by-step according to the criteria of the highest value of D<sup>2</sup>-Makhalanobis factor (D<sup>2</sup>-M). In this case, some additional values were calculated: group determination's coefficient of accuracy (DCA1 and DCA3, respectively), reliability coefficient for discriminant function (RDF). That technique was propose and developed by one of co-authors for data analysis in emergent industries [19].

The consequence of indices included into the discriminant model demonstrates that sensory S (way of orientation in a situation) and RA (ability to solve practical computational problems character) differs math-oriented pupils and others in the best way (Table 1). The next important indices (VC and BL) are associated with vegetative balancing of the human central nerve system and specify the group g3 practically with the reliability 100% (discriminant factor equal 1.0). But this is not enough to specify g1 pupils who are described good when the model includes intellectual thinking indices ZR and T.

**Table 1.** Building of the discriminant model for 10<sup>th</sup> grade pupils' g1 and g3

Step	Index	D <sup>2</sup> -M	DCA1	DCA3	RDF
1	S (sensory)	5.87	0.5	1.0	0.8
2	RA (ability to solve practical computational problems)	11.95	0.75	0.83	0.8
3	VC (Shiposh' coefficient)	18.95	0.75	1.0	0.9
4	BL (balance of personality traits)	23.12	0.75	1.0	0.9
5	FS (figurative synthesis)	29.78	0.75	1.0	0.9
6	ZR (logical and mathematical thinking)	30.36	1.0	0.83	0.9
7	T (thinking)	30.40	1.0	0.83	0.9

The next steps after first 7 were not constructive, because accuracy and reliability of the groups' determination could not increase. In other words, pupils with mathematical and non-mathematical abilities in common classes can be separated by only 7 significant indices of: personality (sensory and thinking), intellect (ability to solve practical computational problems, figurative synthesis, logical and mathematical thinking), as well as personality balance (Shiposh' coefficient and balance of personality traits) with quite high accuracy and reliability.

This result demonstrated that schoolchildren of high school can have some clearly determined features even in common (non-profiled) schools that could be revealed, if using the appropriate ICT to reveal such "hidden" abilities, usually not determined in classroom.

At the same time, the results of such an analysis articulated that pupils with math and IT abilities have similar features in comparison with rest pupils, but all three set of test indices (intellect structure, psychological preferences and vegetative balance) are important in formation of psychophysiological portrait of studied g1, g2 and g3 groups. The question that is discussed in psychological literature up to now deals with the relationship of vegetative features and psychological preferences. In our field of interests, this relates to the specifics of IT-able pupils in high school. The analysis of such a relationship could not give a positive answer, i.e. such research should be continued, maybe on the biggest cohorts.

## 5 Concluding Remarks and Future Work

The technique proposed for assessment of “hidden” abilities of schoolchildren for the high non-profiled schools and realized as a special ICT can be used in common education practice. Indices (important to define math- and/or IT-abilities of pupils) include elements of the intellects structure, personality structure and balance of psychological qualities.

Problems that require further research in this area: extended research to collect more wide set of data from profiled and non-profiled schools with math and IT teaching.

## References

1. Digital Competences Framework for EU citizens. <https://ec.europa.eu/social/main.jsp?catId=1315&langId=en>  
[http://publications.jrc.ec.europa.eu/repository/bitstream/JRC106281/web-digcomp2.1pdf\(2018\)](http://publications.jrc.ec.europa.eu/repository/bitstream/JRC106281/web-digcomp2.1pdf(2018)).
2. Strategies for the New Economy Skills as the Currency of the Labour Market. Report. World Economic Forum. 22 January 2019. <https://www.weforum.org/whitepapers/strategies-for-the-new-economy-skills-as-the-currency-of-the-labour-market> Davos (2019).
3. Gonzalez, Heather B. & Kuenzi, Jeffrey J.: Science, Technology, Engineering, and Mathematics (STEM) Education: A Primer, report, August 1, 2012; Washington D.C. <https://digital.library.unt.edu/ark:/67531/metadc122233/>: accessed March 25, 2019
4. Pinchuk, O. P., Lytvynova, S. G., Burov, O. Yu.: Synthetic educational environment – a footpace to new education (in Ukrainian). In: Information Technologies and Learning Tools, vol. 4, # 60, pp. 28-45 (2017). <https://journal.iitta.gov.ua/index.php/itlt/article/view/1831>.
5. Lytvynova, S. G.: System of computer modeling objects and processes and features of its use in the educational process of general secondary education (in Ukrainian). In: Information Technologies and Learning Tools, vol. 2, # 64, pp. 48-65, (2018). <https://journal.iitta.gov.ua/index.php/itlt/article/view/1831>.
6. Morze, N., Spivak, S.: Informal learning as an integral part of e-learning environment of the modern education. *E-learning and Intercultural Competences Development in Different Countries*. Monograph. Scientific Editor Eugenia Smyrnova-Trybulska. Katowice – Cieszyn (2014).
7. Education and Training 2020 Work programme Thematic Working Group 'Assessment of Key Competences' Literature review, Glossary and examples. - European Commission, Directorate-General for Education and Culture, November, 2012. – 52.
8. Burov O.Ju.: Educational Networking: Human View to Cyber Defense. Institute of Information Technologies and Learning Tools 52, 144--156 (2016).
9. Glaspie H.W., Karwowski W.: Human Factors in Information Security Culture: A Literature Review. In: Nicholson D. (eds) *Advances in Human Factors in Cybersecurity*. AHFE 2017. *Advances in Intelligent Systems and Computing*, vol 593. Springer, Cham (2018).
10. Burov, O.: Virtual Life and Activity: New Challenges for Human Factors/Ergonomics. In Symp. Beyond Time and Space STO-MP-HFM-231, STO NATO, 2014, pp. 8-1...8-8.

11. Alison, Doyle: List of Information Technology (IT) Skills. Retrieved from <https://www.thebalancecareers.com/list-of-information-technology-it-skills-2062410>. (15.08.2018).
12. Veltman H., Wilson G., Burov O.: Cognitive load. In: NATO Science Series RTO-TR-HFM-104, Brussels, 97–112 (2004).
13. Sauce, B., & Matzel, L. D.: The paradox of intelligence: Heritability and malleability coexist in hidden gene-environment interplay. *Psychological Bulletin*, 144(1), 26-47 (2018).
14. Hyde, G., Knocker, G.: Made to measure Intelligent Personality Assessment. Research Report. [https://media.bitpipe.com/io\\_10x/io\\_102267/item\\_465972/ProfileMatch%20Research%20Report.pdf](https://media.bitpipe.com/io_10x/io_102267/item_465972/ProfileMatch%20Research%20Report.pdf) (2018).
15. Christopher J. Hopwood, Johannes Zimmermann, Aaron L. Pincus, and Robert F. Krueger: Connecting Personality Structure and Dynamics: Towards a More Evidence-Based and Clinically Useful Diagnostic Scheme. *Journal of Personality Disorders: Vol. 29, Special Issue: Personality Dynamics Underlying Personality Disorder and Related Psychopathologies*, pp. 431-448 (2015).
16. Slobodyanyk, O. V.: Computer modeling as a means of activating cognitive activity in physics classes. *Proceedings, Iss. 169, Series: Pedagogical Sciences. Kropyvtytskiy: RVV KPDU by name V.Vinnytchenko*, 140 -144 (2018).
17. Burov, O.Yu., Rybalka, V.V., Vinnik, N.D., Rusova, V.V., Pertsev, M.A., Pleksenkova, I.O., Kudryavchenko, M.O., Sagalakova, A.B., Chernyak, Yu.M.: Dynamics of development of intellectual abilities of gifted personality in adolescence. *Ukraine, K.: Information Systems* (2012).
18. Burov, O.: Profile Mathematical Training: Particular Qualities of Intellect Structure of High School Students. *Physical-mathematical education, Issue 1 (15)*, 108-112 (2018)
19. Burov A.: Psychophysiological maintenance of operators' work. *Information and control systems for railway, #6*, 32-34 (1999).

# The Method for Forming the Health-Saving Component of Basic School Students' Digital Competence

Yuliia Nosenko<sup>1</sup> [0000-0002-9149-8208], Alisa Sukhikh<sup>2</sup> [0000-0001-8186-1715]

<sup>1</sup> Lead Researcher of Department of Cloud-Oriented Systems of Education Informatization, Institute of Information Technologies and Learning Tools of NAES of Ukraine, Kyiv, Ukraine  
Luckyjue@ukr.net

<sup>2</sup> Junior Researcher of Department of Cloud-Oriented Systems of Education Informatization, Institute of Information Technologies and Learning Tools of NAES of Ukraine, Kyiv, Ukraine  
AlisaSukhikh@school11.onmicrosoft.com

**Abstract.** The article describes the method for forming the health-saving component (HSC) of basic school students' digital competence that involves the purposeful acquisition of the ability to health-saving use of ICT in educational process. The basis for named method implementation is the author's training course, covering 12 academic hours and designed for 5-9 grades classes (10(11)-15 years old students). The training course can be conducted within the compulsory subjects or electives in groups of up to 15 students. In the article the named course tasks are defined, the content units, principles and methods are represented. The recommendations for the final control (group project) are given. An empirical study showed that in the experimental group that studied under the author's method, the number of students with a low level decreased significantly, while the number of students with average and high levels of HSC increased. These results are much ahead of those obtained in the control group. Consequently, the results of the experiment showed the effectiveness of the author's method for forming HSC of basic school students' digital competence.

**Keywords:** Basic School Students, Health-Saving Component, Digital Competence, ICT, Method, Experiment.

## 1 Introduction

Adjusting to current social demands, educational system of Ukraine has sustained remarkable changes during last years: updating of regulatory framework, content and educational standards, implementation of hardware devices that has facilitated expansion of the scope of teaching materials, appearing of new facilities for pedagogical systems upgrading. Besides the obvious advantages, modernization of educational domain is related to a range of factors, which produce a deleterious effect on psycho-physical state and health of rising generation: informational overloads, stress-

---

<sup>1</sup> Basic school in Ukraine covers 5-9 grades and involves 10(11)-15 years old students.

generating situations, hypodynamy, insufficient natural lighting etc. All these factors create significant tension for child organism, which alongside with other negative factors leads first to diseases, functional disorders and later to development of organ pathology.

Major and one of the most forward-looking part of our society is constituted by adolescents. Adolescence is regarded as one of the most crucial periods in human life. The specificities of this age determine a specific state of organism, full social vulnerability, dependence of social environment's influence at biological and social and psychological levels. According to World Health Organization, deterioration of living conditions and decreasing of social stability in society determine growth of stress state in teenager population more than in other social strata, what leads to increase in disease. According to National Academy of Medical Sciences of Ukraine (as of 2016) adolescents display significant health deterioration during the period of their school studies. According to Ministry of Health of Ukraine (as of 2017) during the last years, the state of adolescents' health remains unsatisfactory with a negative tendency to deterioration.

One of the factors of influence on students' health state is use of modern ICT. Analysis of the results of studies in medicine, ergonomics, psychology, pedagogy (Balanskat A. [1], Dymova A. L. [2], Hainsworth A. [3], Hakala P. T. [4], Hun H. E. [5], Muhametzyanov I. Sh. [6], Polka N. S., Platonova A. H. [7]) proves that major part of negative consequences (such as reduction of long-term working capacity, decrease of efficiency and quality of learning, cognitive overload, growth of diseases of locomotor system, impairment of sight, etc.) are mostly determined by «human factor» and related to non-observance of ergonomic and pedagogic norms. Some researchers point out the risks of the harmful effects of ICT on the physical and mental health of children and adolescents, which is related to psychological overload, ergonomically unwanted use of equipment and furniture, violation of time standards for using ICT, etc. (Ciccarelli M. [2], Hainsworth A. [3], Hakala P. T. [4], Zlaman-ski R. [13]).

That is why of the most dominant current problems is development of scientific and methodological foundation for health-saving use of ICT, formation and development of the relevant competences of educational process participants.

**The purpose** of our study is to substantiate the method for forming the health-saving component of basic school students' digital competence.

## **2 The presentation of main results**

### **2.1 A forming the health-saving component of digital competence as a main condition for healthy use of ICT in teaching basic school students**

Our study [6; 10; 11, etc.] allowed to establish a suggestion that the foundation for health-saving use of ICT in basic school (BS) educational process is systematic and dedicated formation of health-saving component (HSC) of BS students' digital competence. We define it as student's ability to apply consciously a range of developed measures of methodologically reasoned and safe use of ICT in educational process.



It was defined, that knowledge, abilities and skills of health-saving use of ICT should be considered within the scope of digital competence as one of its components, as for:

- Effective work with ICT is not possible without knowledge of observing the norms and requirements on it safe health-saving use;
- Formation of competence about health-saving use of ICT has to precede the actual start of their application in educational process;
- Development of competence about health-saving use of ICT has to be exercised hand in hand with studies with use of ICT during the whole period of studies and mainly in the process of studying IT-disciplines.

Formation of HSC of digital competence of BS students provides their acquisition set of relevant knowledge, abilities and skills, persuasions and motivation aimed at preservation of physical and psychological well-being and health while use of ICT.

We have defined main components of HSC of digital competence structure:

1. *Value and motivational component*, which embraces a system of persuasions, value orientations and motivation of the person in preservation of his/her own health, interests and mindsets on implementation of health-protection measures.
2. *Cognitive component*, which envisages systematic acquisition of corresponding skills on safe exploitation of ICT in educational process: content of safety regulations of work with computer facilities; nature of potential threats while working with ICT; duration of recommended time limits of work with computer; ways of minimization of deleterious effects of computer techniques on organism etc.
3. *Operational and functional component*, which embraces ability to apply theoretical knowledge of health-saving use of ICT on practice, and envisages following of security regulations of work with computer; observing time limits of work with computer; ability to adjust his/her working place according to individual specifics and needs; self-analysis of own state before, during and after work with computer; self-control and self-regulation of correct posture in the working process; regular breaks on physical warm-ups to relieve the fatigue sustained by eyes, muscles, joints etc.

The degree of HSC advancement is attested by advancement of each it's component.

To evaluate the situation with health-saving use of ICT at lessons in BS a survey of 351 persons was conducted: 246 students from 5th to 9th grades and 105 teachers [11]. In particular, it was found that:

- Teachers and students regularly use ICT in educational process, specifically such devices as personal computer, laptop, tablet, e-book;
- Valid time limit recommended by state sanitary and hygienic regulations is not known to most of students and not observed by them. First, it proves the absence of adults' relevant control, and second, the low current level of HSC of digital competence of interviewed teenagers;
- There are no coordinated actions of parents and teachers, what generates a collision: if time and conditions of work with computer is strictly regulated in with san-

itary and hygienic standards at school, at home time limits are not regulated and could last 3 hours and more (!). We believe that defaults of coordination between the actions of teachers, parents and students could be liquidated by implementation of systematic teaching and education activities.

The above-mentioned activities require development of relevant methodical standards for forming HSC of BS students' digital competence.

## **2.2 The method for forming HSC of BS students' digital competence**

While planning and exercising of health-saving teaching activity with BS students it is essential to take into consideration psychological specificities of their studies:

- Choose of methods and forms of studying, which emphasize teenagers' growing independence and their self-sufficiency;
- Formation of new motivations for studying: erudition, aspiration to self-fulfillment, needs for self-establishment and self-improvement;
- Knowledge become a value and allow to gain a certain status among their peers;
- Orientation on independent search of new knowledge;
- Accompaniment of the process of learning with intellectually filled emotions and selective approach to learning, based on the student's interest;
- Transforming grade into motivational and stimulating mechanism, which makes a benefit for work and defines a student's status in a team;
- Necessity of communication, participation in group activities, and self-recognizing.

As for school studies make a considerable part in teenager's life, it's important for teachers to pay special attention to those types of education activities, which are able to reveal their independence, responsibility and ability for self-organization, which makes them more adult according to their personal understanding, stimulates to interaction, expressing and justification of their own points of view, and self-representation. Independent forms of classes, where democratic teaching style persists, and teacher acts as tutor and counselor, gain more attraction in students' eyes.

It was proven as efficient to apply such interactive methods of studying as training exercise, business game, brain storming, problematic discussion, group studying and project activity etc., which strengthen teenagers' motivation, stimulate their intellectual and emotional activity, engage them to group creative activity and facilitate their ability to reveal their activeness and leadership.

Development of such psychological functions as attention, reflection, willpower and ability of self-management makes a ground for effective formation of HSC of digital competence. In this regard, in order to form HSC of BS students' digital competence it is useful to organize special educational events, which would take in consideration the specific features of this age category. Thus, we have designed a training course «Health-saving use of ICTs».

*The purpose of the course* is constituted by forming HSC of BS students' digital competence, particularly in acquisition and development of health-saving use of ICT, values and persuasions about usefulness of observing necessary measures and restrictions, motivations to do it.

*Objectives of the course:*

- Create in students notions of health, health-saving, develop in them a careful attitude to their health as one of the most important life priorities;
- Create in student a concept of information technology, different kinds of ICTs, their differences, their disadvantages and advantages, ways of their use for different studying, professional and everyday life tasks;
- Form awareness of risks of incorrect use of ICT and its negative consequences;
- Develop a motivation to safe, health-saving exploitation of ICT, persuade students it's necessary to protect a healthy sight, locomotor system, long-term working capacity with use of ICT;
- Form knowledge and skills of creating a safe working environment while use of ICT;
- Form habits of taking preventive measures on protection of health of sight, back and joints, correct posture and long-term working capacity while work with ICT;
- Create in students an idea of computer addiction as destructive phenomenon, dangerous for health, disease of XXI century; provide them with recommendations about ways of its prevention;
- Create in students an idea of cyberbullying as negative and dangerous social phenomenon, give them recommendations about the ways to avoid it.

The course is designed for 12 lessons and lasts 12 academic hours<sup>2</sup>. The course is planned to be taught in grades from 5th to 9th.

The course could be taught as integral part of IT-subjects or health-protect-subjects, as well as elective classes. It would be advisable to teach classes in subgroups of students of average number 10-12 persons, up to 15 persons at maximum.

While planning this work a teacher should be guided with the following *principles*:

- Scientific principle – it determines a necessity to teach students contemporary scientific knowledge. It's appropriate to involve students in independent definition of topical problems and search for ways of their solution;
- Principle of systematicness and coherence – consistency in teaching and retention of learning material, consistent and continual transition from simple to difficult (rule of “concentric circles”) with taking to consideration the subject's logic and students' age specificity;
- Principle of consciousness and activity – based on understanding of particularities and patterns of people's cognitive activity, and realizing of the fact that knowledge couldn't be transferred, but could be only gained by conscious and active work;
- Principle of reinforcement of knowledge, abilities and skills is defined by necessity of their transforming into a part of students' mind, and a ground of their behavior habits. For teenagers the efficiency of skill acquisition directly depends on their comprehension of learning material and understanding of its personal significance. Implementation of this principle is revealed in students' ability to apply the newly

---

<sup>2</sup> 1 academic hour = 45 minutes

acquired knowledge on practice;

- Principle of individualization determines taking into consideration student's individual features (age, intellectual, psychological, physical and other specificities), and support of individual, specific and special development of every person's potential.

We define the main following course *thematic clusters* recommended for studying:

- «Health as supreme value». Objective: create students' notions of concepts of «health», «health saving»; develop a caring attitude to one's health and life; create a sense of responsibility, intention to care for one's own health and its protection.
- «ICTs in modern teenager's life». Objective: form an idea about different kinds and advantages of modern ICT in everyday life; produce an awareness what useful opportunities for a person offers a use of these appliances.
- «Influence of ICT on teenagers' health». Objective: form awareness about potential negative effects of ICT use on psychological and physical health of teenager.
- «Making a healthy environment». Objective: create students' ideas about abilities to create a safe working environment while using ICT.
- «Protecting eyesight and working capacity». Objective: create students' competencies in protection of healthy eyesight and preservation of long-term working capacities while working with ICT.
- «Making a correct posture». Objective: create students' skills about keeping correct posture while working with ICT.
- «Tantalizing virtual world». Objective: create students' knowledge of sense of dangers created by computer addiction and prevention of it.
- «On the other side of Internet communication». Objective: create students' knowledge of sense of dangers created by cyberbullying and prevention of it.

Within the scope of the course it's recommendable to use *interactive teaching methods*, which have proved their efficiency in work with BS students, in particular: interactive mini-lectures, group studying activity, group didactic games, demonstration and discussion of video fragments, discussions, justification of own ideas, brainstorming and others, which are designed to develop knowledge, abilities, skills and attitudes on health-saving use of ICT.

*Final control* of the course is represented by group project, the execution of which foresees an application of acquired knowledge and skills from different thematic sections of the course. Sense of the project, tasks of the project, stages of its execution, evaluation criteria are reported to students at the first (introduction) training class.

We define the following stages while preparing the group project:

4. Dividing students on mini-groups (3-4 people).
5. Choosing topic for each group.
6. Definition of objective, tasks, hypothesis, object and subject of the project, research methods.
7. Assortment and study of the material about the given issue.
8. Design of theoretical part of the project.

9. Design of questionnaire and conducting survey on research problem (among peers, younger grades students or others).
10. Analysis and design of the results of the survey.
11. Design of research project.
12. Creating visibility for presentation of the project.
13. Presentation of the project.

We offer to design the project according to the following structure:

1. Introduction (topicality of research problem, objective, tasks, hypothesis, object, subject, research methods).
2. Main part (theoretic overview of problem; analysis of results of peers' interviews concerning the research problem).
3. Conclusions, recommendations.
4. Appendices.
5. List of used sources.

By way of example, we offer the next topics for research project, which could be chosen by students at their own wish:

- Human health in epoch of informatization.
- ICT device: benefit or harm?
- ICT devices in modern teenager's life.
- Influence of ICT devices on health of junior student.
- Influence of electromagnetic radiation on human organism.
- Influence of ICT devices on human eyesight.
- Computer games and human health.
- Influence of global network on child's mind.
- Cyberbullying as social phenomenon of our time.
- Conditions of safe work with ICT devices.

The finished projects should be presented at the end of the course. After every presentation, it is advisable to discuss it and evaluate by teacher and other students. The finished projects could be represented at contests of students' works, school and local exhibitions, festivals of science etc.

*Diagnostic of levels of forming students' HSC* is reasonable to be done at the beginning of training course and upon its end in order to reveal the dynamics of this competence's forming.

*Evaluation of value and motivational component.* In most cases in order to define motivation for healthy lifestyle, surveys, interviews and discussions are applied. In general, the student's motivation could be defined by his/her verbal expressions, which allow indicating presence or absence of motivation, and its extent fairly accurate. In order to evaluate the level of forming of value and motivational components of HSC it is reasonable to use a method of survey.

*Evaluation of cognitive component.* In order to define a level of forming of HSC cognitive component it is reasonable to apply a pedagogical testing.

*Evaluation of operational and functional component.* Defining to what extent the students observe the requirements of health-saving use of ICT, is quite a complicated

task. We regard the following methods advisable: monitoring (during educational process at school) and conducting surveys (both of students and their parents are asked about the issue to what extent children observe health-saving rules at home).

The assessment methods for each component that we have developed are presented in our manual [8] in detail.

The level of forming of HSC of students' digital competence is calculated as arithmetical mean of all three components: value and motivational component, cognitive component and operational and functional component.

Having applied a diagnostic method, we can obtain two results:

1. Data on general formation level of student's HSC;
2. Data on formation level of each component of HSC, which allows in case of necessity to correct them.

*The result of study* at the author's training course should be a formed HSC of students' digital competence – their ability, knowledge, skills, attitude, and motivation to health-saving use of ICT during educational process.

In summary, forming HSC of students' digital competence allows creation of ground for safe use of ICT not only in educational institution, but also in extracurricular time, in private life and during leisure time. Implementation of purpose-oriented studying and educational events, coordinated interaction of all subject of educational process will facilitate preparation of young generation to conscious and responsible attitude to their own health, health-saving activity, also in aspect of use of ICT.

### **2.3 Empirical attesting of efficiency of author's method for forming the health-saving component of BS students' digital competence**

In order to validate efficiency of author's method a research was conducted about the definition of formation level of HSC of students from control group (CG) and experimental group (EG) at the beginning and at the end of experiment.

CG and EG were formed as follows:

- the CG included students of 7-9 grades of the 157th Lyceum of Kyiv, Ukraine (143 persons). Students of the CG used ICT in the usual mode;
- the EG included students of 7-9 grades of the 157th Lyceum of Kyiv, Ukraine (137 persons). For EG-students a cycle of training course on the topic "Health-saving use of ICTs" was conducted.

Thus, the students from CG studied in ordinary conditions, while students from EG studied according to the specially designed method and for them special training course was organized.

At the end of the study, experimental data have shown positive changes in levels of forming of HSC components of students who belonged to EG compared to levels of HSC components of students who were in CG.

**Control group.** Analysis of the results has shown that CG has *low (reproductive) level* of value and motivational component in 40 % of students at the beginning of experiment, and 33 % of them had it at the end of the experiment. Low level of cogni-

tive component and knowledge of safe use of ICT in educational process at the beginning of the experiment 63 % of students had and 54 % of them had such level at the end of experiment. Low level of operational and functional component, abilities and skills of safe use of ICT had 70 % of students at the beginning and 68 % of students at the end of experiment.

*Mediocre (constructive level)* of value and motivational component of HSC at the beginning of experiment was diagnosed in 43 % of students and in 47 % of students at the end of experiment. Mediocre knowledge of safe use of ICT in educational process 28 % of students had at the beginning, and 36 % of them at the end of experimental work. Mediocre level of abilities and skills in students about safe use of ICT during the learning process was found in 22 % of students at the beginning and in 23 % of them at the end of experiment.

*High (productive) level* of forming of value and motivational component, positive motivation and value orientation of students about health-saving use of ICT at the beginning of experiment was found in 17 % of students, in 20% of students at the end of experiment. High level of cognitive component, knowledge about safe use of ICT in learning process at the beginning of the experiment was found in 9 % of students and in 10 % of students at the end of experiment correspondingly. Advanced level of operational and functional component, abilities and skills in students about safe use of ICT were detected at the beginning of the experiment in 8 % of students and in 9 % of students at the end of experiment correspondingly.

**Experimental group.** There is a *low (reproductive)* level of value and motivational component in EG, which makes a ground for forming HSC in students: at the beginning of experiment, it was diagnosed in 41 % of students, and in 17 % of students at the end correspondingly. Low level of expertise about safe use of ICT in educational process was diagnosed in 60 % of students at the beginning of the experiment, and in 29 % of students at the end. Low level of abilities and skills of safe use of ICT in the process of studies was revealed in 67 % of students at the beginning of the experiment, and in 42 % of students at the end of experiment.

*Mediocre (constructive) level* of formation of value and motivational component of HSC at the beginning of experiment was displayed in 44 % of students, and 58 % showed it at the end of the experiment. Mediocre level of knowledge about safe use of ICT in studying process was revealed in 31 % of students at the beginning of the experiment, and in 46 % of students at the end. Mediocre level of abilities and skills of safe use of ICT in the process of studying was diagnosed in 23 % of students at the beginning of the experiment, and in 40 % of students at the end of experiment.

*High (productive) level* of value and motivational component of HSC, positive motivation and value orientations in students about health-saving use of ICT at the beginning of the experiment was revealed in 15 % of students, and in 25 % of them at the end of experiment. High level of cognitive component and knowledge about safe use of ICT in educational process was demonstrated by 9 % of students at the beginning of the experiment, and by 25 % of students at the end of experiment. High level of operational and functional component, abilities and skills of safe use of ICT in the process of studies was diagnosed in 10 % of students at the beginning of experiment, and in 18 % of students at the end of experiment.

Thus, as a result of the experiment we obtained a remarkable growth of indicators of high and average levels, and also reduction of indicators of low level of formation

of all HSC components in students from EG in comparison with students from CG.

In table 1 a comparative characteristics of levels of formation of HSC in students from EG and CG at the beginning and at the end of experiment are represented.

The analysis of the results provided in table 1 and figure 1 displays that in **control group** *high (productive) level* of forming of HSC (altogether in accordance to all its components) at the beginning of the experiment was found in 11 % of students, at the end of experiment it was found in 13 % of students; *mediocre (constructive) level* was found in 31 % of students at the beginning of the experiment and in 35 % of students at the end of the experiment; *low (reproductive) level* was diagnosed in 58 % of students at the beginning of the experiment and in 52 % of students at the end of the experiment.

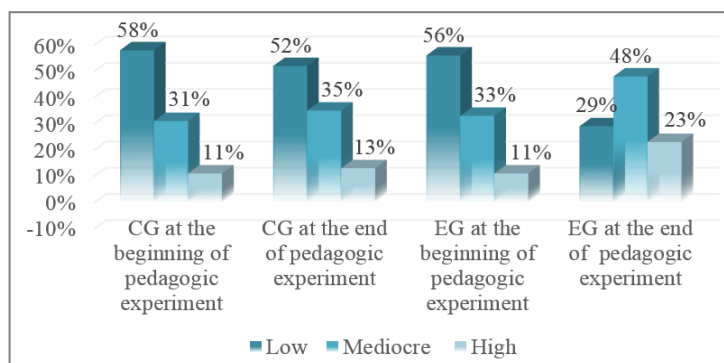
In **experimental group** *high (productive) level* of forming of HSC (together in accordance with all its components) at the beginning of the experiment was revealed in 11 % of students, and in 23 % of students at the end of experiment correspondingly; *mediocre (constructive) level* was found in 33 % of students at the beginning of the experiment and in 48 % of students at the end of the experiment; *low (reproductive) level* was found in 56 % of students at the beginning of experiment and in 29 % of students at the end of the experiment.

**Table 1.** Dynamics of levels of formation of HSC in students from EG and CG at the beginning and at the end of experiment

Item No.	Level	Number of pupils in CG, n=143					Number of pupils in EG, n=137				
		Pedagogic experiment									
		start		end		difference in %	start		end		difference in %
		in absolute terms	in % of general number	in absolute terms	in % of general number		in absolute terms	in % of general number	in absolute terms	in % of general number	
1	High (productive)	16	11	19	13	+2	15	11	31	23	+12
2	Mediocre (constructive)	44	31	50	35	+4	45	33	66	48	+15
3	Low (reproductive)	83	58	74	52	-6	77	56	40	29	-27

Having compared the results we have defined that indices in both groups have increased in all levels. In particular, high (productive) level of HSC has grown: by 2% in CG, by 12 % in EG; the number of students with mediocre (constructive) level of HSC has grown: by 4 % in CG, and by 15 % in EG. The number of students with low (reproductive) level of HSC has decreased instead: by 6 % in CG, and by 27 % in EG.





**Fig. 1.** Dynamics of levels of formation of HSC of students' digital competence in EG and CG at the beginning and at the end of the pedagogic experiment

The results obtained have testified that for the period of conducting forming stage in EG the number of students with low level of HSC has decreased significantly (from 56 % to 29 %), at the same time the number of students with mediocre (from 33 % to 48 %) and high (from 11 % to 23 %) levels of HSC has grown, what outruns significantly the results obtained in CG.

The validation of data differences for three criteria, obtained in EG and CG according to Pearson's chi-squared test  $\chi^2_{emn} = 20,79$  ( $20,79 > 5,99$ ), allows to make a conclusion about significance of these differences at the level of 95 % value and it generally attests efficiency of the offered method for forming HSC in students of BS.

Final analysis of the data obtained as a result of experiment has allowed to confirm a hypothesis that growth of level of HSC of BS students' digital competence is possible by means of author's method implementation.

### 3 Conclusions and discussion

On the current stage of development of the society one of the dominant problems is design of methods of students' health-saving in conditions of digitally oriented educational, safe use of ICT in learning process. The research of this problem bears an interdisciplinary character and requires application of knowledge from different scientific domains: pedagogic, psychology, ergonomics, informatics, medicine etc. Health-saving, ergonomically and pedagogically balanced use of ICT in educational process will facilitate the increase of efficiency and quality of didactic material retention, preservation of optimal working capacity level and functional state of students' organisms.

Forming of HSC of students' digital competence can produce a positive effect of reaching one of the principal objectives of studies with employment of modern devices – formation of healthy and competitive members of informational society, able to orient themselves in flows of information apply technologies at high and competent level.

It is defined that option of health-saving use of ICT is appropriate to be considered

within the scope of digital competence as one of its components – a health-saving component of digital competence. Forming of student's HSC envisages acquisition by him/her of the set of corresponding knowledge, abilities and skills, attitudes, persuasions, motivations, focused at preserving of physical and psychical well-being and health while use of ICT. For this purpose, the author's method was designed. The outcomes of the experiment have attested an efficiency of the developed method, thus it could be recommended for implementation in BS educational process.

We find prospective lines of further research in defining organizational and pedagogical conditions of health-saving use of ICT, determination of special features and ways of forming and development of HSC of digital competence in other subjects of educational process, teachers in particular.

## References

1. Balanskat, A.: The ICT Impact Report: A Review of Studies of ICT Impact on Schools in Europe, <http://www.comminit.com/?q=ict-4-development/node/72344>, last accessed 2019/03/24 (in English).
2. Ciccarelli, M., Portsmouth, L., Harris, C., Jacobs, K. Promoting healthy computer use among middle school students: a pilot school-based health promotion program, <http://content.iospress.com/download/work/wor0253?id=work%2Fwor0253>, last accessed 2019/03/24 (in English).
3. Dymova, A. L.: Information and communication technologies and their impact on the physical and psycho-physiological health of users. *Uchenye zapiski universiteta Lesgafta 10* (2008), <http://cyberleninka.ru/article/n/informatsionno-kommunikatsionnye-tehnologii-i-ih-vliyanie-na-fizicheskoe-i-psihofiziologicheskoe-zdorovie-polzovatelye>, last accessed 2019/03/24 (in Russian).
4. Hainsworth, A.: Legislating Computer Use Safety In The Classroom: Is It Possible? In: *Proceedings of the XVI International Conference on Occupational Ergonomics and Safety*, pp. 1–5. Toronto, Canada (2002), [http://www.iea.cc/ECEE/pdfs/LegislatingCompUse\\_Hainsworth.pdf](http://www.iea.cc/ECEE/pdfs/LegislatingCompUse_Hainsworth.pdf), last accessed 2019/03/24 (in English).
5. Hakala, P. T.: Musculoskeletal symptoms and computer use among Finnish adolescents – pain intensity and inconvenience to everyday life: a cross-sectional study, <http://bmcmusculoskeletaldisord.biomedcentral.com/articles/10.1186/1471-2474-13-41>, last accessed 2019/03/24 (in English).
6. Hun, H. E.: *Computer: how to keep healthy: recommendations for children and adults*. Izdatelskij dom «Neva», St. Petersburg (2003) (in Russian).
7. Muhametzyanov, I. Sh.: *Health-saving information and communication environment of an educational institution: problems and development prospects*. Idel-Press, Kazan (2010) (in Russian).
8. Nosenko, Yu. H., Sukhikh, A. S.: Health-saving component of students' ICT-competence as an important element of health-saving use of software and hardware tools in the educational process of basic school. *Nova pedahohichna dumka* 2 (86), pp. 30–35 (2016) (in Ukrainian).
9. Nosenko, Yu. H., Sukhikh, A. S.: *Health-saving use of software and hardware tools in learning process of basic school*. Komprint, Kyiv (2017) (in Ukrainian).

10. Polka, N. S., Platonova, A. H.: Updating hygienic requirements for the use of modern information technologies in educational institutions. *Komp'yuter u shkoli ta sim'yi* 4, pp. 3–5 (2015) (in Ukrainian).
11. Sukhikh, A. S.: Problem of health saving of secondary school students in terms of ICT use. *Informacijni tehnologiyi v osviti* 19, pp. 109–118 (2014) (in Ukrainian).
12. Vorontsova, E. V., Nosenko, Yu. H. , Sukhikh, A. S.: Determination of the level of awareness of basic school students and teachers regarding the health-saving use of software and hardware tools (research results). *Informacijni tehnologiyi i zasobi navchannya* 6 (44), pp. 93–106 (2014), <https://journal.iitta.gov.ua/index.php/itlt/article/view/1156>, last accessed 2019/03/24 (in Ukrainian).
13. Zlamanski, R., Ciccarelli, M. Do teachers believe they are competent to promote healthy ICT use among their students?, <http://www.ncbi.nlm.nih.gov/pubmed/22316831>, last accessed 2019/03/24 (in English).

# ICT in Professional Education of Future Primary School Teachers: Modeling of Scientific and Research Work

Yevheniia Spivakovska <sup>[0000-0002-7974-4736]</sup>, Tetyana Vinnyk, Liudmula Perminova and Vera Kotkova <sup>[0000-0002-1537-0923]</sup>

Kherson State University, 27, Universytets'ka St., 73000 Kherson, Ukraine  
spivakovska@ksu.ks.ua, tanya.vinnik@gmail.com,  
LPerminova@ksu.ks.ua, verakotkova84@gmail.com

**Abstract.** The usage of ICT has become an integral part of the learning process. It provides such benefits as improving learning efficiency, developing thinking culture, sharing knowledge and collaborating in the fast-paced digital society. The article is devoted to summarize the pedagogical conditions for future primary school teachers' research competences formation with the usage of ICT in education. The results of the survey of students' usage of different ICT are analyzed. The basic directions of modern students' scientific work are analyzed. The main directions of students' research work are discussed. On the basis of the analysis of students' usage of the ICT in scientific work, a five-step model of activity was created and tested, in particular, research planning, information phases, experiments, analytics, as well as the stage of project execution and presentation of research results.

**Keywords:** ICT, scientific work, research work, professional pedagogical education.

## 1 Introduction

Modern education of a teacher requires the students to do special research work and to become a professional with a set of research skills. It is also applied to primary school teachers due to the fact that the qualifications directly depend on the level of professional training as well as on the condition of the formation of research skills.

The problems of future teachers' scientific training have been reproduced in many Ukrainian and foreign studies. However, today there is no exact term of 'students' research activity'. It is a complicated synthesis of learning and student's new experience in the educational environment with a pedagogical direction. Research work means the process to form search skills and knowledge, scientific language the all these make a teacher ready to do his or her professional activities. It also contributes to the effective performance of professional functions, and is one of the criteria for qualifying a teacher, his readiness for self-development and innovations.

It should be noted that in today's conditions, the use of information and communication technologies has become an integral part of any sphere of human activity in

particular of education. Modern information tools provide students with a wide range of multimedia, electronic and Internet technologies as a result the ability to conduct, collaborate and share their research.

## **2 Ukrainian scientific works of students' researches.**

There is a new educational paradigm in Ukraine. Its ideas are intended to train specialists who unite both a competent worker and a researcher, who is capable to do his job in the conditions of continuous change of knowledge about the world. According to the overwhelming majority of scientists, the problem of professional competence of university graduates, and especially their preparation for scientific research, is actualized in the context of the transition to the information society.

It becomes axiomatic that the competence of a specialist researcher is one of the main conditions for his successful professional activity. Thus, O. Spivakovsky, L. Petukhova, N. Voropay and V. Kotkova emphasize the necessity of creating the informational-communication pedagogical environment, which ensures the positive learning motivation in today's informational and educational conditions [6].

The implementation of information technology in various fields of modern education system is becoming more and more complex and challenging [2].

A particular problem of the professional training of pedagogical workers is the optimization of informatization of higher education. The researchers singled out the main objectives of teachers' training within informatization of education [4]:

- to make the ideas about the role of computerization of higher education, types of information technologies and methods of their application;
- to introduce the positive and negative aspects of the usage of information technology in education;
- to study the experience of the using of information technologies in universities;
- to develop the personal information culture.

Thus, L. Petukhova notes that the traditional educational process does not ensure the formation of informational competence. It is the key competence for future specialists. The education is not effective unless it is aimed primarily to overcome the following difficulties:

- gaps in previously acquired knowledge;
- insufficient information culture;
- inability to choose the right mode of work and rest;
- lack of skills for independent study of the material;
- lack of skills for control their knowledge and skills;
- lack of systematic control of activity;
- insufficient self-esteem of their capabilities;
- insufficient number of consultations allocated to each of the disciplines of the pedagogical cycle;
- insufficient level of development of research skills;

- low level of development of abstract and analytical thinking and creative abilities of students, etc. [8].

At the same time, the analysis of special literature shows a fairly large number of works that raise the issue of ICT usage in student's learning activities, in particular research. The availability of an adequate informational and pedagogical environment facilitates the assimilation of a large amount of information, which is important in the context of intensive development of scientific and technological and social progress, where knowledge is updated every 3-4 years with a clearly defined rate of reduction of this process.

At the same time, the analysis of literature shows a large number of works that raise the question of using ICT in the students' learning activity, particularly in research. The availability of an adequate informational and pedagogical environment facilitates the assimilation of a large amount of information, which is important in the context of intensive development of scientific and technological and social progress, where knowledge is updated every 3-4 years with a clearly defined rate of reduction of this process. The availability of an adequate informational and pedagogical environment facilitates the assimilation of a large amount of information, which is important in the context of intensive development of scientific and technological and social progress, where knowledge is updated every 3-4 years with a clearly defined rate of reduction of this process.

On the basis of the analyzed literature it can be argued that the timely and correct use of innovative educational resources in the educational process and research work, the constant interaction of the student and the teacher in the information and communication pedagogical environment will lead to the improvement of the quality of educational services, and to the increasing of students' preparedness level to study higher education, improve the quality of educational services provided by higher educational institution. Consequently, in the context of the dynamics of modern society, the future teacher should be prepared to acquire and comprehend new information, its improvement and application in the educational process by means of innovative technologies.

### **3 The investigation of ICT usage in students' researches**

The teacher's professional training is carried out not only in the process of learning the theoretical course, but also in the course of educational work by tools of pedagogical practices, students' participation in research activities.

Of course, each kind of work has a research nature, and all types of educational activities of the higher education institution influence on the formation of research skills of future teachers. High level of professional training requires a clear organization of educational work, which provides a search and problem approaches to its implementation. First of all, it refers to the methodological substantiation of the educational process, that is the system of initial positions and methods of organizing theoretical and practical educational activities in modern conditions.

Conducting research on this issue determines the use of both theoretical and empirical research methods. Thus, studying the readiness of students to use information

technology in scientific work is impossible without analysis, comparison and synthesis, an abstract approach to determining the basic laws of the use of information technology, a logical approach to describing their possible implementation of innovative educational methods. The main means of obtaining results are conducting questionnaires and analysis of indicators of readiness of students of pedagogical specialties of higher educational institutions of Ukraine to use information technologies in the educational process and research work. As known, the Ukraine's Higher Education Institutions use information technologies in the educational process and research work.

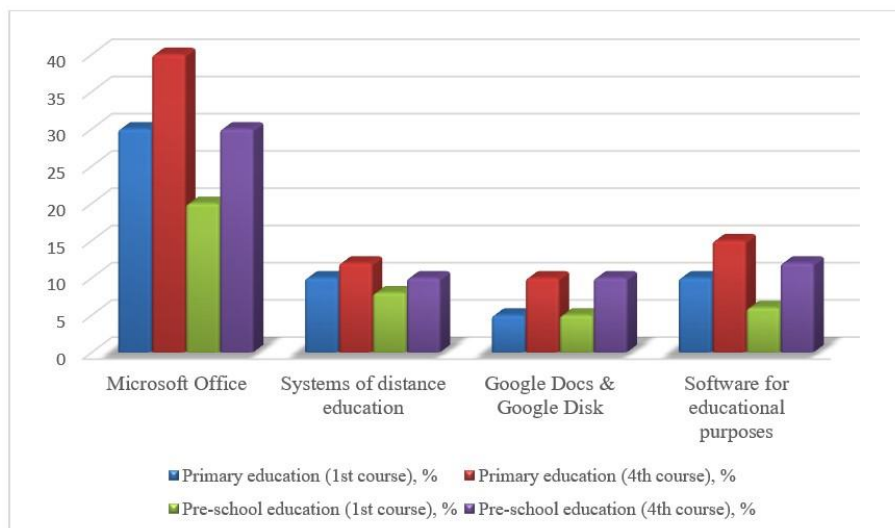
This research was conducted on the basis of the pedagogical faculty of the Kherson State University within the framework of research work. It included a series of surveys aimed at researching various aspects of ICT use by students. It should be noted that the material base of the faculty is at the necessary and sufficient level. Students have access to the computer classes; each classroom is technically staffed.

The questionnaire received answers of 100 respondents who are students of the 4th year of the Pedagogical Faculty of Kherson State University, specialty "Elementary education", "Preschool education". In order to determine the basic level of use of ICT by students, we have identified quantitative and qualitative indicators, which made it possible to predict future psychological and pedagogical measures for forming the readiness of the use of technical means.

It is important to monitor the dynamics of the use of modern information technologies and their impact on the quality of educational services, because this is the way we get an opportunity to analyze the state of the functioning of the education system as a whole and determine the prospects for its development, which are taken into account in the process of formation of the state policy in the field of education.

The results were compared with the results of the research of 2015/2016 years, which was conducted among the students of pedagogical specialties [5]

Based on the results, you can see a dynamic picture of the use of ICT by students of the Pedagogical Faculty of the Kherson State University. The difference between the level of use of ICT at the beginning of study at the end is shown in Fig. 1.

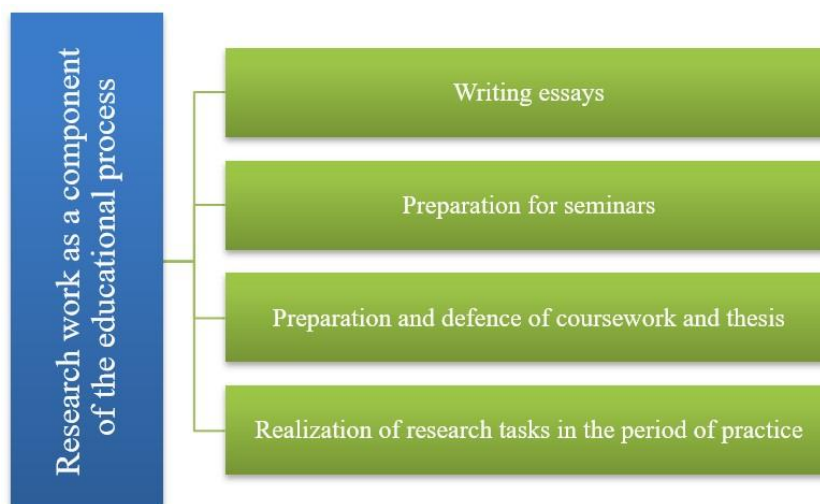


**Fig. 1.** Use of different types of ICT by students of the Pedagogical Faculty

Based on the results, we can state that the level of intensity and quality of ICT application by students of pedagogical specialties increased during the period of study at the university.

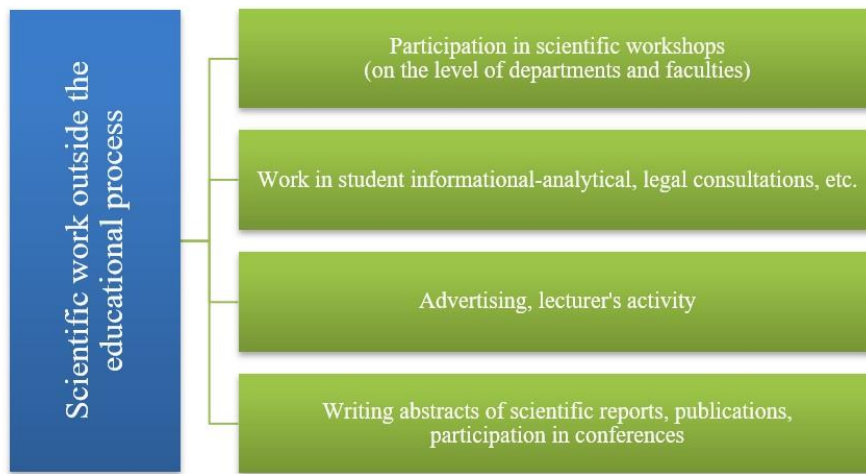
At the same time, since the third year of education, students are became actively involved in various types of research, which requires them to apply innovative communication technologies and appropriate actions.

Let's consider the main directions of students' research work(Fig. 2, Fig. 3).



**Fig. 2.** Main directions of students' research work in educational process





**Fig. 3.** Main directions of students' research work outside the educational process

As is known, the most traditional means of formation of research competences include lectures, seminars, practical and laboratory work. The specific load of a lecture in the course of scientific work of a teacher is to attract students to creativity, to increase their interest in research. This is realized by providing a problematic nature of teaching the material, an optimal combination of traditional and innovative teaching methods. As a result of the survey of students of the Pedagogical Faculty of Kherson State University, lectures, discussions, lectures, press conferences, lectures-visualizations, lecture-round tables, problem lectures, etc. proved to be effective.

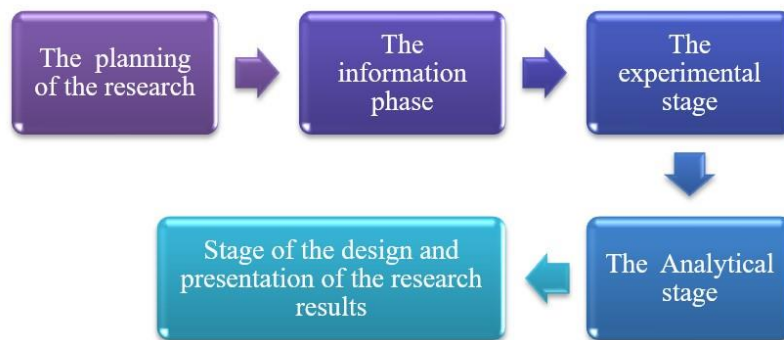
The results of our research confirm that in the system of scientific and cognitive training of students a significant place should belong to the creative nature of the organization of seminars and practical classes, the main purpose of which is the formation of skills of practical application of theoretical knowledge, the ability to use them in future professional activities. By means of specially developed creative tasks the ability to laconic and logically express own opinion develops, the skills of the search and processing of information are formed. Inclusion of elements of experimental search, creation of situations for intensive development forms an interest in scientific work and skills of the collective activity of the future teacher.

The most effective organizational forms include seminars-discussions, colonial seminars, workshops, consultations, independent work, as well as game techniques, competitions, round tables, debates, etc. A prerequisite for improving the level of student research is the use of active methods, which include role games, psychological sketches, modeling, etc. Special mention should be made of the development of mini projects during the classes themselves and individual and group projects that are being developed outside of the auditorium. Their potential opportunities ensure the search character of learning, the intensive development of scientific knowledge of students, prepare for creative professional activities, independent acquisition of the necessary information base [8].

Unfortunately, a significant number of students do not possess the skills of the search and processing of scientific information, does not have a clear idea about the structure of scientific works, the problem is the adequate selection of research methods. Thus, there is a need to create favorable conditions for the implementation of the readiness for the use of innovative communication technologies, based on beliefs and clear value orientations, in which the motivational component is considered as the person's quality, on which the person's attitude to his behavior and activity depends.

It should be noted that there is need for wider involvement of future teachers in "optional" forms of research, such as participation in scientific laboratories, unions, exhibitions, competitions, contests, scientific seminars [1, 5, 7].

The introduction of ICT into the research work of students is possible at each stage of the research. Thus, for example, student research during the writing of scientific papers in general form can be submitted in the form of an active model consisting of five stages:



**Fig. 4.** Stages of students' scientific work

Let's describe the possibilities of using ICTs at each stage (Fig.4).

1. The planning of research (selection, study and synthesis of scientific and statistical information, consideration of possible directions of research and their evaluation, choice of study direction, justification of the accepted direction of research):
  - Information systems and resources (search engines, electronic catalogs and repositories)
  - MindMeister, Mindomo, MAPMYself, Spinscape, Text2MindMap, VivaMind, and other software for creating mental maps.
2. Information phase (search and selection of information, accumulation of various facts concerning the subject of research received by other scientists)::
  - search engines (Google, Rambler, Bing, Yahoo! etc.)

- electronic catalogs and repositories (Electronic Catalog of the Vernadsky National Library, ELibUkr, Scientific Electronic Library of the Periodicals of the National Academy of Sciences of Ukraine, DissForAll, DissCat, etc.)
  - Internet bookmarking services (Google's built-in service, Pocket, Streme, Saved.io, Memori, Xmarks, etc.).
  - online data warehouses (Google Docs, DropBox, Mega etc.).
3. Experimental stage (staging and conducting an experiment for obtaining own facts, new knowledge about the subject of research)
  4. Analytical stage (analysis of all acquired facts about the subject of research, their generalization, interpretation, allocation of correlation and causal relationships, justification of regularities, etc.):
    - special computer programs for the receipt and processing of analytics and its presentation in graphical form
    - Feedback services
    - digital devices
    - Information systems and resources (search engines, electronic catalogs and repositories)
    - online storage (Google Docs, DropBox, Mega, etc.)
  5. Design and presentation of research results:
    - Text editors for presentations and videos (MS PowerPoint, ProShow Producer, OpenOffice.org Impress, Corel Show, etc.).
    - Internet resources for placing research results (YouTube, Web pages of the research group, etc.).

To summarize, it can be argued that there is a real opportunity for a modern high school to participate in research work with the help of using certain types of legal training for future primary school teachers. But the students' lack of experience is the reason of learning without enthusiasm, without getting any satisfaction from the exercises. Often it can be caused by the lack of motive for scientific research, the absence of professional orientations, the instability of the desire for knowledge.

In our opinion, the lack of interest in independent creative activity of students is caused by:

- their low informativeness about types of scientific activity in higher education;
- organization of the educational process on the laws of simple reproduction of knowledge and skills;
- optional participation in extra-curricular research work;
- lack of a system of encouragement for scientific research;
- insufficient level of scientific and pedagogical preparation of a part of teachers (absence of the necessary “scientific school”)

The negative aspect in students' scientific training is a formal approach to the choice of the subjects of course and thesis, the reluctance and the inability to conduct

an experimental phase of the study. the consequence is the unsystematic nature of special knowledge, insecurity in their forces, passivity, weak motivation for scientific research [3, 4].

We were interested in T. Vakolya's study, conducted on the basis of the pedagogical faculty on the problems of forming the research competence of future teachers of elementary school. The author has proved that the formation of research competence should take place in stages: diagnostic-prognostic, informational, practical, creative-heuristic.

Diagnostic-prognostic (1 course) -occupied with collecting the necessary information about the first-year students, studying the motivational palette, diagnosing the levels of formation of scientific research knowledge and skills of students. The second - informational (2 year) - carried out intensive accumulation of experience in acquiring scientific information, system of research knowledge, preparation for independent research, acquaintance with research methods and forms of scientific work in higher educational institutions, development of reflection. The third - practical (3 course) - provided the experience of methodology of pedagogical search, methods of transformation of pedagogical activity, which are transformed into creative projects, systematization of experience of practice, registration of scientific products, introduction of the results of independent scientific research, formation of personal qualities. The fourth - creative-heuristic (4 year) - envisaged the student's awareness of the objective way of professional activity, the ability to reflect, readiness for self-improvement on the basis of self-analysis and the synthesis of individual properties and acquired pedagogical experience, readiness to simulate future professional search activity. At this stage, the systematization of the acquired research knowledge and skills [4] was completed.

This approach allows students to purposefully accumulate the necessary research skills. Naturally, the involvement of students in research activities is preceded by their familiarization with methods and methods of scientific research, the ability to collect material, work on literature, the use of scientific apparatus.

The main thing in teaching is not learning a huge array of information, but the ability to independently acquire it, purposefully work with it, choose the necessary knowledge, have a mechanism for systematically replenishing and updating your own thesaurus.

At the same time, the productivity of research activities at the specified stages depends on the quality of use of information and communication technology, which is a means of positive self-realization of the student in education.

As a result of the diagnosis, the following results were obtained (Table 1, 2).

**Table 1.** Characteristics of students' readiness for carrying out of pedagogical researches on a control slice (in percent)

Criteria	Levels								
	High			Medium			Low		
	K	E	D	K	E	D	K	E	D
Research knowledge and skills	3,7	15,2	11,5	25,3	60,4	35,1	71,0	24,4	46,6
Motivational orientation	9,8	20,9	11,1	30,6	53,2	26,2	59,6	25,9	33,7
Research qualities, productivity of activity	7,6	18,3	10,7	32,4	50,0	17,6	60,0	31,7	28,3
Communicative	4,7	16,8	12,4	21,7	51,3	29,6	73,6	68,1	5,5
Reflexivity	7,2	21,8	14,6	28,4	49,7	21,3	64,4	28,5	35,9
On the average	7,1	19,0	11,9	29,2	53,3	24,1	63,7	27,6	36,1

Where:

K - control group;

E is an experimental group;

P - difference in indicators.

**Table 2.** Characteristics of students' readiness for conducting pedagogical researches on the results of the forming stage of the experiment (in percentages)

Criteria	Levels								
	High			Medium			Low		
	K	E	D	K	E	D	K	E	D
Research knowledge and skills	12,8	25,1	12,3	30,2	55,1	24,9	57,0	19,8	47,2
Motivational orientation	16,0	34,0	18,0	35,8	55,2	19,4	48,2	10,8	37,4

Criteria	Levels								
	High			Medium			Low		
	K	E	D	K	E	D	K	E	D
Research qualities, productivity of activity	15,8	36,2	20,4	40,5	55,4	14,9	43,7	8,4	35,3
Communicative	11,2	31,6	20,4	32,1	54,2	22,1	43,3	14,2	29,1
Reflexivity	11,6	40,1	28,5	40,3	55,0	14,7	48,1	9,6	38,5
On the average	14,0	33,8	19,8	36,7	57,6	21,0	49,3	8,6	40,7

Consequently, the results indicate a significant increase in the indicators of the formation of preparedness for conducting pedagogical studies of future teachers of elementary school.

Looking forward to solving the problem of developing the research competence of future primary school teachers, in our opinion, the following directions can be considered: the further search of effective technologies and means of forming research competence; creation of more modern models of integration of research competence with other components of professional culture of students; studying and using the latest information tools; further study of ways to improve the quality of management of the process of forming the research competence and competence of the leaders of the scientific work of students, which in essence should be facilitators, in the form of tutors (changes of the outdated system of curatorial activity).

The research allowed to identify a number of contradictions in the pedagogical, methodological and scientific nature of the informatization of higher education. In particular, the contradiction between the orientation of pedagogical practice to the intensive process of informatization of higher education (the introduction of information and communication technologies in the educational process) and the lack of established generally accepted methodological and theoretical foundations of the process of informatization, its strategic prospects for development. Another contradiction is the presence of updated and improved technical means of training and the development of a methodology for their implementation in higher education.

#### 4 Conclusions

Informatization of education is one of the main priorities in the development of higher education. It is a qualitatively new stage for the whole system of higher education, a promising direction for increasing the efficiency of the studying at a higher educational institution.

The analysis of students' usage of ICT resources in the learning and research makes it possible to assess its level as low. Thus, this indicates the need to increase the level of IT ownership, from high school and during studies in universities. The research revealed an imbalance between the opportunities of the university's information and communication pedagogical environment and the readiness of students to use IT resources from the beginning of education. One of the ways to increase the readiness of students to use information technology in the educational process and research work is to use computer communication tools, social networks, software such as Microsoft Office, Google Docs, etc.

The generalization of the necessary information and the results of our research shows that the problem of forming the research competencies of future primary school teachers is due to the influence of a number of reasons: the lack of substantiated recommendations for the development of scientific potential in the realities of social requirements, the educational process is not focused on the formation of research competencies as a component of professional training, not the possession of a part of teachers of higher education by the relevant conceptual and terminological apparatus, unmotivated students to vocational and scientific research, etc. The synthesis of training and obtaining the experience of conducting scientific research is the attraction to the search activity, the theoretical foundations of which are laid both in the process of mastering academic disciplines, and in practical implementation through the preparation and protection of abstracts, coursework and diploma papers, participation in problem research groups, student laboratories. The direct influence on the course of the algorithm of the educational process is the motivation of choosing a future profession, the availability of adequate introspection, the ability to predict the mechanism of professional growth and self-improvement. In the future, further exploration is the development of a model for the formation of the research competence of the future teacher of elementary school on the basis of the competency-axiological approach.

## References

1. Andrievsky, B.M., Vinnyk T.O.: ICT as an Independent Component of Preparing Future Teachers of Primary School to Scientific and Professional Research. *Information Technologies in Education*, 23 (2015)
2. Andriyevsky, B.M., Petukhova, L.E.: Professional and scientific training of the future teacher of elementary school. Kherson, Aylant (2006)
3. Baseluk, V.G.: Formation of research skills of the head of general educational institutions in the system of postgraduate pedagogical education. Kyiv (2009)
4. Vakolya, T.I.: Formation of research competence of future primary school teachers in the process of training. Kherson (2014)
5. Spivakovska, E., Osipova, N., Vinnik, M., Tarasich, Y. Information competence of university students in Ukraine: Development status and prospects. 2014, *Communications in Computer and Information Science*, 469, pp. 194-216.
6. Spivakovskiy, A., Petukhova, L., Spivakovska, E., Kotkova, V., Kravtsov, H. Comparative analysis of learning in three-subjective didactic model. 2013. *CEUR Workshop Proceedings 1000*, pp. 236-251

7. Vinnik, M., Tarasich, Y.: Students Readiness to Use Information Technology in Universities Educational Process. *Informational Technologies in Education*, 23 (2015)
8. Perminova, L.A.: Didactic Preparation of Future Primary School Teachers by using ICT. Kherson (2017)



# Design of Approaches to the Development of Teacher's Digital Competencies in the Process of Their Lifelong Learning

Nadiia Balyk<sup>[0000-0002-3121-7005]</sup>, Yaroslav Vasylenko<sup>[0000-0002-2954-9692]</sup>,  
Galina Shmyger<sup>[0000-0003-1578-0700]</sup>, Vasyl Oleksiuk<sup>[0000-0003-2206-8447]</sup>,  
and Anna Skaskiv<sup>[0000-0002-3548-2383]</sup>

Ternopil Volodymyr Hnatiuk National Pedagogical University  
2 M. Kryvonosa St., Ternopil, Ukraine  
{nadbalyk, yava, shmyger, oleksyuk, skaskiv}@fizmat.tnpu.edu.ua

**Abstract.** At present, various strategies and initiatives focused on innovation of educational technologies in higher pedagogical education are offered in Ukraine. The study of the state of the formation of teachers' digital competencies in the process of their professional development has been carried out on the basis of Ternopil Volodymyr Hnatiuk National Pedagogical University.

The article analyzes foreign and national approaches and strategies to the development of teachers' digital competencies. The results of the study, aimed to determine the features of mastering digital competencies in the process of teachers' professional development and their lifelong learning, are presented. In total, 258 teachers from Ternopil and Ternopil region (Ukraine) took part in this research. The study combines a variety of statistical tools and techniques in the real contexts of higher education. The research has been carried out to determine the characteristics of elements that measure the digital competency of the professional development. The results were processed based on the *Item Response Theory* (IRT). This article demonstrates the utility of the standardized LD  $\chi^2$  statistic and the  $M_2$  statistic as provided in the software IRTPRO, but not available readily in most IRT programs and not discussed commonly in pedagogical papers for IRT.

On the basis of the research carried out at the Ternopil Volodymyr Hnatiuk National Pedagogical University, the strategy for the professional development of digital competencies of teachers in the process of their lifelong learning has been developed, which takes into account the results of the analysis of the criteria and indicators inherent for the qualitative improvement of qualifications, that have been determined by international standards and studies of professional institutions.

**Keywords:** digital competencies, approaches, professional development, teacher training, lifelong learning.

## 1 Introduction

Society's digitalization involves the need to create strategies for the development of a modern educational digital environment. As digital technologies are becoming central part of everyday work, teachers are made to rethink and transform educational traditions through new technologies and learn throughout their lives. This problem requires the creation of approaches to the development of teachers' digital competences in the process of their lifelong learning.

The reform of Ukrainian education involves a new educational strategy that focuses on the pupils and on the competence learning. This approach involves fundamental changes in the professional priorities and school teachers' roles [23]. Teachers must adapt their professional competences in accordance with the requirements of the modern digital technologies development. Therefore, professional qualification improvement and lifelong learning are of paramount importance for the development of teachers' digital competencies.

## 2 Justification of the problem

Digital education is a multifunctional concept that includes the structure, culture and goals of schools, new roles of teachers and pupils. Increasing the efficiency of digital pedagogical education requires special attention to the acquisition of digital competences in the process of professional development of teachers and their lifelong learning [6; 22; 3; 2].

Digital competence regards the ability to use digital technology effectively and to function properly in a digital society, which is an essential part of lifelong learning [20]. Acquiring digital competence refers to the learning to adapt the culture with strong technological, informational and communicative elements.

The problem of distinguishing the main competences in digital education and teacher professional training is relevant and important today. The research [18] focuses is on the approaches to the development of digital competences in educational contexts. The author analyzes international studies over the past 10 years from the point of view of politics, organizational infrastructure, strategic leadership, as well as of lectures and their practices.

Hall R., Atkins, L. and Fraser, J. [10] reviewed a variety of four-level digital competency structures that determine critical digital interest in achievement progress from the basic requirements to the demonstration of expert, transformational skills, practice and knowledge.

The levels of digital competence, specified in the DigEuLit project [14], changed from the digital competency, general skills and approaches to the digital use and professional application of these skills.

Competency approach is becoming a standard of pedagogical innovations [5] and a major factor in the reformation of education system [11; 12].

In recent years, pedagogical aspects of the digital competence have been discussed [7; 27; 13]. From J. [7] confirms that the pedagogical aspects of digital competence

should be considered not only at the level of teachers' competence, but also at the administrative level of school organization.

Ottestad, G., Kelentrić, M., Guðmundsdóttir, G. [15] described the use of ICT for pedagogical and didactic purposes in Norwegian pedagogical curriculums. In the context of their research, pedagogical education is of paramount importance for the development of digitally competent teachers. They offer three main dimensions to describe the professional competence of teachers: the Generic digital competence, the Didactic digital competence and the Professionally-oriented digital competence.

The strategy of integrating digital competences into the professional teachers' development has been analyzed in the study [19]. The model includes a frame of 7 digital competences, 78 units of digital competences divided into three levels of competence development: the Basic Knowledge, the Knowledge Deepening and the Knowledge Generation.

Tømte C., Kårstein, A., Olsen, D. [24] have revealed that the development of professional digital competences in the whole world is poorly developed at the level of pedagogical curriculum management and there is no complex approach to the development of such competencies in most of the curriculum programs. In addition, they noted that the academic strategies of pedagogical educational institutions on this topic are not efficient enough and that the teaching staff' experience varies greatly. Encouraging the professional digital competency of students and teachers in many pedagogical curriculum programs depends on enthusiasts among teachers.

In their studies, Gudmundsdottir, G., Loftsgarden, M., Ottestad, G. [8] stated that only a few graduates – qualified teachers were satisfied with their knowledge and skills gained at the university for work in a class equipped with digital instruments. At the same time, teacher practitioners were interested in further development and deepening of their digital competence, even if the schools in which they work do not set clear requirements about the use of digital technologies for teaching and learning.

There are relatively few examples when a pedagogical institution clearly describes how digital competence may be related to what a good teacher should be, or what digital competencies will be formed in the process of teacher training and their lifelong learning. Authors [24; 25] also note that there is the need to improve collaboration between schools and pedagogical universities in order to develop approaches to supporting teachers' digital competences.

Digital competences continue to be a problem for pedagogical practice and educational innovation, as well as the integration of digital technologies into the learning process. Our main attention in this research is focused on the need to develop approaches to developing the digital competence of teachers in their professional qualification improvement and lifelong learning.

### **3 The Presentation of Main Results**

#### **3.1 Methodology for identifying the teachers' needs in digital competences acquisition in the context of their professional development**

During the research, we have used a set of research methods, namely: theoretical – analysis of scientific and educational-methodical literature, official documents of the European Union and the Ministry of Education and Science of Ukraine in order to determine the theoretical fundamentals of the problem acquisition; empirical – observation to identify the teachers' needs in the digital competences in the process of their professional development and lifelong learning; development of the approaches to the development of teachers' digital competences in the process of their lifelong learning; statistical methods of mathematical processing of scientific data for the research results analysis and interpretation.

The conducted research is comprised of the following stages:

1. Review of the documents to reflect the contemporary understanding of the teachers' digital competences needed in the digital society and the education system.
2. Analysis of the digital technologies impact on teachers' professional development, role and functions in order to identify their needs for digital competency training in the context of professional development.
3. Creating the questionnaire for assessing the teachers' needs in digital competence training and advanced training in this field. The research strategy from the beginning involved the use of online survey.
4. Statistical processing of results and summing up.
5. Development of the approaches in order to the develop teachers' digital competences in the process of their lifelong learning.

At the end of 2017, the preparatory phase of the study, consisting of series of interviews with experts on the digital competences integration into teachers' professional development and lifelong learning, took place. The preparatory phase laid the foundation for a clearer statement of goals and objectives, clarification of the methodology, contributed to the formulation of research hypotheses and to the development of research tools.

The data collection phase has been conducted through the online survey. To collect data for the study, the questionnaire with four sections was used and it contained 14 questions reflecting the objectives of this study. The survey lasted from February 20 to May 5, 2018. The time of work with the questionnaire was expected approximately on 20 minutes.

258 respondents were involved through various informational channels on anonymous and free-of-charge basis. The target audience of the experiment was represented by rural teachers ( $n = 127$ ) working at schools of Ternopil region and teachers of the city of Ternopil ( $n = 131$ ).

The results of the experiment have showed that 75% of teachers are women, and the rest are men. Most respondents were between the age of 28 and 58. Regarding the professional profile of the respondents, the experiment has revealed that 70% of the

respondents had ten or more years of pedagogical experience, 30% – less than 10 years.

The study revealed that there is a link between some of the demographic characteristics of respondents (age and place of residence) and their need for digital competence in the context of their professional development.

The research has also ascertained that there is a significant link between all respondents' professional characteristics in particular with the subject they teach at school, their position, their work experience and their need for the digital competence in the context of their professional development.

In the process of research such theses have been confirmed:

Both rural and urban teachers are generally not satisfied with the existing system of teacher' qualifications in the field of digital competence development.

During the advance teachers' improvement in order to develop digital competences, traditional trajectories dominate that are often characterized by the limited creativity and by the lack of innovation practices.

Study has showed that among the challenges affecting teachers' digital competence of acquisition in professional development and their lifelong learning, there were the lack of funds (46%), lack of time (51%), lack of motivation for professional growth (42%), as well as the problems, associated with the educational sector in Ukraine (21%), that were significant to them.

The author's strategy of the designing of the approaches in order to develop digital competences in the process of professional training and teachers' advanced training is based on the European Digital Comprehensive Teachers Framework – DigCompEdu [2; 21]. The digital competency of professional development contains 14 criteria, which are grouped into 4 groups. The selection of criteria has derived from our experience of teachers' training organization in the training center "Educational Innovation" studies in the context of their digital competencies development.

At the preparatory stage, we suggested teachers to evaluate their level of digital competencies development. The assessment has been carried out in a 5-point scale based on the proposed criteria (see Table 1).

**Table 1.** Criteria for assessing the digital competency of professional development

<b>1. Organizational communications.</b>	<b>The use of digital technologies for:</b> OC1. Access to pupils and parents' resources and information
The use of digital technologies for communication between institutions and a teacher with stakeholders.	OC2. Communication with colleagues by means of digital technologies OC3. Access to the joint development of communication strategies of the institution
<b>2. Professional cooperation.</b>	<b>The use of digital technologies for:</b>
Using digital technologies to collaborate with other education workers, sharing knowledge and experience.	PC1. Collaborative with other educators to implement educational projects PC2. Sharing resources and experiences with colleagues

	PC3. Collaborative development of educational resources
	PC4. New pedagogical practices and methods study
<b>3. Reflexive pedagogical practice.</b>	<b>The use of digital technologies for:</b>
The use of digital technologies for individual and collective reflection, the active development of their own digital pedagogical practice.	RPP1. Finding of gaps in digital competency
	RPP2. Search for educational materials for advanced professional development
	RPP3. Appealing for help to others to improve their digital pedagogical competence.
<b>4. Professional lifelong development</b>	<b>The use of digital technologies for:</b>
The use of digital technologies and resources for advanced professional development.	LLD1. Planning your own learning
	LLD2. Updating their professional subject competences
	LLD3. Providing opportunities for colleagues training
	LLD4. Use of online learning opportunities

We have provided five possible options (categories) of answers for each item of questionnaire: 1 – very low level (initial level), 2 – low level, 3 – medium level, 4 – sufficient level, 5 – high level (expert level). For further statistical analysis of the obtained data, we used the modern theory of testing IRT. This theory compared with the classical theory of testing has such advantages as objective estimates of task parameters and knowledge level parameters.

For statistical processing of the data obtained, we used the IRTPRO software. The response categories of 1, 2, 3, 4, 5 were translated into item scores 0, 1, 2, 3, 4 (interior codes of response categories) by this program.

As far as obtained estimates depend on the level of teachers' digital competence ( $\theta$ ) and on the complexity of the questionnaire questions ( $\delta$ ), we used the assumption of the unidimensionality of our model. That is, the probability that the participant of the test with the level of preparedness ( $\theta$ ) executes the task of difficulty ( $\delta$ ) is calculated by the formula

$$P(\theta - \delta) = \frac{1}{1 + e^{\theta - \delta}} \quad (1)$$

The probability of success depends, in essence, only on one parameter - the difference  $\theta - \delta$ . The level of preparedness  $\theta$  and the complexity of the task  $\delta$  are measured in logits and are plotted on the same scale.

### 3.2 Statistical and mathematical analysis of research data

First, we have checked the questionnaire (test) for internal consistency. To do this, for all 14 questions, the coefficient alpha Cronbach have been calculated. It was acceptable ( $\alpha=0.8604$ ).

Local independency. One of the assumption of unidimensional IRT models is that of local independency (LI) or conditional independence. LI is the assumption that is the only that influences on an individual's item response is that of the latent trait variable that is measured and that no other factors (e.g., other items on the measuring scale or another latent trait variable) is influencing individual item responses. Local dependency can occur for numerous reasons such as when the wording of two or more items consist of the synonyms used across items that teachers can't differentiate between items, but only by selecting the same response category across items.

To assess the tenability of local independency, the standardized LD  $\chi^2$  statistic for each item pair has been examined. LD statistics greater than |10| are considered large and reflecting likely LD issues or residual variance that is not accounted for by the unidimensional IRT model. LD statistics between |5| and |10| are considered moderate and questionable LD, and LD statistics less than |5| are considered small and inconsequential.

LD statistics for 14-item five-category scale are summarized in Table 2.

**Table 2.** Standardized LD  $\chi^2$  Statistics

Item	Label	1	2	3	4	5	6	7	8	9	10	11	12	13
1	OC1													
2	OC2	2.0												
3	OC3	0.1	0.8											
4	PC1	0.1	-0.7	0.9										
5	PC2	4.0	-1.0	0.2	0.8									
6	PC3	5.3	-0.8	2.5	0.2	3.5								
7	PC4	-0.6	0.6	0.2	1.4	0.1	3.2							
8	RPP1	4.0	0.6	4.5	0.3	1.1	1.0	1.8						
9	RPP2	2.1	-0.1	0.7	0.7	0.4	3.9	3.0	1.8					
10	RPP3	1.7	3.0	2.7	1.2	0.4	0.4	3.3	2.1	-0.4				
11	LLD1	3.2	1.1	1.8	-0.5	7.2	1.5	2.0	1.6	1.5	0.2			
12	LLD2	-0.3	-0.7	-0.9	2.5	0.7	0.3	-0.1	1.1	1.7	0.2	0.1		
13	LLD3	-0.5	3.3	-0.6	1.3	-0.2	2.3	1.1	0.6	0.5	4.3	0.4	-0.1	
14	LLD4	0.6	0.3	1.0	0.2	2.9	-1.6	0.2	2.1	0.4	-0.3	1.6	0.8	2.8

Overall, LD statistics for the model corresponds to the 14-item five-category scale and shows that most LD statistics are relatively small. Based on these results, the assumption of local independency is tenable.

Unidimensional IRT models have the assumption, known as functional form, which states that the observed or empirical data follow the function specified by the IRT model. In the context of the IRT model, functional form implies that all threshold parameters are ordered and that there is a common slope within each item, although not necessarily across items. Essentially, the comparison has been made between the empirical data and those that were predicted by the IRT model.

In addition to assessing model-data correspondence, it is important to check if each item refers to the category system and operates as expected. To assess whether categories usage corresponds as expected (or not) to the IRT model (14-item five-

category scale), ORF (option response function) plots of each item have been inspected.

Software has been used to generate the ORF plots for all items, IRTPRO has an easily accessible feature of this once. Figure 1 [15] provides ORF plots for all items, which is typical for the IRT model.

As it can be seen, the predicted ORF plots shows that all items deport themselves as a five-category item, with a category score of 0 (very low level) and is less likely to be selected than any other category for almost the entire competencies continuum (i.e., between -3 and 3).

Assessing IRT Model-Data Fit. To assess the correspondence of the model to each item, a  $S-\chi^2$  item-fit statistic for polytomous data has been examined. This item-fit statistic is provided by default in IRTPRO. For each item,  $S-\chi^2$  assesses the degree of similarity between the model-predicted and the empirical (observed) response frequencies by item response category. A statistically significant value indicates if the model corresponds to the given item.

**Table 3.** Item-Fit Statistics ( $S-\chi^2$  Item Level Diagnostic Statistics) for 14-Item Five-Category Scale.

Item	Label	$S-\chi^2$	d.f.	Probability
1	OC1	52.98	45	0.1931
2	OC2	59.02	49	0.1544
3	OC3	62.28	57	0.2932
4	PC1	113.15	68	0.0005
5	PC2	49.58	45	0.2951
6	PC3	56.72	45	0.1128
7	PC4	105.00	71	0.0054
8	RPP1	90.15	63	0.0140
9	RPP2	56.31	57	0.5019
10	RPP3	60.49	59	0.4228
11	LLD1	51.80	51	0.4436
12	LLD2	78.37	60	0.0557
13	LLD3	79.52	64	0.0912
14	LLD4	91.73	67	0.0241

Given, that the length of the scale is short, the statistics have been calculated at the 1% significance level. The items fit  $S-\chi^2$  statistics (see Table 3) and indicate the satisfactory correspondence except only 1 of the 14 items ( $p < 0.01$  for Item 4 (PC1)). Since the correspondence of the model to this item is not acceptable, then the Item 4 has been removed, and the IRT items calibration has been performed again, and tests of item level correspondence have proved (see Table 4).

**Table 4.** Final Item-Fit Statistics ( $S-\chi^2$  Item Level Diagnostic Statistics) for 13-Item Five-Category Scale.

Item	Label	$S-\chi^2$	d.f.	Probability
1	OC1	58.76	44	0.0673
2	OC2	58.82	44	0.0666
3	OC3	63.68	53	0.1493
4	PC2	92.06	70	0.0397
5	PC3	50.40	46	0.3028
6	PC4	51.25	43	0.1812



7	RPP1	92.60	67	0.0209
8	RPP2	99.31	64	0.0031
9	RPP3	48.39	50	0.5390
10	LLD1	55.26	59	0.6148
11	LLD2	53.19	52	0.4294
12	LLD3	61.37	60	0.4277
13	LLD4	67.20	58	0.1908

In this study, to analyze model-data correspondence respectively Graded and GPCredit models have been used and -2 LogLikelihood (-2LL) values have been gained for each model. -2LL values for each model are shown in Table 5.

**Table 5.** -2 Loglikelihood values for inter models

Graded	GPCredit
-2 Log Likelihood: 7782.93	-2 Log Likelihood: 7841.94

To determine which model is appropriate for our data structure, the difference between -2LL values have been analyzed if it is over than the desired value looking up at the  $\chi^2$  table. As there are 13 items in the test (after calibration),  $p=0.01$  desired value for  $\chi^2$  is 27.69. As it can be seen in Table 5 for the GPCredit and the Graded models, the difference between -2LL values is 59.01. As the gained value is over than the intended value, it has been determined that the Graded model is more appropriate for our data structure than the GPCredit model.

**Evaluating and Interpreting Results.** Given that the model assumptions are tenable, the description of the item properties, including the amount of information available, now we can apply for each item, subset of items, or the entire scale. The ITR model item parameter estimates for the 13-items scale are provided in Table 6.

**Table 6.** Graded Model Item Parameter Estimates, logit:  $a(\theta - b)$

Item	Label	$a$	$s.e.$	$b_1$	$s.e.$	$b_2$	$s.e.$	$b_3$	$s.e.$	$b_4$	$s.e.$
1	OC1	2.82	0.32	-0.92	0.13	0.31	0.09	1.33	0.12	2.41	0.22
2	OC2	2.22	0.25	-1.01	0.14	0.53	0.10	1.53	0.14	2.95	0.33
3	OC3	2.23	0.24	-0.94	0.14	0.18	0.10	1.15	0.12	2.29	0.22
4	PC1	1.01	0.15	-0.73	0.19	0.92	0.18	2.20	0.32	3.88	0.60
5	PC2	2.67	0.29	-1.16	0.14	0.13	0.09	1.33	0.12	2.65	0.26
6	PC3	1.55	0.20	-0.49	0.14	1.21	0.15	2.51	0.28	4.33	0.76
7	PC4	1.25	0.16	-2.37	0.32	-0.75	0.16	0.77	0.14	2.09	0.26
8	RPP1	1.72	0.20	-1.06	0.16	0.13	0.11	1.24	0.14	2.34	0.24
9	RPP2	1.75	0.22	-0.78	0.15	0.66	0.11	1.59	0.16	3.33	0.43
10	RPP3	1.46	0.19	-0.36	0.13	0.66	0.12	1.95	0.22	3.54	0.49
11	LLD1	2.37	0.26	-1.23	0.15	0.08	0.10	1.07	0.11	2.30	0.21
12	LLD2	1.83	0.21	-0.85	0.14	0.37	0.10	1.23	0.13	2.42	0.25
13	LLD3	1.23	0.18	-0.34	0.15	1.14	0.17	2.15	0.28	4.21	0.67

Parameter  $a$  is the slope;  $b_1, b_2, b_3, b_4$  present the ability to value at the thresholds between the response-option categories for the item. Each threshold reflects the level of generally perceived selfefficacy needed to have equal 0.50 probability by choosing

the corresponding above the given threshold. In our study there are 5 graded categories or response options, thus there are 4  $b$  values.  $b_1$  is the threshold for the trace line describing the probability of chosen category 2, 3, 4, or 5.  $b_2$  is the threshold for the trace line describing the probability of chosen category 3, 4, or 5.  $b_3$  is the threshold for the trace line describing the probability of chosen category 4 or 5.  $b_4$  is the threshold for the trace line describing the probability of chosen category 5. For example, to determine the probability that someone will choose category 2, we subtract the probability dictated by the trace line defined by  $b_2$  from that dictated by the trace line defined by  $b_1$ .

The slope estimates the range from 1.01 (Item 4) to 2.82 (Item 1). In general, all items have a two level relationship with general teachers' digital competency (first level slope values – from 1.01 to 1.83 and the second level – from 2.22 to 2.82). But the large level of slopes for Items 1-3, 5, 11 indicates that they have the strongest relationship with the latent trait and measure general digital competency more precisely than other items.

Threshold parameters for the Graded model correspond to the 13-item of five-category scale ranged from  $-2.37$  (Item 7) to  $-0.34$  (Item 13) for  $b_1$ , from  $-0.75$  (Item 7) to  $1.21$  (Item 6) for  $b_2$ , from  $1.07$  (Item 11) to  $2.51$  (Item 6) for  $b_3$ , from  $2.09$  (Item 7) to  $4.21$  (Item 13) for  $b_4$ . The majority of  $b_1$ ,  $b_2$ ,  $b_3$  and  $b_4$  thresholds for the items are around general digital competency level of  $-0.94$ ,  $0.43$ ,  $1.54$ ,  $2.98$ , respectively. The range of average values of the thresholds is wide enough and they differ by more than 1. This information implies that the used scale is the most useful in distinguishing between teachers around these latent trait levels.

Each item has its own item information function (IIF) that is shaped by its slope and thresholds. IIFs are used to identify how much empirical information each item adds to the entire scale and where that information appears along the continuum.

IIFs are readily available in the IRTPRO once the set of items have been calibrated.

Figure 2 [8] shows IIFs for 13 items from the five-category scale.

The information function of the ideal test must have one clearly expressed extremum. If the graph of the information function has a smooth, but not clearly expressed extremum, it suggests a decrease in the effectiveness of the entire test. In the case of several local extrema, for example, two at  $\theta_1$  and  $\theta_2$ , the test needs to be improved. If the number of items in the test is not big, then you need to add items that have an intermediate complexity  $\theta_1 < \delta < \theta_2$  to eliminate the "failures" between adjacent extremums.

The IIFs for Items 1, 2, 3, 5 and 8 stands out the most from all other items because it provides the most amount of information (precision). The maximum values IIFs of these items are in the range of 1.5 to 2.0. For instance, the IIF for Item 1 (OC1) has local extrema in four point  $\theta = -0.92$ ,  $\theta = 0.31$ ,  $\theta = 1.33$ ,  $\theta = 2.41$ , which are the item's respective thresholds  $b_1$ ,  $b_2$ ,  $b_3$ ,  $b_4$ . The items providing the least amount of information across the continuum are Items 4 (PC2) and 13 (LLD4) as their slope values were the lowest relative to all other items on the scale. There are pairs of items that appear to provide nearly identical information across the continuum because their respective IIFs are nearly identical, so that suggests that only one of these items may

be necessary. Such pairs are represented by the pairs of Items 3 and 11, Items 8 and 12.

To understand how the 13-item five-category scale works in the whole, the area under each IIF can be summed together to create a total information function (TIF). Each item contributes independently the unique information to the TIF and is not dependent on other items. This is also another reason why the assumption of LI is important. The TIF provides useful details about variable scale information on the trait continuum. Furthermore, the TIF can be used to identify gaps in the continuum.

Useful metric to capture the amount of error around an IRT score is the expected standard error of estimate (SEE;  $SEE \approx 1/\sqrt{\text{information}}$ ). The SEE can also be used as a function to gauge the expected amount of errors along the continuum.

Figure 3 [26] shows graphs for changing the basic data (measured in logits) and the standard error of measurement.

As it can be seen from Figure 3, with values  $\theta$  from -1.5 to 3.0, the SEE is almost constant and slightly less than 0.3, but the value of the information function is the range from 13 to 15 (approximately constantly). Then the estimated marginal reliability for this range is  $1-0.32^2 \cong 0.91$ . The Marginal Reliability for Corresponding Pattern Scores provided by the IRTPRO is 0.92. This means that for latent values greater than -1.5 the values of the indicator variables are the most reliable. However, outside this range of -1.5 to 3.0 marginal reliability decreases and the SEE increases. Thus, if a more precise GSE scale was desired within this range or across more of the continuum, then more items are need to be added to the scale to meet the desired information or level of expected SEE.

To summarize, the 13-item five-category scale provides precise estimates of the scores (information  $\cong 14$ , marginal reliability  $\cong 0.92$ , expected SEE  $\cong 0.3$ ) for a broad range of the continuum, -1.5 to 3.0. The maximum amount of information (precision) is approximately 15 around latent trait estimates 1.3. However, precision and expected SEEs around score estimates worsen outside of this range. To improve score estimates beyond this range it is need to write additional items that have thresholds below -1.5.

According to the IRT analysis, the following conclusions can be drawn:

1. Analyzing the characteristic functions (see Figure 1) of the questionnaire questions, it is possible to note that the probability of choosing the response of category 0 (very low level (initial level) for all 14 distractors (OC1, OC2, OC3, PC1, PC2, PC3, PC4, RPP1, RPP2, RPP3, LLD1, LLD2, LLD3, LLD4) with  $\theta = -3$  is within the approximate range from 0.75 to 1.0 (fairly high limits). This means that a small number of teachers assesses their level of digital competency according to all distractors at the initial level, which is a very positive factor at the present time. The higher the level of the teachers' digital competences, the smaller is the probability to choose from the category 0 a response, which is completely natural. For most distractors, the probability of choosing from the category 0 response falls to zero for teachers with an average level of competencies ( $\theta = 0$ ), the exception is for the PC1, PC3, RPP3, LLD3, LLD4 distractors, for which the probability of choosing a category response from 0 equals to  $\theta = -3$ . This means that the competencies that

correspond to these distractors are not yet well formed even among teachers with an average level of general digital competence.

2. The probability to choose a response from the category 4 (high level (expert level)) for all 14 distractors with  $\theta = 3$  is within the approximate range from 0.2 to 0.8. This means that teachers who generally have a high level of overall digital competence (or believe that it is of such a level), in the context of exact distractors, have a very miscellaneous level of preparedness. The attention should be paid to the development of competencies that correspond to distractors for which the corresponding probability is less than 0.5. These are PC1, PC3, RPP2, RPP3, LLD3, LLD4.
3. If the graphs of characteristic functions for categories 1, 2 and 3 reach their maximum somewhere in the middle of the scale from -3 to 3, then this is normal from the point of view of the IRT analysis. But as our study has revealed that the curve 3 for individual distractors (PC1, PC3, RPP2, RPP3, LLD3, LLD4) reaches its maximum at the right end of the scale for  $\theta$ . This means that teachers who are considered to having the high level of general digital competence, in fact, the level of their competence that corresponds to the specified distractors is not sufficient.
4. The particular concern is caused by the competences with responses from the categories 1, 2 and 3 have a less probability than 0.5 and when the maxima of these probabilities are shifted to the right. These are the competences: PC1, RPP1, RPP2, RPP3, LLD2, LLD3. The displacement of the maximum of probabilities, shifted to the right, means that teachers who are considered to have an average level of competences, in general, have an inadequate level of preparedness of these competencies.
5. From the above mentioned, the level that correspond to the OC1, OC2, OC3, PC2 and LLD1 distractors considered to be satisfactory from the point of probabilistic statistical analysis.
6. When analyzing S- $\chi^2$  Item Level Diagnostic Statistics, we came to the conclusion that the PC1 item should be removed from the questionnaire (see Table 3 and Table 4). Indeed, if we analyze Table 1 at the content level, the attention can be drawn to the fact that the PC1 and PC3 distractors concern in fact to one competence, which is realized in different activity directions.
7. The analysis of the information functions of the questionnaire (see Figure 2) shows that items PC2, RPP1 and LLD4 were not informative enough in the general context of digital competencies evaluation. In order to do the repeated research on general digital competence after the practical implementation of the strategy for its formation or individual stages of this strategy, these distractors should be corrected.
8. From the graph of the general information function (see Figure 3) it is clear that the IRT analysis gives the sufficiently complete information about the general digital competency of the teachers. Only in cases of very low competence or close to it the value of the general information function is low and according to it, the standard error of estimation (SEE) is high. This indicates the fairly good selection of distractors for this study.

### **3.3 Development of approaches to the development of digital competences of teachers in the process of their lifelong learning at Ternopil Volodymyr Hnatiuk National Pedagogical University**

From the study, it follows that teachers with different levels of digital competency of professional development do not have well-formed competencies such as: working with other educators to implement educational projects, joint development of educational resources, appeal to others to improve their digital pedagogical competence, provision learning opportunities for colleagues, the use of online learning opportunities.

Proceeding from this, approaches to the development of digital competencies in the process of improving of teachers' qualification at the training center "Educational Innovation" of Ternopil Volodymyr Hnatiuk National Pedagogical University were developed. They are based on a model for teaching teachers throughout their lives based on the development of digital competencies [1].

Proposed approaches to the professional development of digital competences of teachers in the process of their lifelong learning include groups of criteria for the planning and development of organizational communications, engagement and professional co-operation, assessment and reflexive pedagogical practice, sustainability, and professional development throughout life.

In the process of planning and developing organizational communications, attention is paid to both the contemporary national and world context and the individual experience of developing digital competences of teachers in the process of their professional development and lifelong learning, namely:

- combining a subject of the learning with context in which teachers work at the level of school, community, region;
- correlations of qualification improving on the development of digital competences of teachers in the process of their professional development and lifelong learning with standards, programs and goals at the school, community, region, and state levels;
- the use of digital technologies for communication of institution and teacher with other teachers and pupils.

The group of criteria for "engagement and professional co-operation" envisages an active role for teachers in professional co-operation, community building and motivation to share their pedagogical experience:

- collaboration with other educators for the implementation of educational projects;
- joint development of educational resources;
- supporting professional co-operation, providing learning opportunities of the learning for colleagues;
- the creation and development of professional communities with horizontal links to ensure mutual learning and discussion of new ideas;
- appealing for help to others to improve their digital pedagogical competence;

- searching study materials for continuing professional development, using online learning opportunities.

In the group of criteria "evaluation and reflective pedagogical practice" the emphasis is on formal assessment, qualitative feedback and constant reflection:

- demonstration of the service's compliance with the stated objectives and learning outcomes;
- the use of digital technologies for individual and collective reflexive pedagogical practice;
- feedback opportunities for those who take part in the improving of qualifications;
- discussion of specific features related to the received knowledge, materials or skills that will be demonstrated by a successful transition to the implementation of professional activities;
- adding participants to the assessment of their knowledge and skills.

The group of criteria for "sustainability and professional lifelong development" provides post-support, facilitates better motivation of educators for lifelong learning and helps in building an individualized trajectory of professional growth in the field of digital technologies, namely:

- detailing of further steps after training that teachers need to apply in a new environment;
- proposals for continuing education through information and technical post-support;
- provision of training opportunities for colleagues;
- use of online learning opportunities (massive open online courses, webinars, etc.);
- advising on the implementation of educational innovations.

These approaches are already being implemented in practice in the process of qualification improving of teachers and their lifelong learning at the international educational training center of Ternopil Volodymyr Hnatiuk National Pedagogical University.

## 4 Conclusions

To develop approaches to assessing the professional development of digital competences of teachers during their lifelong learning, levels of their formation were determined, as well as relevant criteria and indicators.

The results were processed based on the theory of modeling and parametrization of tests IRT. We can state the appropriateness of choosing the standardized statistics LD  $\chi^2$  and statistics  $M_2$ , presented in IRTPRO.

On the basis of the conducted research, the approaches to the professional development of digital competence of teachers in the process of their lifelong learning are proposed, which include the following groups of criteria: planning and development of organizational communications, engagement and professional cooperation, assessment and reflective pedagogical practice, sustainability and professional development throughout life.

Among the main vectors of the strategy of professional development of teachers in the context of the development of digital competencies, it should be noted: the creation and development of professional communities with horizontal links to ensure mutual learning and discussion of new ideas; the use of digital technologies and resources in the learning process, modeling of the learning process, oriented on results and educational projects.

## References

1. Balyk, N., Barna, O., Shmyger, G., Oleksiuk, V.: Model of Professional Retraining of Teachers Based on the Development of STEM Competencies, [http://ceur-ws.org/Vol-2104/paper\\_157.pdf](http://ceur-ws.org/Vol-2104/paper_157.pdf) (2018).
2. DigCompEdu, <https://ec.europa.eu/jrc/digcompedu> (2017).
3. DigComp 2.1: The Digital Competence Framework for Citizens with eight proficiency levels and examples of use, [http://publications.jrc.ec.europa.eu/repository/bitstream/JRC106281/web-digcomp2.1pdf\\_\(online\).pdf](http://publications.jrc.ec.europa.eu/repository/bitstream/JRC106281/web-digcomp2.1pdf_(online).pdf) (2017).
4. Edwards, M.: An Introduction to Item Response Theory Using the Need for Cognition Scale. *Social and Personality Psychology Compass*, 3(4), pp.507–529 (2009)
5. European Commission. Key competences for lifelong learning. A European frame of reference. Luxembourg: Office for Official Publications of the European Communities, <http://www.mecd.gob.es/dctm/ministerio/educacion/mecu/movilidad-europea/competenciasclave.pdf?documentId=0901e72b80685fb1> (2007).
6. Ferrari, A.: DIGCOMP: A Framework for Developing and Understanding Digital Competence in Europe; Publications Office of the European Union: Luxembourg, Volume EUR 26035, <http://publications.jrc.ec.europa.eu/repository/bitstream/JRC83167/lb-na-26035-enn.pdf> (2013).
7. From, J.: Pedagogical digital competence – between values, knowledge and skills. *Higher Education Studies*, 7(2), pp.43–50 (2017).
8. Graded response model item information functions for 13 items scale, [https://drive.google.com/file/d/1-4yQ\\_vNRmBVHHySp9mBimWtq8IGTVe4X/view](https://drive.google.com/file/d/1-4yQ_vNRmBVHHySp9mBimWtq8IGTVe4X/view) (2019).
9. Gudmundsdottir, G., Loftsgarden, M., Ottestad, G.: Nyutdannede lærere: Profesjonsfaglig digital kompetanse og erfaringer med IKT i lærerutdanningen. Senter for IKT i utdanningen. (2014).
10. Hall, R., Atkins, L., Fraser, J.: Defining a self-evaluation digital literacy framework for secondary educators: the DigiLit Leicester project. *Research in Learning Technology*, 22 (2014).
11. Hargreaves, A.: *Teaching in the knowledge society: Education in the age of insecurity*. New York: Teachers College Press. (2003).
12. Hatlevik, O. E.: Examining the relationship between teachers' self-efficacy, their digital competence, strategies to evaluate information, and use of ICT at school. *Scandinavian Journal of Educational Research*. 61(5), pp.555-567 (2017).

13. Lund, A., Furberg, A., Bakken, J., Engelién, K. L.: What does professional digital competence mean in teacher education? *Nordic Journal of Digital Literacy*, 9(4), pp.281–299 (2014).
14. Martin, A., Grudziecki, J.: DigEuLit: concepts and tools for digital literacy development. *Innovation in Teaching and Learning in Information and Computer Sciences*, 5(4). pp.249-267 (2006).
15. ORF for Items 1-14, <https://drive.google.com/file/d/1vW62WETrp1H41vRuyJJBXwLeIDS77w0/view> (2019).
16. Ottestad, G., Kelentrić, M., Guðmundsdóttir, G.: Professional Digital Competence in Teacher Education. *Nordic Journal of Digital Literacy*, 9, pp. 243-249 (2014).
17. Paek, I., Han, K.: IRTPRO 2.1 for Windows (Item Response Theory for Patient-Reported Outcomes). *Applied Psychological Measurement*, 37, pp. 242-252 (2013).
18. Pettersson, F.: On the issues of digital competence in educational contexts – a review of literature. *Education and Information Technologies*, 23(3), pp. 1005–1021 (2018).
19. Pozos P., Torelló O.: The digital competence as a cross-cutting axis of higher education teachers' pedagogical competences in the european higher education area. *WCES 2012. Procedia – Social and Behavioral Sciences*, 46, pp.1112 – 1116 (2012).
20. Proposal for a Council Recommendation on Key Competences for Lifelong Learning, Brussels, <https://ec.europa.eu/education/sites/education/files/recommendation-key-competences-lifelong-learning.pdf> (2018).
21. Shmyger, G., Balyk, N.: Formation of Digital Competencies in the Process of Changing Educational Paradigm from E-Learning to Smart-Learning at Pedagogical University. In E.Smyrnova-Trybulska (Eds.), *Monograph «E-learning Methodology – Effective Development of Teachers' Skills in the Area of ICT and E-learning»*, 9, pp. 483 – 497 (2017).
22. Shyshkina, M.: Emerging Technologies for Training of ICT-Skilled Educational Personnel. In: Ermolayev, V., Mayr, H.C., Nikitchenko, M., Spivakovsky, A., Zholkevych, G. (ed.) *Information and Communication Technologies in Education, Research, and Industrial Applications. ICTERI 2013. Communications in Computer and Information Science*, 412, pp. 274-284, [https://link.springer.com/chapter/10.1007/978-3-319-03998-5\\_14](https://link.springer.com/chapter/10.1007/978-3-319-03998-5_14) (2013).
23. Spirin, O., Nosenko, Yu., Iatsyshyn, A.: Current requirements and contents of training of qualified scientists on information and communication technologies in education. In: *J. Information Technologies and Learning Tools*, 56(6), <http://journal.iitta.gov.ua/index.php/itlt/article/view/632/483> (2016) (in Ukrainian)
24. Tømte, C., Kårstein, A., Olsen, D.: *IKT i lærerutdanningen. På vei mot profesjonsfaglig digital kompetanse?* Oslo: NIFU. (2013).
25. Tømte, C. Digital competence in teacher education. *Learning & Teaching with Media & Technology*, pp. 173-182. (2013).
26. Total information function and expected SEE function, [https://drive.google.com/file/d/11eiFVcS96DDthG6uR7yY0UE34BNsLk\\_I/view](https://drive.google.com/file/d/11eiFVcS96DDthG6uR7yY0UE34BNsLk_I/view) (2019).
27. Wastiau, P., Blamire, R., Kearney, C., Quittre, V., Van de Gaer, E., Monseur, C.: The use of ICT in education: A survey of schools in Europe. *European Journal of Education*, 48(1), pp. 11–27 (2013).



# Information System of Scientific Activity Indicators of Scientific Organizations: Development Status and Prospects

Aleksandr Spivakovsky <sup>[0000-0001-7574-4133]</sup>, Maksym Vinnyk <sup>[0000-0002-2475-7169]</sup>,  
Maksym Poltoratskiy <sup>[0000-0001-9861-4438]</sup>, Yulia Tarasich <sup>[0000-0002-6201-4569]</sup>,  
Yevheniia Spivakovska <sup>[0000-0002-7974-4736]</sup>, Greg Gardner  
and Kateryna Panova

Kherson State University, 27, Universytets'ka St., 73000 Kherson, Ukraine

{Spivakovsky, Vinnik, KPanova, Spivakovska}@ksu.ks.ua,  
{YuTarasich, mpoltorackiy, gardnega}@gmail.com

**Abstract.** Nowadays ICT are one of main ways to arrange and create effective tools for organizing the interaction and processing large amount of information. In our opinion, information of university's scientific activity should be presented in the rating form, which gives an opportunity to analyze development in different directions and changes.

The key idea of the article is presenting of our experience in developing rating system for universities based on scientist's scientometric indices.

The system provides open data from different scientometric systems, such as Google Scholar, Scopus, Web of Science and Semantic Scholar.

The possibility of automatical construction of a rating of scientists, research groups and organizations (as well as their structural subdivisions) is described.

**Keywords:** scientific activity, information systems, scientometric systems, bibliometric systems, scientometric indicators, automatic ratings.

## Introduction

The criteria for evaluating the effectiveness of fundamental scientific research can be divided into qualitative and quantitative indicators. Today in Ukraine, in the process of evaluating of the effectiveness of science, scientometric indicators are being used increasingly both to evaluate the work of an individual scientist, research teams, organizations and scientific publications. For example, it is necessary to indicate the number of publications and the number of citations over the past five years, as well as the Hirsch index in the tender documentation for submitting applications for grants for research activities, for the passing a competition for teaching positions in an educational institution, for drawing up reports of the scientific activities of departments and faculties, for reports on the work of graduate students, for passing accreditation of specialties, departments, etc.

And this information must be described for each database, such as Web of Science, Scopus, Google Scholar.

Scientometric indicators are also used to assess the quality of scientific journals. In this case, the indicators of the editorial board, and, in fact, published publications and issues, their openness and accessibility to the scientific community are taken into account.

Each of the indices has its own criteria for the selection of scientific publications and the inclusion of publications in the database, its specific calculation of scientometric parameters. If the rules for selecting journals in WoS and Scopus indices are now the most stringent, then Google Scholar's system, on the contrary, is the most extensive system, that collecting all scientific publications on the Internet, including open access repositories, personal pages of scientists and university electronic libraries. And if we take into account and analyze many other scientometric systems, we get a whole set of various indicators and only after their general analysis we'll can to give a correct assessment of scientific activity. Therefore, the problem of building consolidated ratings is remains relevant.

As shows a practice, the collection and analysis of this kind of information is a very hard and lengthy process that needs automation and optimization. Previously, the authors of the article had already considered the requirements for the system of scientific activity indicators of scientific organizations, and also described the basic functionality of the first version of such a system.

This article describes the new features of the system, its current state and the results of its use in higher education institutions.

## 1 Related works

A big number of the recently created scientometric services allow assessing the relevance of the research results by a scientist, the number of his publications, citations, etc. The most outstanding services with rapidly growing impact are Google Scholar, Scopus, Orcid, Academia.edu, Research Gate, Mendeley, arXiv.org, cs2n, Epernicus, Myexperiment, Network.nature, Sciencecommunity.

The main interesting information systems that run on the activities of scientists, scientific groups, publishers, etc..., are:

Bibliometrics of Ukrainian Science [1].

The system "Bibliometrics of Ukrainian Science" is representation of information of Ukraine scientists' profiles who provided information about their publication in the Internet; national component of the project Ranking of Scientists (Cybermetrics Lab).

Scopus. Scopus system is designed to maintain efficient workflow of researchers, helping them to: find new articles from the area of their specialization; find information about the author; analyze the publication activity in the subject area; track citation; view the h-index; identify the most cited articles and authors; assess the relevance of the study [2,6].

Google Scholar. Google Scholar is freely accessible search system, which indexed the full text of the scientific publications all formats and discipline [3].

Web of Science. Web of Science – International established database of Scientific Citation, it is presented by company Thomson Reuters. In addition to search of scientific publications, Web of Science establishes a reference link between the specific research using the cited materials and thematic links between articles established reputable researchers working in this field [4].

But all of them can't to resolve such problems, as

- the absence of a clear mechanism of evaluation of personal contribution of the scientist in the scientific work of his organization,
- the incomprehension of the construction of university decisions related to scientometric.

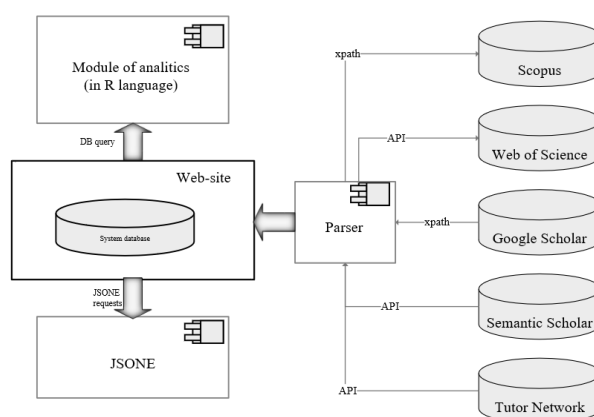
In addition, today, the analysis of the scientific indicators of scientists' group, organization and its department, is carried out manually. The only option of its partial automation is rating the organization's profile in Google Scholar.

In addition, this article is a continuation of the previous works of the authors [8-10] which addressed the issue of openness of scientific activities of Ukrainian scientists, as well as the construction of an open scientific training system, one of the main elements of which are the scientometric information processing system.

## 2 System description

The main task of building our system is the realization of the possibility of automatic processing of scientometric and bibliometric indicators of scientific organizations on the basis of analysis of scientific profiles of scientometric databases and systems, including automatic search and its analysis.

The high-level system architecture is shown in Fig. 1.



**Fig. 1.** The interaction of key system components

As you can see in Fig.1, the main components of the system are: Parser, Module of analytics, JSONE module, system Web-site, databases.

Parser is using for search, receiving and transfer the open information of scientometric indicators of authors and journals provided by Scopus, Web of Science, Google Scholar, Semantic Scholar and Tutor Network. For interaction with Scopus and Google Scholar parser uses xpath queries, and API is used for getting information from Web of Science and Tutor Network.

All data received by parser is stored in the system database. DB of system is distributed by the data storage. Individual entities of DB are database of scientometric indicators of researcher and scientific publications.

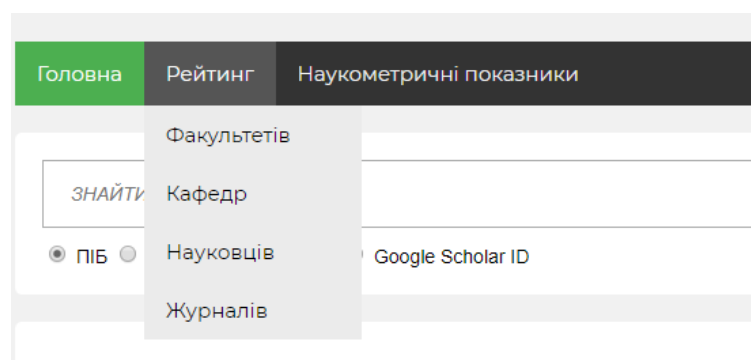
Information processing is realized by performing a set of predefined SQL queries.

Module of analytics (based in R language) provides an opportunity to get diagrams present data showing relation between different scientometric indicators, as the value of h-index in Scopus and the number of papers in Scopus or Google Scholar [11].

Tools and technologies thus were used for developing of the system were described more detail in previous articles [8, 10].

In the current version of the system we determined next forms of presentation of the results of analyzes of scientist's activities indicators (Fig.2):

- profiles of the scientists of the university with generalized information of scientometric indicators for each database, table of scientists articles and their availability in the scientometric systems;
- the rating list of all the scientists of organization;
- the rating list of all the scientists of organization's structural subdivision (faculty or department);
- the rating list of all scientific journals of organization;
- the general scientometric information about the university.



**Fig. 2.** Forms of presentation of the results of analyzes of scientists activities indicators

Lets consider the examples of building ratings.

1. Rating of scientists (Fig.3).

It is possible to display ranking lists of scientists according to data from such systems as Scopus, Web of Science, Google Scholar, Semantic Scholar, and also sorted data by the increasing (descending) of such indicators as – number of publications, citation, h-index.

It should be noted the presence of color indicators of publication activity (displayed as a line of a certain color near the name of the scientist):

- blue — the number of documents is over 10;
- green — the number of documents is in the range of 5 to 10 (inclusive);
- yellow — the number of documents is in the range from 1 to 4 (inclusive);
- red — no documents aren't included in such database.

ПІБ	Індекс Хірша	Документи	Цитування
Ермолаєв Вадим Анатолійович	7	64	217
Кобець Віталій Миколайович	4	30	36
Львов Михайло Сергійович	4	21	41
Песчаненко Володимир Сергійович	3	26	36
Бистрянцева Анастасія Миколаївна	3	8	14
Полторацький Максим Юрійович	3	7	16
Співаковський Олександр Володимирович	2	27	10
Вінник Максим Олександрович	2	10	15
Одінцов Валентин Володимирович	2	9	18
Кушнір Наталя Олександрівна	2	8	11

**Fig. 3.** Rating of scientists

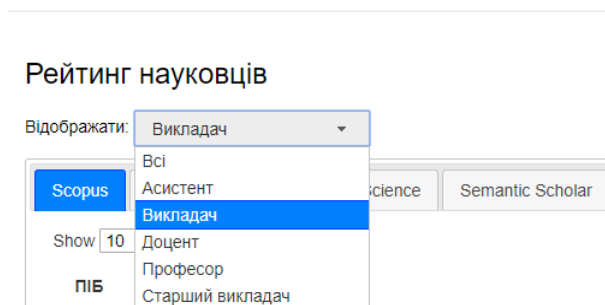
Ratings of scientific collectives, organisations and their departments (Fig.4)

Рейтинг кафедр

Кафедра	Індекс Хірша
Кафедра інформатики, програмної інженерії та економічної кібернетики	7
Кафедра алгебри, геометрії та математичного аналізу	3
Кафедра фізики та методики її навчання	2
Кафедра педагогіки дошкільної та початкової освіти	1
Кафедра інструментального виконавства	0
Кафедра історії та теорії національного і міжнародного права	0
Кафедра історії, археології та методики викладання	0

**Fig. 4.** Example of the rating of the department

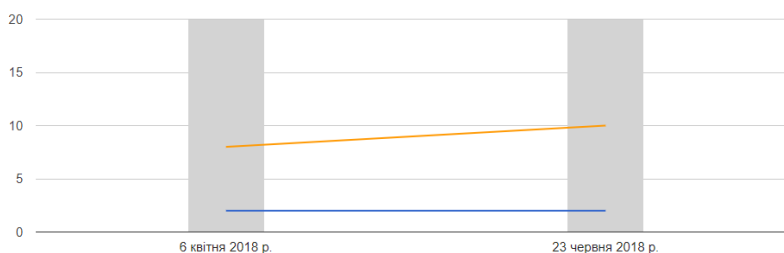
Also, like as in the previous version, in this version of the system is the opportunities to present data by such categories as students, assistants, teachers, professors, and etc. (Fig.5).



**Fig. 5.** Choosing of the rating type

Personal page of the scientist provides the following information:

- author’s general information (full name, name of the institution, faculty and department);
- information of author’s scientometric indicators for Scopus, Google Scholar, Web of Science and Semantic Scholar (for each separately), such as numbers of articles, citation, h-index;
- special diagrams that represents the dynamics of the growth of scientist’s number of documents, h-index and citation index for each of the scientometric systems (Fig.6);



**Fig. 6.** A diagram displays the growth of author’s scientometric indices

- Gray columns – the number of documents.
  - Blue line indicates the value of the h-index.
  - Yellow line indicates the value of citation index.
  - Under each column, the date of the verification of scientometric indices is indicated.
- scientist’s ORCID ID;

- the list of scientist's articles with marks that show their availability in the scientometric systems (Fig.7).
- the diagram of scientists coauthors (Fig.8)

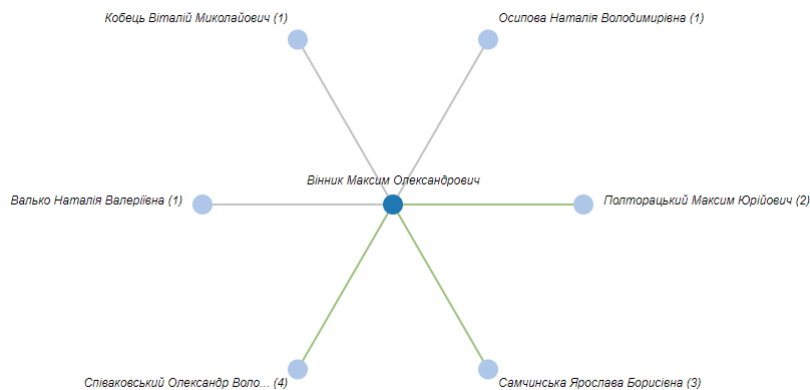
Статті

Show  entries

Search:

Зарплаток	Scopus	Google Scholar	Web of Science	Semantic Scholar
What can economic experiments discover about evolutionary e			+	
Web of Science			+	
Using an evolutionary algorithm to improve investment strateg	+	+		
TARIFF POLICY OF TRANSPORT COMPANY-MONOPOLIST PRODUCERS TO n MARKETS			+	
Simulation agent-based model of heterogeneous firms throug	+	+	+	
Nonlinear Dynamic model of a microeconomic system with diff Stability and bifurcations	+	+		
Neuro-fuzzy model of development forecasting and effective a	+	+		

**Fig. 7.** The list of scientist's articles

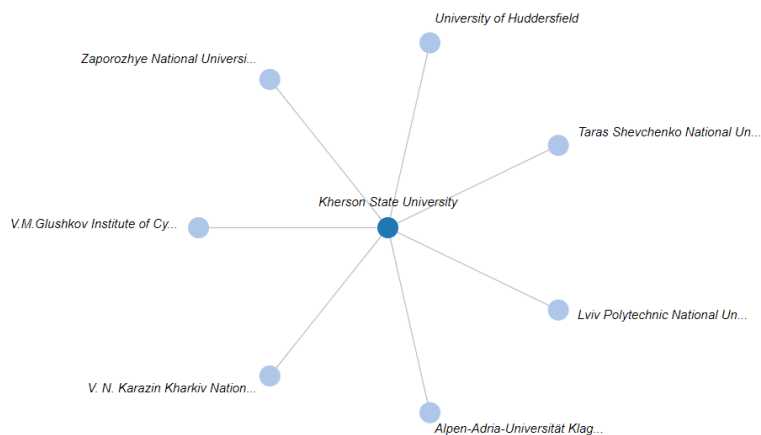


**Fig. 8.** The diagram of scientists coauthors

As you can see in Fig.8, the line that connects the scientist with his coauthor has a certain color:

- Blue – if scientists have only one general article,
- Green – if the number of such articles are from two to five,
- Violet – if more than 5 publications was written in co-authorship.

The number of general publications is indicated in brackets after the co-author's name. Also we can build the semantic network of partners of organization (Fig. 9):



**Fig. 9.** Example of semantic network of partner universities of Kherson State University

## Conclusions

Today we have developed and implemented new version of information system of scientific activity indicators of scientific organizations. The main capabilities of it are:

- automatic work with scientometric databases (algorithm of automatically search for links to profiles of Ukrainian scientists, algorithm of automatic distribution profiles of scientists on the name of the organization in which they work);
- automatic analyze of getting information;
- automatic generation of ratings of scientific organizations, their departments, scientists, scientific journals, etc;
- ability to send messages to e-mail scientists about changes of academic indexes.

Experience of using of such system show that we have a new opportunities for work with scientometric data, for they collection and analyzes. The graphical and table representation of statistical data makes the process of perception of information easier.

Data source of the system is open information, provided by such scientometric systems as Scopus, Google Scholar, Web of Science, Semantic Scholar and Tutor Network.

Today this system was implemented and tested on the base of Kherson State University and Kherson State Maritime Academy.

It's using to build a consolidated rating of scientists and structural units of these universities.

The next steps of the study is the development of Multilanguage system, analyses and improvement of the systems module that building the rating of scientific journals.



## References

1. Bibliometrics of Ukrainian Science, [Http://nbuviap.gov.ua/bpnu/index.php?page\\_sites=pro\\_proect](http://nbuviap.gov.ua/bpnu/index.php?page_sites=pro_proect)
2. Abstracts database Scopus, [http://health.elsevier.ru/electronic/product\\_scopus/](http://health.elsevier.ru/electronic/product_scopus/)
3. Scientometric database, <http://www.nbu.gov.ua/node/1367>
4. Science Citation Index for scientists, <http://index.petrus.ru>
5. Allen Institute for Artificial Intelligence: Semantic Scholar, <https://www.semanticscholar.org/>
6. Elsevier: The largest database of peer-reviewed literature, <https://www.elsevier.com/solutions/scopus>
7. Hartley, R., Barnden, J.: Semantic Networks: Visualizations of Knowledge. Computer Science: New Mexico State University, <https://www.cs.nmsu.edu/~rth/publications/TICS.pdf>
8. Spivakovsky, A., Vinnik, M., Poltoratskiy, M., Tarasich, Y., Panova, K., Melnychenko, A.: Development of Rating Systems for Scientometric Indices of Universities. ICT in Education, Research and Industrial Applications: Integration, Harmonization and Knowledge Transfer: Proceedings of the 14th International Conference ICTERI 2018. Vol. 2104, pp. 420-430. CEUR-WS.org (2018).
9. Spivakovsky, A., Vinnyk, M., & Tarasich, Y.: Web Indicators of ICT Use in the Work of Ukrainian Dissertation Committees and Graduate Schools as Element of Open Science. Information and Communication Technologies in Education, Research, and Industrial Applications. ICTERI 2015. Communications in Computer and Information Science. Vol 594., pp. 3-19. Springer, Cham (2015).
10. Spivakovsky, A., Vinnyk, M., Tarasich, Y., Poltoratskiy M.: Design and development of information system of scientific activity indicators. ICT in Education, Research and Industrial Applications: Integration, Harmonization and Knowledge Transfer. Proceedings of the 12th International Conference ICTERI 2016, vol. 1614, pp. 103-110. CEUR-WS.org (2016).

# Advanced Information Technology Tools for Media and Information Literacy Training

Yuliya Krylova-Grek <sup>[0000-0002-2377-3781]</sup>

The State University of Telecommunications, Solomenska Street, 7, Kyiv 03680, Ukraine  
docal23@ukr.net

**Abstract.** Media and information literacy is an essential skill in the Digital Age. Indeed, the lack of knowledge and skills in media literacy is one of the reasons people are unable to analyse and evaluate information, thus creating a fertile breeding ground for unfair use of the World Wide Web. These days, people use information technologies to develop necessary insights and mindsets in order to appreciate adequately the overwhelming amount of information. Our purpose-designed Media and Information Literacy course lies at the core of freedom of expression and information. Prioritized information technologies empower learners to understand the functions of online resources, to critically assess their content, and to make decisions as users and producers of information and media content. The benefits from these technologies are obvious. They are extremely affordable, and the devices to implement them are always at hand.

This paper is in response to a call for input to a study of media and information literacy at the State University of Telecommunication (Kyiv, Ukraine). It covers the issues of applying information technologies to study media literacy. The effective implementation of the course is based on the author's unique approach, which includes the active use of a "media-creator" computer game, fact-checking methods, and special software. The media and information literacy course is regarded as a set of steps, as manifest in the paper. The obtained results demonstrate that having attended an array of classes, having learnt theory, and having fulfilled practical tasks, students become more informed, sensitive, and aware of the information they receive on the Internet.

**Keywords:** Information technology, Technical device, Online resource, Media literacy skills, Fact checking.

## 1 Introduction

Information technology has become a vital and integral part of daily life. The rapid process of informatization has saturated all spheres of our life, including education. It should be noted that new technologies include useful tools. As one would expect, they create favourable conditions for learning, since the classroom does not require special or complex equipment.

The huge amount of information that I get via the Internet makes the issue of media and information literacy relevant to our modern digital society, where the creation, distribution, use, integration, and manipulation of information is a key economic, political, and cultural activity. A large amount of information is one of the reasons leading to a superficial perception of information. In turn, this great amount results in many users' inability to distinguish true facts from manipulations and subjective judgments. According to UNESCO's international experts, the lack of knowledge and skills to analyse information make up a hidden threat to security and stability in society [1].

In February 2018, Kyiv International Institute conducted a sociological survey that captured the views of 2,043 Ukrainian residents. The survey contained certain questions on media literacy, which had the following results: About 52% of respondents did not verify the information they get from the media; however, 53% of those polled were sure that in most cases they were able to distinguish fakes from actual facts. Among the key identification credentials, respondents named media credibility and the author of the message [2].

The sociological data proves that respondents have a low level of knowledge of media literacy issues and a lack of practical, information-verifying skills.

The lack of media and information literacy creates a fertile breeding ground for unfair use of the web, including the distribution of false or manipulative content. However, the same online technologies can assist in developing the necessary skills for conscious perception and processing of online messages. Therefore, the main objective of our course is to teach students actionable ways they can verify information's accuracy, applying information technologies.

UNESCO defines media and information literacy as "a composite set of knowledge, skills, attitudes, competencies and practices that allow one to effectively access, analyse, critically evaluate, interpret, use, create and disseminate information and media products with the use of existing means and tools on a creative, legal, and ethical basis". It is an integral part of "21st century skills" or "transversal competencies" [3].

Computer-mediated communication includes social networks, blogs, online newspapers, and so on. They produce a huge number of messages whose truth or falsehood is difficult to grasp without particular skills. Therefore, knowledge and orientation skills in the information space are exceptionally urgent at the present time. Additionally, such skills are extraordinarily valuable during war time, crises, or other resonant events, since the ability to think critically reduces one's risks of being manipulated in society.

In this study, I focus on the use of technical devices, as this is the most accessible way to analyse and verify Internet information that does not require additional equipment. Portable devices are an integral part of most people's routine, as personal devices and gadgets serve to perform crucial informative and communicative functions. Moreover, modern technical devices make education and learning possible anywhere and at any time.

The skill of correctly using online resources, including understanding the structure of creating media messages, enables to take conscious advantage of modern infor-

mation and communication resources and not to become a victim of manipulation, misinformation, or social engineering. Therefore, our goal is to teach students to use information sources and means of communication responsibly and consciously, to prepare them for new conditions in their future work, to teach them to apply the capabilities of information technologies, to develop the skill of quick information analysis and verification, and to avoid manipulative people who have mastered the art of deception on the web.

## 2 Previous Studies

The question of the conscious use of online information has become extremely urgent in the 21st century, since manipulations and distorted facts have caused a wide range of national conflicts and confrontations. For example, according to Freedom House report, online manipulation and disinformation have been used in at least 18 countries during elections in recent years [4]. In her report, Viviane Reding, the EU Information Society and Media Commissioner, laid stress on the statement that people need a greater awareness of how to express themselves effectively, and how to interpret what others are saying, especially on blogs, via search engines, or in advertising [5].

Jesus Lau expressed a thought that information processing skills in the informative and communicative sphere increase the level of critical thinking, develop media literacy, and contribute to understanding the structure of information and communication processes in the modern world [6].

Issues related to the study of media and information literacy are viewed through the development of critical thinking (A.Dorr [7], L.Masterman, [8], R.Paul, L. Elder [9], B.Parry, J.Potter, C.Bazalgette [10], K. Tyner [11], C.Worsnop [12]); understanding the structure of the media (D. Frau-Meigs [13], D.Buckingham [14], A.Hart [15], Y.Krylova-Grek [16]); and media psychology (D.Giles [17], P.Rutledge [18], H.Asrafi-rizi, Z.Gh.Khorasgani, F.Zarmehr, J.Peña [19], L.Naydenova [20]).

At present, a variety of media literacy courses are being developed all over the world. Each of them has its own peculiarities and modifications, based on the intended age group and on the teaching methods.

For instance, Prof. Divina Frau-Meigs, one of the leaders of the movement in modern media education, has discussed the special importance of education in the information and communicative sciences. She emphasized the fact that disinformation and the lack of elementary analytical skills can become the cause of misunderstandings and conflicts. Her media literacy course MOOC DIY EMI is based on this approach, and it includes role playing to evaluate the work of the media from a professional point of view. When scrutinizing a certain media product, group members are divided into researchers, analysts, and content creators [13].

In the run up to the 2019 Ukrainian presidential election, International Research & Exchanges Board (IREX) designed a special, one-time media literacy project aimed at developing orientation skills for use with pre-election information [21]. Project «Media literacy program for citizens» was implemented with support of the Department of

Foreign Affairs, Trade and Development (DFATD Canada) together with the Academy of Ukrainian press, IREX and StopFake [22].

The recommendations do not include the practical use of information technologies; however, I strongly believe that the skill of checking information quickly using modern tools is an important component of media and information literacy.

The integration of technical devices into the learning process results in not only increasing its effectiveness but also made possible the implementation of alternative forms of study, such as Blended Learning, E-Learning, and Online Learning.

The study of the implementation of mobile internet devices was covered in the works of Ng. Wan, H. Nicholas, S. Loke, & T. Torabi [23-24], J. Herrington, N. Ostashewski [25], J. Traxler [26], A. K. Katrina [27], L. Kolb [28], J. Keengwe [29]. The researchers also consider the use of technical devices in online education and Blended education A. Kitchenham [30], D. Parsons [31-32], L. Chao [33].

D. Parsons thinks that utilizing available digital resources significantly enhance students' learning experiences. In his works, he showed the benefits of technological tools in contemporary classrooms. According to his point of view, the use of technical devices in blended learning leads to improved learning outcomes [31].

Talking about the positive side of Ng. Wan emphasized that ubiquitous learning is able to situate the learner in both the real and virtual world, regardless of time and place, where questions encounter. The student can immediately find the answer by accessing and conducting research on the Internet [23].

According to A. Kitchenham, mobile learning (m-learning) can take place in any environment using technologies that fit in the palm of the hand or can be easily carried from one place to another. He said about the advantages of implementing m-learning into blended learning practices [30].

As can be seen from the above, the effectiveness of using technical devices in the learning process is proven by numerous research. That is why we think that the integration of mobile internet devices will improve the effectiveness of media literacy education.

According to UNESCO's definition, "media education is associated with all types of media (print, graphic, sound, screen and other formats) and various technologies. It helps people to understand how mass communications are exploited in their societies, to master skills of using media in communication with other people", etc. [34].

Media literacy has also been popularized through online distance media literacy courses on learning platforms like Prometheus, WOMO, etc. However, such methods have a number of disadvantages associated with a volitional sphere. For example, learning a course requires stronger organizational skills and more self-discipline. Therefore, I insist on using direct contact with the audience to improve work efficiency.

### **3 Research Data**

After analysing the existing media literacy courses, I noted that their common feature is the use of theoretical and creative tasks aimed at developing critical thinking. How-

ever, most do not consider the issues related to the use of technical devices for quick information analysis and processing for media literacy education.

The development of quick information processing skill is a primary goal in today's society, when the news feed is constantly being updated, multiply times per day. Therefore, I formulated the following hypotheses: The use of technical means increases the effectiveness of media and information literacy training, develops skills of rapid information analysis, and promotes the use of critical thinking while reading media content.

Our study is aimed at confirming the hypotheses put forward and at manifesting the role of modern information technology for the development of media and information literacy skills that can be used by students in any place and at any time.

The benefits of these technologies are obvious. They are extremely affordable, and the devices to implement them are always at hand. I distinguished technical devices according to 1) The personal Mobile Internet Devices or Internet gadgets, such as Pocket PC, and smartphones; 2) Tablet PC such as Ultra Mobile PC, Internet tablets, Web tablet [35]. I recommend these devices because the following features characterize them: usability, lightweight, a small size, a long battery life, and high resolution. These features made them convenient and ease of use, so people may find the information they need anywhere. Therefore, I use the high tech approach to learning utilizes different technology to aid students in their media literacy learning.

The training course "Media and Information Literacy" employs technical tools to develop skills for quick and rapid analyzing, processing and verification information and for the development of the skills of spotting manipulations in media content.

I applied the following methods in order to collect data: questioning, testing, interviewing, analysing results, and processing the obtained statistical data. The teaching methods include explaining, demonstrating, collaborating (discussions, group work, role-play game, practice by doing).

The classes were held on the campus of the State University of Telecommunications (Kyiv, Ukraine) in December 2018. The classes were attended by first-year students of Information Security Department and second-year students of Information Technologies Department. Their total number was 104. Students were divided into 5 groups: three groups included 20 students each, one group consisted of 21 students and one group consisted of 23 students.

The complete course included five 40-minute lessons, which was perfect for working out media and information literacy skills using students' personal technical equipment, such as smart phones, tablet PCs, and computers.

During the very first lesson, I conducted a survey to find out the students' self-assessed level of knowledge about media and information literacy. The multiple-choice questionnaire consisted of a stem and several alternative answers.

The survey showed that 59.6% of respondents were sure that they were able to distinguish between true and false information, and 24.5% believed that they were able to distinguish fake news in most cases.

Thus, 84.1% of students were sure that in most cases they were able to notice deception and manipulation contained in informational messages. And therefore, in their opinion, they were unlikely to become victims of manipulation.

Additionally, only 6.7% of the respondents were convinced that they would not recognize fake news, and 9.2% doubted that they would be able to distinguish misinformation from the truth. Thus, only 15.2% doubted their ability to distinguish between the truth and false information.

However, as further research demonstrated that 67.9% considered their intuition to be the key criterion for evaluating the truth or falsity of the message, while 23.2% of respondents completely relied on the information posted by their friends on social networks. It is noteworthy that only 5.7% of young people tried to check information in other sources, and 3.2% were not interested in news at all.

It should be noted that only 6 students (5.7%) tried to verify the veracity of messages using Internet resources. Thus, the results of the first stage proved the expediency and necessity of conducting further classes (see Fig.1).

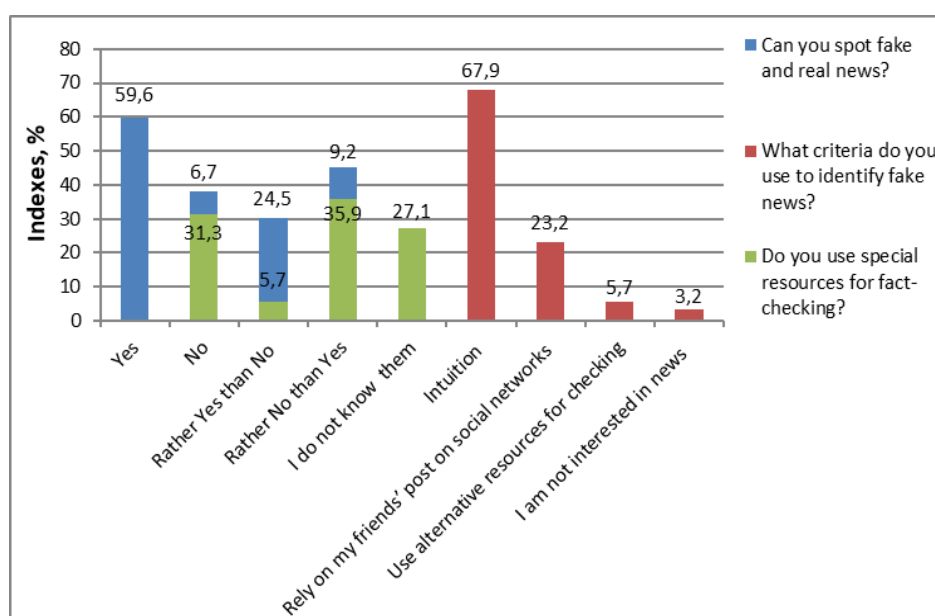


Fig. 1. The level of media literacy self-assessment before the training.

The second part of the lesson was conducted in the form of a test game “True-False”. Students were offered short messages to be evaluated for truth or falsity. The results showed that only 21.2% of the students were able to give the correct answers in most cases (by most I mean more than 50% of the correct answers). 60.9% could not give the correct answers in the majority of cases, while 17.9% found it difficult to answer.

Thus, the difference between confidence in one’s own media literacy and the actual situation is 62.9%. This result indicates that more than half of the students did not know how to check and analyse information messages and that they had a rather low level of media literacy (see Fig. 2).

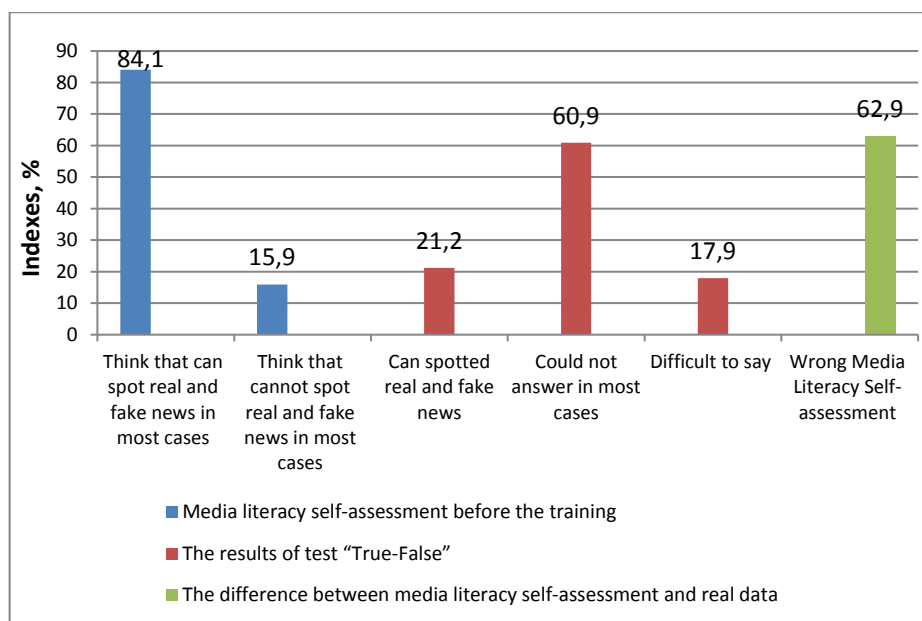


Fig. 2. The difference between students' confidence in their own media literacy level and the actual situation.

The goal of the next lesson was to introduce methods and technologies that allowed them to check information and facts for truth or falsity. To achieve this, I systematized the existing online resources, selecting the most simple and effective to use. In class, students practiced using resources to verify the information offered. One of the main recommendations was to check by using different sources, which made it possible to compare and analyse information to distinguish personal judgments from facts.

Because there are frequent cases of people using photographs that have nothing to do with the event that the photos illustrate, it is important to relay the time and place where a photo was taken along with the other information associated with the photo. The easiest way to find an image is using Google Chrome, which allows users to check whether photos or videos have been used before and under what conditions. For those using Firefox, I suggested using the "Who stole my pictures" resource [36].

The other examples of resource are the following FactCheck - resource for checking information in English [37]; VoxUkraine — independent analytical platform [38]; Foto Forensics is an online resource for determining error level analysis (ELA): modified or added details. Using the software, one can get EXIF-data as well. [39]; Findexif.com is an online resource used to check photos taken in the EXIF format, which allows getting data about when and where a photo was taken [40]; Pipl.com can be used in case one needs to check who exactly is distributing information. The given resource is especially useful for social networks. It should be noted that the software is included in the search engine of American-based social media networks, such as Facebook, LinkedIn, MySpace etc. [41].



Students also learned to understand the difference between facts and judgments. They recognized that only facts are the subject of verification, while personal judgments are often used to influence the readers's emotional and volitional spheres.

At the third stage, the students themselves created news employing the computer game called the "Manipulator" [42]. The purpose of the game is to identify the most advantageous mechanisms for creating junk and manipulative news widely used by unscrupulous journalists. In addition, while playing, the students determined which lexical and graphic tools can be used to influence our emotional sphere and the way such news can manipulate individuals' and communities' behaviour.

At the fourth stage, I offered news from the Internet to train the students' skills of verifying the truth or falsity of provided information. In this lesson, students used online resources and personal gadgets. At this stage, I put into service some ideas and concepts of the MOOC DIY EMI course (by Divina Frau-Meigs). I changed the social roles between groups to create and analyse messages.

Content creators generate context, depending on the task. Analysts read the information, check its sources, confirm or deny it, justify their conclusions, and decide whether to disseminate such information online or not.

First, the students were the authors of the news, then they had to analyse the messages written by the other groups.

Students were divided into 4 groups. Each group chose three topics from the proposed list and prepared fake or true news. It was up to students to decide which news would be created as fake and which as the truth. After the news presentation, other groups had to determine its truth or falsity. They had to argue and prove their point of view after checking and comparing the facts.

The fifth and final lesson was devoted to the author's game "Why do I need ...?". The purpose of the game to show how different features of the item can be highlighted in negative or positive light with the aim of attracting buyers or vice versa (if you act as a competitive company). The game helps to identify the most advantageous mechanisms for creating junk and manipulative news widely used by unscrupulous journalists. In addition, while playing, the students determined which lexical and graphic tools can be used to influence our emotional sphere and the way such news can manipulate the behaviour of individuals and communities.

Students in groups created ads using data from online resources. One of the tasks was to make news about a new kind of medicine that helps people quit smoking. Students in groups 1 and 2 had to write a message that would stimulate the purchase of the medicine with the conditional brand name "smoky-nicht." Students of group 3 and 4 played the role of a rival company who needed to write a message aimed at reducing sales of this medicine.

The final questioning that was conducted to determine the level of media literacy showed that 63.4% of the respondents were able to give the correct answers. The correct answers were obtained in the majority of cases. (By the majority, I mean more than 50% of the correct answers).

After checking the hypothesis of differences between the levels of media literacy of students before and after the training, the following results were obtained: 63.4 % of students spotted fake news (it is and 42.2% more than before the training), and

79.6% of students used technical devices for fact checking (it is 73.9% more than before the training).

That hypothesis is accepted that the proportion of level of media literacy after the training is higher than it was before. Moreover, after the training the students recognized the dominant role of information technology for fact checking and used them in practice.

Thus, the obtained results demonstrate an increase in media literacy by a rate of 42.2%. Furthermore, 79.6% of the students answered that they planned to apply their new skills into practice. This result confirms our hypotheses about the effectiveness of information technology use in media literacy trainings (see Fig. 3).

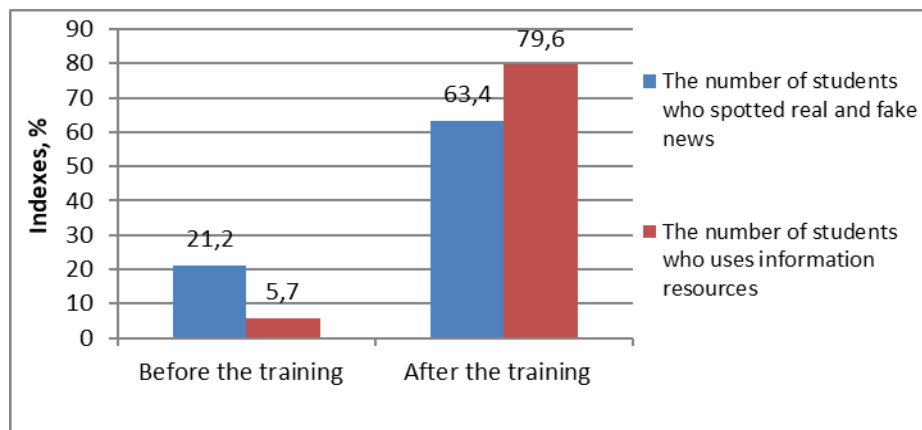


Fig. 3. The level of media literacy before and after the training.

#### 4 Discussion

The analysis of the obtained results manifests that personal experience and the use of Internet resources make it possible to better get to know the technology involved in creating user-generated content. Students discovered that media can manipulate them if they don't understand the techniques. Furthermore, media creators use judgments to impose their opinions and to create images and textual content based on a task description. Students saw that any textual or graphic material is a product of human activity, thus it can be used for diverse manipulative purposes. Acting as a content generator in different situations, a student will be able to perceive information more critically, understand the way junk news is created, and how such can be verified by available technical devices.

Students noticed that the texts addressing our emotions have the greatest impact on readers' consciousness. Human emotions provoke an instant reaction and create favourable conditions for the rapid spread of fake news. Students also concluded that any information product of which they might doubt the veracity should be a subject of verification, yet it requires skills of working with information technologies to verify its truthfulness.

Our training sessions showed that the use of advanced technologies is an effective way to develop easy-to-use skills. The course can be used in both online education and practical classes for developing critical thinking in the frame of media literacy education.

Up-to-date information and communication technologies can be sources of misinformation, misunderstandings, and conflicts in society. However, at the same time, information technologies make it possible to master the skills necessary for understanding the basics of media and information literacy.

I recommend implementing our training in other media literacy courses. However, it should be noted that the number of classes and academic hours may vary according to age and social group appropriateness. I worked with students whose future work is related to information security, so five class sessions were enough for them to develop the required skills. I consider that the number of classes and examples of messages should vary depending on the target audience. Audiences of media and information literacy courses should be aware that information technologies provide an opportunity to acquire the skills necessary to verify and analyse media messages.

## 5 Conclusions

The aim of the experiment was to justify empirically the theoretical assumption that the proposed approach was really effective. The results demonstrated that the usage of technical devices increase the level of media literacy and stimulate students apply their knowledge in their everyday practice.

Thus, my study confirmed the hypotheses put forward earlier, that the use of technical means increases the effectiveness of media and information literacy training. Moreover, knowledge and skills in this area increase the probability of applying the knowledge gained in everyday practice. The high probability of applying this knowledge in practice is explained by the availability of technical personal devices, like mobile phones, gadgets, laptops, etc.

I consider our course to be an important tool for increasing the effectiveness of media literacy trainings for any audience. Therefore, I recommend its introduction into the practice of media literacy courses.

It is noteworthy that practical assignments (examples of messages, creative challenges, and tasks) should be selected by each teacher, depending on the age and social group. In the future, I plan to develop guidelines for the use of information technologies for media literacy training.

## References

1. Information and Communication Technologies in Education. In: IITE UNESCO. Ed. D.Badarcha. Moscow (2013). <http://www.iite.unesco.org> (in Russian).
2. Opposition to Russian Propaganda and Media Literacy: Results of All-Ukrainian Opinion Poll. Analytical Report. In: Detector Media. Kyiv (2018).

- [https://detector.media/doc/images/news/archive/2016/136017/DM\\_KMIS\\_engl\\_\\_WEB-2.pdf](https://detector.media/doc/images/news/archive/2016/136017/DM_KMIS_engl__WEB-2.pdf), last accessed 2019/03/14.
3. Media and Information Literacy. In: UNESCO Institute for Information Technologies in Education. <https://iite.unesco.org/ru/mig/>, last accessed 2019/03/14.
  4. Manipulating Social Media to Undermine Democracy. In: Freedom House (2017). <https://freedomhouse.org/report/freedom-net/freedom-net-2017>, last accessed 2019/03/14.
  5. Media literacy: do people really understand how to make the most of blogs, search engines or interactive TV? In: The Press Release of European Commission IP/07/1970. Brussels (2007). [http://europa.eu/rapid/press-release\\_IP-07-1970\\_en.htm](http://europa.eu/rapid/press-release_IP-07-1970_en.htm), last accessed 2019/03/14.
  6. Lau, J.: A guidelines on information literacy for lifelong learning. In: IFLA. México (2006). <https://www.ifla.org/files/assets/information-literacy/publications/ifla-guidelines-en.pdf>, last accessed 2019/03/14.
  7. Dorr, A.: Media Literacy. In: International Encyclopedia of the Social & Behavioral Sciences. 2001. Vol. 14, pp.9494-9495. Oxford, United Kingdom (2001).
  8. Masterman, L.: New Paradigms and Directions. *Telemidium, Journal of Media Literacy*, vol. 46, № 1, (2000)
  9. Paul, R., Elder, L.: The Miniature Guide to Critical Thinking Concepts & Tools (7th edition). In: Foundation for Critical Thinking (2016).
  10. Parry, B., Potter, J., Bazalgette, C.: Creative, Cultural and Critical: Media Literacy. Theory in the Primary Classroom. In: Inter-disciplinary.net. 7th Global Conference, Creative Engagements: Thinking with Children, 4-6 July 2011, Oxford, United Kingdom (2011).
  11. Tyner, K.: Trendspotting in Media Education. *Toward Media Literacy: Contemporary Voices*. In: The Journal of Media Literacy, pp. 35-41. Madison, WI: National Telemedia Council (2015).
  12. Worsnop, C.: Screening Images: Ideas for Media Education (Second Edition). In: Mississauga, Wright Communication (1999).
  13. Divina, Frau-Meigs: Developing a critical mind against fake news. In: The UNESCO courier, June-September (2017). <http://unesdoc.unesco.org/images/0025/002523/252318e.pdf>, last accessed 2019/03/14.
  14. Buckingham, D.: Defining digital literacy: What do young people need to know about digital media? In: *Nordic Journal of Digital Literacy*, 4, pp.21-34 (2015).
  15. Hart, A.: Media Education in the Global Village. In: *Teaching the Media. International Perspectives*. Mahwah (USA.), London (UK) (1998).
  16. Krylova-Grek Y.: Peculiarities of information science based on the pilot course “Psycholinguistic basics of media literacy”. In: *Challenges and the Barriers in Open Education. 13th conference reader*. June 25-26, Prague (2018).
  17. Giles, D.: Media psychology. In: *Media Psychology*. January. (2003). doi: 10.4324/9781410607263.
  18. Rutledge, P. B.: Arguing for Media Psychology as a Distinct Field. In: *Oxford Handbook of Media Psychology*, pp. 43-58. New York: Oxford University Press (2013).
  19. Ashrafi-rizi, H., Khorasgani, Z.Gh., Zarmehr, F., Kazempour, Z.: A survey on rate of media literacy among Isfahan University of Medical Sciences’ students using Iranian media literacy questionnaire. In: *Journal of education and health promotion*, vol. 3, p. 49. (2014). doi:10.4103/2277-9531.131939.
  20. Naidenova, L.: *Mediapsychology: osnovy refleksivnogo podhoda* (In Ukraine). National Academy of Pedagogical Science, The Institute of social and political science. Kirovograd, Imex-LTD (2013).
  21. International Research & Exchanges Board (IREX). *Project on medialiteracy “Ne vir-perevir”*(2019).

22. [https://www.facebook.com/groups/277908126467127/?multi\\_permalinks=282801362644470&notif\\_id=1550851682941932&notif\\_t=group\\_highlights](https://www.facebook.com/groups/277908126467127/?multi_permalinks=282801362644470&notif_id=1550851682941932&notif_t=group_highlights), last accessed 2019/03/14.
23. Project «Media literacy program for citizens». <http://www.aup.com.ua/en/project-medialiteracy-program-for-citizens/>, last accessed 2019/03/14.
24. Wan, Ng.: *Mobile Technologies and Handheld Devices for Ubiquitous Learning: Research and Pedagogy*. IGI Global (2010). doi: 10.4018/978-1-61692-849-0.
25. Wan, Ng, W., Nicholas, H., Loke, S., & Torabi, T.: Designing effective pedagogical systems for teaching and learning with mobile and ubiquitous devices in Goh, T. T. (Ed). *Multiplatform E-Learning Systems and Technologies: Mobile Devices for Ubiquitous ICT-Based Education*. (pp. 42 – 56). Hershey, PA: IGI Global Publishing (2010).
26. Herrington, J., Ostashewski, N., Reid, D., Flintoff, K.: Mobile technologies in teacher education : Preparing pre-service teachers and teacher educators for mobile learning. In: *Effective teacher education: Partnerships, reflective practice and the place of technology*, Sense Publishers (2014).
27. Traxler, J.: Learning in a mobile age. In: *International Journal of Mobile and Blended Learning* 1(1) (2009). doi:10.4018/JMBL.2009010101.
28. Keogh, Katrina. A., Mhurchú J. Ní: Changing policy and an innovative response: Teaching, learning and assessing Irish using mobile phones. In: *Many voices: Language Policy and Practice in Europe* (2009).
29. Kolb, L.: *Toys to tools: Connecting student mobile phones to education*. Moorabbin, Vic.: Australia: Hawker Brownlow Education (2009).
30. Keengwe, J.: *Pedagogical Applications and Social Effects of Mobile Technology Integration*. In: IGI Global (2013). doi:10.4018/978-1-4666-2985-1.
31. Kitchenham, A.: *Models for Interdisciplinary Mobile Learning: Delivering Information to Students* (2011). doi: 10.4018/978-1-60960-511-7.
32. Parsons, D.: *Mobile and Blended Learning Innovations for Improved Learning Outcomes* (2016). doi:10.4018/978-1-5225-0359-0.
33. Parsons, D.: *Combining E-Learning and M-Learning: New Applications of Blended Educational Resources* (2011). doi:10.4018/978-1-60960-481-3.
34. Chao, Lee: *Open Source Mobile Learning: Mobile Linux Applications*. In: IGI Global (2011). doi:10.4018/978-1-60960-613-8.
35. *Recommendations Addressed to the United Nations Educational Scientific and Cultural Organization UNESCO*. In: *Education for the Media and the Digital Age*. Vienna. Reprint in: *Outlooks on Children and Media*. Goteborg, UNESCO & NORDICOM, (2001).
36. Bykov, V.Iu.: Mobile space and mobile-oriented Internet environment: features of model presentation and educational application (In Ukraine). In: *Information technology in education* (17). 09-37. (2013)
37. Who stole my pictures? <https://addons.mozilla.org/de/firefox/addon/who-stole-my-pictures/>, last accessed 2019/03/14.
38. FactCheck <https://www.factcheck.org/>, last accessed 2019/03/14.
39. VoxUkraine. <https://voxukraine.org/uk/voxcheck/>, last accessed 2019/03/14.
40. Foto Forensics. <http://fotoforensics.com/>, last accessed 2019/03/14.
41. Findexif.com. <http://www.findexif.com/>, last accessed 2019/03/14.
42. Pipl.com. <https://pipl.com/>, last accessed 2019/03/14.
43. Text.Org. “Manipulator” on-line game. [http://texty.org.ua/d/manipulator-game/?fbclid=IwAR28Psk6Jz6ZvfHjVIO6wa2JGkFXPpSnRuZnj6umky95GC40\\_-0DYdMDKnc](http://texty.org.ua/d/manipulator-game/?fbclid=IwAR28Psk6Jz6ZvfHjVIO6wa2JGkFXPpSnRuZnj6umky95GC40_-0DYdMDKnc), last accessed 2019/03/14

## Information-Analytical Support for the Processes of Formation of "Smart Sociopolis" of Truskavets

Mykola Odrekhivskyy<sup>1</sup>, Nataliia Kunanets<sup>2</sup>, Volodymyr Pasichnyk<sup>2</sup>, Antonii Rzheuskyi<sup>2</sup>, Danylo Tabachishin<sup>2</sup>

<sup>1</sup>Department of Management and International Business, Lviv Polytechnic National University, Lviv, Ukraine

<sup>2</sup>Information Systems and Networks Department, Lviv Polytechnic National University, Lviv, Ukraine

odr2002@ukr.net, nek.lviv@gmail.com, vpasichnyk@gmail.com  
antonii.v.rzheuskyi@lpnu.ua, tabachyshyn.danylo@gmail.com

**Abstract.** The projects of the creation of "Smart sociopolis" contribute to the transformation of territorial structures into the open market for investments and provides for the use of modern technologies for the reorganization of the existing fundamentals of ownership into a more flexible, capable of adapting to any changes in the external sector. The urgent issues of informational and analytical support of the processes of formation of recreational innovative structures on the example of the Truskavets sociopolis are analyzed. The socio-economic background and methodological aspects of construction of recreational innovative structures, approaches to their management with the purpose of transformation into "smart sociopolis" are highlighted. The methodological principles of organization and integration of sociopolises to modern economic conditions are suggested. The mathematical models of estimation and forecasting of states, stability and efficiency of sociopolis development are proposed. The effectiveness of innovative and technological processes for the formation of the Truskavets sociopolis mainly depends on the states of their organizational management structures. Innovative approaches to intellectualization and optimization of the management of sanatorial technologies of the Truskavets sociopolis are proposed in order to transform it into a "smart sociopolis" as an integrated system capable of efficient functioning, to provide for a sustainable development and to win the competition among analogous structures of Ukraine and abroad. The model of the structure of sociopolis with taking into account its potential possibilities is suggested. The modern tools of organizational management of the Truskavets sociopolis based on modern information technologies and providing effective processes for the development of the Truskavets sociopolis, providing it with adaptive ability, resistance to environmental conditions are suggested.

**Keywords:** information-analytical support, smart sociopolis, recreational innovative structures, economic conditions.

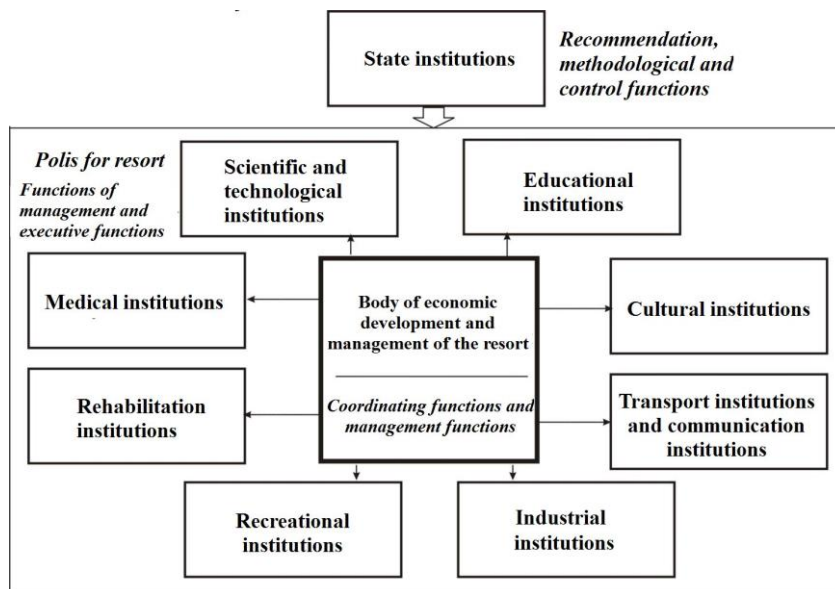
## **1 Introduction**

Local self-governing is of especial importance in the system of the territorial structure of the state. In many countries the structure of local self-governing is one of the forms of formation of local authorities. The structures of local self-governing are basic elements of the territorial structure of the country. The bearer of local self-governing and, consequently, the subject of administrative activity is the territorial community, which is interpreted as a set of citizens of Ukraine who live together in an urban or rural settlements, have collective interests defined by law and legal status. Unlike the usual territorial unit, the settlement, which has the status of a territorial community, is endowed with extended rights.

## **2 The Presentation of the Main Material**

In modern society, technology to create modern sociopolises has been spread. One of such sociopolis is Truskavets, around which are located resort towns. Sociopolis is reorganized from the special (free) economic zone of the tourist-recreational type "Polis for resort of Truskavets", which is active since January 1, 2000, and has been established for a period of 20 years in administrative-territorial boundaries of the city of Truskavets in Lviv region [1]

For further development of Truskavets and other resort complexes, it was expedient to use modern scientific technologies for the development, treatment and rehabilitation, service and necessary for the effective development of the resort of production, transforming the sociopolis into a high-tech settlement. Structures of this type are called "Smart Sociopolis". The projects of the creation of "Smart Societies" contribute to the transformation of territorial structures into open areas for investment and provide the introduction of modern technologies. Transformation of Truskavets to "Smart Sociopolis" has high chances to enter the World network of health care institutions and correspond to the status of health resorts of international level. This led to the need to reorganize the existing fundamentals of ownership into a more flexible, capable of adapting to any changes in the external sector. It was precisely this form that was supposed to respond to the innovative structure of the system of social policy, so that it could become the only organism that can efficiently function, provide a sustainable development and to compete among similar institutions of the country and abroad. It is this model of the structure of sociopolis was proposed after the analysis of its potential. The general structure of sociopolis is presented in Fig. 1.



**Fig. 1.** The general structure of the sociopolis

The main elements of the Truskavets sociopolis are business entities, branches, and other units located on its territory. That is, sociopolis is a resort - a set of cities that function as the only "smart" economic complex, the development of which is based on the development, realization and implementation in the health-improving process of the latest information technologies, innovative approaches to the development of recreational, health and rehabilitation processes, ecological research, services, support industries and management. The main elements of the sociopolis Truskavets are business entities, branches, and other units located on its territory. That is, sociopolis is a resort - a set of cities that function as the only "smart" economic complex, the development of which is based on the development, realization and implementation in the health-improving process of the latest information technologies, innovative approaches to the development of recreational, health and rehabilitation processes, ecological research, services, support industries and management. An important aspect of creating the smart Truskavets sociopolis is the introduction of new computer technologies that provide highly qualified treatment based on the use of modern medical equipment.

Analysis of the experience of the organization of analogous structures in the foreign countries, we came to the conclusion that the organization of a reasonable sociopolis Truskavets will have such prospects [2, 3]:  
For Ukraine:



- formation of a model for the development of sociopolys and recreational areas, the possibility of the development of new methods and principles of their organizational management;
- the possibility of implementation of a new form of rehabilitation of the population of Ukraine in the context of reorganization of the health care system;
- development and distribution of new technologies in Ukraine: diagnostics, recreation, rehabilitation and treatment, services, landscaping and formation of resort architecture, biotechnology, preventive and restorative phytotherapy, waste management;
- development of methods of formation of the modern market of sanatorium-resort services, organization of effective and systematic rehabilitation of the population of Ukraine.

For Truskavets sociopolis and the region it is:

- -improvement on the basis of introduction of information technologies of the system of management of the sociopolis;
- increase of revenues to the budget of the sociopolis and creation of additional work places;
- increasing the level of environmental protection and rational use of natural resources;
- establishment of environmental monitoring and the possibility of correction of environmental conditions of the Truskavets sociopolis;
- increase in the level of medical, cultural and consumer services for the population and tourists;
- preservation and reproduction of natural flora, medicinal plants based on the achievements of medical botany;
- intensive development of landscape gardening, construction and architecture;
- development of technologies for utilization of waste;
- development of sewage treatment industry;
- improvement of the organizational structure of the trading network and service;
- development of communication and transport industry;
- setting up of the special conditions for the study of foreign languages and the maintenance of the population by means of the connection of the sociopolis of Truskavets to the international information media;
- keeping the objects of non-precision in a proper condition.

Taking into account the recreational resources available in Ukraine, the creation of a smart "Sociopolis Truskavets" contributes to the construction of regional and national recreational innovation systems. Such a structure may play the role of a basic organization in the Carpathian recreational innovation system [[4], [5] ].

There is a need to create similar structures in other recreational zones of Ukraine. They may be city resorts operating in these areas after their reorganization. In regions of Ukraine that do not belong to recreational zones, it is desirable to create recreational parks and recreational polises, the profile of which may be determined by

the natural resource potential and the probability of diseases of the inhabitants of these regions (Fig 2, 3).

Consequently, the recreational parks, recreational polises, recreational resorts, other recreational innovative enterprises and the interconnections among them can become a prospect of a national recreational innovation system as a new form of public health protection in Ukraine.

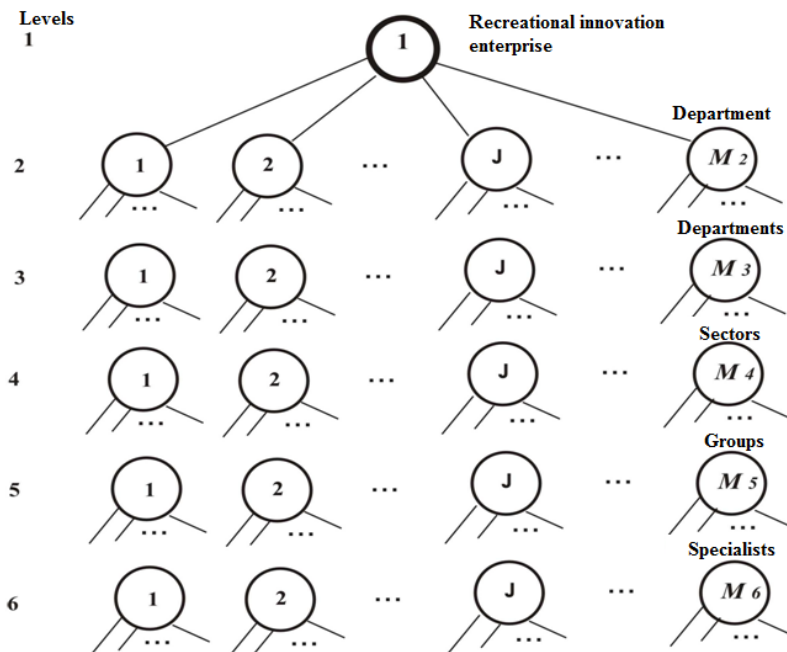
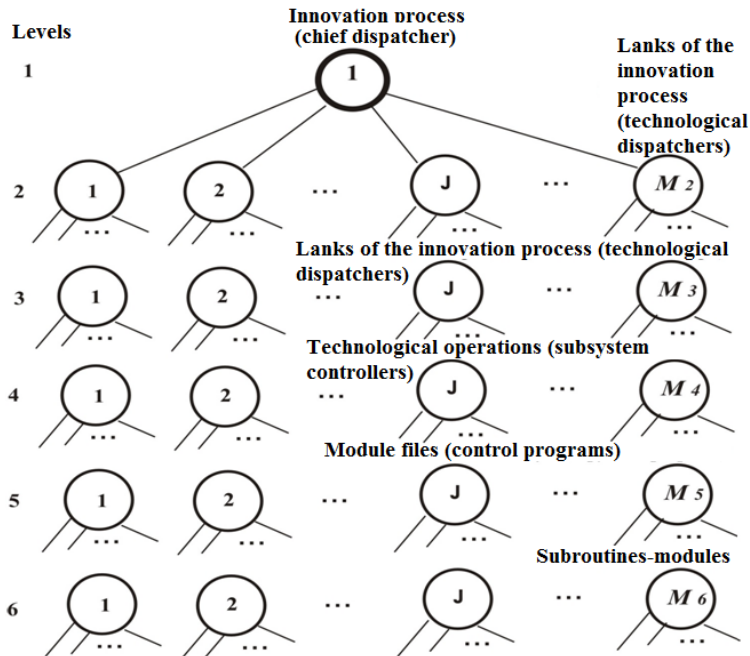


Fig. 2. Hierarchical structure of recreational innovation enterprise



**Fig. 3.** Hierarchical structure of the intellectual system management of recreational innovation process

To form an effective model of the smart Truskavets sociopolis, economic and mathematical methods are widely used in the study of the development processes of socio-economic systems and their structural units, which is one of the prerequisites for the use of these methods in our study of development. The study of prospects for the development of the Truskavets sociopolis, with the help of economic and mathematical methods, will facilitate the study of the plurality of factors that affect certain aspects of business entities of the Truskavets sociopolis, and hence the determination of possible additional reserves for improving the efficiency of its functioning. It is primarily about the production and solving new problems multivariate analysis, evaluation and forecasting of conditions of stability and effectiveness of the development of economic systems of the Truskavets sociopolis, the solution of which is impossible with the help of traditional methods.

The basis of the construction of mathematical models for estimating and forecasting the state of development of the Truskavets sociopolis, in order to make optimal managerial decisions on effective marketing-oriented development management, proposes to put the principle of hierarchy of complex systems, since socio-economic systems (which include the Truskavets sociopolis), complex technical systems (technological processes) and living systems of different levels of organization (cell, organs or living organisms, populations in general) belong to systems with a bug level hierarchical structure [ 6], [7]. This is conditioned by the fact that the functioning of the control systems of intellectuals , the Truskavets sociopolis

in general, as well as the human body are subordinated to a certain goal, the achievement of which can be regarded as the realization of the structural-functional state, which covers the elements of many levels of the hierarchy [8]. That is the general scheme of managerial action as well will provide is to achieve the goal, can be displayed in a hierarchically organized management system, which includes the following three levels.

The first, microlevel of control systems, manages local management responses, which are actually specific responses, for example, the body cells for changes in the environment, the operating elements of the Truskavets sociopolis, or the modules of the subprograms of intellectual technologies.

The second level, the meso-level, created by a set of elements (specialized control systems) of the micro level, which in a certain way interact, manages the internal environment of the human body, units of the Truskavets sociopolis or intellectual systems.

The third level, macrolevel, adjusts the control systems of the lower levels, introducing the corresponding changes to the specific reactions of the first, and the complex of their interactions in the second level.

That is, the control systems of the level of the organism, the Truskavets sociopolis and intellectual technologies, the specified structural hierarchy of living, social and technical objects, include several special control systems that ensure the flow of metabolic processes in the cells of the body, the fulfillment of its vital functions, the implementation of technological and managerial processes in the Truskavets sociopolis, ensuring their organizational and economic functions. Therefore, in order to study the dynamic and static characteristics of the states and stability of the Truskavets sociopolis development, the effectiveness of their technologies will dwell in more detail on obtaining formalized descriptions of hierarchical structures by constructing a hierarchical pattern of models. This pattern of models should become an instrument for studying the states and sustainability of the Truskavets sociopolis development.

Efficiency and innovation processes in the formation Truskavets sociopolis largely depend on the state of their organizational management structures. Therefore, the development of specific procedures for mathematical modeling of hierarchical structures is relevant and can be widely used for evaluation, analysis and forecasting of stability and development of the Truskavets sociopolis, effectiveness of their innovation and technological processes.

Thus, the study of the state of development of the Truskavets sociopolis is suggested to be based on the presentation of the Truskavets sociopolis in the form of such a hierarchy: from the Truskavets sociopolis (macrolevel) – subdivisions (meso level) – specialists (microlevel).

Effective work of intellectual systems of organizational management of the Truskavets sociopolis, management of innovative and technological processes, the Truskavets sociopolis will be provided with the flexibility and adaptability of their functional structure organized on a hierarchical principle as follows: technological level (level of innovation process and its parts, macro level), level of intellectual

systems and subsystems (meso level), the level of module files and modules (micro-level).

If you know the structure of the process of life and its recovery for the investigated object and whether its elements, in principle, you can define the set of all possible states and intensities of transitions from state to state. This makes it possible to build graphs transitions peaks which are possible states of an object and, as edges - transitions from state to state with particular intensity value transitions. For example, if the system is known to be in some state  $S_i$ , and in order to move it to the state  $S_j$ , it is necessary for me to leave a certain event, then from the state  $S_i$  to the state  $S_j$  there is an arrow indicating the intensity of the implementation of this event (Fig. 4).

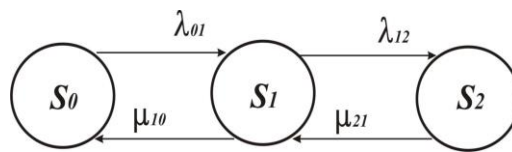


Fig. 4. Graph of Markov process

Note that when constructing such graphs, not all events (transitions) can be resolved. Restrictions on the count of transitions are explicitly contained in the verbal description of the principle of functioning and restoration of the investigated system. On the basis of the constructed conversion graph, it is easy to write a system of differential equations, whose solution will allow us to obtain probabilistic dynamics of states of the system.

It is also possible to present a probabilistic process by a matrix of transitions. The matrix of transitions for the graph depicted in Fig. 3, has the form:

$$P_{ij} = \begin{pmatrix} 0 & P_{01} & 0 \\ P_{10} & 0 & P_{12} \\ 0 & 0 & P_{21} \end{pmatrix}; \quad (1)$$

where  $p_{ij}$  is probability of transition from the  $i$ -th in  $j$ -th state;  $P_{ii}$  is probability of storage of the  $i$ -th state.

Let's dwell briefly on the method of determining the probabilities of states of the Markov process. Let an object whose state of dynamics is subject to investigation may be in states whose numbers are finite and equal to  $n$ . The states of the states  $S_0, S_1, \dots, S_{i-1}, \dots, S_n$  correspond to the indices  $0, 1, \dots, \text{and}, \dots, n$ . With  $both$   $i$ -th state to  $j$ -th state of the object moves with constant intensity  $\lambda_{ij}$ , and on the  $j$ -th state to  $and$  - state - with constant intensity  $\mu_{ji}$ .

To determine the probabilities of each of the states of the Markov process with any finite number of states of Kolmogorov proposed a system of differential equations [9, p. 336]. The application of the Kolmogorov differential equations for determining the probabilities of the states of the investigated object will be considered on an example of an object whose graph of states can be presented in the form depicted in Fig. 3.3, where the number of states of the object is equal to three.

The probability that the object on the time interval  $\Delta t$  with respect to time  $t$ , is in the state  $S_0$  is the product of the probability that an object at time  $t$  is in the zero state, the probability that it will pass on the interval  $\Delta t$  from the state  $S_0$  to the state  $S_j$ , plus the product of the probability that the object at the time  $t$  is in the state  $S_j$ , the probability that it will pass to the state  $S_0$  from the state  $S_j$  in time  $\Delta t$  [10]. This formula is written as follows:

$$P_0(t + \Delta t) = P_0(t) \cdot \{1 - [P_{01}(\Delta t)]\} + P_1(t) \cdot P_{10}(t). \quad (2)$$

Similarly written equations for the probability that the object on the time interval  $\Delta t$ , that is the time  $t$ , in a state  $S_1$  and  $S_2$ . The result is a system of equations:

$$\begin{aligned} P_0(t + \Delta t) &= P_0(t) \cdot (1 - P_{01}(\Delta t)) + P_1(t) \cdot P_{10}(t), \\ P_1(t + \Delta t) &= P_1(t) \cdot (1 - (P_{12}(\Delta t) + P_{10}(\Delta t))) + P_0(t) \cdot P_{01}(\Delta t) + P_2(t) \cdot P_{21}(t), \\ P_2(t + \Delta t) &= P_2(t) \cdot (1 - P_{21}(\Delta t)) + P_1(t) \cdot P_{12}(t). \end{aligned} \quad (3)$$

Probability of transition of object from state  $S_i$  to state  $S_j$  with intensity  $\lambda_{ij}$  is equal to:

$$P_{ij}(\Delta t) = 1 - e^{-\lambda_{ij} \cdot \Delta t} = 1 - (1 - \lambda_{ij} \cdot \Delta t) = \lambda_{ij} \cdot \Delta t \quad (4)$$

Probability of transition from state  $S_j$  to state  $S_i$  with intensity  $\mu_{ji}$  is equal to  $\mu_{ji} \cdot \Delta t$ . The probability of no transitions from the state of  $S_j$  in the state  $S_2$  and  $S_0$  is:

$$1 - (P_{12}(\Delta t) + P_{10}(\Delta t)) = 1 - (\lambda_{12} \cdot \Delta t + \mu_{10} \cdot \Delta t) \quad (5)$$

Substituting the expressions in (3), we obtain the following system of equations:

$$\begin{aligned} P_0(t + \Delta t) &= P_0(t) - P_0(t) \cdot \lambda_{01} \cdot \Delta t + P_1(t) \cdot \mu_{10} \cdot \Delta t, \\ P_1(t + \Delta t) &= P_1(t) - P_1(t) \cdot (\lambda_{12} + \mu_{10}) \cdot \Delta t + P_0(t) \cdot \lambda_{01} \cdot \Delta t - P_2(t) \cdot \mu_{21} \cdot \Delta t, \\ P_2(t + \Delta t) &= P_2(t) - P_2(t) \cdot \mu_{21} \cdot \Delta t + P_1(t) \cdot \lambda_{12} \cdot \Delta t. \end{aligned} \quad (6)$$

On the right-hand side of the equations of the system of equations (6) emotions were transferred to the left part of  $P_i(t)$ . Dividing the right and left sides of equations for  $\Delta t$  and considering that:

$$\begin{aligned} P_i(t + \Delta t) - P_i(t) &= \Delta P_i, \\ \Delta P_i / \Delta t &= dP_i / dt, \end{aligned} \quad (7)$$

the system of equations (6) can be reduced to a system of differential equations:

$$\begin{aligned} dP_0 / dt &= -\lambda_{01} \cdot P_0(t) + \mu_{10} \cdot P_1(t), \\ dP_1 / dt &= \lambda_{01} \cdot P_0(t) - (\lambda_{12} + \mu_{10}) \cdot P_1(t) + \mu_{21} \cdot P_2(t), \\ dP_2 / dt &= -\mu_{21} \cdot P_2(t) + \lambda_{12} \cdot P_1(t). \end{aligned} \quad (8)$$

We can also get the system of differential equations (8) directly in the form of a state graph if you use it so they rule [11, p. 123]: "For each of the possible states of the object a, an equation is written, the left part of which is  $dP_i / dt$ , and to the right are as many constituents as the arcs of the graph touches this state. If the arc of the graph is directed to this state, then a plus sign is placed before the equation of equation if the arrow is directed from this graph a -minus. Each of the components of

the equation and is equal to the product of the intensity of this transition state (or in this state) the probability state from which comes an arrow. "

If the study is Markov and stationary process, for which derivatives  $dP_i / dt$  can be taken to be zero (probability states do not change over time), the system of differential equations (8) goes with the system of algebraic equations:

$$\begin{aligned} -\lambda_{01} \cdot P_0(t) + \mu_{10} \cdot P_1(t) &= 0, \\ \lambda_{01} \cdot P_0(t) - (\lambda_{12} + \mu_{10}) \cdot P_1(t) + \mu_{21} \cdot P_2(t) &= 0, \\ -\mu_{21} \cdot P_2(t) + \lambda_{12} \cdot P_1(t) &= 0, \\ P_0 + P_1 + P_2 &= 1. \end{aligned} \quad (9)$$

The fourth equation for this system (for three unknowns) becomes necessary because the first three are reduced to two, and the number of unknown probabilities of states in this system of equations is equal to three. The solution of the system of algebraic equations (9) will look like:

$$\begin{aligned} P_0 &= 1 / [1 + \lambda_{01} / \mu_{10} + \lambda_{01} \cdot \lambda_{12} / (\mu_{21} + \lambda_{10})], \\ P_1 &= P_0 \cdot \lambda_{01} / \mu_{10}, \\ P_2 &= P_0 \cdot \lambda_{01} \cdot \lambda_{12} / \mu_{21} \cdot \mu_{10}. \end{aligned} \quad (10)$$

If the set of states studied objects and large, the system of equations (10) should be solved with the help of cybernetic technology.

The suggested methodology for modeling the state of development of Truskavets sociopolis has a scientific and practical interest, since it enables:

- to optimize innovative and technological processes;
- analyze, evaluate, predict states, stability and effectiveness of RIE development;
- to support the adoption of optimal managerial decisions.

Since the studied systems are considered complex, each of which acts in at least two functions - as an element of a more complex system and as a system consisting of elements, that is, simpler subsystems, which, in turn, are also systems consisting of elements, etc.

In order to appraise the proposed mathematical models for estimating and forecasting the state of development of the Truskavets sociopolis, we conducted a study of the state of development of the sanatorium and resort complex of Truskavets, which includes 23 sanatoriums and 8 boarding houses. Interest in these studies is due to the fact that the Truskavets sociopolis and its basic structures form a unified innovation structure in the region.

In this case, the states:

*S1 (UN)* - "unsatisfactory" state of development of the sanatorium and resort complex, that is, the state in which the main economic indicators of the complex (for example, the volume of services rendered) are lower than planned but not lower than the indicators of the previous year;

*S2 (S)* - "satisfactory" state of development of sanatorium and resort complex, that is, the state in which the basic economic indicators of the complex correspond to the level planned;

$S3 (G)$  – "good" the state of development of the sanatorium and resort complex, that is, the state in which the main economic indicators of the complex are higher than the planned;

$S4 (VG)$  – "very good" the state of development of sanatorium and resort complex, that is, the state at which the main economic indicators of the complex are significantly higher than planned.

Having conducted research on the development of the sanatorium and resort complex Truskavets in 2006 – 2008, we received the following indicators:

in the state of  $S1 (NZ)$  there were 6 sanatoriums;

in  $S2 (S)$  - 11 sanatoriums;

in  $S3 (G)$  - 10 sanatoriums;

in  $S4 (VG)$  - 4 sanatorium.

Thus, the probabilities of the states of the studied complex have the following initial values:

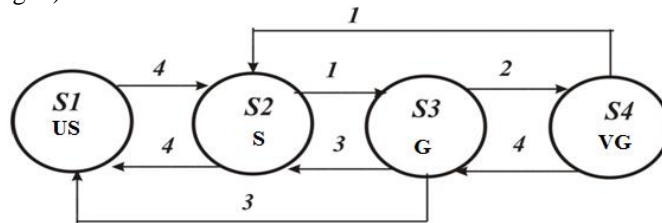
$$P_0 ( S 1 ) = 6/31 = 0.2;$$

$$P_0 ( S 2 ) = 11/31 = 0.35; \quad (3.23)$$

$$P_0 ( S 3 ) = 10/31 = 0.32;$$

$$P_0 ( S 4 ) = 4/31 = 0.13.$$

During the studied period, the developmental conditions of the studied health-improving complexes of Truskavets changed. The intensity of the transitions from state to state is depicted by the corresponding values above the arcs of the graph transitions (Fig. 5).



**Fig. 5.** Graph of states of development of the Truskavets sociopolis

To evaluate and predict the state of development of the Truskavets sociopolis with the help of the proposed mathematical apparatus in the previous section, we conducted a study of the dynamics of probabilities of the state of development of the sanatorium complex by calculating with the help of computer technology the system of Kolmogorov differential equations:

$$\begin{aligned} \frac{dP_{S_1}}{dt} &= -\lambda_{S_1, S_2} \cdot P_{S_1} + \lambda_{S_2, S_1} \cdot P_{S_2}, \\ \frac{dP_{S_2}}{dt} &= \lambda_{S_1, S_2} \cdot P_{S_1} - (\lambda_{S_2, S_1} + \lambda_{S_2, S_3}) \cdot P_{S_2} + \lambda_{S_3, S_2} \cdot P_{S_3}, \\ \frac{dP_{S_3}}{dt} &= \lambda_{S_2, S_3} \cdot P_{S_2} - (\lambda_{S_3, S_2} + \lambda_{S_3, S_4}) \cdot P_{S_3} + \lambda_{S_4, S_3} \cdot P_{S_4}, \\ \frac{dP_{S_4}}{dt} &= \lambda_{S_3, S_4} \cdot P_{S_3} - \lambda_{S_4, S_3} \cdot P_{S_4}. \end{aligned} \quad (11)$$



The research of the statics of the probabilities of the conditions of the development of the sanatorium complex is carried out by calculating with the help of computer technology the corresponding system of differential equations (11) of the system of algebraic equations:

$$\begin{aligned}
 & -\lambda_{S_1, S_2} \cdot P_{S_1} + \lambda_{S_2, S_1} \cdot P_{S_2} = 0, \\
 & \lambda_{S_1, S_2} \cdot P_{S_1} - (\lambda_{S_2, S_1} + \lambda_{S_2, S_3}) \cdot P_{S_2} + \lambda_{S_3, S_2} \cdot P_{S_3} = 0, \\
 & \lambda_{S_2, S_3} \cdot P_{S_2} - (\lambda_{S_3, S_2} + \lambda_{S_3, S_4}) \cdot P_{S_3} + \lambda_{S_4, S_3} \cdot P_{S_4} = 0, \\
 & \lambda_{S_3, S_4} \cdot P_{S_3} - \lambda_{S_4, S_3} \cdot P_{S_4} = 0.
 \end{aligned} \tag{12}$$

The system of differential equations (11) and the system of algebraic equations (12) describe the graph presented in Fig. 5.

In the study of the dynamic and static characteristics of the probabilities of the states of the studied complex on the main economic indicators, we can conclude that the most probable for the Truskavets sociopolis is the state in which the basic economic indicators of the complex are lower than the planned but not lower than the indicators of the previous one year.

That is, the complex develops and development can be considered:

- unsatisfactory - with a probability of 0.48;
- satisfactory - with a probability of 0.42;
- good - with a probability of 0.08;
- very good - with a probability of 0.02.

A more detailed analysis of the situation related to fixation of the state of Truskavets sociopolis is presented in the work [12]

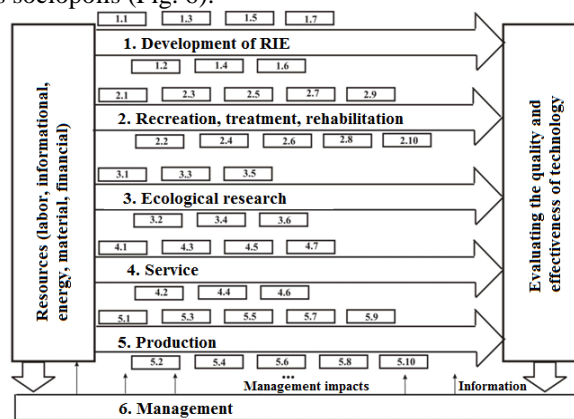
Truskavets sociopolis as a social system is open, it contains all the characteristics of cybernetic systems - controlled, consisting of a set of subsystems that act as mechanisms for the development and implementation of self-sustaining reactions.

That is, an effective control system should have a certain set of states that corresponds to a variety of states of the control object, and must have channels of information transmission that would allow timely reception of signals about the situation in the object of management and the external environment and the adoption of optimal solutions for the actual problems. From here it becomes clear the key role of the system of transmission and processing of information in modern management, the importance of intellectualization of managerial processes.

Opportunities of modern information technologies to store compactly, quickly to deduce, quickly and comprehensively to analyze, visually to display information, form and accumulate knowledge[13-15] and on this basis to form recommendations for adoption of optimum decisions, can be put in a basis of intellectualization of management of marketing-oriented technological changes and innovative processes in the recreational innovative enterprises as means of marketing-oriented management by the Truskavets sociopolis. The effectiveness of these approaches to intellectualization affect the quantitative and qualitative changes.

Quantitative changes related mainly to the use of information technology in routine operations in diagnostic experiments, which increase the level of standardization, accuracy and speed of obtaining diagnostic output and solutions, which is extremely necessary in psychosomatic examination and counseling of patients.

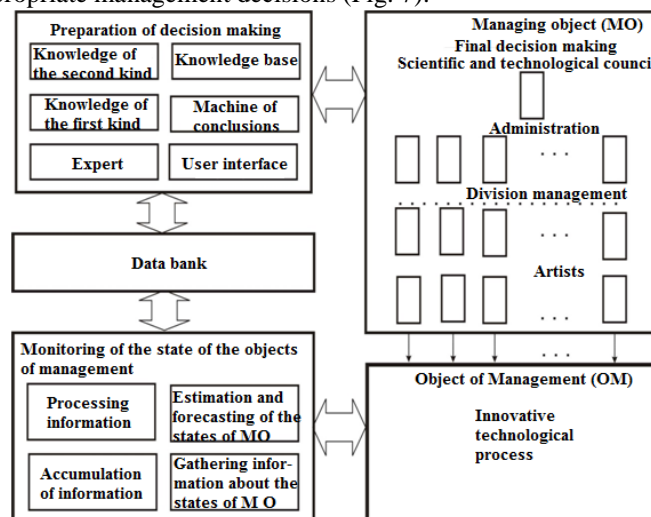
Qualitative changes are provided by the possibilities of modern information technologies to implement new types of diagnostic and other technological changes, based on the use of modern technologies of formation of databases and knowledge bases, pattern recognition algorithms, methods of artificial intelligence, which are based on the manipulation of knowledge in the areas caused by the technologies of formation of the Truskavets sociopolis (Fig. 6).



**Fig. 6.** Scheme of organization and management of technological changes and innovative processes

As the high efficiency of businesses most likely explained by the tendency of nih leaders to managerial innovations than the ability to improve processes, foreign theorists and practitioners of management came to the conclusion that the best form of organization of management companies should be considered flexible, adaptive control system, natural property which is continuous innovation, willingness to make any changes in the management, organization, technology, range, etc. System management of information and system requires rationalization of the structure of information flows, simplification of procedures for information exchange and document circulation, reduction of information overload, scientific approaches to the formation of effective analytical information, creation of firm databases and knowledge bases for the purpose of making optimal decisions. These problems with any intellectual system of management are constantly changing, since management companies, for their progressive development. It should be on innovative basis, that contain the means and measures for the implementation of modern innovation policy and operational management (a set of scientific, technical, production, management, marketing and other activities). The information that is necessary to ensure innovation policy should enable managers to navigate in technological issues, provide a basis for planning, identify priority problems, the formation of alternatives to overcome these problems, the choice of rules for decision-making. Information support of operational

management of enterprises should ensure implementation of planned plans, production of high-quality products, provision of efficient services, achievement of the planned level of economic indicators. That is, management as a system of control and regulation should provide the necessary information interaction between the enterprise and the external and internal environment. But for the effective operation of this service and the adoption of optimal solutions for managing the processes of development of the Truskavets sociopolis, it is recommended that they be implemented through the development and use of appropriate intellectual technology. This technology should be organized on such intellectual systems, based on information on the state of development of the Truskavets sociopolis, knowledge of experts aggregated in the knowledge base, automating the decision-making processes at the qualification levels of the Truskavets sociopolis employees, the states of the Truskavets sociopolis and the states development of Truskavets sociopolis in general, and worked out on this basis appropriate management decisions (Fig. 7).



**Fig. 7.** Intellectual system of marketing-oriented management of states of development of the Truskavets sociopolis

Thus, intellectualization technology marketing-oriented development management of the Truskavets sociopolis allows us to build a flexible, adaptive and stable management system of the Truskavets sociopolis, the natural property of which is constant innovation, readiness to make any changes in the market of healing goods and services, in management, organization, resources, technologies, goods and services.

### 3 Conclusions

Solving problems of organizing marketing-oriented management of the Truskavets sociopolis with the aim to adapt their organizational structures and business processes

to the dynamics of the environment should be based on software tools that make it possible to model organizational structure of the Truskavets sociopolis in general and to model that of a specific employee of Truskavets sociopolis in particular in his role, taking into account his knowledge, duties, intentions, and etc.

Creation of tools of organizational management of the Truskavets sociopolis using the achievements of informational technology, which primarily include intellectual systems and knowledge management system, helps to make diagnosis and prediction of conditions of stability and effectiveness of the Truskavets sociopolis, to provide the Truskavets sociopolis appropriate adaptive ability, resistance against environmental conditions, intensification of their development, development and introduction of new science-intensive technologies of recreation, treatment and rehabilitation, environmental research.

The basis of the tools necessary for creation and operation of control systems of the Truskavets sociopolis may contain integrated object-oriented and distributed databases and knowledge bases, hybrid expert systems, decision making support systems, integrated neural systems, etc. Decision making support systems allow us to model and automate decision making, simulate and automate organizational management of the Truskavets sociopolis. Distributed (decentralized) artificial intellect, integrated automated management systems and multiagent systems constitute the most suitable class of models for organizational marketing-oriented management for the Truskavets sociopolis.

Truskavets sociopolis is one of the most significant at the state level of Ukrainian tourist-balneological complexes. Its development and analytical processing of information concerning perspective directions of improvement is general-methodological and can be used as a platform for other resort, recreational and health sociopolises.

## References

1. Law of Ukraine "On special economic zone of tourist-recreational type" Kurortopolis Truskavets. Bulletin of Verkhovna Rada, 18, 139--144 (1999).
2. Odrekhivsky, M.: Valeological Innovation Centers: Economic Problems of Creation and Functioning (1997).
3. Gela, A., Malitsky, B., Odrekhivsky, M.: Truskavets - way to resort polis. New approaches to the organization and conduct of treatment, rehabilitation and recreation in the conditions of the resort: materials of the international scientific-practical conference. Truskavets, 10--16 (1995).
4. Odrekhivsky, M., Odrekhivska, O.: Innovative system of regional agglomeration Drohobychyna. Regional economics, 2, 228--238 (2008).
5. Odrekhivsky, M.: Carpathian valeological innovation system. Borderlands. Poland-Ukraine Scientific Yearbook, pp. 410--421 (2007).
6. Eshby, U.: Construction of the brain (1962).
7. Gouldner, A.: Partterns of industrial bureaucracy (1955).
8. Mesarovich, M.: Theory of Hierarchical Multilevel Systems (1973).
9. Kolmogorov, A.: Introduction to Probability Theory (1982).
10. Gnedenko, B.: Theory of reliability and mass service (1969).

11. Golinkevich, T.: Applied theory of reliability (1967).
12. Odrekhiivsky, M.: Marketing - oriented management of recreational innovative enterprises: the abstract of doctoral thesis on economics. Donetsk (2010).
13. Kunanets, N., Lukasz, W., Pasichnyk, V., Duda, O., Matsiuk, O., Falat, P.: Cloud computing technologies in “smart city” projects. In: 9th International conference on Intelligent Data Acquisition and Advanced Computing Systems: Technology and Applications (IDAACS), pp. 339--342. Romania, (2017).
14. Rzhеuskyi, A., Kunanets, N., Kut, V.: The analysis of the United States of America universities library information services with benchmarking and pairwise comparisons methods. In: 12th International Scientific and Technical Conference on Computer Sciences and Information Technologies (CSIT), vol. 1, 417--420 (2017).
15. Lypak, H., Rzhеuskyi, A., Kunanets, N., Pasichnyk V.: Formation of a consolidated information resource by means of cloud technologies. In: 2018 International Scientific-Practical Conference on Problems of Infocommunications Science and Technology, PIC S and T, Kharkiv, 157-160 (2018).

# The Main Aspects of the Introduction of ERP-Systems at the Machine-Building Enterprises

Irina Nyzhnyk<sup>1</sup>, Viktor Lysak<sup>1</sup>

<sup>1</sup>Khmelnytskyi National University, 11, Instytutska st., Khmelnytskyi, 29000, Ukraine  
nyzhnyk@khnu.km.ua, devstring@gmail.com

**Abstract.** Research goals and objectives: to carry out the analysis of the market of ERP-systems and to make scientific and practical recommendations for their choice for successful introduction at domestic machine-building enterprises.

*Subject of research:* design, implementation and use of ERP-systems at the machine-building enterprises of Ukraine.

*Research methods:* statistical, systematic and comparative analysis, modular design, analytical and expert methods.

*Results of the research:* The advantages of implementing ERP-systems at the machine-building enterprises have been evaluated, the most significant impact on individual indicators of enterprises has been determined and the advantages and disadvantages of automation of business processes at machine-building enterprises, depending on their separate types, are described. Examples of integration of subsystems on the basis of information flows and interaction of automated systems with external entities are given. It is proved that the success of the implementation of ERP-systems depends on the correct choice of the system class, the type of production, set priorities for the automation of business functions, taking into account the factors of criticality, readiness, speed and value. As a result, the maximum effect from the implementation of the ERP system potentially depends on: the completeness of its compliance with national legislation, the user interface's convenience and clarity, the ability to adapt to the industry-specific features and the specifics of the operation of a particular enterprise, the possibilities of integration into the system of external and internal modules, etc. It is important to involve the consulting companies, industry specialists and employees of the enterprise in the process of implementation.

**Keywords:** Enterprise Resource Planning (ERP), Enterprise Resource & Relationship Processing (ERP II), criteria for selecting, designing and implementation.

## 1 Introduction

Currently, the Ukrainian market has a large selection of high-class systems for automation of enterprises' functioning. The worldwide leaders in this field, represented in Ukraine, are products of SAP, Baan, Oracle and Microsoft companies. They are correctly localized and implemented, or are successfully implemented at the Ukrainian

enterprises. The products of such Ukrainian companies as "Information Technologies", Sirius System, IFS Ukraine and others are also common [8, 9, 12, 19]. And here, the main thing is not the creation of a large number of interesting information systems from the point of view of their developer. Design of ERP-systems should be aimed at the consumer, to offer managers and marketers more opportunities for understanding the views of consumers, to respond to their needs.

The current global trend towards building integrated enterprise management automation systems is the creation of the Enterprise Application Suite (EAS). This approach allows the most efficient use of the capabilities of accounting systems (ERP-systems, systems of financial and economic management, accounting programs) and OLAP-systems (planning and budgeting, knowledge management systems, data warehouses) and others.

However, most Ukrainian enterprises have different automated enterprise management systems that have been introduced long ago, they are inefficient and do not fully meet modern business management concepts and therefore can be classified by software capabilities. Among these systems are the following [9, 12, 19]: Material Requirements Planning System (MRP), Manufacturing Resource Planning System (MRP II), Manufacturing Execution System (MES), Customer Demand Planning System (CDP), Customer Relationship Management System (CRM).

Current demands for the operation of such systems require the use of advanced tools, a strong technological base, mobility, accessibility, reasonable price for the acquisition and service, taking into account relevant national standards [11, 15].

**The aim of the article** is to describe scientific and methodological foundations and practical recommendations on key selection criteria for the modern ERP-systems of a machine-building enterprise.

## 2 The Main Requirements for Modern ERP Systems

The analysis shows that for the Ukrainian enterprises the most relevant concepts of enterprise management systems are MRPII and ERP, which actually became world standards. They represent a set of general rules set out in 1980-1990 years [7]. Taking into consideration the fact, that ERP-systems are focused on fulfilling more tasks than MRPII, which focuses on managing production resources, in the article we focus on ERP, in particular, their modern version - ERP II.

It is difficult to calculate exactly what the ERP-system gives to the company, taking into account the diversity of systems, different conditions of enterprises before introduction, and the complexity and uniqueness of each project. An expert survey of specialists of machine-building enterprises of Khmelnytskyi region was conducted by us at the beginning of 2019. We asked about the effectiveness of the ERP-systems, introduced by them and the results of the survey showed positive results (Table 1).

Since the authors did not aim at assessing the effectiveness of embedded IT technology ERP-systems, then the calculation of the values of changes in table indicators did not apply common methods such as Return on Investment (ROI), Total Cost Ownership (TCO), Cost-Benefits Analysis (CBA) etc. Instead, the comparison of the

values of the indicators of economic characteristics before the implementation of the ERP-system and after the startup of the system at the enterprises was made. The assessment of qualitative and quantitative indicators was carried out on the basis of the points put forward in the questionnaires by experts of the enterprises, and also on the basis of statistical data of their financial reports.

**Table 1.** Estimated advantages after the introduction of ERP<sup>1</sup>

Indicator	Growth rate
Reducing the timing for closing the accounting period	95%
Improving general culture of management, reducing paper workflow, using the optimal scheme of business processes	90%
Increasing the number of deliveries right in time	80%
Reducing transport and procurement costs	60%
Improved after-sales	60%
Reducing delays in the shipment of finished products	45%
Increase in the turnover of the enterprise funds	35%
Reduced manufacturing defects	35%
Reducing business costs	35%
Reducing costs for administrative staff	30%
Improving the accuracy of cost accounting	30%
Reduced working capital requirements by improving the speed and quality of work	30%
Improvement of capital assets utilization	30%
Labor productivity growth	27%
Reduced warehouse space	25%
Reducing the time for the sale of goods	25%
Reduction of reserve stocks in warehouses, use of advanced methods of their planning and control	20%

As a result, as shown in table 1, the introduction of ERP systems in machine-building enterprises has had the most positive effect on the deadlines for closing the accounting period, the general culture of management, the use of optimal business process schemes, delivery in the exact terms, transport and procurement costs, after-sales service. For such a conclusion we have taken only those indicators, the growth rate of which exceeds 60%.

According to the statistical portal Statista, the entire world market of large and medium ERP was income from the sale of software \$ 82.1 billion in 2015 and the results of 2016 rose to \$ 82.3 billion [8]. The main problem when choosing the ERP modules and its implementation is the task of creating a unified system that meets the needs of employees at all departments [12, 13].

Modern enterprise management system that meets the ERP concept should have the following modules: Supply Chain Management (SCM), Advanced Planning and Scheduling (APS), Sales Force Automation (SFA), Stand Alone Configuration Engine

<sup>1</sup> Created by the authors based on the results of the expert survey of 28 machine-building enterprises of Khmelnytskyi region.



(SCE), Finite Resource Planning (FRP), Business Intelligence (BI), Online Analytic Processing (OLAP), E-Commerce (EC), Product Data Management (PDM) [6, 12].

Recently, one can observe the trend of intensive management technologies development aimed at improving the interaction with external entities: customers, suppliers, partners and others. These information systems are based on the management of a full cycle of production: from designing according to customer requirements to guarantee and service. These technologies in modern terms are: Customer Synchronized Resource Planning (CSR), Supply Chain Management (SCM), Customer Relationship Management (CRM).

### 3 ERP Selection Based on the Type of Production and Scale of Automation

In order to consider all the needs of a machine-building enterprise, the choice of ERP must begin with the analysis of production and, depending on its characteristics, focus on different management concepts and automated information systems. In the evaluation of existing trends in production planning, it can be noted that the individual production is the most difficult, which requires constant technological change, recruitment and changes in work processes and therefore, the use of ERP in this case is inappropriate. Here it is better to apply PERT (Program/Project Evaluation and Review Technique) methods and network planning methods, especially for analyzing the time for each individual task and minimizing the time spent on the whole project (Fig. 1).

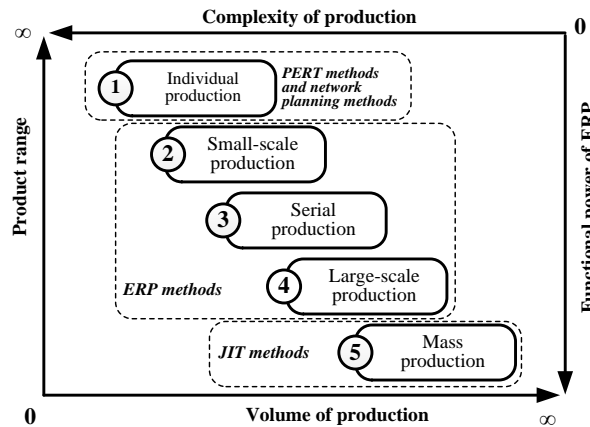


Fig. 1. Application of planning methods for different types of production depending on the volumes of production and its assortment<sup>2</sup>

The three following types are different versions of serial production, in which, when the seriality increases, the versatility of the equipment decreases and the spe-

<sup>2</sup> Suggested by the authors

cialization of workers shrinks, consequently, the number of types of finished products decreases, and the volume of output increases. The fifth type is characterized by mass production, the availability of specialized equipment, conveyors, technological complexes, the minimum number of types of products with maximum output volumes.

Research has shown that the use of modern flexible and powerful algorithms for the distribution of production processes has led to the development of Advanced Planning and Scheduling (APS). Therefore, the enterprises of the second, third and fourth types of production need to apply the concept of ERP, and for the fifth type - JIT-methods (Just-In-Time), because ERP-techniques for such production are too powerful. The scale of automation introduction at the machine-building enterprises of Khmelnytsky region can be divided into partial automation, by individual areas, by the chosen sphere of activity and full automation (Table 2).

**Table 2.** Features of automation of business processes at the enterprise<sup>3</sup>

Type of automation	Goal	Advantages and Disadvantages
Partial	Automation of certain local business processes	<i>Advantages:</i> individual subsystems are much cheaper than a complete solution. <i>Disadvantages:</i> lack of strategy; task locality; probability of getting pieces of unfinished infrastructure; additional costs due to functions duplication and servicing of unfinished modules; inefficiency of investment.
By individual areas	Automation of individual production areas or administrative units on functional grounds.	<i>Advantages:</i> automation systems in certain areas provide significant economic benefit; saving investment resources. <i>Disadvantages:</i> automation is carried out strictly under a certain type of manufacturing and its standards; frequent viewing of strategic and operational plans of automation
By sphere of activity areas	Automation of the chosen sphere of activity.	<i>Advantages:</i> implementing ERP & MRP II before full automation; all subdivisions of the chosen sphere of activity are involved; emerging information and communication structure of the company; a re-engineering of business processes and creating a business model. <i>Disadvantages:</i> requires frequent review of strategic and operational plans of automation; requires significant investments in hardware, software, hiring developers.
Full	Creation of an integrated enterprise management system.	<i>Advantages:</i> full integration of all modules and control units, procedures, functions and operations to a single system based on database; integration of the mathematical software on the basis of models and methods for providing planning and forecasting. <i>Disadvantages:</i> the need for adjustment of the strategic plan to reflect changes in the market; additional costs for service support and maintenance of hardware, software, hiring developers.

We have proved that in today's competitive processes ERP application helps optimize operations, reduces errors, improves forecasting and planning, and aims to significantly reduce costs and improve production processes. However, analyzing the advantages and disadvantages of automating business processes at an enterprise, it

<sup>3</sup> Systematized according to the advantages and disadvantages based on our own research

must be emphasized that everything depends on the needs and financial capabilities of each particular enterprise.

#### **4 ERP-Systems Selection Based on Their Capabilities**

Since the beginning of the 21st century, new functional capabilities of the ERP system have begun to evolve in the world, which went beyond the traditional features of automation and optimization of business processes of the ERP methodology. The traditional concept of ERP envisaged primarily work with internal enterprise resources, resource planning, careful inventory management and insurance of transparency of manufacturing processes. The functional of modern systems has been supplemented by modules such as SCM and CRM, responsible for optimizing external communications of the enterprise. There was a separation of concepts: the traditional ERP management was called back-office, and external applications that appear in the system - front-office. Thus, a new standard has appeared - ERP II (Enterprise Resource and Relationship Processing) [3].

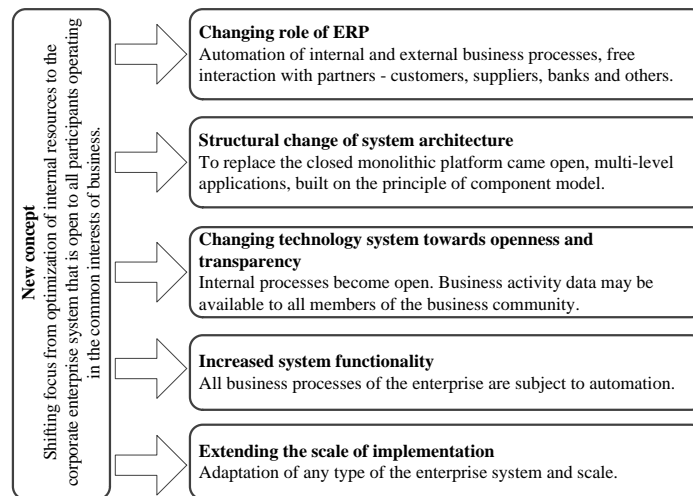
Our analysis confirms that new ERP really provides comprehensive management of key business processes, often in real time. Typically, these systems are represented by a set of integrated applications that the enterprise can use to collect, store, manage and view data about many types of their own activities. These systems monitor business resources (cash, raw materials, manufacturing facilities and the status of business liabilities (demand for products and materials) [2].

The analysis showed that the new ERP was complemented by the following modules [1, 6, 13, 19]:

- Supplier Relationship Management (SRM), which is designed to improve management, optimize purchasing power, improve customer service by selecting and properly working with suppliers, establishing and improving business processes with further analysis of results.
- Product Lifecycle Management (PLM), which helps in planning and optimizing production capacity and material resources.
- Supply Chain Management (SCM), which allows controlling processes in the warehouse and quickly respond to changes in supply and demand.
- Customer Relationship Management (CRM), which is used to manage relationships with consumers, including the collection, storage and analysis of information about customers, suppliers, partners, and information about relationships with them.
- Enterprise Asset Management (EAM), which can effectively manage all lifecycle, improve resource utilization and reduce costs by using powerful analytics tools.
- Business Intelligence (BI) & Online Analytical Processing (OLAP), which allows converting streaming business information into human-readable form.
- E-Commerce System, which manages activity of all electronic financial and trading transactions, as well as related business processes.

In general, there are three main areas that determine the development of the class ERP II: deepening the functionality of ERP; the emergence of technologies that simplify the creation of specialized industry solutions; creation of new and improvement of existing management modules between corporate business processes.

Our system analysis revealed that the main differences between ERP and ERP II arose from the rapid development of e-commerce and increased interaction between all subjects of financial and business processes via the Internet, so the modern system received a Web-based architecture (Fig. 2).

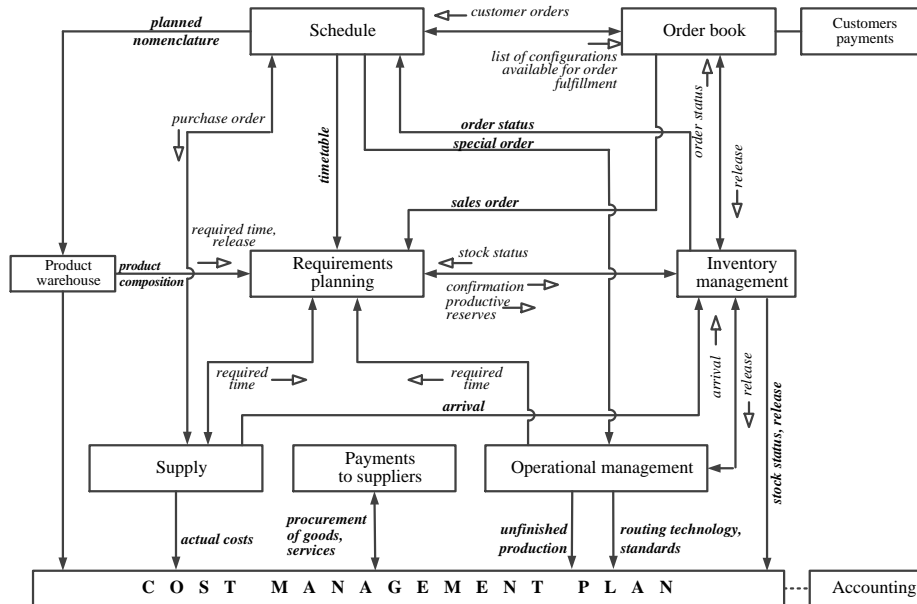


**Fig. 2.** Differences between ERP and ERP II<sup>4</sup>

In our opinion and in the opinion of many scientists enterprise resource management requires a comprehensive review of all business processes within a single information system [4, 6, 9, 11, 19]. The absence of functions important to the enterprise in the system and the impossibility of their additions for a certain period of time - indicate the inexpediency of its implementation at this enterprise. And because of this, in the face of increased competition, it is necessary to find out the real needs of the enterprise from the function of modern ERP and to develop and describe the sequence of such a system, to determine the need for individual blocks of automation of business processes.

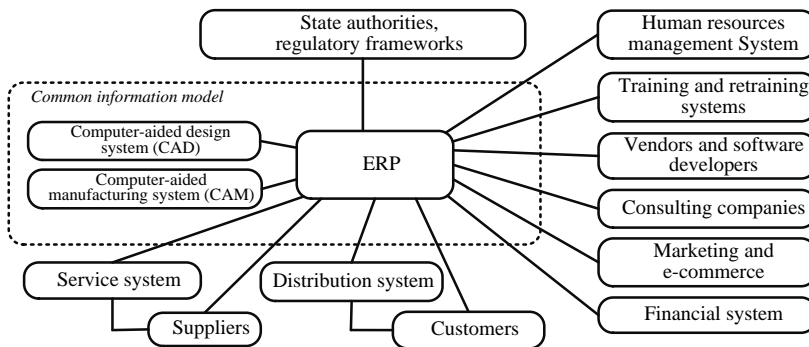
We have proved that an important aspect of implementing the chosen ERP is the level of integration between its subsystems. As an example, consider a scheme of integration of subsystems based on information flows (Fig. 3).

<sup>4</sup> Systematized by the authors based on [1, 5, 13]



**Fig. 3.** An example of the integration of subsystems based on information flow<sup>5</sup>

At the same time, we believe, it is necessary to be aware how the chosen enterprise management system integrates with external objects and systems (Fig. 4).



**Fig. 4.** An example of interaction of ERP system with external entities and their systems<sup>6</sup>

With schemes given above and on the basis of functional features one can create an implementation plan of all subsystems, which eventually will become a powerful tool for managing financial and economic activity of the enterprise.

<sup>5</sup> Built by the authors, based on the analysis of the functional structures of industrial enterprises of Khmelnytskyi region

<sup>6</sup> Built using [1, 6, 13]

## 5 Criteria of Criticality, Readiness, Speed and Costs in the Enterprise Management System

The analysis shows that most companies are choosing ERP for help with specialized consulting companies, but even with the involvement of external consultants, the company should also attract its own experts who can influence the final decision.

Among the wide range of criteria to select the ERP system should be the following: functionality of the system; total cost of ownership (acquisition costs, implementation and support); guarantees of successful implementation; reliability, performance, system perspective; efficiency and payback period of the project; support level by integrator after implementation; level of service and the possibility of further development of the system by our own specialists. The maximum effect after implementing ERP is potentially dependent on selected priorities in automation of business processes at the enterprise. In our opinion, analysis of possible automation steps should be carried out according to the criteria of criticality, readiness, speed and cost.

With the criticality criteria one can identify "problem areas" in the company, usually subsystem of sales, marketing and advertising are analyzed to attract new customers and retain existing ones. To enhance the efficiency of controlling over financial resources you must first carry out automation of financial management and cost of production. First and foremost, priority should be given to automation "problem areas" in view of the relationship of their business processes with other enterprise activities (Fig. 5).

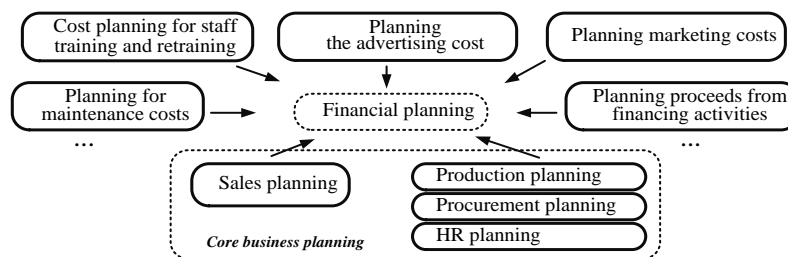


Fig. 5. Automation of the functioning of the financial and economic management<sup>7</sup>

Research [10, 16, 17, 18] shows that automation of financial and business enterprises can improve not only the effectiveness of operational control over the use of funds, but also increase the effectiveness of sales and management subsystem, procurement personnel management subsystem, marketing activities management subsystem, etc. It may not be promising to develop your own automation block, but to integrate an already existing module.

Here, in our opinion an important evaluation criterion is the readiness of enterprises to introduce an integrated information system, which consists of professional and psychological readiness of employees and managers. Lack of professional readiness could lead to the rejection of the project or hiring third-party developers that will increase the cost of implementation. Psychological readiness may be due to a signifi-

<sup>7</sup> Suggested by the authors

cant increase in the functional responsibilities of staff and promote responsibility, especially at the stage of development and implementation.

Another criterion that we have defined is speed implementation solution, when automating site is chosen because of the simplicity of the design and subsystems implementation.

Cost component is generally perceived by management as an investment, and taking into account the fact that ERP has a modular structure, it is recommended to start a project with low-cost modules, in order not to risk losing the invested funds if for some reason the project fails. Therefore, ERP introduction should be carried out on areas of the enterprise where the maximum economic effect is expected, the implementation process will take place quickly and with minimal cost, and the staff is ready to change and will be able to use benefits.

Selecting the type of ERP is difficult and responsible task, since these systems are usually implemented for quite a long time (the average lifetime is 9 years) [5], they should have expected functionality and reasonable price.

When purchasing ERP, you must consider the TCO, which in turn consists of the following costs [4, 7, 16, 17, 19]: preparations for the project (audit of the company, development of technical specifications, modeling etc.); installation, adjustment and adaptation of the system to the specifics of the enterprise; simulation, testing and experimental exploitation; purchase and installation of necessary equipment; training (users and support personnel for follow-up); hiring additional staff technical support of the system; transferring data from the previous system; ongoing maintenance and support (salaries, purchase or repair of equipment, etc.); maintenance services from a company-developer (hourly consultations, urgent revision etc.).

Since these types of costs can increase the cost of the system by times, compared with the cost of the software itself, therefore, it is necessary to make a full pre-calculation of costs.

## **6 Use of Advanced Development Tools and Support of Economic Security**

The analysis of information technology used in ERP is equally important. If the system is based primarily on its own development, then there may be a strong dependence on the supplier company [1, 4, 19]. In our opinion, it is advisable to use proven technologies, especially those oriented at industry. Especially for large and medium enterprises we need to focus on the level of implementation of "client-server" architecture using powerful database management systems of Oracle, IBM and Microsoft companies.

Considering the current tendency to increase competition in the market, you should also take care of the security system to prevent unauthorized access and so on. It is necessary to examine mechanisms for data exchange between structural divisions, set a distributed data access, organize work in the sphere of identifying leaks or external threats and so on. Of course, the organization of information security is based not only on the use of software, but also on logistical organization, users' experience and their corporate culture.

Effective functioning of ERP depends on the quality of service, including: the ability to select the necessary and appropriate level of service for the customer; prompt response to requests and ordered system of control over them; providing advice in real time; completeness of orders execution; free and prompt elimination of errors by the developer; availability of favorable conditions for the supply of new versions, etc. [14, 16, 17, 18].

Research has shown that for automation systems of large and medium enterprises in Khmelnytskyi region, the quality of service and support comes to the fore in the long run, and so, when choosing ERP, you can sacrifice a certain functionality of the system, but not the quality and completeness of the service and support.

In our opinion, as practical recommendations to domestic enterprises, before choosing and implementing an ERP system, you need to use the following criteria and pre-verify: the completeness of reflection in the system of national legislation, the compliance with the procedure for the implementation of operations adopted in the enterprise, the clarity of the interface and documentation to users, the functionality of the system on similar enterprises, taking into account branch characteristics and specifics of own production, the possibility of branching out within affiliates, integration with other management systems.

## **7 Conclusions**

Based on the research and analysis of existing scientific approaches, the article assesses the advantages of implementing the ERP system at the enterprises of mechanical engineering, expertly determines its most significant impact on individual indicators of the enterprises, determines the main criteria for modern management system requirements to compliance with the resource planning concept. The authors offered scientific and methodological approach to the application of planning methods for various types of production depending on the volume of output and assortment, and also described the advantages and disadvantages of automating business processes at the enterprises in Khmelnytskyi region depending on the individual types of automation. The article defines a list of modules that appeared in modern ERP II, singles out differences between ERP and ERP II, and also provides examples of integration of subsystems based on information flows and interactions with external business entities. The authors systematized the criteria for providing benefits of the development or acquisition of ERP and suggested the use of advanced tools for developing and maintaining the economic security of enterprises, and presented practical recommendations on the use of ERP at the enterprises.

The results of the conducted research confirm that the introduction of the modern ERP-system at the enterprise allows you to obtain competitive advantages and ensures compliance with modern world standards for improving the company's rating, leads to an increase in the market segment, sales growth, creates the ERP-system compliance with the expectations of the head of the company, because it is the head of the enterprise who is responsible for setting the task and goals. The introduction of the modern ERP-system also finds the factors of the false work of some departments of the enterprise; weakens internal audit, as the quality of external audit increases.



## References

1. Aldzhanov, V.: IT-architecture from A to Z: Theoretical basis [e-book]. Publ: Ridero. 396 p. (In Russian) (2018).
2. Almajali, D.: Antecedents of ERP systems implementation success: a study on Jordanian healthcare sector. *Journal of Enterprise Information Management. Emerald.* 29 (4), (2016), <http://www.emeraldinsight.com/doi/full/10.1108/JEIM-03-2015-0024>, last accessed 2019/01/06.
3. APICS Dictionary. The essential supply chain reference, <http://apics.org>, last accessed 2019/01/02.
4. Chase, R.B., Aquilano, N.J., Jacobs, F.R.: *Production and Operations Management*; transl. from English. Moscow. Publ. "Williams". 704 p. (in Russian) (2004).
5. ERP Selection: Finding the Right Fit, <http://aberdeen.com/Aberdeen-Library/7701/RA-enterprise-resource-planning.aspx>, last accessed 2014/02/20.
6. Golitsina, O. L., Maksimov, N. V.: *Information systems*, Moscow, Publ. "Infra-M" (in Russian) (2009).
7. Ivakhnenkov, S. V.: *Information technologies of audit and internal control in the context of world integration*. Scientific publication, Zhytomyr, Publ. "Ruta" (in Ukrainian) (2010).
8. Kolesov, A.: Gartner on the world market for average ERP solutions, *Journal "PC Week"*. Vol. 29-30, 683--684 (in Russian) (2010).
9. Lavinsky, G. V., Obolenskaya, T. E., Marinchenko B. V.: *Automated systems for processing economic information*, Kyiv, Higher School (in Ukrainian) (1995).
10. Lee J. Krajewski, Larry P. Ritzman, Manoj K. Malhotra: *Operations Management: Process Chain and Value Chains*, 8th Edition, Pearson Education, Inc. (2007).
11. List of National Standards of Ukraine for the creation, implementation and maintenance of automated and information systems, <http://nbuv.gov.ua/node/1469>, last accessed 2019/01/14.
12. Lysenko, O. A., Lysenko, V. V.: *Topical issues of implementation of ERP-systems at domestic enterprises in modern market economy* (in Ukrainian) <http://ir.nmu.org.ua/handle/123456789/149397>, last accessed 2018/11/07.
13. O'Leary, Daniel E.: *ERP systems. Modern planning and management of enterprise resources. Selection, implementation, operation*. Moscow, Publ. "Vershina" (in Russian) (2004).
14. Rosemann M., Wiese J.: *Measuring the Performance of ERP Software: A Balanced Scorecard Approach*. Proceedings of the 10th Australasian Conference on Information Systems (Wellington, December 1-3, 1999). P. 773--784 (1999).
15. State Agency for E-Governance of Ukraine (in Ukrainian) <https://www.e.gov.ua>, last accessed 2018/12/03.
16. Vasylykiv N. M.: *The effectiveness of information systems*. Ternopil. Publ: *Economichna dumka*. 98 p. (in Ukrainian) (2005).
17. Vereskun, M. V.: *Methods of evaluation of the efficiency of implementation of information systems at industrial enterprises*. *Journal Theoretical and practical aspects of economics and intellectual property*. Issue: 1(11), P. 21--26 (in Ukrainian) (2015).
18. Yemchuk, L. V.: *Analysis of the factors determining the effectiveness of the implementation of the information system in the enterprise*. *Journal of Dnipro university. Series: Economic*. Issue: 4, Part. 21. P. 76--82. (in Ukrainian) (2013).
19. Yurinet, V.: *Automated Information Systems in Finances*, Lviv, Publ. "LNU named after Franko" (in Ukrainian) (2004).

# Business Models of Reproduction Cycles for Digital Economy

Leonid Melnyk<sup>1</sup>[0000-0001-7824-0678], Oleksandr Derykolenko<sup>1</sup>, Oleksandr Kubatko<sup>1</sup>[0000-0001-6396-5772], Oleksandr Matsenko<sup>1</sup>[0000-0002-1806-2811]

<sup>1</sup> Sumy State University, Sumy, Ukraine  
melnyksumy@gmail.com, venture.sumy@gmail.com, okubatko@ukr.net,  
amatsenko@econ.sumdu.edu.ua

**Abstract.** The intensive use of non-renewable resources and torn technological cycles is the cause for the total destruction of the planet's ecosystems. The transition of production systems to renewable resources and closed circular cycles can ensure long-run sustainability of economic activities. Circular technologies as the basis of business processes guarantee sustainable transformation of the usual economy to digital one. The reproduction of economic activities in the closed integral cycle "production-interfacing-consumption-recycling-production" is the principal condition for the successful functioning of business processes. The scientific grounding, design and practical implementation of reproductive circular business processes create the platform for building a digital economy and ensures ecosystems sustainability.

The research focuses on the modeling, design and practical implementation (introduction, testing, refinement, and adaptation to specific conditions) of reproductive circular business processes. The research models economic activity and communication of the economic agents in the main areas of the digital economy.

**Keywords:** informational factors, networking, digitalization, reproduction, phase transition.

## 1 Digital Economy Production Features

### 1.1 Key Transformation Factors

The digital economy differs from the traditional one through a significant increase in the number of transactions. The last is due to the vanishing of geographical barriers in the information society. Trading with minimal transactional costs in real time situations is possible. The emergence of digital platforms like Amazon, Airbnb, Uber, eBay, and access to them through mobile smartphone applications made the exponential growth of world trade [1]. Globalization and open competition lead to an increase in the level of competition between producers of goods and services. In the digital environment, the higher survival rates could be achieved only with constant improvement/changes in business models (which is difficult for large enterprises).

Humanity has passed several decisive stages of development and organization. At the first stage, we lived in different nomadic tribes; on the second - we gathered in the settlement (villages and towns), engaged in agriculture; on the third (thanks to steam traction, industry, and transport) we increased human mobility and increased trade. Today, with the Internet, social networks and various digital trading platforms, everyone can be connected.

Several key factors mark the transition to the information society. First, the central element of production and consumption is information (hence, the primary economic system to which humanity is directed named "information economy"). Second, the material influence of a person on the planet ecosystem decreases with times (hence, the second name of the new economy is the "green economy"). Thirdly, there is a continuous network of production and public life (because of this the third name of the state is the "network economy").

With the transition to the informational economy, all three groups of system-forming factors are being changed: material-energy, informational, and synergetic. In particular, within the first group the most significant events are the transition to renewable energy ("green") and the formation of additive technologies based on 3D printers. In the second group, the decisive transformations are computerization and transition to digital forms of fixation of information, the creation of production cyber-physics systems, and cloud technologies. The third group of changes is represented by networking between production systems, virtual firms operation, the formation of horizontal production and consumer systems, and the formation of the Internet of things. Based on the transformations mentioned above we could state that the current economic system is possessing postindustrial, digital and cognitive features.

The global transformation of socio-economic processes demands a constant transformation of existing business models. In the digital economy, the laws of classical economics, based on limited physical resources cease to work. The main resource of the digital economy is data and information, the main capital of the digital economy is ideas and knowledge. In such circumstances, changes take place at a higher pace, changing the culture of business, approaches to management and organization of companies.

*The purpose of our work* is to formulate theoretical approaches to the transition of economics and society to new business models of reproduction cycles under the conditions of the digital economy. This transition is necessitated by intensification of global competition and technological companies that have arisen or adapted in a digital transformation have to switch to innovative business models.

## 1.2 Phase Transition to a New Economy

Many empirical facts prove the movement of economic life to new realities. Thus, the share of energy produced from renewable sources reaches 25 percent [2], and in many countries (in some periods), it reaches 100 percent [3-5]. Currently, around 30 countries have achieved the level of energy efficiency when renewable energy costs are cheaper than traditional ones [5, 9-11].

By the end of the 1980s, only one percent of the information in the world was in digital form, by 2014, this share reached 99 percent [7].

In 1990, the Internet served only 0.05% for the Earth's population. In 2016, this number exceeded half the planet's population [7].

Broad access to the Internet, the development of social networks contributed to total access to data and information. Most markets have become virtual, business models have been built on ideas.

Under the business model of reproductive cycles in a digital economy, we understand such a model, which is a way of implementing business ideas on digital platforms and is based on the use of predominantly information resources with the purpose of reducing the cycles of reproduction (production, transportation, storage and sale of products, as well as its consumption and recycling). In a digital economy the competitive advantages are generated by intellectual capital (the combination of human capital and technology), the basis of reproductive cycles are business ideas, and the main resource is large amounts of Big Data and information.

The short review of this paper allows us to cover only some aspects of digital society problematic issues. The most urgent problem of the transition to the digital economy is the formation of a renewable mechanism for economic system operation.

## 2 Models of the Digital Economy

The specific feature of the digital economy model is customer-centricity. This foreseen not only the orientation of the business to meet demand by satisfying the needs of the client, but it includes the transformation of the business structure itself. Thus, customers are given the opportunity to create a digital and even business-friendly environment. The client can configure groups of trading partners, social environment, etc. and become a full member of the business environment. In the research literature [7, 8] the digital economy distinguishes the following business models:

- *Business models of joint participation*, based on joint use (lease, sale, exchange). Such models lead to a significant increase in social, economic and environmental efficiency. An example is the BlaBlaCar fellow travel companion service.
- *Business models based on technology and co-management*. These models lead to optimization of demand and supply. For example, mutual credit services.
- *Business models that focus on a set of a critical mass of users to analyze large data*. Such models are the most attractive for investing. An example can be the service for renting a private non-movable Airbnb.
- *Business models of sharing space and time*. The last one is based on the creation of the technological zones infrastructure for joint entertainment, creativity, project implementation. For example, the technical area of TalantGarden.
- *Business models are aimed at optimizing business processes*. For example, the logistics company LardiTrans has developed a convenient platform for combining the interests of carriers and cargo owners.

The above-mentioned business models create threats for traditional industries. Many of the traditional businesses are not ready for such rapid changes. For example,

traditional hostels or taxis could not understand the nature of digital transformation and offer no strategic responses to confront new threats. For example, we could analyze the post-soviet countries, when their products in the open digital environment are absent or presented with non-competitive commodities in comparison with its price. It must be recognized that the digital transformation of business must be based on constructive product changes, which is a source of value added increase. Such changes can only be achieved by creating a digital and creative staff, which could generate ideas for the quality of the goods being produced. To provide a digital flexibility, enterprises need to implement the total digitalization of production and marketing; that is, the creation of a digital foundation for business.

The speed of innovative changes implementation is on the edge of the digital economy. The last is necessary for the rapid conquest of the market sectors, which has become possible due to digital trading platforms. Today, you can win millions of users in a few days and create a threat to other companies.

### 3 The Model of Renewable Production Cycles

Considering the turbulent changes in economic development, it is necessary to guarantee the shift from traditional production and consumption of goods and services to constant reproduction of producer-consumer cycles based on information technologies.

Schematically, the scope of information factors in the reproduction cycle has the form: "production - interface sphere (technology transfer, transport, storage, trade) - consumption - postproduction sphere" (fig. 1).

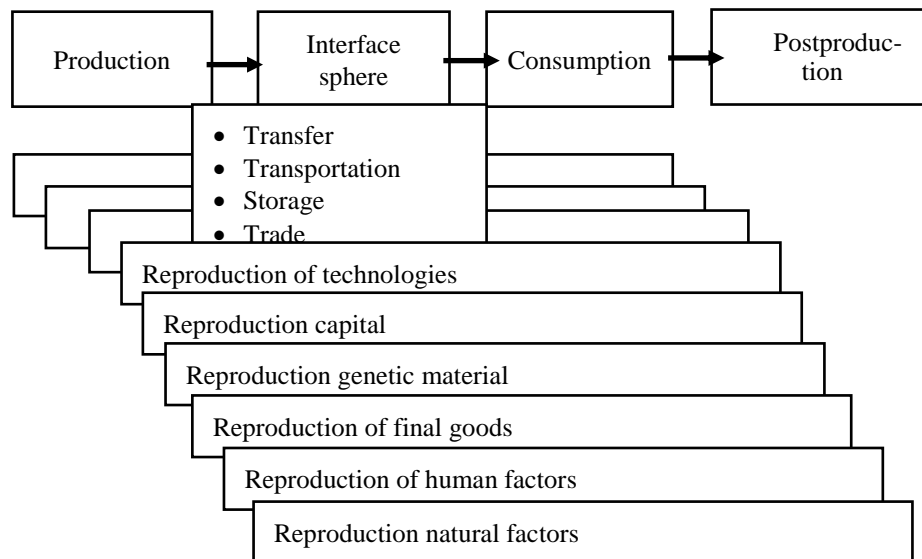


Fig. 1. The influence of informational factors activities

At the same time, this cycle may relate to the reproduction of a wide range of assets: technologies, means of production (including information), final products, human capital, consumer cycles, and natural factors.

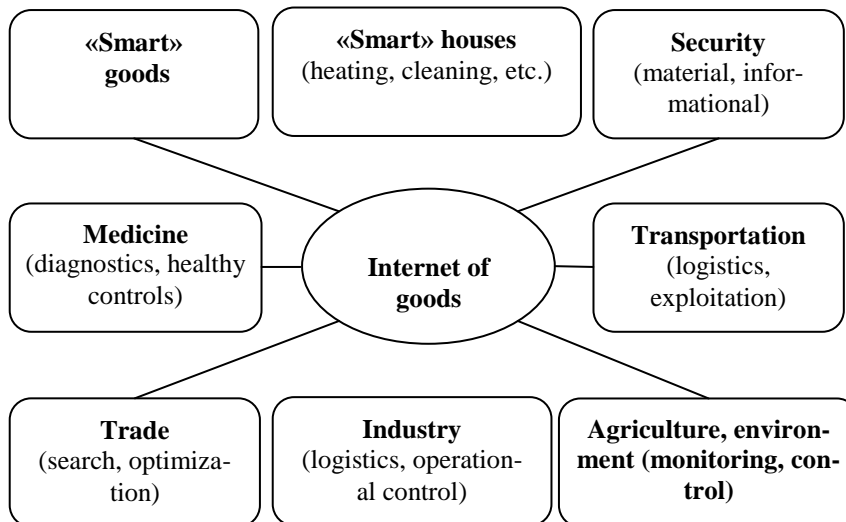
The process of modern production should be a system that reproduces the essential interconnected elements. The main components of the reproductive mechanism of production can be attributed to:

- reproduction of demand;
- reproduction of the production basis;
- reproduction of human factors;
- reproduction of motives.

The indicated reproduction mechanism can be realized only under the influence of the constant operation of organizational, economic and social instruments that will contribute to the digital transformation of the components of the economic system and the processes.

It should be emphasized that informational factors are the key ones in the production sphere forming, shaping its basic parameters (technology, product design, source materials, natural conditions, means of production, space and time parameters, communication, personal potential, motives of work, level of synergy, management potential, institutes, etc.).

A significant competitive advantage of modern products is its integration into the Internet of things (Fig. 2), which allows controlling individual stages of the reproduction cycles.



**Fig. 2.** Spheres of the Internet of thing applies

The participation of information factors in the functioning of a modern enterprise is related to the implementation of specific functions, in particular:

- Formation of information program (code) for operation in space and time;
- System adaptation of the changing internal and external environment;
- Implementation of operational activities;
- Integration of individual collaborators;
- Reproduction of physical and mental properties of performers;
- Innovative reproduction (product, technology, means of production, knowledge, skills).

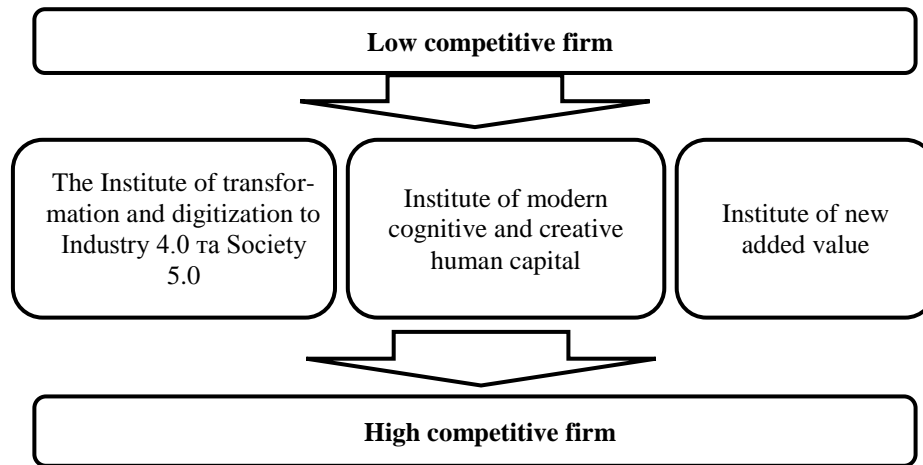
The critical role for digital technologies is given to human capital re-production and the formation of individual characteristics (social memory, horizons, professional competences, communication skills, self-learning skills, leadership skills, ability to self-reproduce, motives). Information factors are decisive at modern consumption pattern formation (knowledge, interests, needs, demand, skills, ethics, social responsibility, infrastructure, communication, solvency, institutions). The caring capacity of all information factors is digitization. In a digital economy, modern enterprises do need to digitize the production processes. Moreover, the digitization should achieve to the institutional level (Fig. 3), which is oriented to the standards of Industry4.0 and Society 5.0.

The digitization has to cover first of all the following:

- Interconnection with suppliers should be implemented on a competitive basis through digital tenders. The last creates the potential to influence the provider image through the ability to provide digital ratings and ratings.
- Means of production and communications in the production process. This will help to increase the quality of controlling to establish feedback between staff and means of production and predictive analyses of production processes in general.
- Sales channels. A modern enterprise can use platforms that allow access to potential buyers and customers. Today it is not enough to limit itself to advertising in social networks. It is necessary to create conditions for the deep interaction between the client and the enterprise.
- Management processes. Digitizing of production, marketing processes, and modern management are faced with Big Data. The demand for business intelligence and programmers in the field of Machine Learning is growing. Specialists who are capable of obtaining data and presenting it in a convenient perception form for decision making are urgently needed.
- Forecasting processes. Digital tracking of the market and focus on the best technologies is key to strategic planning.

The Institute for Transformation and Diversification of the Economy to the Levels of Industry 4.0 and Society 5.0 foresees:

- the development of innovative information technologies to create new value-added products, focusing on the development of the Internet of Things (IoT), artificial intelligence (AI) and robotics;
- creation of secure digital platforms for retail exportation;
- development of the local application of digital solutions;
- implementation of digital solutions in industry and society as a whole;
- digitization of socio-ecological and economic processes.



**Fig. 3.** Capacity building model for competitiveness improvement in conditions of the digital economy

The second institute of modern business is human capital - the main reproductive factor and generator of ideas and innovations. It is the human capital that creates competition between states. In this case, developed countries have created appropriate ecosystems to stimulate the development of the digital economy, which is aimed at attracting the best specialists in the world. The world's leading countries are taking advantage of the digital economy to manage human resources: The United States is building a global surveillance system; Israel creates a supervisory regime on the West Coast; The Russian Federation influences the opinion and choice of people around the world; China is strengthening the internal system of control over society by collecting data and building a network of internal ratings of citizens.

Therefore, the institution of a new cognitive-creative human capital should be oriented towards:

- New methods of training and preparation of cognitive-creative intellectual capital of human capital.
- Raising the welfare of human capital;
- Innovative methods of the positive motivation of human capital;
- Providing a high-quality, safe environment for the existence of human capital.

Finally, the Institute of new value-added includes:

- Deep processing of natural resources and agricultural products;
- Creation of high-intellectual goods and services;
- Business development;
- Creation of high-performance jobs;
- Support for a new product that meets modern quality standards.

Consequently, the main drivers for the development of a modern firm are the institutions aimed at digitization; ecosystems (forming the infrastructure for support and acceleration of innovations, development of digital entrepreneurship); motivational complex, aimed at introducing incentives for human capital and business to digitization; training and competency building (lifelong learning and digital competency development for better use of digital opportunities).



## 4 Conclusions

Modern production should be based on fast information reproduction, which is realized through the formula: information product production (by information technologies) for information consumer. 2. Modern economic systems are an incredibly dynamic reality. This is due to the constant reproduction of the production and consumption cycles and its components: consumer style, product, technology, means of production, competencies, and methods of nature use. 3. The most profitable sphere of modern production is the generation of such informational products like innovation. 4. Ukraine has (and partially implements) a powerful potential for production and export of innovations. An example is the organic agro-industrial complex, space sphere, IT technology, and creative economy.

## References

1. Nathan F., Jeff D., Clayton M. C.: *The Innovator's Method: Bringing the Lean Start-up into Your Organization*. Harvard Business Review Press (2014).
2. Hill, J.: Renewable Energy Now Accounts For 30% Of Global Power Generation Capacity. CleanTechnica, <https://cleantechnica.com/2016/09/20/renewable-energy-now-accounts-30-global-power-generation-capacity>, last accessed 2019/03/21.
3. Bolton, D.: People in Germany, are now being paid to consume electricity: The price of power in Germany briefly dropped to -€130 per MWh on 8 May. INDEPENDENT, <http://www.independent.co.uk/environment/renewable-energy-Germany-negative-prices-electricity-wind-solar-a7024716.html> last accessed 2019/03/21.
4. Johnston, A.: Portugal runs on 100% renewables for four days. Clean Technica, <https://cleantechnica.com/2016/05/21/100-renewable-electricity-portugal-4-days>, last accessed 2019/03/21.
5. Scotland Just Generated More Power Than It Needs From Wind Turbines Alone). Science alert, <http://www.sciencealert.com/scotland-just-generated-more-power-than-it-needs-from-wind-turbines-alone>, last accessed 2019/03/21.
6. Renewable energy has become cheaper than oil and gas already in 30 countries. DW. Made for minds / News / World, <https://p.dw.com/p/2Utev>, last accessed 2019/03/21.
7. Digital Revolution, [https://en.wikipedia.org/wiki/Digital\\_Revolution](https://en.wikipedia.org/wiki/Digital_Revolution), last accessed 2019/03/21.
8. Muñoz, P., Cohen, B.: Mapping out the sharing economy: A configurational approach to sharing business modeling. *Technological Forecasting and Social Change* (2017).
9. Melnyk L., Kubatko O.: The EU experience for economic systems adaptation to resource fluctuations through green industries innovations. *Actual Problems of Economics* 12, 36--42 (2013).
10. Sineviciene, L., Sotnyk, I., Kubatko, O. Determinants of energy efficiency and energy consumption of Eastern Europe post-communist economies. *Energy & Environment* 28 (8), 870--884 (2017).
11. Karintseva, O.I. Economic restructuring in Ukraine in view of destructive effect of enterprises on environment. *International Journal of Ecological Economics and Statistics*. 38 (4), 1--11 (2017).

# Support of Investors' Decision Making in Economic Experiments Using Software Tools

Daria Kilinich<sup>1[0000-0001-6411-905X]</sup> and Vitaliy Kobets<sup>1[0000-0002-4386-4103]</sup>

<sup>1</sup>Kherson State University, 27 Universitetska st., Kherson, 73003 Ukraine  
vkobets@kse.org.ua, daria.kilinich@gmail.com

**Abstract.** During making decision the logit and probit patterns serve to resolve different issues based on statistical data regarding expediency or inappropriateness: opening LTD, investing funds, hiring employees, entering a new market, introducing innovations, etc. The purpose of the research is to support the decision making in economic experiments using software tools and logit and probit analysis. To achieve this goal, the following tasks are defined: investigation of the range of application of the logit and probit models; calculation of open data using the RStudio; development of decision support models using open data sources.

Methods and technologies of research: logit and probit models to predict the probability of dealing between traders of cryptocurrencies, cluster analysis of investor profiles through principal component analysis.

To distinguish different types of investors we can use cluster analysis which help us to reveal main types of risk-attitude investors. After that we can construct correspondence between specific users and financial instruments.

**Keywords:** decision making, economic experiments, software tools, cryptocurrencies, cluster analysis

## 1 Introduction

We studied criteria which affect prices of cryptocurrencies [1] and found out that combination of supply, mining difficulty, trading volume, and news reaction for each date can predict more than 70% of the price (we used Bitcoin for research). R.C. Philips and D. Gorse studied how to predict cryptocurrency prices bubbles using epidemic modeling and human reaction on social media [2].

Also, S. Colianni, S. Rosales, and M. Signorotti investigated cryptocurrencies algorithmic trading techniques based on Twitter sentiments analysis [3]. C. Lamon, E. Nielsen, and E. Redondo studied cryptocurrency price changes based on news and Reddit sentiments [4]. Kim YB et al. in 2016 did significant research about how users activities in communities affected prices of cryptocurrencies [5].

All researches we have mentioned above show that users activities affect prices. However, we applied a different approach in this research. Our idea was to predict cryptocurrencies prices based on their daily trading volume.

The decentralized digital currency Bitcoin presents an anonymous alternative to the centralized banking system and indeed enjoys widespread and increasing adoption

[6]. The digital currency market is considerably growing, especially in the most recent years. Level of uncertainty in returns has significantly increased during the high-price time period. The high-price regime phase has profoundly revealed consistent nonlinear dynamical patterns in the Bitcoin market [7]. The virtual currency supply is exogenous and therefore plays only a limited role in the price formation. Bitcoin is a digital currency based on a peer-to-peer payment system managed by an open source software and characterized by lower transaction costs, greater security and scalability than fiat money and no need of a central bank [8]. Bitcoin will remain a niche currency. Authors [9] analyze the time-varying behavior of long memory of returns on Bitcoin and volatility 2011 until 2017, using the Hurst exponent. R/S method is prone to detect long memory. Price volatility, measured as the logarithmic difference between intraday high and low prices exhibits long memory during all the period. This reflects a different underlying dynamic process generating the prices and volatility.

The creation of cryptocurrencies has changed FinTech industry and it continues to change it today, whereas people think that during 9 years nobody has found the real use of cases for blockchain technology [10]. Now people still depend on banks, because most countries did not define cryptocurrencies as national currencies; but in the future the decentralized systems, such as Bitcoin, can substitute traditional currencies. Also, due to continuously increasing digital society, financial services providers are looking to offer their customers the same services to which they are accustomed but in a more efficient, secure and cost-effective way.

In addition to mining (the process of extraction of the cryptocurrency), trading with cryptocurrencies is popular nowadays. It is risky but on the other hand, it is a fast way to get a great sum of money. For example, at the beginning of 2017, Bitcoin cost lower than \$1000 but in December 2017 it cost almost \$20000.

The **purpose** of the paper is to support the investors' decision making in economic experiments using software tools.

The paper is organized as follows: chapter 2 characterizes logit and probit models for data analysis; chapter 3 includes analysis of cryptocurrency data for trading; chapter 4 describes cluster analysis for investors' profiles that plan to invest in cryptocurrencies; the last part concludes.

## 2 Logit and Probit Models for Data Analysis

Logit model is a regression model, where a dependent variable can have only two alternative values "0" and "1". If dependent variable has more than two alternative results can be analyzed in a multi-vector logistic regression. In economic sense logistic regression is an example of a qualitative response to a discrete choice of decision maker. The probability of an event is determined by the function (1):

$$p_i = F(Z_i) = \frac{1}{1 + e^{-Z_i}} \quad (1)$$

where Z is a linear combination of independent factors.

The probit model is most often evaluated by probit regression using the maximum-likelihood method. Assume that the response variable Y is binary, that is, it can have

only two possible results, which we will denote as 1 and 0. We also have a regression vector  $X$ , which affects the result  $Y$ , then the model takes the following form (2):

$$\Pr(Y = 1|X) = \Phi(X^T \beta), \quad (2)$$

where  $\Pr$  – probability;  $\Phi$  – cumulative distributive function of standard normal distribution;  $\beta$  – parameters of maximum-likelihood estimation. In the matrix form the regression will take following form:

$$Y^* = X^T \beta + \varepsilon, \quad (3)$$

where  $\varepsilon \sim N(0, 1)$ . Then  $Y$  can be considered as expression (4) if hidden variable is positive:

$$Y = \begin{cases} 1 & Y^* > 0 \\ 0 & \text{other} \end{cases} = \begin{cases} 1 & -\varepsilon < X^T \beta \\ 0 & \text{other} \end{cases} \quad (4)$$

The use of a standard normal distribution does not lead to loss of universality versus the use of arbitrary standard and average deviation, since the addition of a fixed amount to the average can be offset by subtracting the same amount. The equivalence of the two models has following form:

$$\Pr(Y = 1|X) = \Pr(Y^* > 0) = \Pr(X^T \beta + \varepsilon > 0) = \Pr(\varepsilon < X^T \beta) = \Phi(X^T \beta) \quad (5)$$

Because the logit [11] and probit models [12] are very similar to each other, the algorithm for constructing them is the same:

1. Determination of the dependent variable and factors
2. Construction of an independent variable, as a linear combination of independent variables
3. Specification of the equation for the desired probability of an event
4. Conducting calculations (maximum-likelihood method)
5. Interpretation of results and evaluation of quality assessment

The differences between the logit and the sample of models are in the specification of the random component  $\varepsilon_i$ , namely [13]:

1. in the probit of the model  $\varepsilon_i \sim N(0,1)$  (standard random variables with mathematical expectation 0 and dispersion 1)
2. in the logit of the model  $\varepsilon_i \sim \text{logistic}$ ,  $f(t) = e^{-t} / (1 + e^{-t})^2$  (special logistical distribution  $N(0, 1.6^2)$  with mathematical expectation 0 and dispersion  $1.6^2$ )

Let's consider how price of cryptocurrencies impacts on decisions of potential clients to buy ('1') or not to buy ('0').

### 3 Analysis of Cryptocurrency Data for Trading

Investigation of the dependence of the purchase and sale of cryptocurrency. Data for the calculation was obtained from a public site, <https://finance.yahoo.com/cryptocurrencies> (fig. 1).

It has been selected 5 the most popular cryptocurrencies such as: BTC (Bitcoin), ETH (Ethereum), BCH (Bitcoin Cash), LTC (Litecoin), NEO.

Entering as a dependent alternating  $Y_{i(1-5)}$ , equal to 1 to indicate that the currency has been purchased and 0 that shows that the cryptographic currency has not been purchased [14]. Introduced explaining variables in order to show the course of this or another cryptocurrency from the first November 2017 till the 30th April 2018 (fig. 2):  $X_1$  - BTC,  $X_2$  - ETH,  $X_3$  - BCH,  $X_4$  - LTC,  $X_5$  - NEO.

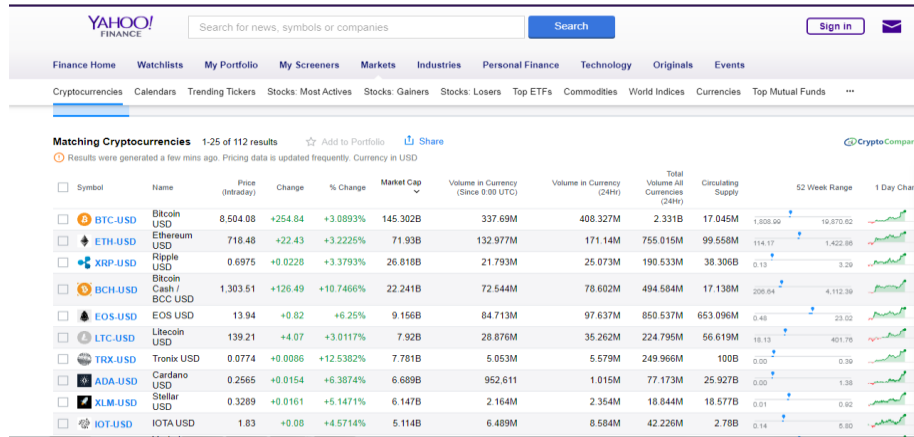
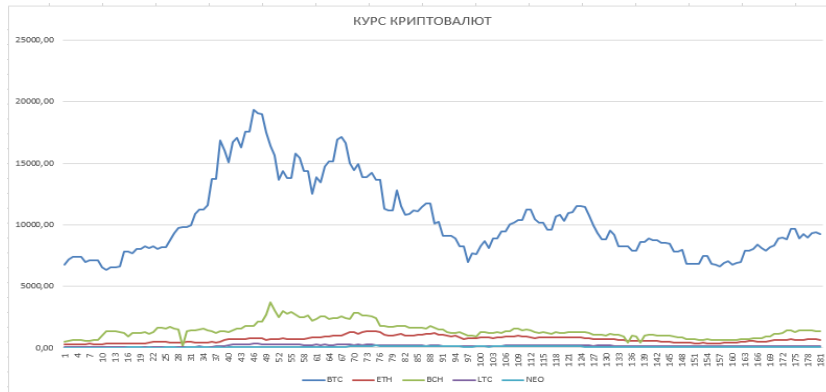


Fig. 1. Web-site of cryptocurrencies: <https://finance.yahoo.com/cryptocurrencies>

	A	B	C	D	E	F	G	H	I	J	K	L
	№	Дата	X1 (BTC-USD)	Y1	X2 (ETH-USD)	Y2	X3 (BCH-USD)	Y3	X4 (LTC-USD)	Y4	X5 (NEO-USD)	Y5
1	1	01.11.2017	6737,78	1	284,92	1	529,88	1	54,19	1	24,62	1
2	2	02.11.2017	7152,12	1	304,51	1	562,79	1	55,98	1	26,67	1
3	3	03.11.2017	7363,80	1	300,04	1	626,04	1	54,60	1	26,44	1
4	4	04.11.2017	7363,80	1	296,82	1	614,26	1	54,60	1	26,24	1
5	5	05.11.2017	7389,55	1	291,84	1	625,72	1	54,50	1	26,23	1
6	6	06.11.2017	6959,23	1	307,35	1	588,68	1	60,52	1	26,15	1
7	7	07.11.2017	7102,75	1	319,66	1	603,26	1	62,38	1	30,10	1
8	8	08.11.2017	7129,59	1	296,86	1	617,41	1	64,15	1	31,89	1
9	9	09.11.2017	7129,59	1	314,23	1	650,09	1	62,14	1	27,97	1
10	10	10.11.2017	6565,80	1	314,60	1	995,40	1	62,14	1	28,39	1
11	11	11.11.2017	6339,86	1	334,72	1	1325,56	1	58,54	1	26,82	1
12	12	12.11.2017	6522,45	1	334,72	1	1374,39	1	61,00	1	28,22	1
13	13	13.11.2017	6522,45	1	331,20	1	1346,96	1	62,13	1	29,59	1
14	14	14.11.2017	6597,06	1	330,32	1	1251,63	1	63,16	1	29,23	1
15	15	15.11.2017	7853,68	1	331,72	1	1187,03	1	70,70	1	28,74	1
16	16	16.11.2017	7853,68	1	346,65	1	896,51	1	67,36	1	40,20	1
17	17	17.11.2017	7699,95	1	354,60	1	1175,54	1	69,42	1	42,93	1
18	18	18.11.2017	8042,64	1	367,71	1	1243,86	1	72,38	1	40,00	1
19	19	19.11.2017	8042,64	1	360,52	1	1176,66	1	69,91	1	35,52	1
20	20	20.11.2017	8244,89	1	380,84	1	1245,28	1	69,91	1	34,37	1
21	21	21.11.2017	8099,97	1	406,57	1	1169,90	1	72,03	1	36,01	1
22	22	22.11.2017	8234,55	1	470,43	1	1298,62	1	72,94	1	34,67	1
23	23	23.11.2017	8013,41	1	470,54	1	1662,21	0	77,54	1	34,76	1
24	24	24.11.2017	8200,80	1	475,24	1	1625,05	0	88,79	1	34,76	1
25	25	25.11.2017	8200,80	1	466,27	1	1546,22	0	90,99	1	38,01	1

Fig. 2. Initial data of cryptocurrency rate

In order to track the dynamics of the cryptocurrency exchange rate at the initial stage of calculations, we have created a chart (fig. 3). With a help of it we can make out that only the BTC has significant fluctuations in value; the other four currencies have minor fluctuations.



**Fig. 3.** Change of the cryptocurrencies rate for 181 days

So let's start work directly with RStudio. Download the data from MS Excel to RStudio (fig. 4):

```
Data <- read_xlsx("C:/RStudio/cr.xlsx")
View(Data)
```

	Дата	INDEPENDENT1	INDEPENDENT2	INDEPENDENT3	INDEPENDENT4	INDEPENDENT5	DEPENDENT
1	2017-11-01	6737.78	284.92	529.88	54.19	24.62	NA
2	2017-11-02	7152.12	304.51	562.79	55.98	26.67	NA
3	2017-11-03	7363.80	300.04	626.04	54.60	26.44	NA
4	2017-11-04	7363.80	296.82	614.26	54.60	26.24	NA
5	2017-11-05	7389.55	291.84	625.72	54.50	26.23	NA
6	2017-11-06	6959.23	307.35	588.68	60.52	26.15	NA
7	2017-11-07	7102.75	319.66	603.26	62.38	30.10	NA
8	2017-11-08	7129.59	296.86	617.41	64.15	31.89	NA
9	2017-11-09	7129.59	314.23	650.09	62.14	27.97	NA
10	2017-11-10	6565.80	314.60	995.40	62.14	28.39	NA
11	2017-11-11	6339.86	334.72	1325.56	58.54	26.82	NA
12	2017-11-12	6522.45	334.72	1374.39	61.00	28.22	NA
13	2017-11-13	6522.45	331.20	1346.96	62.13	29.59	NA
14	2017-11-14	6597.06	330.32	1251.63	63.16	29.23	NA
15	2017-11-15	7853.68	331.72	1187.03	70.70	28.74	NA
16	2017-11-16	7853.68	346.65	896.51	67.36	40.20	NA
17	2017-11-17	7699.95	354.60	1175.54	69.42	42.93	NA
18	2017-11-18	8042.64	367.71	1243.86	72.38	40.00	NA
19	2017-11-19	8042.64	360.52	1176.66	69.91	35.52	NA
20	2017-11-20	8244.89	380.84	1245.28	69.91	34.37	NA
21	2017-11-21	8099.97	406.57	1169.90	72.03	36.01	NA
22	2017-11-22	8234.55	470.43	1298.62	72.94	34.67	NA

**Fig.4.** Entering a table with data for calculations in the program RStudio

To start the calculation of regression and to work with it, we would enter the code of called 'mylogit' [15] (fig. 5) and output the result using the 'summary' function. It is clear due to this function that we want to predict the dependence of buying a cryptocurrency from the value of the rate on it. As an argument we specify: dependent and independent variables; the location of the initial data; 'family' indicates that the distribution type is binomial.

```

> summary(mylogit)

Call:
glm(formula = DEPENDENT ~ INDEPENDENT, family = binomial(link = "logit"),
    data = Data, na.action = na.pass)

Deviance Residuals:
    Min       1Q   Median       3Q      Max
-3.934e-04 -2.000e-08  2.000e-08  2.000e-08  5.847e-04

Coefficients:
            Estimate Std. Error z value Pr(>|z|)
(Intercept)  4004.700 266688.912   0.015  0.988
INDEPENDENT   -0.386   25.708  -0.015  0.988

(Dispersion parameter for binomial family taken to be 1)

    Null deviance: 2.4155e+02  on 180  degrees of freedom
Residual deviance: 6.5132e-07  on 179  degrees of freedom
AIC: 4

Number of Fisher Scoring iterations: 25

```

**Fig. 5.** The calculation of the dependency of the dependent variable from the independent

A Result has been obtained, according to the results of the calculation that shows remainders and coefficients. Since the calculation of regression [16] is made, we are more interested in the coefficients from which the following picture is seen. The Pr (> | z |) indicator shows whether the coefficients are statistically significant or not.

Since in this case Pr = 0,988 it means that statistical significance exists. This calculation shows that the change in the rate of cryptography with a probability of 98.8% affects the decision to buy / sell cryptocurrency. The buyer during decision making compares and analyzes the cryptos and then he/she chooses cheaper cryptocurrency. So, the change in the price of cryptocurrency with a probability of 98.8% affects the decision to buy / sell cryptocurrency.

But the most important is the value -0,386, it means that in spite of increasing the cost of cryptocurrency of 1 currency unit the value of the logarithm decreases by 0,386 or 3,86%. But actually, these data form are not quite convenient to interpret, it's much more better to make the logarithm to the odds ratio through the exponent:

```

> exp(mylogit$coefficients)
(intercept) INDEPENDENT
Inf          0.679769

```

So, after calculating the exponent, we can say that with the increase of independent variables (price) for 1 currency unit, the ratio of chances of buying a cryptocurrency increases in 0.68 times. The next step of the calculation is to calculate the general level of significance (adequacy) of the model. This action can be done in following way: compare the residual deviation of the model with the deviation of the zero model; calculate the number of degrees of freedom; determine the level of significance correspondingly:

```

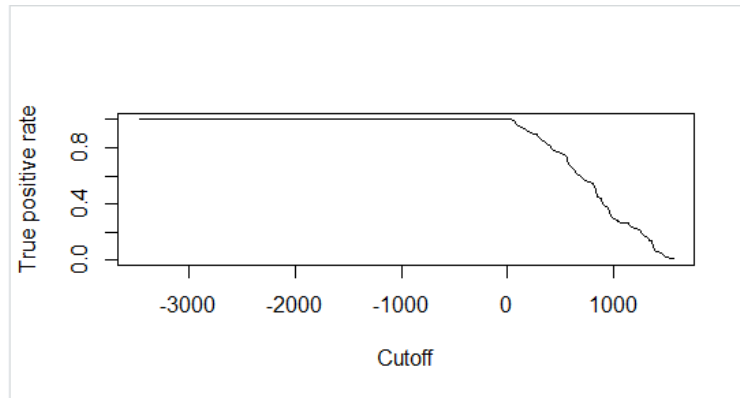
> mylogit$null.deviance-mylogit$deviance
[1]241.5509

```



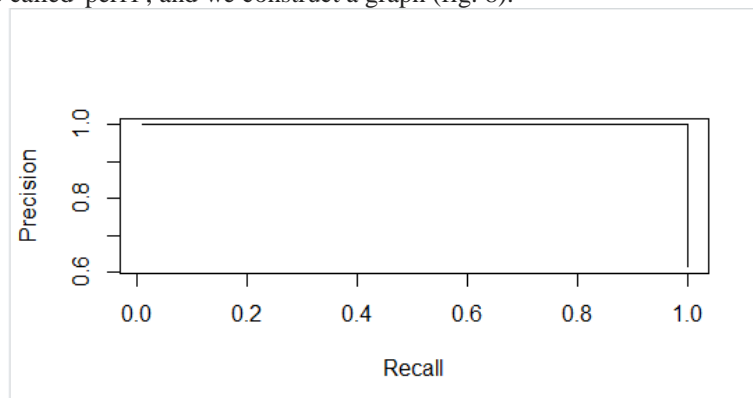


The next step is to construct the 'True positive rate' curve (fig. 7), using previously obtained data.



**Fig. 7.** Graph of the ROC curve

Let's proceed to the calculation of the area under the curve, cause it is more rational and better for future calculations. In order to do this, we would insert an additional change called 'perf1', and we construct a graph (fig. 8).



**Fig. 8.** Graph to calculate the area of the curve

In order to calculate the area under the curve of the graph, we need to use the function 'auc' (Area Under Curve).

```
> auc <- performance(pred, "auc")  
> auc <- unlist(slot(auc, "y.values"))
```

Having completed this calculation, the platform showed the 'auc' = 1 (> auc). It means that ratio of the number of correctly and incorrectly classified attributes to the selected values is perfectly suited.

Having completed the calculations, we have the following general form of the code (fig. 9), and the data (fig. 10).

```

1 Data<-read_xlsx("C:/RStudio/cr.xlsx")
2 View(Data)
3
4 mylogit<-glm(DEPENDENT~INDEPENDENT,Data,family=binomial(link = "logit"),na.action=na.pass)
5 summary(mylogit)
6
7 exp(mylogit$coefficients)
8
9 mylogit$null.deviance-mylogit$deviance
10
11 mylogit$df.null-mylogit$df.residual
12
13 dchisq(mylogit$null.deviance-mylogit$deviance, mylogit$df.null-mylogit$df.residual)
14
15 library(ROCR)
16 a<-predict(mylogit)
17 pred<-prediction(a,Data$DEPENDENT)
18
19 perf<-performance(pred, "tpr")
20 plot(perf)
21
22 perf1<-performance(pred, "prec", "rec")
23 plot(perf1)
24 auc<-performance(pred, "auc")
25 auc<-unlist(slot(auc, "y.values"))
26
27 minauc<-min(round(auc,digits = 2))
28 maxauc<-max(round(auc,digits = 2))
29 minauc<-paste(c("min(AUC)="),minauc,sep = "")
30 minauc<-paste(c("max(AUC)="),maxauc,sep = "")
31 legend(0.2,0.8,c(minauc,maxauc,"\\n"),border = "white",cex = 1.7, box.col = "red")

```

Fig. 9. Completed code

Data	
cr	181 obs. of 3 variables
Data	181 obs. of 3 variables
mylogit	List of 30
perf1	Formal class performance
pred	Formal class prediction
perf	Formal class performance
Values	
a	Named num [1:181] 1404 1244 1162 1162 1152 ...
auc	1
maxauc	1
minauc	"max(AUC)=1"

Fig. 10. Used data during calculations

#### 4 Experiment Evaluation of Investors' Decision

Estimation of probability to be purchased or not for different cryptocurrencies gives us opportunity to develop investment plans [17] for investors with different investment goals and risk attitudes using open dataset ([http://www.di.uniba.it/swap/financialrs\\_data\\_uniba.zip](http://www.di.uniba.it/swap/financialrs_data_uniba.zip)) of investors profiles.

In this case we quantified our ordinal data:

- Risk profile=[very low; low; normal; high; very high]=[1, 2, 3, 4, 5];
- Investment goals=[very low; low; normal; high; very high]=[1, 2, 3, 4, 5],
- Sex=[male, female]=[0, 1].

R tools can process our dataset using principal component analysis (fig. 11) to disclose main types of investors to prepare investment plans for them using financial instruments such as cryptocurrencies [18, 19].

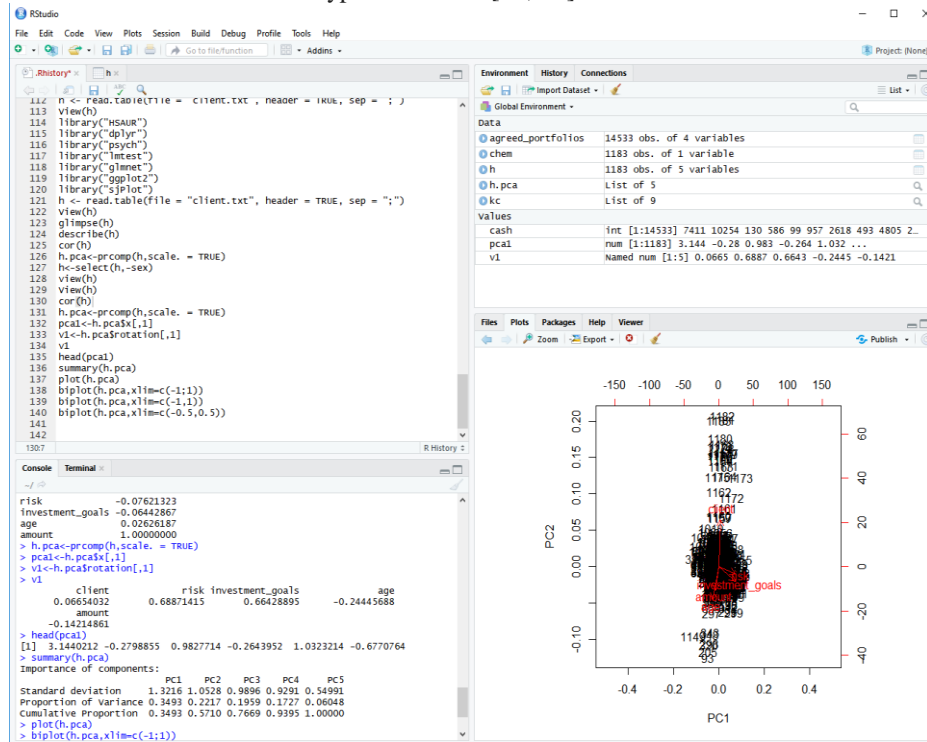


Fig. 11. Visualization of clusters for investors with different attitude to risk

Cluster analysis of estimated data for 14532 investors (fig. 12) revealed 3 types of investors:

- 1<sup>st</sup> type of investor: for the risk-aversing client, who invests in cryptocurrencies, the yield and the risk will be lower.
- 2<sup>nd</sup> type of investor: for the risk-seeking investor, the yield and the risk will be higher.
- 3<sup>rd</sup> type of investor: for neutral type of investor, the yield and risk will be lowest.

Principal component analysis using command biplot reveals that 1<sup>st</sup> main component includes risk (abscissa axis), whereas 2<sup>nd</sup> main component consists of investment goal (ordinate axis). The most investors are risk neutral, second largest group of investors (upper) is risk-averse. The shortest group (below) includes risk-seeking investors.

Thus investors who take part in trading of cryptocurrencies can be potential clients of financial services which construct different investment plans for different risk attitude clients and their behavior after price changing of cryptocurrencies.

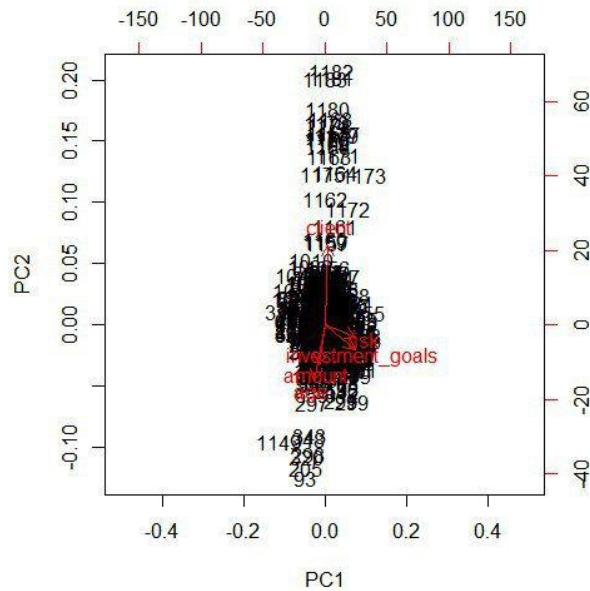


Fig. 12. Clusters analysis for investors with different risk attitude

## 5 Conclusions

As a conclusion of the giving research it is necessary to note that we have found a dependency between the independent variables (the value of the cryptocurrency), and the dependent variables (whether it would be bought or not). The effect of the cryptocurrency rate almost 99% affects the purchase and sale of the currency. 1% describes those buyers for whom the price is not of the great importance, or they have personal preferences, or they are not afraid to take risks. If the price of cryptocurrency increases from its average value, then the chance of the currency to be purchased will be decreased in the inverse proportion.

As a result of simulation experiment through the application using real data from open sources we have revealed that that there were 3 group of investors (especially risk-seeking clients) with different risk attitudes who can invest in different financial instruments such as cryptocurrencies.

## References

1. Ivanov O., Snihovyi O., Kobets V.: Cryptocurrencies Prices Forecasting With Anaconda Tool Using Machine Learning Techniques, Proceedings of the 14th International Conference on ICT in Education, Research and Industrial Applications. Integration,

- Harmonization and Knowledge Transfer, Kyiv, Ukraine, May 14-17 2018, Vol.2105, 453-456 pp.
2. Phillips, R.C., Gorse, D.: Predicting cryptocurrency price bubbles using social media data and epidemic modelling, 2017 IEEE Symposium Series on Computational Intelligence (SSCI), Honolulu, HI, 2017, pp. 1--7.
  3. Colianni, S., Rosales, S.M., Signorotti, M.: Algorithmic Trading of Cryptocurrency Based on Twitter Sentiment Analysis (2015). Mode of access: [http://cs229.stanford.edu/proj2015/029\\_report.pdf](http://cs229.stanford.edu/proj2015/029_report.pdf)
  4. Lamon, C., Nielsen E., Redondo, E.: Cryptocurrency Price Prediction Using News and Social Media Sentiment. *SMU Data Science Review* 1(3), 1--22 (2017).
  5. Kim, Y.B., Kim J.G., Kim W., Im J.H., Kim T.H., Kang S.J., et al.: Predicting Fluctuations in Cryptocurrency Transactions Based on User Comments and Replies. *PLoS ONE* 11(8): e0161197 (2016). <https://doi.org/10.1371/journal.pone.0161197>.
  6. Ziegeldorf, J.H., Matzutt, R., Henze, M.: Secure and anonymous decentralized Bitcoin mixing. *Future generation computer systems-the international journal of escience* 80, 448--466 (2018).
  7. Lahmiri, S., Bekiros, S.: Chaos, randomness and multi-fractality in Bitcoin market. *Chaos solitons & fractals* 106, 28--34 (2018).
  8. Giungato, P., Rana, R., Tarabella, A. et al: Current Trends in Sustainability of Bitcoins and Related Blockchain Technology. *Sustainability* 9(12), 1--11 (2017).
  9. Bariviera, A. F.: The inefficiency of Bitcoin revisited: A dynamic approach. *Economics letters* 161, 1--4 (2017).
  10. Magnus, Y.R., Kagyshev, P.K., Perezetsky, A.A.: *Econometrics. Initial Course: Case.* (2007).
  11. Ayvazyan S.A.: *Applied statistics. Fundamentals of econometrics.* Unity-Dana (2001).
  12. Kaplan R., Urwitz G.: Statistical models of bond ratings: A methodological inquiry. *Journal of Business* 52(2), 231--261 (1979).
  13. Efimova M.: *Workshop on general theory of statistics: tutorial Bachelor's Guide: Yuright* (2013).
  14. Hosmer, D., Lemeshow, S.: *Applied Logistic Regression (2<sup>nd</sup> Edition).* John Wiley & Sons, Inc. (2000).
  15. Moherny V. et al. *Economic Encyclopedia: Publishing Center "Academy"* (2008).
  16. Dowherty K. *Introduction to econometrics. INFRA-M* (2009).
  17. Kobets, V., Poltoratskiy, M. (2016): Using an Evolutionary Algorithm to Improve Investment Strategies for Industries in an Economic System *CEUR Workshop Proceedings*, vol. 1614, P. 485-501 (Indexed by: Sci Verse Scopus, DBLP, Google Scholar). <http://CEUR-WS.org/Vol-1614/ICTERI-2016-CEUR-WS-Volume.pdf>.
  18. Ivanon, O., Snihovyi, O., Kobets, V. (2018): Implementation of Robo-Advisors Tools for Different Risk Attitude Investment Decisions, *CEUR Workshop Proceedings*, vol. 2104, P. 195-206.
  19. Kobets, V., Yatsenko, V., Mazur, A., Zubrii, M. (2018): Data Analysis of Private Investment Decision Making Using Tools of Robo-Advisers in Long-Run Period, *CEUR Work-shop Proceedings*, vol. 2104, P. 144-159. <http://CEUR-WS.org/Vol-2104/>

# Application of Geographic Information Systems in the Field of Domestic Waste Management

Olga Popova<sup>1</sup> [0000-0003-2642-9393], Liubov Pankratova<sup>2</sup> [0000-0002-1403-9454] and  
Inesa Mikhno<sup>3</sup> [0000-0003-3661-1965]

<sup>1</sup> SO “Institute for Economics and Forecasting, UNAS”, 26, Panasa Myrnoho, Kyiv, 01011, Ukraine, olgpomail@gmail.com

<sup>2</sup> National University of Life and Environmental Science, 27 Heroiv Oborony st., Kyiv, 03041Ukraine, pankratova2105@gmail.com

<sup>3</sup> National University of Life and Environmental Science, 27 Heroiv Oborony st., Kyiv, 03022, Ukraine, inessa.mihno@gmail.com

**Abstract.** The algorithm of the application of Google Earth software tools for the processing of satellite data about storage facilities of domestic waste is described. The authorized areas of domestic waste and spontaneous dumps have been identified by number, area and characteristics in the city of Kyiv and in the suburban area. It was found that most dumps are located at a dangerously close distance from residential development, which in some cases exceeds the normative indicators. The authors used the methodical approach in defining the area which is unsuitable for housing development and growing of agricultural crops as well as the area of environmentally destructive influence around the dumps.

**Keywords:** geographic information system, geospatial analysis, tools capabilities, domestic waste, dumps, ecologically destructive influence.

## 1 Introduction

The main problem of waste management in Ukraine is that the predominant amount of domestic waste is utilized by the landfill method, designed to gradually decompose of waste in the natural environment. At the same time, the mass phenomenon is spontaneous garbage dump, which spreads rapidly throughout the area of country.

It is as necessary to identify the placement of authorized landfills for storage of municipal solid waste (MSW) on the territory as unauthorized dumps, to identify its actual characteristics, to define the actual area of its ecologically destructive influence on the residence of the population and agricultural land. The use of modern geographic information systems (GIS) allows conducting such identification and evaluation.

It is important to build an algorithm for the detection of garbage landfills and dumps with application of GIS tools capabilities and to evaluate the data obtained to substantiate offers of the waste management in the country.

## 2 Theoretical and Methodological Backgrounds

Nowadays GIS are widely used in different fields. There are many definitions for a geographic information system. The most famous definition of Aronoff, S. (1989): A GIS is a computer-based system that provides the following four sets of capabilities to handle geo-referenced data:

1. input,
2. data management (data storage and retrieval),
3. manipulation and analysis, and
4. output [1].

Y. Shokin and V. Potapov (2015) compared many definitions of GIS in scientific literature and described GIS as an information system that provides for the collection, storage and analysis of spatial information, that is, as a geographic information service [2].

The first developments of the virtual digital platform for Earth monitoring, known as Google Earth today, appeared in 1998. The methods which are used to develop algorithms for this platform have become typical in the development of other geographic information systems.

Today, separate GIS and based on integrated GIS electronic atlases are used for:

- monitoring of the state of land use and the assessment of the condition of agricultural lands;
- cadastral accounting of land, water, resources, as well as resources of forestry and mineral deposits;
- assessing the status of garbage landfills and detecting unauthorized dumps;
- studying and evaluating biodiversity and ecological status of the territories;
- detection of emergency situations (oil spill, fires, flooding, etc.).

Modern researchers have expanded the scope of GIS. In particular, N. Sianko and M. Small (2017), T. VoPham (2018) argue that geospatial data are useful in solving problems associated with demography, population migration and health. T. Paientko (2018) in her work shows the possibilities of using GIS in the development of reforms in the field of public finance [5]. W. Zhou (2018) demonstrates applications of GIS and remote sensing in landslide hazard assessment.

The use of geospatial data has a number of undeniable advantages, the main of which is that these data are available for free general use, as noted by H. Niska and A. Serkkola [7].

The constant growths of living standards in the world and the changes in consumer goods have negative externalities, and H.W. Gottinger (2018) highlights the problem of waste accumulation as one of them. It is important to respond in a timely manner to the negative consequences of waste management, to identify areas of unauthorized dumps. J.F. Salsa and J.L. Gallego (2018) emphasize the need to introduce monitoring systems for the main places of its accumulation in dynamics. As T. Matsuda and Y. Hirai (2018) confirm, monitoring the dynamics of waste quantity and its structure are an effective method in developing scenarios to cover its negative effects. Correct structuring of waste components can greatly facilitate its processing and reduce expenditures of its utilization.

O. Trofymchuk and V. Trysnyuk (2014) combines the methods of remote sensing of the Earth and GIS for inventory of waste disposal area with methods of mathematical modeling and emphasize its importance for the comprehensive study of sources of influence and ultimately for making well-considered decisions in improving the environmental situation in the natural-technological system [11].

Accumulation of significant volumes of data contributes to the development of the intellectual analysis of geospatial data, which is provided on the basis of information about the geospatial locations of objects in local and global systems of coordinates and have a certain number of regularities and dependencies in large databases. Analytical capabilities of modern instrumental geographic information systems are quite diverse. There is the mention by R.N. Clark and G.A. Swayze (2003) that several dozens of different analytical procedures consist of package of blocks with advanced analytical capabilities (packages ARC/INFO, IDRISI, MGE, PCRaster), arise from a possible simple time analysis and modeling. It should be noted that implemented in different GIS packages analytical procedures have close components. It allows considering the method of GIS analysis, which is the main information potential, without taking into account specifics of GIS packages [13].

First of all, it is necessary in the study to select certain objects in space, in order to limit the scope of research, using the functions of data selection. Such allocations can be made spatially or on the basis of attribute data which are related to spatial objects. The method of data selection is a request of spatial choice. These requests can be combined or executed in a certain sequence to obtain the final result.

Google Earth is a project of Google company that provides satellite imagery (or, in some cases, aerial photos) over the entire terrestrial surface on the Internet. According to N. Gorelick and M. Hancher (2017) photos of some regions have an unprecedentedly high resolution of images. Virtually the entire surface of the land is covered by images which are obtained from Digital Globe and have a resolution of 15 m per pixel. Separate surface areas (capitals and some large cities) have even more detailed permission. Data of terrain elevations have a clearance of about 90 m (about 30 m in the US) horizontally and vertical accuracy – up to one meter.

Google Earth uses Keyhole Markup Language (KML) markup languages to represent geospatial data. A KML file can contain (in the URL form) links to other KML or KMZ files (KML file extensions) which are hosted on the network. It is possible to specify conditions, the regularity of loading and displaying data from these sources [15]. Objects inside the KML file can be organized in hierarchical structures of folders and subfolders in order to easy share or disable images of logically interrelated groups of objects.

Google Earth has a large arsenal of layers, there is the ability to manually select data to display, there are labels (marker and polygon) and various tools for processing satellite data.

The authors have developed a methodological approach to define the area of intense pollution that is unsuitable for normal use (housing development and growing of agricultural crops) due to the significant ecologically destructive influence of dumps. For this purpose, it was used standards of State Construction Norms (SCN) V.2.4-2-2005 "Polygons of municipal solid wastes: main provisions of design" (2015), which



states that the distance from residential and public building (sanitary protection zone) should be 500 m, from agricultural land – 200 m. For calculations, the distance indicator from the MSW landfill is 500 m. Although, in our opinion, this distance is not sufficient for the comfortable residence of the population, especially with increasing volumes of the MSW landfill outside.

To simplify the calculations, it was assumed that the area of the polygon in the form of a circle. Authors' formulas were used, which are based on the calculations of the circle area, where the radius is the sum of the radius of the landfill MSW and the radius of the zone of its influence.

The total area of the sanitary protection zone around the MSW landfill (including the MSW landfill) can be calculated by the formula:

$$S_{spz} = \pi * \left( \sqrt{\frac{A}{\pi}} + 500 \right)^2 \quad (1)$$

where,

$S_{spz}$  – area of the sanitary protection zone ( $m^2$ );

$A$  – area of the MSW landfill ( $m^2$ );

$\sqrt{\frac{A}{\pi}}$  – the radius of the MSW landfill area in the form of a circle ( $m$ );

500 – the radius of the sanitary protection zone ( $m$ ).

It should be noted that similar dimensions of sanitary protection zone are installed in Turkey and Greece – it is also 500 m, in Serbia is 1 km and in UK is 2 km.

Zone of ecologically destructive influence of dumps on the residence of the population is zone within which the inhabitants of the surrounding settlements experience considerable discomfort due to the unfavorable state of the atmospheric air (evaporation and stink) and water resources (unsuitability for drinking), and so it has influence on their state of health. In our calculations we used standards of SCN V.2.4-2-2005 "Polygons of municipal solid wastes: main provisions of design" (2015), which defined that the distance between the MSW landfill and limits of the resort town, open water reservoirs, reserves, resting places of migratory birds, sea coast should be 3000 m. In addition, according to the results of surveys which were conducted by us inhabitants of villages near MSW landfills, outside the distance of 3000 m complaints about the adverse influence and consequences are reducing (Fig.1).

The total area of ecologically destructive influence zone of MSW landfill (including the MSW landfill) is defined by the formula:

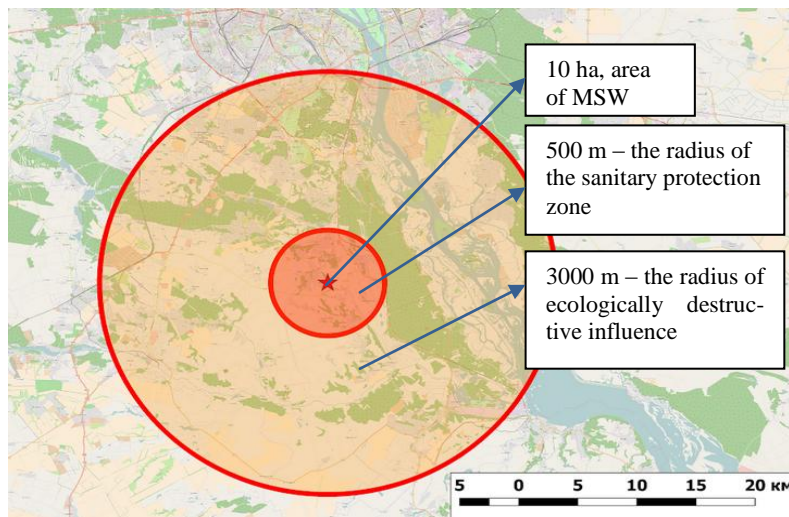
$$S_{ediz} = \pi * \left( \sqrt{\frac{A}{\pi}} + 3000 \right)^2 \quad (2)$$

where,

$S_{ediz}$  – area of ecologically destructive influence zone ( $m^2$ );

$A$  – area of the MSW landfill ( $m^2$ );

$\sqrt{\frac{A}{\pi}}$  – the radius of the MSF landfill area in the form of a circle( $m$ );  
 3000 – the radius of ecologically destructive influence ( $m$ ).



**Fig. 1.** Scheme of zone of intense pollution and zone of ecologically destructive pollution around MSW landfill.

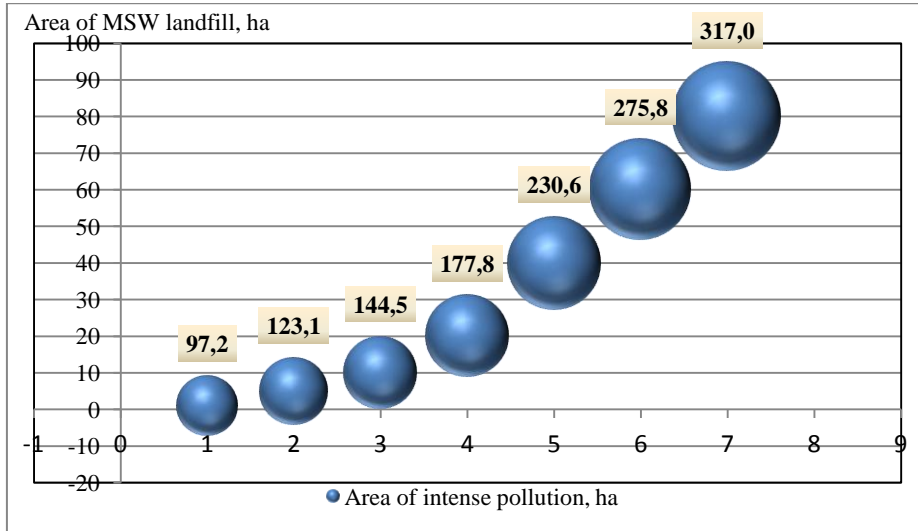
Authors offer to define efficiency of utilization of domestic waste by its processing with the help of increase in the function of public welfare.

### 3 Identification of Dumps and Its Real Parameters with Use of GIS

#### 3.1 Case study of garbage polygons, calculation of sanitary protection zones and zones of ecologically destructive influence

The fire at MSW landfill in Lviv city demonstrated that Ukraine is on the edge of an ecological catastrophe due to improper utilization of domestic waste. According to official statistics for 2014-2017, there are 296-366 million tons of waste is produced each year in Ukraine, by the end of 2017 more than 12.4 billion tons of waste has been accumulated in specially designated places for its disposal [17].

According to the calculations of zone of intense pollution (sanitary protection zone) with standard distance of 500 m (according to formula 1), MSW landfill with an area of 1 hectare (ha) leads to unsuitability of 98 ha of land for the residence of the population and cultivation of agricultural crops, while landfill with an area of 10 he transforms to the exclusion zone – 144.5 ha, etc. (Fig. 2).



**Fig. 2.** The dynamics of the expansion of the area of intense pollution, depending on the area of MSW landfill, ha

According to calculations of zone of ecologically destructive influence with a defined distance of 3000 m (according to formula 2), MSW landfill with an area of 1 ha leads to unfavorable conditions for residence of population and decrease in the quality of cultivated agricultural products on 2933.3 ha of land. For the size of a landfill of 10 ha, this area is growing to 3172.2 ha, etc.

Definition of the area of ecologically destructive influence of MSW landfill and the need for its legislative regulation, along with the currently established only sanitary protection zone, is important, including for the compensation (material or otherwise) for residents of the surrounding settlements. This tool will become more and more important taking into account organized protests of residents against dumps near their settlements.

It was used the tools capabilities of geospatial analysis with the help of Google Earth service for the identification of dumps (including unauthorized ones) and its characteristics on the territory of Kyiv city and in the suburban area.

The "Placemark" tool is used to select and save data about the user-selected place on the map. There are several types of marks in Google Earth, which are dot markers in the form of a marker that has only one coordinate point and polygons with a certain number of coordinate points on the plane. The polygon mark serves to highlight an arbitrary shape object. Since the places of domestic waste storage occupy different size of areas, location of garbage landfills and dumps were highlighted with the help of the polygon mark (Fig. 3 and 4). The detected garbage landfills in Kyiv city and the adjacent 20-kilometer area in the amount of 30 units are saved on the local disk as marks.

Further processing of the data involved the insertion of a shape-file into the QGIS software environment (QuantumGIS – a free cross-platform geographic information system) for transforming from a vector layer to a raster (rasterization). The preliminary steps are required to perform the sample, which involves segmentation (clustering) and classification (grouping) of satellite imagery.

According to the Google Earth software, the following characteristics of MSW landfills and dumps on the territory are investigated: perimeter and area of the landfill or dump, changes which occur in the dynamics (for a certain period of time), perimeter and area of ecological destructive influence, distances to residential buildings and agricultural land.

According to data of satellite (a fragment of the satellite map is depicted in Fig. 3), it is defined that the actual area of MSW landfill № 5 in Pidhirtsi village, Obukhiv district, Kyiv region is 80 ha, while officially documented only 63.7 ha [18].

The distance from the landfill to the residential zone is 450 m and to the cultivated agricultural land is 700 m.

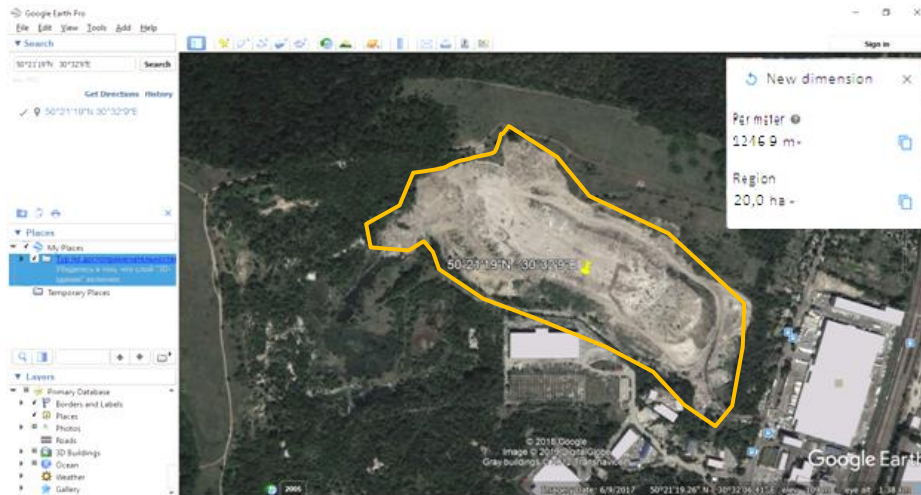


**Fig. 3.** Cartographic image of MSW landfill № 5 in Pidhirtsi village of the Kyiv region

Our calculations according to the formula (1) show that the total area of unsuitable for agricultural use and the residence of population is 317 ha. The area of ecologically destructive influence of landfill on the residence of population and agricultural land is 3857.0 ha.

Similar researches on the construction waste landfill № 6 showed that it is located within the city of Kyiv in the Holsiivskyi district not far from residential micro districts and has an area of about 20 ha according to the satellite (Fig. 4), while according to official documents is 11.6 hectares [18].

It is established that the waste have significant part of domestic garbage that is not specified in the operational documents. Domestic waste and scrap metal continues to deliver to landfill. The active use of the polygon illustrates the dynamics of growth of garbage and changes in its surface. However, there are no waste utilization and aeration systems. The area near the landfill is an industrial zone and is guarded.



**Fig. 4.** Cartographic image of landfill of construction waste № 6 in Kyiv city

It should be noted that slightly distant of landfill № 6 to residential districts is only 200 m (while this distance for landfills with domestic waste should be at least 500 m according to state design standards and to the city is 1 km). Taking into account the significant share of domestic waste at the landfill, the total area of unsuitable for agricultural use and residence of the population is, according to our estimates, is 177.8 ha.

Taking into account the negative influence of the polygon on the ecosystem, the conditions in the surrounding areas like the village Korchuvate, the National Museum of Folk Architecture and the open-air "Pirogovo" and other neighbor districts are unfavorable for residence and for rest of population. The ecologically destructive influence of this large storage landfill of construction and other wastes extends to the whole Holiivskyi district, which is not only densely populated, but also due to the location of the Holiivskyi Park and the wide forest with lakes, the Natural Park of Feofania, the National Exhibition Center, a number of religious shrines, is an attractive place for the rest Kyiv citizens and guests of the capital. In addition, this area is widely positioned as an ecologically clean area. Therefore, the landfill № 6 does not contribute to the confirmation of the eco-image of this district.

It is annually formed about 1.7 million tons of waste of I-IV classes of danger in Kyiv, from which 258.6 thousand tons are burned, that is, only about 16%, the rest is accumulated in specially designated places for storage, that is, at the landfills [17].

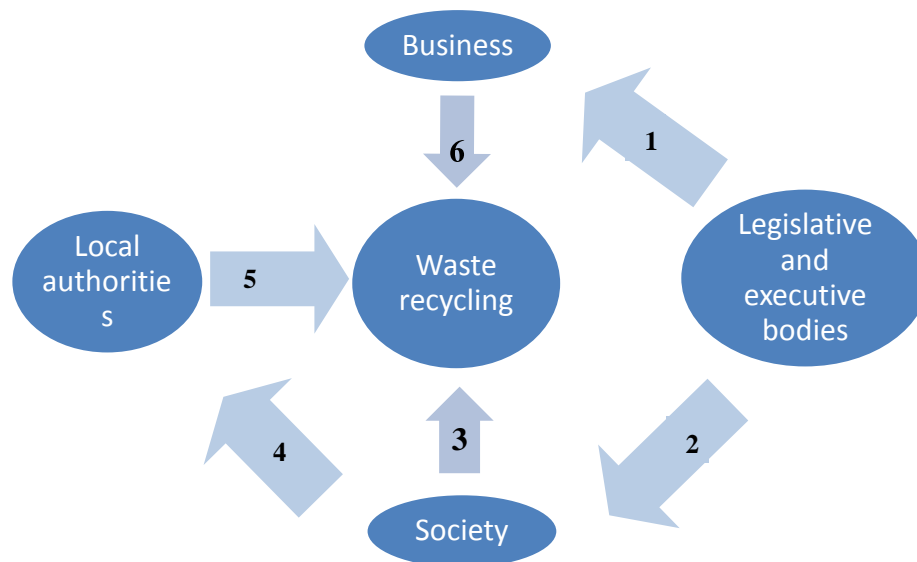
According to satellite data, 30 landfills and dumps in Kyiv city and at a distance of 20 km from the city cover an area of over 160 ha. According to our calculations (formula 1), the area of intense pollution around landfills is 462.6 ha, and the area of ecologically destructive pollution is 4330.8 ha. It is obvious that low-yielding, unsuitable for agrarian use land were allocated under the garbage landfills, but the negative influence of these landfills and spontaneous landfills extends to adjoining cultivated agricultural lands and areas of population residence.

### 3.2. Participation of stakeholders and its functions in the processing of domestic waste

The prevalence of waste storage/disposal in Ukraine doesn't accord to European practice and doesn't approve by international community according requirements for proper waste management. In particular, European Union strive to process over 20% of plastic by 2030, and to make all packaging plastics easily processed (currently 65% are processed) or reused.

For a long time, the task of waste management in the country is urgent. According to this aim, it is necessary to develop and purposefully implement the relevant organizational and economic mechanism, with the involvement of GIS data and a defined sequence of actions of so subjects as waste producers and other stakeholders.

A wide range of stakeholders should be involved in setting up the garbage processing with their functional responsibilities ( Fig. 5).



*Designation in the scheme:*

1. Introduction of the land market, the abolition of VAT on the import of garbage processing technologies, the abolition of the profit tax for garbage processing enterprises
2. Informing the public about the state of the environment using GIS, introducing penalties for non-sorting of domestic waste
3. Garbage sorting
4. Public control over the activities of local authorities, definition of characteristics of enterprises for the processing of garbage
5. Allocation of areas for storage and garbage processing on the basis of GIS observations
6. Investing in garbage processing

**Fig. 5.** Participation of stakeholders in the garbage processing

The following sequence of actions for improvement of domestic waste processing is offered:

1) A media advocacy company (television, radio, internet) which explains the benefits of waste sorting and waste management options. At the same time, it is important to demonstrate clearly the data of satellite observations about the danger of dumps near the cities and villages for the life of its inhabitants and for the quality of agricultural land;

2) Implementation of ecological tax for the population;

3) The combination of both of the above measures (i.e., a part of society will sort domestic waste in accordance with the established procedure, and the other – will pay penalties at sufficient quantity for the cost of sorting garbage).

Since Kyiv, due to the large number of citizens, higher levels of their income and consumption, produces a large amount of garbage per person, then it is advisable to start implementation of sorting system and further processing of domestic waste exactly in this city. It is necessary to build a modern complex of waste processing which will be based on recycling. As experience of European countries shows, the average level of profitability of MSW utilization plants is at the level of 3%. Other settlements will support the initiative to organize the sorting and processing of waste if the company is successful.

The components of the growth function of the public welfare from the implementation of the recycling and investment system in the processing of waste can be calculated by the formula:

$$\Delta W = \Delta W_1 + \Delta W_2 + \Delta W_3 + \Delta W_4, \quad (3)$$

where,

$\Delta W_1$  – improvement of the health of the population due to improvement of environment;

$\Delta W_2$  – increase due to the production of qualified agricultural products from territories without influence of dumps because of taken actions;

$\Delta W_3$  – the cost of raw materials which are produced by waste processing enterprises;

$\Delta W_4$  – increase of employment

Offered components for calculating the growth function of the public welfare are readily quantified and reflect the bulk of the effect of society on the establishment of system for processing of domestic waste.

The efficiency of utilization of waste by processing it from the standpoint of public welfare is equal to:

$$E_{w/s} = \frac{\Delta W}{\Delta S}, \quad (4)$$

where,

$\Delta W$  – growth function of the public welfare;

$\Delta S$  – increase of expenses for waste processing.

Increase of expenses in the case of utilization of waste by proper processing is equal to the sum of components:

$$\Delta S = \Delta S_1 + \Delta S_2 + \Delta S_3 + \Delta S_4 \quad (5)$$

where,

$\Delta S_1$  – increase of time expense by population for waste sorting (monetary equivalent);

$\Delta S_2$  – conducting a company to inform the mass media about advantages to introduce garbage utilization by its processing;

$\Delta S_3$  – additional technique expenses;

$\Delta S_4$  – investments in garbage processing (the acquisition of equipment and technology).

According to the current prevailing practice of waste storage, growth function of public welfare is negative: the state of environment, the health status of inhabitants of villages and cities in the places of the location of garbage landfills deteriorates; areas where high-quality agrarian products can be produced are reducing.

For example, according to calculations, investing of garbage processing is \$ 1 million that leads to growth function of the public welfare only at the expense of growing volumes of agricultural production by 4.4 million dollars [19]. Such effect can be received from one component of the public welfare function due to investing of waste processing. Calculations of growth function of the public welfare for other mentioned components are the subject of further research of the authors.

## 4 Conclusions

Modern tools of geographic information systems, and in particular the Google Earth software, provide opportunities for identifying official waste landfills and spontaneous dumps, identifying its characteristics and defining the territory of ecologically destructive influence.

Using the Google Earth tools capabilities, it was formed the information base of the identified 30 official waste landfills and spontaneous dumps on the territory of Kyiv and in the 20-kilometer suburban area. Its actual area (total 160 ha), the distance to residential buildings and the dynamics of changes have been identified. Relying on its own methodological approach, it is defined that the area of intense pollution around dumps that is unsuitable for residence development and growing of crops within the boundaries of Kyiv and the suburbs is in 2.9 times bigger the area of dumps, and the area of its ecologically destructive influence on the environment and residence of the population is in 27 times.

According to cartographic images from the satellite it was exceeded that the actual area of waste landfills and dumps is above the documented area.

Geospatial systems and geospatial analysis should be widely used in many spheres of life. Using it, the authors formed an information base about available official MSW landfills and spontaneous dumps and its actual characteristics. This research material



demonstrates and proves the importance of changes in the field of waste management in Ukraine, namely, transition from the storage of domestic waste to its processing.

## References

1. Aronoff S.: Geographic information systems: A management perspective. *Geocarto International*. 4(4), 58-58 (1989). doi: 10.1080/10106048909354237
2. Shokin Y.I., Potapov V.P.: GIS today: state, perspectives, solutions. *Computational technologies*, 20(5), 175-213 (2015).
3. Sianko, N., Small, M.: The future of GIS in social sciences. *Kontakt* 19(3), e157-e158 (2017). doi: 10.1016/j.kontakt.2017.08.001
4. VoPham, T.: GIS&T and Epidemiology. *Geographic Information Science & Technology Body Of Knowledge*, 2018(Q1), (2018). doi: 10.22224/gistbok/2018.1.1
5. Paientko T. Geographic Information Systems: Should They Be Used in Public Finance Reform Development? *CEUR Workshop Proceedings*, vol. 2104, 233-242 (2018) (Indexed by: Sci Verse Scopus, DBLP, Google Scholar). Available: <http://ceur-ws.org/Vol-2104/>
6. Zhou, W.: Applications of GIS and remote sensing in landslide hazard assessment. *Journal Of Remote Sensing & GIS*, 07 (2018). doi: 10.4172/2469-4134-c1-010
7. Niska, H., Serkkola, A.: Data analytics approach to create waste generation profiles for waste management and collection. *Waste Management*, 77, 477-485 (2018). doi: 10.1016/j.wasman.2018.04.033
8. Gottinger, H. W.: *Economic models and applications of solid waste management*. Routledge (2018).
9. Saldarriaga, J.F., Gallego, J.L., López, J.E. et al: *Waste Biomass Valor* (2018). <https://doi.org/10.1007/s12649-018-0208-y>
10. Matsuda, T., Hirai, Y., Asari, M., Yano, J., Miura, T., Ii, R. Sakai, S.I.: Monitoring environmental burden reduction from household waste prevention. *Waste Management*. 71, 2-9 (2018). doi: 10.1016/j.wasman.2017.10.014
11. Trysnyuk, V., Novokhatska, N., & Radchuk, I.: Geo-information Technologies for Decision Issues of Municipal Solid Waste. *Journal of Environmental Science and Engineering*. A 3 (3A) (2014.)
12. Clark, R.N., Swayze, G.A., Livo, K.E., Kokaly, R.F., Sutley, S.J., Dalton, J.B., McDougal, R.R., Gent, C.A.: Imaging spectroscopy: Earth and planetary remote sensing with the USGS Tetracorder and expert systems. *Journal of Geophysical Research-Planets*, 108 (E12) (2003).
13. Domanska M.V., Bodnar S.P.: Identification of unauthorized dumps due to data of remote sensing. *Cartography magazine* 7, 114-126 (2013).
14. Gorelick, N., Hancher, M., Dixon, M., Ilyushchenko, S., Thau, D., Moore, R. : Google Earth Engine: Planetary-scale geospatial analysis for everyone. *Remote Sensing of Environment*, 202, 18-27 (2017). <https://doi.org/10.1016/j.rse.2017.06.031>
15. Keyhole Markup Language. Google Developers. (2019). Retrieved from <https://developers.google.com/kml/>
16. SCN V.2.4-2-2005 "Polygons of municipal solid wastes: main provisions of design" (2015). Retrieved from [http://media.voog.com/0000/0036/1658/files/%D0%94%D0%91%D0%9D\\_%D0%92.2.4\\_2-2005.pdf](http://media.voog.com/0000/0036/1658/files/%D0%94%D0%91%D0%9D_%D0%92.2.4_2-2005.pdf)
17. State Statistics Service of Ukraine (2019). Retrieved from <http://www.ukrstat.gov.ua/>

18. Ministry of Regional Development, Construction and Housing and Communal Services of Ukraine (2019). Retrieved from <http://www.minregion.gov.ua/>
19. Skripnik, A. V., Mihno, I. S.: Domestic waste management from the standpoint of public welfare. *Problemy Ekonomiky*, 3 81-88 (2016).

# Forecasting of Cereal Crop Harvest on the Basis of an Extrapolation Canonical Model of a Vector Random Sequence

Igor Atamanyuk<sup>1</sup>, Yuriy Kondratenko<sup>2</sup>, Anastasiya Poltorak<sup>1</sup>, Natalia Sirenko<sup>1</sup>, Vyacheslav Shebanin<sup>1</sup>, Inna Baryshevska<sup>1</sup>, Valeriia Atamaniuk<sup>3</sup>

<sup>1</sup> Mykolayiv National Agrarian University, Georgiya Gongadze Str. 9, 54010 Mykolaiv, Ukraine  
atamanyuk@mnau.edu.ua, sirenko@mnau.edu.ua, shebanin@mnau.edu.ua, BaryshevskaIV@mnau.edu.ua, poltorak@mnau.edu.ua

<sup>2</sup> Petro Mohyla Black Sea National University, 68th Desantnykiv Str. 10, 54003 Mykolaiv, Ukraine  
y\_kondrat2002@yahoo.com

<sup>3</sup> Western Norway University of Applied Sciences, Bjørnsons Str. 45, 5528 Haugesund, Norway  
atamanyuk.le@gmail.com

**Abstract.** The work is devoted to the solving of an important economic problem of the forecasting of cereal crop harvest. A stochastic character of the change of crop yield figures because of the influence of random weather-related factors is an essential peculiarity of this problem. Therefore, to forecast the cereal crop harvest, the methods of random sequence analysis are proposed to use. The developed extrapolation method doesn't impose any restrictions on a forecasted random sequence of the change of crop yield figures (linearity, stationarity, Markov behavior, monotony, etc.). Taking into full account stochastic peculiarities of the conditions of cereal crop production and crop yield figures allows to achieve maximum accuracy of a forecasting problem solving. The block diagram of an algorithm introduced in the work represents the peculiarities of the calculation of the predictive model parameters. The expression for calculation of an extrapolation error allows to determine necessary volume of a priori and a posteriori information for achieving required quality of a forecasting problem solving. The results of a numerical experiment confirmed high efficiency of the suggested method of forecasting of the cereal crop harvest.

**Keywords:** calculation method, random sequence, canonical decomposition, prognostication of the crop.

## 1 Introduction

Volume of grain production essentially influences standards of living, contributes to food security of a country. Crop capacity deserves special attention among many figures characterizing the level of cereal crops production. Solving of the problems of formation of food reserve funds, availability of necessary facilities for storing of obtained harvest, forming of adequate and efficient foreign trade policy greatly depend on the accuracy of its forecasting. The actuality of crop yield forecasting gets special importance when developing management decisions under conditions of uncertainty including the conditions of economic instability. In the light of the issues of food security, the problem of crop yield forecasting is actual not only for Ukraine as one of the biggest grain producers but also for international community [1,2].

Crop productivity is a complex figure from the point of view of the forecasting because harvest formation is connected with the influence of both production factors and weather conditions and also greatly depends on the peculiarities of biological systems [2].

At present different approaches to the crop yield forecasting are developed and applied in practice on the basis of:

- 1) analysis of trend and cyclicity in the crop yield dynamics [3,4];
- 2) identification of the analogous year [5];
- 3) forming of regression dependencies between different statistical data and data obtained on the basis of remote and meteorological observations [4];
- 4) modeling [4,6];
- 5) analysis of synoptic processes [7].

Approaches of the first, second and fifth groups distinguish with great lead time as well as with insufficient accuracy. The approaches of the third and the fourth groups are most widely used. In most cases meteorological data are used as input information for building regression or for the modeling of the processes of plant growth. In these cases the forecasting is based mostly on the use of indirect factors, not on the analysis of the actual state of soil and peculiarities of the use of fertilizers for plant nutrition and soil fertility improvement.

Dynamic models [4] used today don't take into account the whole background of the change of crop yield figures and conditions of cereal crop production which significantly restricts the accuracy of such models.

A main peculiarity of crop capacity is a stochastic character of the change of this figure. Thereupon, to forecast the cereal crop harvest for the purpose of maximum use of the production background and to take into a full account the influence of different random factors (amount of precipitation, air and soil temperature, number of sunny days, humidity, etc.), it is necessary to use the methods and algorithms of the theory of random functions and random sequences.

The aim of this work is the development of the efficient and robust method for forecasting of the cereal crop harvest. The main requirement to the forecasting method is the absence of any essential limitations on the stochastic properties of the accidental process of change of the cereal crop harvest.

## 2 Related Works and Problem Statement

Methods of artificial intelligence that are used for the forecasting of random sequences have restricted accuracy characteristics and are applied as a rule in case of small volume of statistic data [8,9]. When analysing the cereal crop harvest, quite large volume of information can be accumulated at expense of increasing of data detailing (figure concretization at the regional level and agricultural enterprises; monthly accounting for temperature, moisture, quantity of fertilizers; use of soil characteristics, etc.). Therefore, to formulate mathematical models, it is expedient to apply deductive methods of forecasting on the basis of maximum volume of a priori information. Kolmogorov-Gabor polynomial [10] is the most general extrapolation form to solve the problem of non-linear extrapolation, but determination of its parameters for a large number of known values and used order of non-linear relations is a very difficult and laborious procedure (thus, for 11 known values and 4th order nonlinearity, it is necessary to obtain and solve 1819 equations of partial derivatives of mean-square error of extrapolation). Thereupon, when forming realizable in practice algorithms of the forecasting, different simplifications and restrictions on the properties of a random sequence are used. For example, a number of suboptimal methods [11] of non-linear extrapolation with a bounded order of a stochastic relation on the basis of approximation of a posteriori density of probabilities of an estimated vector by orthogonal Hermite polynomial expansion or in the form of Edgeworth series is offered by V.S. Pugachev. The solution of non-stationary A. N. Kolmogorov equation (a particular case of R. L. Stratanovich differential equation [12] for description of Markovian processes) is obtained provided that a drift coefficient is a linear function of the state, and a diffusion coefficient equals to a constant. An exhaustive solution of the problem of optimal linear extrapolation for different classes of random sequences and different level of informational support of a forecasting problem exists (A.N. Kolmogorov equation for stationary random sequences measured without errors; Kalman method [13] for Markov noisy random sequences; Wiener-Hopf filter-extrapolator [14] for noisy stationary sequences; algorithms of optimal linear extrapolation of V.D. Kudritsky [15] on the basis of linear canonical expansion of V.S. Pugachev, etc.). However, maximum accuracy of the forecasting with the help of the methods of linear extrapolation can be achieved only for Gaussian random sequences. Forecasting method [16,17] on the basis of non-linear canonical expansion is the most universal with regard to limitations (linearity, Markov property, stationarity, monotony, scalarity, etc.) imposed on the properties of the sequences of random values. Application of this method will allow to take full account of peculiarities of the change of cereal crop harvest and, consequently, to achieve maximum quality of forecasting.

## 3 Theoretical Conception of the Proposed Forecasting Method

Vector random sequence  $\overline{X}(i) = \{X_n(i)\}$ ,  $i = \overline{1, I}$ ,  $h = \overline{1, H}$  is to be considered. Components are random sequences describing the change of the crop yield figures of cer-

tain cereal crops (wheat, rye, barley, etc.), the change of natural conditions (temperature, precipitation amount, number of sunny days, etc.) and also intensity of the use of mineral and organic fertilizers at discrete points of time  $t(i)$  (as a rule with discrete step which is equal to one year for mesoeconomic and macroeconomic forecasting).

Non-linear canonical expansion of a vector random sequence can be written as [18,19]:

$$X_h(i) = M[X_h(i)] + \sum_{\nu=1}^{i-1} \sum_{l=1}^H \sum_{\lambda=1}^N W_{\nu l}^{(\lambda)} \beta_{l\lambda}^{(h,1)}(\nu, i) + \sum_{l=1}^{h-1} \sum_{\lambda=1}^N W_{il}^{(\lambda)} \beta_{l\lambda}^{(h,1)}(i, i) + W_{ih}^{(1)}, \quad i = \overline{1, I}. \quad (1)$$

Discretized moment functions  $M[X_l^\lambda(\nu)]$ ,  $M[X_l^\lambda(\nu)X_h^s(i)]$ ,  $\nu, i = \overline{1, I}$ ;  $l, h = \overline{1, H}$ ;  $\lambda, s = \overline{1, N}$  are source information for the model of a random sequence.

Random coefficients  $D_{l,\lambda}(\nu)$ ,  $l = \overline{1, H}$ ,  $\lambda = \overline{1, N}$ ,  $\nu = \overline{1, I}$  and non-random coordinate functions,  $\beta_{l\lambda}^{(h,s)}(\nu, i)$ ,  $l, h = \overline{1, H}$ ,  $\lambda, s = \overline{1, N}$ ,  $\nu, i = \overline{1, I}$  are determined with the help of following expressions (algorithm of parameter calculation is presented in Fig.1):

$$W_{\nu l}^{(\lambda)} = X_l^\lambda(\nu) - M[X_l^\lambda(\nu)] - \sum_{\mu=1}^{\nu-1} \sum_{m=1}^H \sum_{j=1}^N W_{\mu m}^{(j)} \beta_{mj}^{(l,\lambda)}(\mu, \nu) - \sum_{m=1}^{l-1} \sum_{j=1}^N W_{\nu m}^{(j)} \beta_{mj}^{(l,\lambda)}(\nu, \nu) - \sum_{j=1}^{\lambda-1} W_{\nu l}^{(j)} \beta_{lj}^{(l,\lambda)}(\nu, \nu), \quad \nu = \overline{1, I}; \quad (2)$$

$$D_{l,\lambda}(\nu) = M\left[\left\{W_{\nu l}^{(\lambda)}\right\}^2\right] = M[X_l^{2\lambda}(\nu)] - M^2[X_l^\lambda(\nu)] - \sum_{\mu=1}^{\nu-1} \sum_{m=1}^H \sum_{j=1}^N D_{mj}(\mu) \left\{\beta_{mj}^{(l,\lambda)}(\mu, \nu)\right\}^2 - \sum_{m=1}^{l-1} \sum_{j=1}^N D_{mj}(\nu) \left\{\beta_{mj}^{(l,\lambda)}(\nu, \nu)\right\}^2 - \sum_{j=1}^{\lambda-1} D_{lj}(\nu) \left\{\beta_{lj}^{(l,\lambda)}(\nu, \nu)\right\}^2, \quad \nu = \overline{1, I}; \quad (3)$$

$$\beta_{l\lambda}^{(h,s)}(\nu, i) = \frac{M\left[W_{\nu l}^{(\lambda)}\left(X_h^s(i) - M[X_h^s(i)]\right)\right]}{M\left[\left\{W_{\nu l}^{(\lambda)}\right\}^2\right]} = \frac{1}{D_{l\lambda}(\nu)} \left(M\left[X_l^\lambda(\nu)X_h^s(i)\right] - M\left[X_l^\lambda(\nu)\right]M\left[X_h^s(i)\right]\right) - \quad (4)$$

$$\begin{aligned}
& - \sum_{\mu=1}^{v-1} \sum_{m=1}^H \sum_{j=1}^N D_{mj}(\mu) \beta_{mj}^{(l,\lambda)}(\mu, v) \beta_{mj}^{(h,s)}(\mu, i) - \\
& - \sum_{m=1}^{l-1} \sum_{j=1}^N D_{mj}(v) \beta_{mj}^{(l,\lambda)}(v, v) \beta_{mj}^{(h,s)}(v, i) - \\
& - \sum_{j=1}^{\lambda-1} D_{lj}(v) \beta_{lj}^{(l,\lambda)}(v, v) \beta_{lj}^{(h,s)}(v, i), \quad \lambda = \overline{1, h}, \quad v = \overline{1, i}.
\end{aligned}$$

Random sequence  $X_h(i)$ ,  $h = \overline{1, H}$ ,  $i = \overline{1, I}$  is represented with the help of  $H \times N$  arrays  $\{W_l^{(\lambda)}\}$ ,  $l = \overline{1, H}$ ,  $\lambda = \overline{1, N}$  of uncorrelated centered random coefficients  $W_{vl}^{(\lambda)}$ ,  $v = \overline{1, I}$ . Each of these coefficients contains information about the corresponding value  $X_l^\lambda(v)$  (crop yield figures of cereal crops, precipitation amount, intensity of the use of mineral and organic fertilizers, etc.) and coordinate functions  $\beta_{l\lambda}^{(h,s)}(v, i)$  describe probabilistic relations of  $\lambda + s$  order between components  $X_l(v)$  and  $X_h(i)$  (the impact of various factors on the crop).

Expression (1) is also true if some stochastic relations of a random sequence  $\overline{X}(i) = \{X_h(i)\}$  are absent. In this case the corresponding coordinate functions take value 0 and these relations are automatically excluded from a canonical expansion.

Vector algorithm of extrapolation for arbitrary number of components  $X_h(i)$ ,  $h = \overline{1, H}$ ;  $i = \overline{1, I}$  and  $N$  order of stochastic relations on the basis of a canonical expansion (1) is of the form [20]:

$$m_{j,h}^{(\mu,l)}(s,i) = \begin{cases} M[X(i)], & \text{if } \mu = 0, \\ m_{j,h}^{(\mu,l-1)}(s,i) + (x_j^l(\mu) - m_{j,j}^{(\mu,l-1)}(l,\mu)) \beta_{j,l}^{(h,s)}(\mu,i), \\ & \text{if } l > 1, j > 1, \\ m_{j-1,h}^{(\mu,N)}(s,i) + (x_j^1(\mu) - m_{j-1,j}^{(\mu,N)}(1,\mu)) \beta_{j-1,N}^{(h,s)}(\mu,i), \\ & \text{if } l = 1, j > 1, \\ m_{H,h}^{(\mu-1,N)}(s,i) + (x_1^1(\mu) - m_{H,1}^{(\mu-1,N)}(1,\mu)) \beta_{1,1}^{(h,s)}(\mu+1,i), \\ & \text{for } l = 1, j = 1. \end{cases} \quad (5)$$

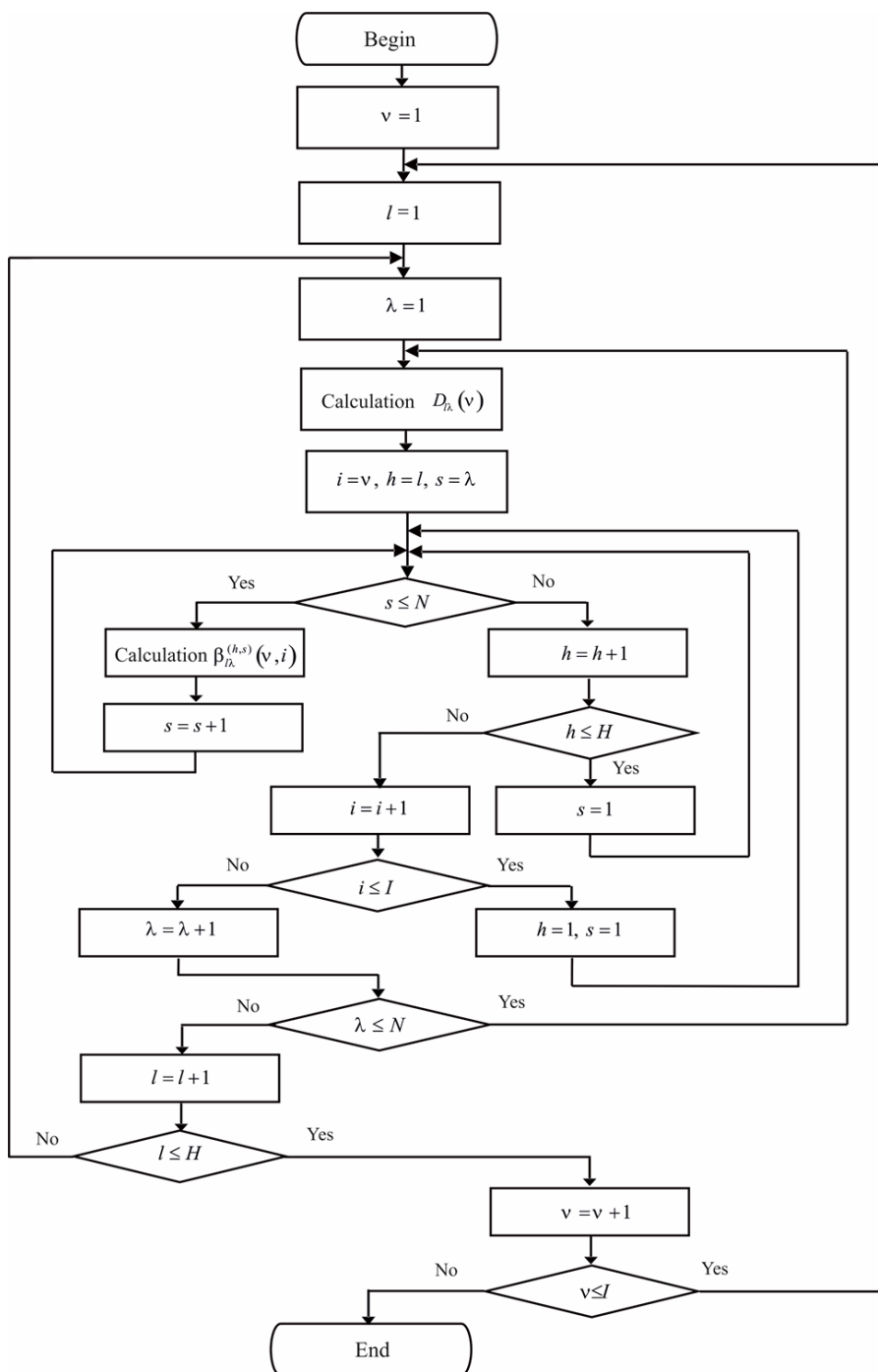


Fig. 1. Block-diagram of the algorithm for calculation of model (1) parameters



where

$$m_{x;j,h}^{(\mu,l)}(1,i) = M \left[ X_h(i) / x_\lambda^n(\nu), \lambda = \overline{1,H}, n = \overline{1,N}, \nu = \overline{1,\mu-1}; x_\lambda^n(\mu), \lambda = \overline{1,j}, n = \overline{1,l} \right]$$

- is optimal in mean-square sense estimation of future values of an investigated random sequence provided that a posteriori information  $x_\lambda^n(\nu), \lambda = \overline{1,H}, n = \overline{1,N}, \nu = \overline{1,\mu-1}; x_\lambda^n(\mu), \lambda = \overline{1,j}, n = \overline{1,l}$  is used for forecasting.

Expression for mean-square error of extrapolation with the help of algorithm (5) by known values  $x_j^n(\mu), \mu = \overline{1,k}; j = \overline{1,H}; n = \overline{1,N}$  can be written as

$$E_h^{(k,N)}(i) = M \left[ X_h^2(i) \right] - M^2 \left[ X_h(i) \right] - \sum_{\mu=1}^k \sum_{j=1}^H \sum_{n=1}^N D_{jn}(\mu) \left\{ \beta_{jn}^{(h,1)}(\mu,i) \right\}^2, \quad i = \overline{k+1,I}. \quad (6)$$

Mean-square error of extrapolation  $E_h^{(k,N)}(i)$  equals to the dispersion of a posteriori random sequence

$$X_h^{(k,N)}(i) = X \left( i / x_l^\nu(j), \nu = \overline{1,N}, j = \overline{1,k}, l = \overline{1,H} \right) = m_{H,h}^{(k,N)}(1,i) + \sum_{\nu=k+1}^{i-1} \sum_{l=1}^H \sum_{\lambda=1}^N W_{\nu l}^{(\lambda)} \beta_{l\lambda}^{(h,1)}(\nu,i) + \sum_{l=1}^{h-1} \sum_{\lambda=1}^N W_{il}^{(\lambda)} \beta_{l\lambda}^{(h,1)}(i,i) + W_{ih}^{(1)}, \quad i = \overline{k+1,I}. \quad (7)$$

Calculation method of the forecasting of future values of crop yield figures on the basis of a predictive model (5) involves the realization of the following stages:

*Stage 1.* Gathering of statistical data on the results of cereal crop harvest and production conditions;

*Stage 2.* Estimation of moment functions  $M \left[ X_l^\lambda(\nu) X_h^s(i) \right]$  on the basis of accumulated realizations of a random sequence describing the process of the change of cereal crop harvest;

*Stage 3.* Calculation of the parameters of extrapolation algorithm (5) with the help of expressions (2)-(4);

*Stage 4.* Estimation of the quality of solving of the forecasting problem for an investigated sequence using expression (6).

## 4 Discussion of the Numerical Experiment Results

Forecasting method is approbated on the basis of crop yield data [1,21] of twenty-four regions of Ukraine during the period 2007-2018 (graphs of the change of mathematical expectation and mean-square deviation are presented in Fig. 2). During the process of a numerical experiment a vector random sequence  $X_h(i), h = \overline{1,5}; i = \overline{1,12}$  ( $X_1(i), i = \overline{1,12}$  - wheat productivity, centner/ha;  $X_2(i), i = \overline{1,12}$  - barley productivity, centner/ha;  $X_3(i), i = \overline{1,12}$  - humus content, %;  $X_4(i), i = \overline{1,12}$  - amount of precipitation, mm;  $X_5(i), i = \overline{1,12}$  - use of mineral fertilizers, kg/ha) was studied.

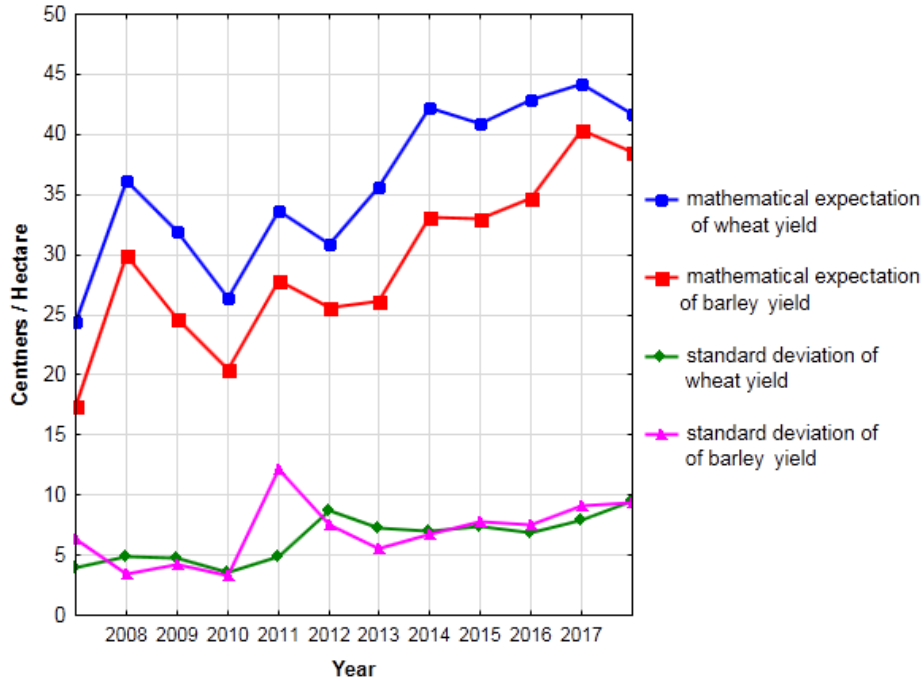


Fig. 2. Characteristics of wheat and barley productivity in Ukraine (2007-2018)

Preliminary investigations on the basis of statistic information showed that stochastic relations of  $\leq 4$  order are the most sustainable and significant. Thus, 165 values  $x_h^\lambda(i), h = \overline{1,5}, i = \overline{1,11}, \lambda = \overline{1,3}$  and 5220 not equal to zero weight coefficients  $\beta_{l\lambda}^{(h,s)}(\nu, i), \nu, i = \overline{1,12}, l, h = \overline{1,5}, \lambda, s = \overline{1,3}$  were used to forecast the crop yield figures for the last year (2018) in a forecasting algorithm (5). At the initial stage of a numerical experiment moment functions  $M[X_t^\lambda(\nu) X_h^s(i)], \nu, i = \overline{1,12}, l, h = \overline{1,5}, \lambda, s = \overline{1,3}$  were determined, and parameters  $\beta_{l\lambda}^{(h,s)}(\nu, i), \nu, i = \overline{1,12}, l, h = \overline{1,5}, \lambda, s = \overline{1,3}$  of a predictive model (5) were calculated on that base (experimental investigations were made using software product Fig. 3 that was created in Delphi programming system).

For example, values of autocorrelated functions  $M\left[\overset{\circ}{X}_h(\nu) \overset{\circ}{X}_h(i)\right], \nu = \overline{1,12}, i = \overline{1,12}, h = \overline{1,2}$  for components  $X_1(i)$  and  $X_2(i), i = \overline{1,12}$  are presented in Table 1, Table 2.

For the period 2007-2017 values of autocorrelative functions are calculated by processing of statistic data (crop yield figures in 2007-2017). For 2018 values

**Table 1.** Autocorrelative function of the component  $X_1(i)$ ,  $i = \overline{1,12}$

	2007	2008	2009	2010	2011	2012	2013	2014	2015	2016	2017	2018
2007	1,00	0,26	0,57	-0,19	0,21	0,78	0,58	0,67	0,56	0,47	0,44	0,52
2008	0,26	1,00	0,57	0,27	0,22	0,22	0,66	0,44	0,16	0,39	-0,08	0,05
2009	0,57	0,57	1,00	0,43	0,47	0,74	0,81	0,78	0,75	0,76	0,30	0,64
2010	-0,19	0,27	0,43	1,00	0,56	0,07	0,28	0,15	0,23	0,34	-0,02	0,17
2011	0,21	0,22	0,47	0,56	1,00	0,34	0,34	0,50	0,60	0,60	0,56	0,51
2012	0,78	0,22	0,74	0,07	0,34	1,00	0,66	0,86	0,83	0,82	0,60	0,85
2013	0,58	0,66	0,81	0,28	0,34	0,66	1,00	0,79	0,62	0,69	0,27	0,58
2014	0,67	0,44	0,78	0,15	0,50	0,86	0,79	1,00	0,82	0,84	0,68	0,80
2015	0,56	0,16	0,75	0,23	0,60	0,83	0,62	0,82	1,00	0,86	0,68	0,90
2016	0,47	0,39	0,76	0,34	0,60	0,82	0,69	0,84	0,86	1,00	0,61	0,86
2017	0,44	-0,08	0,30	-0,02	0,56	0,60	0,27	0,68	0,68	0,61	1,00	0,76
2018	0,52	0,05	0,64	0,17	0,51	0,85	0,58	0,80	0,90	0,86	0,76	1,00

$M \left[ \overset{\circ}{X}_h(\nu) \overset{\circ}{X}_h(12) \right]$ ,  $\nu = \overline{1,11}$ ,  $h = \overline{1,2}$  are determined on the basis of determinate models:

$$M \left[ \overset{\circ}{X}_1(\nu) \overset{\circ}{X}_1(12) \right] = 0,614M \left[ \overset{\circ}{X}_1(\nu) \overset{\circ}{X}_1(11) \right] + 0,154M \left[ \overset{\circ}{X}_1(\nu) \overset{\circ}{X}_1(10) \right] + 0,041M \left[ \overset{\circ}{X}_1(\nu) \overset{\circ}{X}_1(9) \right] - 0,282M \left[ \overset{\circ}{X}_1(\nu) \overset{\circ}{X}_1(8) \right], \nu = \overline{1,11}, \quad (8)$$

$$M \left[ \overset{\circ}{X}_2(\nu) \overset{\circ}{X}_2(12) \right] = 0,691M \left[ \overset{\circ}{X}_2(\nu) \overset{\circ}{X}_2(11) \right] + 0,088M \left[ \overset{\circ}{X}_2(\nu) \overset{\circ}{X}_2(10) \right] - 0,021M \left[ \overset{\circ}{X}_2(\nu) \overset{\circ}{X}_2(9) \right] - 0,012M \left[ \overset{\circ}{X}_2(\nu) \overset{\circ}{X}_2(8) \right], \nu = \overline{1,11}, \quad (9)$$

Parameters of equations (8)-(9) meet the minimum of the average error of forecasting (the relative error doesn't exceed 1%) of the values of correlation functions and are obtained based on the processing of data for 5 years 2009-2017 using instrument "Search for solution" of Microsoft Excel table processor.

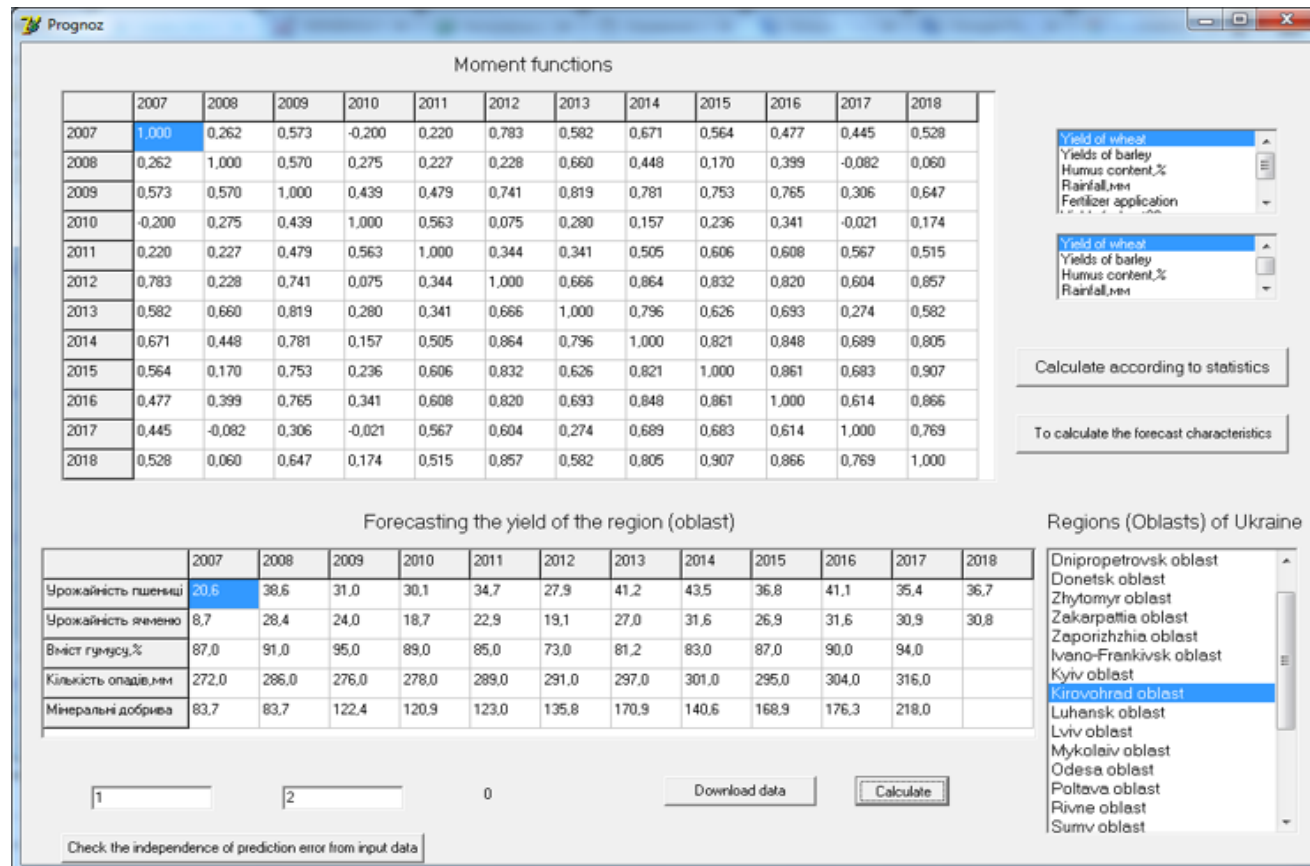


Fig. 3. Program interface for forecasting crop yield figures across regions of Ukraine

**Table 2.** Autocorrelative function of the component  $X_2(i)$ ,  $i=\overline{1,12}$

	2007	2008	2009	2010	2011	2012	2013	2014	2015	2016	2017	2018
2007	1,00	0,11	0,59	0,52	0,15	0,84	0,68	0,72	0,76	0,61	0,67	0,74
2008	0,11	1,00	0,53	0,31	0,45	0,31	0,37	0,41	0,33	0,38	-0,08	0,22
2009	0,59	0,53	1,00	0,82	0,56	0,66	0,80	0,72	0,82	0,76	0,36	0,72
2010	0,52	0,31	0,82	1,00	0,49	0,64	0,79	0,67	0,78	0,73	0,40	0,64
2011	0,15	0,45	0,56	0,49	1,00	0,40	0,52	0,35	0,44	0,42	0,22	0,36
2012	0,84	0,31	0,66	0,64	0,40	1,00	0,83	0,91	0,87	0,80	0,69	0,77
2013	0,68	0,37	0,80	0,79	0,52	0,83	1,00	0,84	0,83	0,83	0,65	0,79
2014	0,72	0,41	0,72	0,67	0,35	0,91	0,84	1,00	0,91	0,92	0,69	0,80
2015	0,76	0,33	0,82	0,78	0,44	0,87	0,83	0,91	1,00	0,93	0,73	0,92
2016	0,61	0,38	0,76	0,73	0,42	0,80	0,83	0,92	0,93	1,00	0,69	0,88
2017	0,67	-0,08	0,36	0,40	0,22	0,69	0,65	0,69	0,73	0,69	1,00	0,82
2018	0,74	0,22	0,72	0,64	0,36	0,77	0,79	0,80	0,92	0,88	0,82	1,00

In Table 3, Table 4 coordinate functions  $\beta_{hi}^{(h,1)}(\nu, i)$ ,  $\nu, i=\overline{1,12}$ ,  $h=\overline{1,2}$ , corresponding to autocorrelated functions  $M \left[ \overset{\circ}{X}_h(\nu) \overset{\circ}{X}_h(i) \right]$ ,  $i = \overline{1,12}$ ,  $h = \overline{1,2}$  and determining the degree of influence of past values of wheat and barley productivity on future values of these figures are presented.

Consolidated results of quality of solving of the forecasting problem of cereal crop harvest across all regions of Ukraine are presented in Table 5.

Thus, results of the experiment show (Table 5) that application of non-linear relations in a predictive model allows significantly increase the quality of the forecasting of cereal crop harvest. The accuracy of determination of estimations of future values of crop yield parameters is 3-5 times higher as compared with a linear model.

If necessary a predictive model used for practical purposes can be easily modified by changing the settings of a software product (Fig. 3) and entering additional statistic data into Microsoft Excel file. For example, to increase the quality of solving of a forecasting problem, number  $I$  of discretization points  $t_i$ ,  $N$  order of non-linear relations of an investigated random sequence, number  $H$  of components to take fuller account of the conditions of cereal crop production can be increased.

**Table 3.** Coordinate function  $\beta_{11}^{(1,1)}(\nu, i)$   $\nu, i = \overline{1,12}$ .

	2007	2008	2009	2010	2011	2012	2013	2014	2015	2016	2017	2018
2007	1,00	-0,26	0,43	0,35	-0,30	0,69	0,52	0,65	1,05	0,83	1,26	1,47
2008	0	1,00	0,90	0,37	0,94	-0,13	0,28	0,30	0,63	0,57	-0,89	0,67
2009	0	0	1,00	0,45	2,91	0,39	0,94	0,03	0,45	0,88	-0,02	0,80
2010	0	0	0	1,00	-1,77	0,12	0,06	0,03	-1,22	-0,71	-1,72	-3,58
2011	0	0	0	0	1,00	0,18	0,06	0,02	0,26	0,35	0,26	0,23
2012	0	0	0	0	0	1,00	0,22	0,80	1,01	0,22	4,60	2,40
2013	0	0	0	0	0	0	1,00	0,59	1,02	1,32	1,63	1,92
2014	0	0	0	0	0	0	0	1,00	2,29	0,79	3,45	3,53
2015	0	0	0	0	0	0	0	0	1,00	0,85	0,84	0,72
2016	0	0	0	0	0	0	0	0	0	1,00	0,30	0,03
2017	0	0	0	0	0	0	0	0	0	0	1,00	-1,02
2018	0	0	0	0	0	0	0	0	0	0	0	1,00

**Table 4.** Coordinate function  $\beta_{21}^{(2,1)}(\nu, i)$   $\nu, i = \overline{1,12}$ .

	2007	2008	2009	2010	2011	2012	2013	2014	2015	2016	2017	2018
2007	1,00	0,28	0,30	0,61	0,24	-0,03	-0,04	0,34	0,68	0,23	-0,11	0,10
2008	0	1,00	-0,25	-0,21	0,17	0,40	0,12	-0,85	-0,21	-0,93	-0,42	-0,63
2009	0	0	1,00	0,27	0,62	-0,21	0,63	0,62	0,49	0,69	1,17	0,28
2010	0	0	0	1,00	1,73	0,64	1,45	1,59	1,52	1,99	1,76	1,91
2011	0	0	0	0	1,00	1,82	1,02	1,12	0,21	-0,46	0,35	1,38
2012	0	0	0	0	0	1,00	1,84	1,07	-0,39	0,85	1,82	1,25
2013	0	0	0	0	0	0	1,00	-0,07	-0,38	-0,10	0,77	0,54
2014	0	0	0	0	0	0	0	1,00	0,47	0,61	0,00	0,29
2015	0	0	0	0	0	0	0	0	1,00	0,47	-0,22	0,30
2016	0	0	0	0	0	0	0	0	0	1,00	0,02	0,31
2017	0	0	0	0	0	0	0	0	0	0	1,00	-1,70
2018	0	0	0	0	0	0	0	0	0	0	0	1,00

**Table 5.** Relative errors of prognostication of cereal crop harvest.

Order of stochastic relations,	2	3	4
Relative error for wheat	6,9 %	3,2 %	1,5 %
Relative error for barley	7,1 %	3,3 %	1,6 %

## 5 Conclusion

Method of solving of an important economic problem of forecasting of cereal crop harvest is offered. A forecasting method, as well as an underlying canonical model, doesn't impose any limitations on the properties of a random sequence of change of crop yield figures (linearity, stationarity, linearity, Markov property, monotony, etc.). Taking into full account stochastic peculiarities of crop yield figures and conditions of cereal crop production allows to achieve maximum quality of solving of a forecasting problem. Results of a numerical experiment confirmed the high-accuracy characteristics of a predictive model for solving the problem of forecasting of crop yield figures for the regions of Ukraine. The model can also be used to improve the efficiency of the functioning of agricultural business enterprises. However, for microeconomic forecasting, it is necessary to modify a mathematical model taking into account the peculiarities of the economic activities of an agricultural enterprise (the composition and characteristics of the soil, weather conditions in the periods of climbing of cereals and ear crops, features of growing grain crops, taking into account the geographical location of an enterprise, etc. should be used as the parameters of a forecast model).

Application of an offered method of crop yield forecasting will allow to increase efficiency of the realization of Ukraine's Food Program and also to adjust the strategy of the use of cereal crops for production of alternative fuels [22,23]. For further studies, it is expedient to consider the possibility to use intellectual technologies [19,24] (a) for solving of the problems of crop yield forecasting and (b) for comparative analysis of the results of forecasting obtained on the basis of the approach offered in this work.

## References

1. The main site of the agricultural business. [www.latifundist.com](http://www.latifundist.com)
2. Gallego H., Kravchenko A.N., Kussul N.N., Skakun S.V., Shelestov A. Yu, Grypych Yu.V.: Efficiency Assessment of Different Approaches to Crop Classification Based on Satellite and Ground Observations. *J. Problems of control and information sciences*, №3, pp. 123-134 (2012)
3. Vijendra Kumar Boken: Forecasting Spring Wheat Yield Using Time Series Analysis. *Agronomy Journal*, Vol. 92, № 6, pp. 1047-1053 (2000)
4. Methodology of the MARS Crop Yield Forecasting System. *Eur Rep 21291 EN/1-4* (2008)
5. Savin I., Negre T. (ed.): *Agro-meteorological monitoring in Russia and Central Asian Countries*, OPOCE EUR 22210EN, Ispra (Italy), 214 p. (2006)

6. Polovyi A.M.: Modelling of hydrometeorological regime and productivity of agroecosystems. Kyiv: KNT, 342 p. (2007)
7. Kogan F., Salazar L., Roytman L.: Forecasting crop production using satellite-based vegetation health indices in Kansas, USA. *International Journal of Remote Sensing*. 33, N 9. pp. 2798–2814 (2012)
8. Kacprzyk J.: *Multistage Fuzzy Control: A Prescriptive Approach*. John Wiley & Sons, Inc., New York, NY, USA (1997)
9. Shebanin V., Atamanyuk I., Kondratenko Y., Volosyuk Y.: Application of fuzzy predicates and quantifiers by matrix presentation in informational resources modeling. *Proceedings of Conference “MEMSTECH 2016”, 22-24 April 2016, Lviv-Poljana*, pp. 146-149 (2016)
10. Tsay R.S.: *Nonlinear time series models: testing and applications*. Course in Time Series Analysis. New York: Wiley, 680 p. (2001)
11. Pugachev V.S.: *The Theory of Random Functions and its Application*. Fitmatgiz, Moscow, 720 p. (1962)
12. Box G.E.P., Jenkins G.M.: *Time-series Analysis, Forecasting and Control*. Holden-Day, San Francisco, 575 p. (1970)
13. Lozynsky O., Shcherbovskykh S.: Consideration effect of repair strategy on availability for non-redundant system using extended Markov model. *Proceeding of Conference CADSM 2011, Polyana, Svalyava, Ukraine*, pp. 2-22 (2011)
14. Wiener N.: *Extrapolation, Interpolation, and Smoothing of Stationary Time Series*. MIT Press, New-York, 163 p. (1970)
15. Kudritsky V.D.: *Filtering, Extrapolation and Recognition Realizations of Random Functions*. FADA Ltd., Kyiv, 176 p. (2001)
16. Atamanyuk I.P.: Algorithm of extrapolation of a nonlinear random process on the basis of its canonical decomposition. *J. Kibernetika i Sistemnyj Analiz*, №2, pp. 131-138 (2005)
17. Atamanyuk I.P.: Optimal Polynomial Extrapolation of Realization of a Random Process with a Filtration of Measurement Errors. *Journal of Automation and Information Sciences*. Volume 41, Issue 8, Begell House, USA, pp. 38-48 (2009)
18. Atamanyuk I.P., Kondratenko Y.P., Sirenko N.N.: Forecasting Economic Indices of Agricultural Enterprises Based on Vector Polynomial Canonical Expansion of Random Sequences. *Proceedings of the 12th International Conference ICTERI'2016, CEUR-WS, Vol-1614*, pp. 458-468 (2016)
19. Atamanyuk I., Kondratenko Y.: Calculation Method for a Computer's Diagnostics of Cardiovascular Diseases Based on Canonical Decompositions of Random Sequences. *Proceedings of the 11th International Conference ICTERI-2015, Batsakis, S., et al. (Eds), CEUR-WS, Vol. 1356, Lviv, Ukraine, May 14-16, pp.108-120* (2015)
20. Atamanyuk I.P.: Polynomial algorithm of optimal extrapolation of stochastic system parameters. *J. Upravlyayushchie Sistemy i Mashiny*, №1, pp. 16-19 (2002)
21. State Statistics Service of Ukraine. [www.ukrstat.gov.ua](http://www.ukrstat.gov.ua)
22. Goncharuk A.G., Havrysh V.I., Nitsenko V.S.: National features for alternative motor fuels market. *Int. J. of Energy Technology and Policy*, Vol.14, No.2/3, pp. 226-249 (2018)
23. Kondratenko Y.P., Kozlov O.V., Kondratenko, G.V., Atamanyuk, I.P.: Mathematical Model and Parametrical Identification of Ecoprogenesis Plant Based on Soft Computing Techniques, *Complex Systems: Solutions and Challenges in Economics, Management and Engineering*, Book Series: Studies in Systems, Decision and Control, Vol. 125, Berlin, pp. 201-233 (2018) DOI: [https://doi.org/10.1007/978-3-319-69989-9\\_13](https://doi.org/10.1007/978-3-319-69989-9_13)
24. Trunov A.N.: An Adequacy Criterion in Evaluating the Effectiveness of a Model Design Process. *Eastern-European Journal of Enterprise Technologies* 1(4(73)), 36-41 (2015)



# Cloud Based Architecture of the Core Banking System

Andrii Roskladka<sup>1</sup>[0000-0002-1297-377X], Nataliia Roskladka<sup>1</sup>[0000-0001-7333-4050],  
Ganna Kharlamova<sup>2</sup>[0000-0003-3614-712X] and Roman Baglai<sup>1</sup>[0000-0002-4067-4929]

<sup>1</sup> Kyiv National University of Trade and Economics,  
Kyoto st. 19, 02156, Kyiv, Ukraine

a.roskladka@knuce.edu.ua, n.roskladka@knuce.edu.ua,  
romanbaglai@gmail.com

<sup>2</sup> Taras Shevchenko National University of Kyiv,  
Vasylkivska st. 90, 03022, Kyiv, Ukraine

akharlamova@ukr.net

**Abstract.** The article contains a study of cloud technology and standards applicable to Core Banking System (CBS). National regulators often require storage of the data on physical servers of the country where the bank is registered. This is probably due to the lack of awareness of cloud technology data protection capabilities on the regulator side. Although main cloud service providers comply with international security standards, such as Payment Card Industry Data Security Standard (PCI DSS), International Organization for Standardization (ISO 9001:2015, ISO/IEC 27001:2013, ISO/IEC 27017:2015) and many other national security standards [3]. This means they offer much higher degree of information security that the bank can afford within own infrastructure. Modern mathematical systems and methods have been used to define an optimal configuration of cloud based platform for CBS. An analytical model was built based on the EC2 memory optimized class instances configuration.

**Keywords:** core banking system, OLTP, OLAP, Postgresql, Amazon elastic cloud compute

## 1 Introduction

Cloud technology today is enabling innovation and digital transformation of banking industry. Lagging behind FinTech startups large system banks start to apply cloud computing in various spheres of their activity.

Digital public channels for customers like Android and IOs applications, corporate web site etc. is usually the first step in this direction. Second step in migrating to the cloud is high performance computing for public data analytics as for instance risk scoring models. Third step is typically IaaS solutions to ensure business continuity and moving the secondary data center to the cloud.

CBS is usually one of the last steps in cloud migration as it is heavier than two steps mentioned earlier and involves risk related to customer data confidentiality,

integrity and availability. Main risks attached are related to moving customer data to the cloud.

European General Data Protection Regulation (GDPR) requirements specify that customer data should not be stored permanently without legitimate reason of its processing, storing customer data in the cloud require either customer consent or anonymization. Banks are sitting on Big Data scale infrastructure which has a tendency to grow exponentially. Those volumes demand ever increasing computing capacity for processing.

Migration of CBS to the cloud is the subject of this research. The aim of the article is to research the architecture and configuration of services to enable the cloud deployment of CBS. The research is based on the data protection requirements mentioned above including architecture schemes, data flow UML diagrams and mathematical modeling.

## **2 Research methodology**

The theoretical and methodological background is the fundamental principles of the systematic approach, the methods of scientific abstraction, analysis and synthesis, induction and deduction, the dialectical method of knowledge of information technology.

In particular the following scientific methods are used in research:

- graphical method – Unified Modeling Language (UML) and the Open Group Architecture Framework (TOGAF) were used by the authors to visualize the design of the system;
- classification method – Common Attack Pattern Enumeration and Classification (CAPEC), Open Web Application Security Project (OWASP) when determining the priority directions of application of different IT security mechanisms for specific models of cloud technologies deployment;
- quantitative analysis method – multicriteria optimization in Mathcad to minimize the time and cost of using the cloud service.

The information basis for the study is data of Amazon web services, Microsoft, Temenos and other technical documentation available publicly.

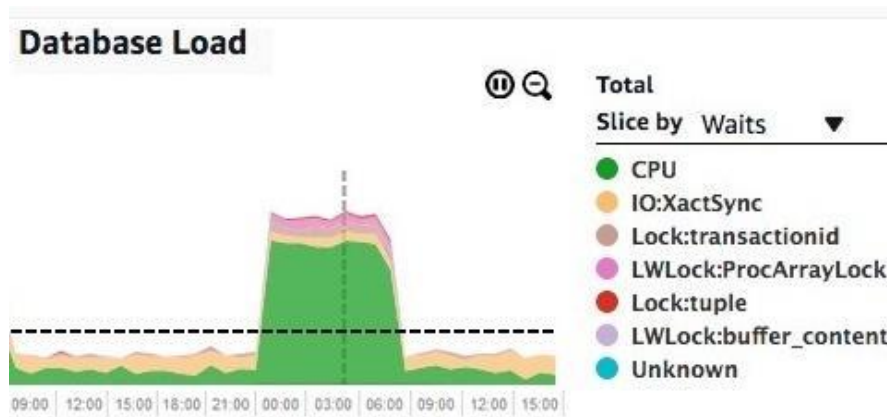
## **3 Literature and hypothesis development**

The problems of using cloud technologies in various socio-economic spheres are studied in [12]. Among the main directions of solving the problem of application of the Public Cloud and Hybrid Cloud deployment models, identified in the resources of the world scientific periodical, publications [15, 16, 17] can be singled out. These publications take into account the specifics of securing information that constitutes banking secrecy, but there are no proposals for data depersonalization. In particular, work [20] is devoted to solving the problem of confidentiality of data by encryption, but this imposes significant restrictions on data processing.

The work of other scientists [12] does not fully take into account the specifics of IT security provision for banking institutions. Works [17, 12] contain proposals on the use of cloud technologies, but do not contain a comprehensive analysis of the architecture of banking information systems based on cloud technologies, taking into account regulatory constraints.

As mentioned earlier Core Banking System is usually not the first choice for cloud migration. Even if migration offers great cost saving potential banks don't have enough risk appetite to go for it. Maintaining such a status quo requires keeping a lot of hardware capacity On-Premise to deal with CBS workloads.

Most of this capacity is utilized during end of day procedures when the system is not available for users as resources are completely engaged for on-line analytical processing (hereinafter OLAP) tasks (see Fig.1.). The rest of the day the load on the system is rather low, which means that resources are underutilized and used completely inefficient. In such situation huge capital investments should be made for procurement and operative expenditures for further maintenance of such hardware.



**Fig.1.** CBS Data Base server resources work load report (Source: [10]).

Moving the OLAP processing work load to the cloud provides possibility to achieve major cost saving and potentially make CBS system available 24/7. As OLAP tasks will be carried out in the cloud on-premise replica will be available for user transactions workload.

Cloud technology offers great efficiency of hardware utilization due to scalability and flexibility, which leads to major cost saving and improved time to market, as underlying infrastructure administration tasks are handled by cloud service provider. To uncover this potential it is necessary to manage the risks attached.

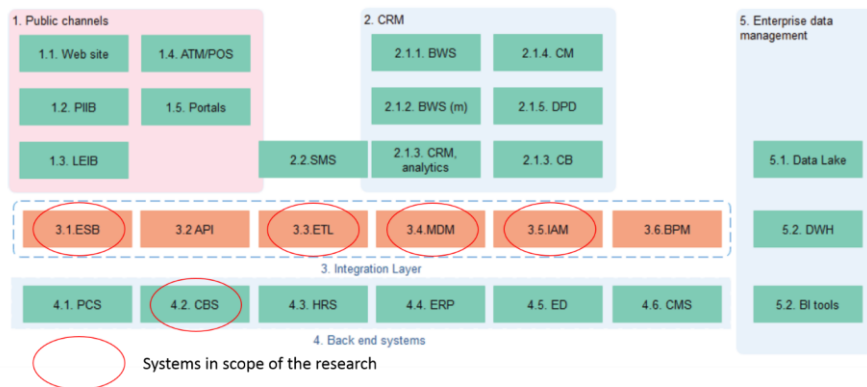
Major risks are GDPR requirements (Banks must act as GDPR agents and to be in control of customer data all the time) and local regulators requirements to store the data within borders of the home country. Unanimisation of the data allows to avoid both risks.

## 4 Objective and Context of Research

The objective of the research is to:

- to develop the concept on how to migrate huge computing workloads to the cloud, still being compliant with GDPR and national regulator requirements. Unanimisation of the customer data is described as a solution;
- to choose the cloud service provider based on TCO;
- to prepare the IT solution architecture which combines both real time and batch data processing. Unlike traditional use case the data should not only be migrated to the cloud database but also replicated back on premise. Security requirements for data confidentiality integrity and availability must be met;
- to find mathematical solution for the problem of selection of optimal configuration for the cloud computing instance.

The Bank enterprise high-level architecture scheme (see Fig. 2) can be logically separated into 5 blocks.



**Fig.2.** High level architecture scheme of bank's IT landscape (Source: [10])

Those include Public Channels, Customer Relationship Management, Integration Layer, Back-end Systems and Enterprise Data Management. In scope of this research following systems of IT landscape will be considered:

Integration layer - Enterprise Service Bus, Extract Transform Load jobs, Master Data Management, Identity Access Management

Back end systems - Core Banking System.

Unanimisation of customer data is supplementary measure to ensure confidentiality pursuant to requirements of GDPR, PCI DSS and other similar standards. To de-personalize the customer data replacing it with secret ID in all CBS Data Base (hereinafter DB) schema tables where it resides.

Secret ID formed from unique customer ID applying specified algorithm in Table 1. The data access to be restricted to DB administrators only.

**Table 1.** Simplified structure of Master Data Management system Dictionary

Unique customer ID	Secret customer ID	Customer ID in system X,Y,Z
--------------------	--------------------	-----------------------------

MDM system should act as a source and universal point of truth about customer data for all other systems of Bank`s IT landscape. Pre-requisite for MDM is a single front end to enter the customer data and real time distribution to consuming systems including CBS. MDM is a source of Unique and secret customer IDs for CBS and handles customer deduplication process. As this is fully on-premise procedures integration will not be further subject in the research.

## 5 Results

### 5.1 Choosing the Cloud Service Provider Based on TCO

Relational DB platform as a service (PaaS) providers which were named leaders by Gartner considered for Total cost of ownership comparison. TCO (Table 2) was calculated with the help of TCO calculators available on official company web sites.

**Table 2:** Amazon vs Microsoft TCO comparison

Parameters	Amazon RDS	Azure sql
Region	EU Frankfurt	West Europe
Environment	On premise	On premise
Servers type	Virtual Machines	Virtual Machines
Number of virtual machines	2	4
Number of cores	64	64
RAM GB	256	256
DB type	My sql	My sql
Storage type	NAS	NAS
Storage capacity GB	3000	3000
Max concurrent users	NA	1000
Bandwidth GB	3752	2000
Cost per Kw USD	0,36	0,36
on-premise cost USD	370,401	327,228
AWS USD	120,676	208,201
Saving absolute amount USD	249,725	119,027
Saving relative amount	67%	36%

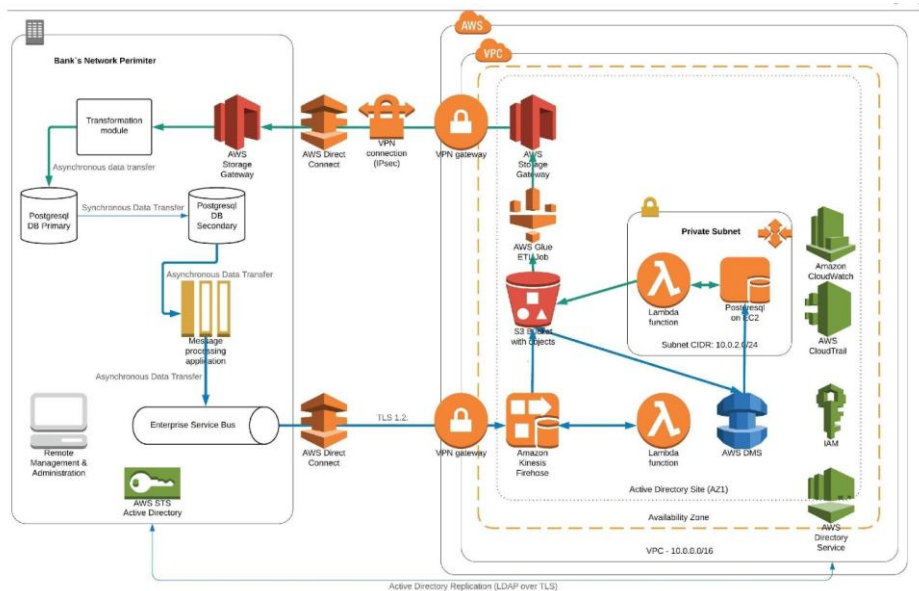
Source: [4, 7, 22, 23]

TCO calculator comparing on-premise and cloud costs with parameterization functionality was not found on Google web site. Amazon and Microsoft TCO were compared.

My SQL Relational database service (hereinafter RDS) was chosen as a base on-premise vs Cloud for TCO comparison. All the parameters were made as similar as possible to get the relevant result. Based on the results of TCO comparison Amazon web services (hereinafter AWS) solution was selected (almost twice more efficient).

## 5.2 AWS Solution Architecture Overview

The following diagram shows the solution architecture (Fig. 3).



**Fig.3.** IT solution architecture based on AWS

The principles behind this architecture are the following:

1. Compliance with Service oriented architecture principles.
2. Server less hybrid cloud – heavy workloads uploaded to the cloud to optimize cost, on-premise infrastructure is used for customer data processing.
3. Scalability and maximum efficiency of computing utilization with AWS "pay as you go" auto scaling model.
4. Enhanced security. Integrity, confidentiality and availability is ensured by the following stack of technology - TLS 1.2, Virtual Private Cloud, Encryption, IPsec VPN connection, LDAP over TLS, SAML and IAM roles for each and every Application Programming Interface (hereinafter API) function, audit of every API call.
5. Separation of on-line transaction, analytical processing and batch loads using AWS Lambda on each step of data replication process.
6. Two dataflows:

- outgoing (blue line Fig. 3) from on-premise to the cloud.
  - incoming (green line Fig. 3) from Cloud to on-premise.
7. Enhanced reconciliation – replication of all changes in data base real time and validation in Transformation Module after bulk ETL load on-premise.
  8. Efficiency – two similar schemas on-premise (customer data included) and Virtual Private Cloud (Unonimoused data) allow to replace INSERT and UPDATE SQL statements with INNER JOIN which is much more efficient in terms of DB server resources consumption.
  9. Optimization of concurrent database connections – By buffering records to Simple Storage Service (hereinafter S3) and using Lamda functions as elastic scheduler it is possible to limit the Postgres DB uptime only to actual end of day procedures duration after logical midnight to 3 am, thus optimizing the cost.

The on-premise infrastructure consists of Postgresql DB, Message processing application, ESB, Trasformation module, AWS Storage Gateway, Remote management and administration.

The Postgresql DB – Open source database management systems which offers enterprise scale reliable solution at no licensing cost. Primary and Stand-by databases with synchronous data transfer to ensure failover disaster recovery with minimum downtime.

The Message procession application – Java based application connected with Postgresql DB Stand-by replica with Java DataBase Connectivity (hereinafter JDBC) read only interface. Such approach ensures that there is no negative impact on Primary DB performance due to additional read requests on big number of tables.

The Enterprise service bus – middle ware which uses Message Queue (hereinafter MQ) protocol to route message processing application JavaScript Object Notation (hereinafter JSON) messages to AWS Kinesis Firehose.

The Transformation module—a staging area, which acts as intermediate storage area used for data processing ETL process to replicate data from the AWS cloud to on-premise.

In relational DB with Atomicity, Consistency, Isolation, Durability (ACID) requirements the SQL statements take less server computing resources when the data is stored closer i.e. ideally in one table. The greater the number of table and relations the bigger amount of computing resources is consumed.

Under such circumstances INSERT and UPDATE statements on every row of each table consume a lot of DB server resources. Therefore cost saving effect of migrating workload to the cloud could be totally diminished.

To avoid such effect:

- a) Schemas of on-premise and Cloud Postgresql DB replica contain the same columns except those containing customer data. Those columns are cropped and replaced with Secret customer ID during migration to the cloud using AWS Database Migration Service (initial load).
- b) INSERT and UPDATE SQL statements are not used by ETL process in Transformation module for daily replication of the calculation results from the Cloud Postgresql DB to on-premise replica.

c) For daily replication of calculation results from the Cloud Postgresql DB to on-premise and adding columns containing customer data the INNER JOIN SQL expression is used. INNER JOIN is much more efficient and does not require such computing power.

The AWS offers enhanced IT Security capabilities for all critical attributes of data security (Integrity, Confidentiality, Availability).

The Virtual Private Cloud is a Virtual perimeter securing systems data, interfaces and endpoints from unauthorized access and modification.

Security events Monitoring is provided by Amazon CloudWatch (CloudWatch) with triggers for suspicious activity and security alerts configurable policies.

Using AWS CloudTrail (CloudTrail) it is possible to audit every API call and store this data historically with visualization in the form of reports and dashboards.

Integrity of inter system data transfer is ensured by Transport layer security protocol version 1.2 (TLS 1.2.)

The AWS Kinesis Firehose is a streaming data processor which transmits the event data from on-premise infrastructure for further processing in the cloud in the form of JSON files [1].

The AWS Lambda is automated scheduler which runs AWS services code via API according to the per-defined schedule or when specific event triggers the Lambda function. In proposed IT solution Lambda function also transforms JSON files into comma-separated value (hereinafter CSV) for further processing by Database migration service (hereinafter DMS).

The AWS S3 buckets are used to store the data on all sequence of ETL processes.

The AWS DMS in most frequent use cases is used to perform bulk data upload (Initial load) from on-premise DB replica to cloud DB replica to perform further switch off of on-premise replica. DMS service also supports continuous replication to achieve the same data state/synchronize both on-premise and cloud DB replicas. In proposed solution the on-premise Replica is not switched off therefore after initial load synchronization capabilities of DMS is used perpetually. To optimize costs DMS and Postgresql DB instances uptime is regulated by scheduled lambda function.

The AWS Aurora Postgresql compatible DB – AWS Database system management service for deployment of relational open source DB Postgresql in the AWS cloud. According to Amazon Aurora DB also offers up to three times better performance in AWS cloud than original Postgresql.

The AWS Glue ETL is Extract Transform Load engine which can use triggers to initiate jobs either on a schedule or as a result of a specified event and determines where target data resides and which source data populates the target. In proposed IT Solution AWS Glue is used in conjunction with AWS Lambda functions. The AWS Glue Data Catalog contains references to data that is used as sources and targets of ETL jobs in AWS Glue. The AWS Glue Data Catalog is an index to the location, schema, and runtime metrics of the data. It is possible to run a crawler to take inventory of the data in the data stores and add metadata tables into the Data Catalog. In proposed IT solution AWS glue write a Python ETL script that uses the metadata in the Data Catalog to do the following:

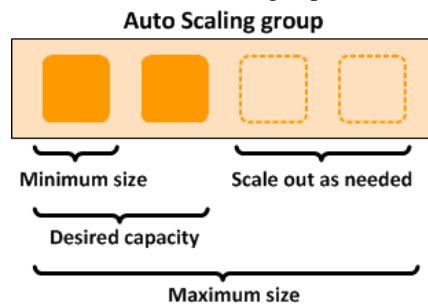


- Join the data in the different source files together into a single data table (that is, denormalize the data).
- Filter the joined table into separate tables by type of legislator.
- Write out the resulting data to separate schema in the Transformation module for further matching with personalized customer data on-premise using INNER JOIN SQL expression.

RDS currently does not offer such a scalability options and memory optimized instances classes as EC2. As specified by CBS performance testing results [11] for relational database input/output operations per second for storage and RAM plays even bigger role than vCPU computing power and number. Therefore memory optimized instance classes were selected for the proposed IT solution. RDS currently does not provide such instance class options [5].

### 5.3 AWS Auto Scaling Capabilities

The following diagram shows the solution scaling capabilities (Fig. 4).



**Fig. 4.** EC2 horizontal auto scaling (Source: [5])

Horizontal scaling means that EC2 instances can be added automatically when demand for cloud computing resources is increasing.

Auto Scaling creates and manages the CloudWatch alarms that trigger the scaling policy and calculates the scaling adjustment based on the metric and the target value.

A target tracking scaling policy assumes that it should perform scale out when the specified metric is above the target value for instance the target value could be 80% of CPU utilization. The AWS EC2 can either launch instances (scale out) or terminate instances (scale in), within the range that the user choose, in response to one or more scaling policies.

Vertical scaling. AWS EC2 allows to customize the number of CPU per instance which is configured manually before instance is launched, changing the configuration requires restart. CPU number settings persist when instances are added automatically (horizontal scaling). Decreasing number of CPUs allow to optimize the licensing costs of software with an instance that has sufficient amounts of RAM for memory-intensive workloads but fewer CPU cores.

#### 5.4 The Mathematical Model for Choosing the Optimal Configuration for a Cloud Server

Consider setting the task of choosing the optimal IT PaaS solution (Postgresql on the EC2 module) for CBS, including type and configuration.

It is necessary to evaluate the workload of the cloud replica of the Postgresql database when executing end of day procedures for closing the Bank's operational day in order to minimize the time and cost of using the cloud service. Empirical observations made it possible to determine the basic requirements for scalability and configuration:

- the size of the database is about three terabytes;
- the client base has up to 15 million clients;
- the number of transactions is 50 million per day;
- the number of customer accounts is 25 million.

Given these parameters and the specifics of ACID requirements for a relational database, OLAP workloads require high computing power that can meet the following minimum server configuration requirements:

- the size of RAM - not less than 256 GB;
- the size of permanent memory is not less than 3 TB.

A typical operating day closing rule usually includes 4 OLAP tasks (indicative list, depending on system architecture, supplier, and implementation).

Task 1. Aggregation of billing and payments according to client's agreements.

Task 2. Commissions for cash services, accrual of interest on current accounts, overdraft, loans and deposits.

Task 3. Aggregation of data on overdue loans, and the beginning of the reference days of overdue debt. Calculation of effective interest rate on loans and deposits. Re-valuation of currency position. Calculation of provisions for impairment losses.

Task 4. Formation of the daily balance file (aggregate assets and liabilities). Formation of statistical reporting files.

To solve each task, the minimum required number of processor cores in the server configuration is determined.

Let us introduce the symbols.

$k$  – quantity of tasks of end of day procedure for closing the operational day of the bank;

$n$  – quantity of the module's types (instance);

$CPU_j$  – maximum quantity of cores (CPU) in module of type  $j$ ;

$f_i(CPU_j)$  – function of dependency of processing time for the task number  $i$

from the maximum quantity of CPU in module of type  $j$ ;

$p_i$  – minimum required quantity CPU to solve the task number  $i$ ;

$RAM_j$  – size of RAM in module of type  $j$ ;

$Storage_j$  – size of storage in module of type  $j$ ;

$R_i$  – minimum required size of RAM to solve the task number  $i$ ;

$S_i$  – minimum required size of storage to solve the task number  $i$ ;

$c_j$  – the cost of using a module of type  $j$  per hour;

$t_{ij}$  – time of using a module of type  $j$  to solve the task number  $i$ .

$x_{ij}$  – quantity of modules of type  $j$ , which used to solve the task number  $i$ .

The mathematical model of the problem has the form:

$$F_1 = \sum_{i=1}^k \sum_{j=1}^n t_{ij} = \sum_{i=1}^k \sum_{j=1}^n x_{ij} \cdot f_i(CPU_j) \rightarrow \min \quad (1)$$

$$F_2 = \sum_{i=1}^k \sum_{j=1}^n c_j \cdot t_{ij} = \sum_{i=1}^k \sum_{j=1}^n c_j \cdot x_{ij} \cdot f_i(CPU_j) \rightarrow \min \quad (2)$$

$$\begin{cases} \sum_{j=1}^n CPU_j \cdot x_{ij} \geq p_i, \\ \sum_{j=1}^n x_{ij} \cdot RAM_j \geq R_i, \\ \sum_{j=1}^n x_{ij} \cdot Storage_j \geq S_i, \\ i = 1, \dots, k \end{cases} \quad (3)$$

$$x_{ij} \geq 0, \quad x_{ij} - \text{whole.}$$

The problem (1) - (3) relates to the class of tasks of multicriteria optimization. The target function (1) is the condition of minimizing the time of using the cloud service and the target function (2) minimize the cost of its use.

Solving problems with several functions is a rather difficult problem, even for two functions [19]. With the practical use of the model, we can apply a method of priorities, that consists in the fact that at the first stage we will solve a one-problem problem with a smaller target priority (for example, the problem (1), (3)), and in the second stage, the problem (2), (3) with the include to the system of restrictions (3) an inequality, which does not allow to deteriorate the optimal value of the objective function (1) obtained in solving the optimization problem (1), (3) in the first stage.

Consider a numerical example of using the model. In [14] shows the options for possible configurations of cloud servers. Consider setting the task of choosing the optimal IT PaaS solution (Postgresql on the EC2 module) for CBS, including type and configuration.

### 5.5 Program realization of the mathematical model

To solve the problem (1) - (3) the system MathCAD 15.0 was used. In Fig. 6 shows the initialization process of the model's initial data.

When constructing a matrix M, the dependence of the time of the task on the quantity of server cores was used to empirical investigations of the authors of the article, which was conducted using a 32-core processor. The time for each of the four closure tasks is presented in Table 3.

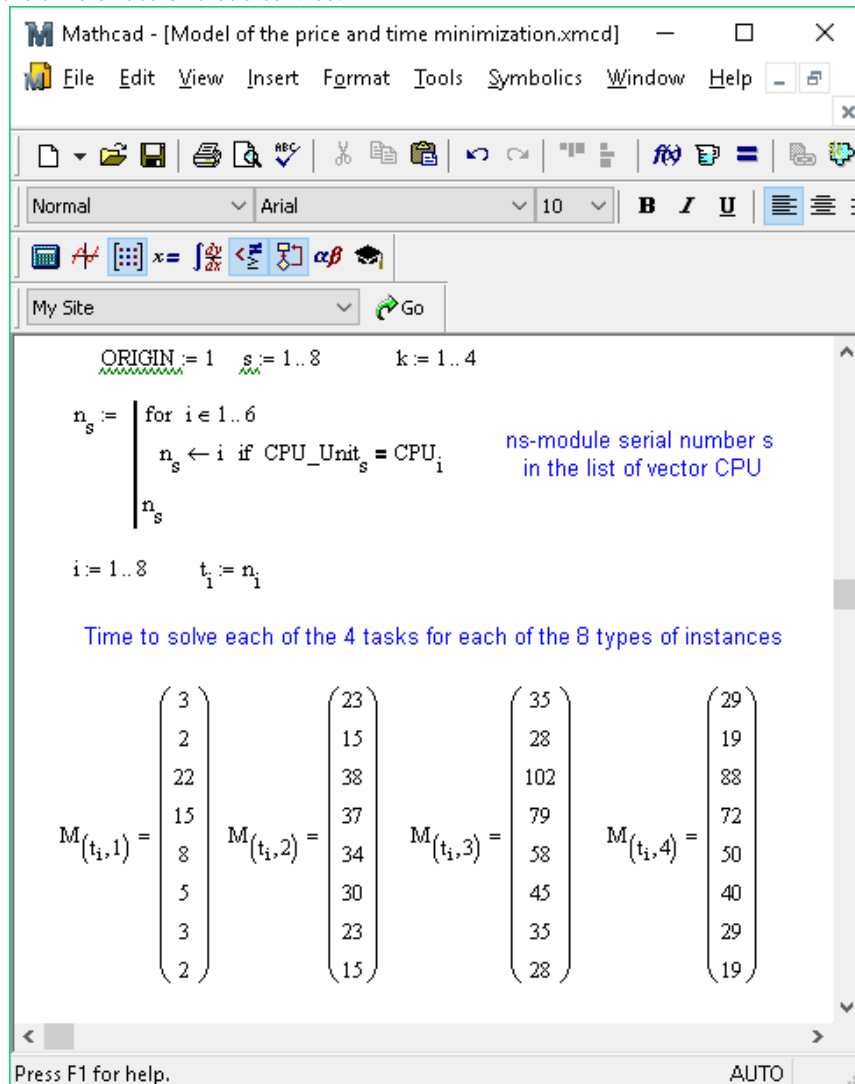
**Table 3:** Time to solve the task by 32-core processor

Task number	1	2	3	4
Time to solve the task	5	30	40	45

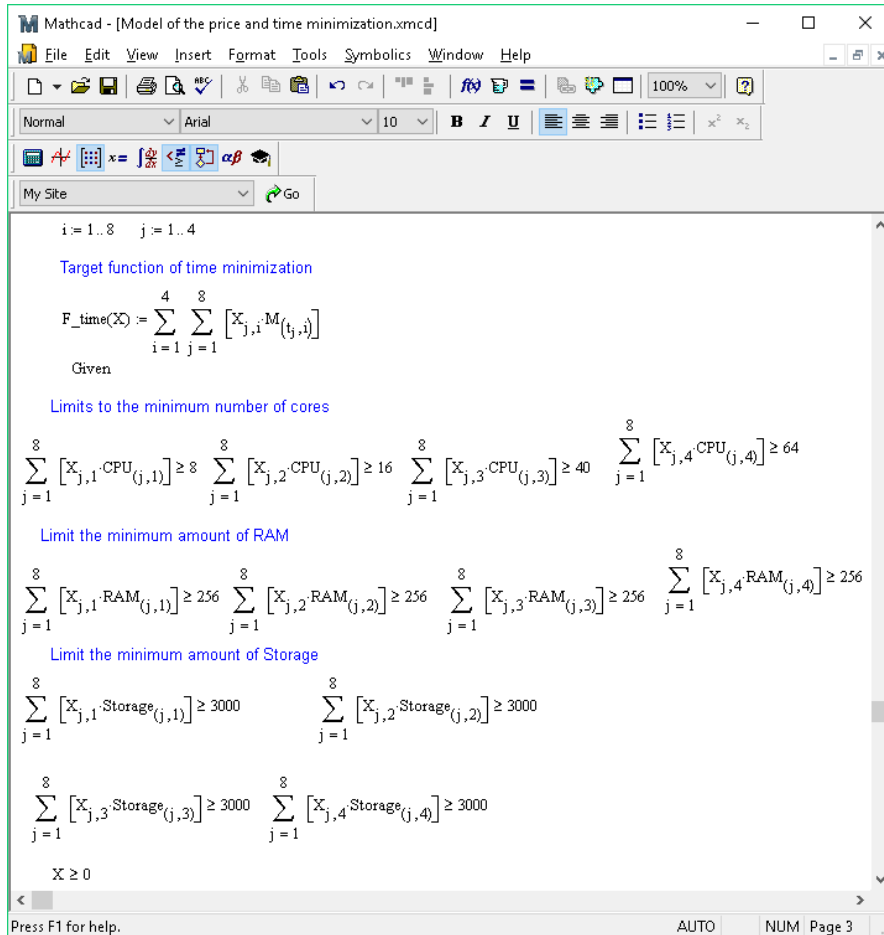
Source: Creation of authors

The values of the elements of the matrix M is offset by extrapolating empirical data to another number of processor cores.

In Fig. 5-6 depicts a phased process of forming a mathematical model for optimizing the time of use of cloud service.



**Fig. 5.** Find the time to solve the task depending on the type of instance (Source: Creation of authors)



**Fig. 6.** Formation of a mathematical model for minimizing the use of cloud service time (Source: Creation of authors)

When constructing a matrix  $M$ , the dependence of the time of the task on the quantity of server cores was used to empirical investigations of the authors of the article, which was conducted using a 32-core processor. The time for each of the four closure tasks is presented in Table 3.

When constructing a matrix  $M$ , the dependence of the time of the task on the quantity of server cores was used to empirical investigations of the authors of the article, which was conducted using a 32-core processor. The time for each of the four closure tasks is presented in Table 3.

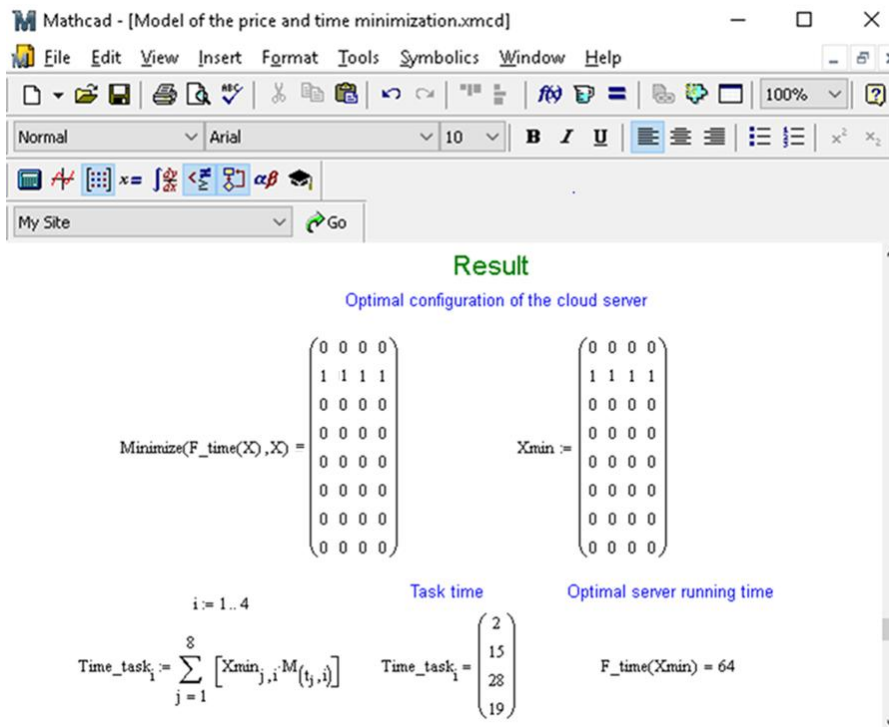
In fig. 6 shows the result of time optimization of the cloud service. To get the result, use the Minimize function of the MathCAD system. According to the obtained

solution, the configuration is optimal, shown in the table 4. The minimum server time for such a hardware configuration is 64 minutes.

**Table 4:** The optimal configuration of a set of servers

Task number	1	2	3	4
Name of server type	X1 Extra High-Memory 32xlarge	X1 Extra High-Memory 32xlarge	X1 Extra High-Memory 32xlarge	X1 Extra High-Memory 32xlarge
Task time, min	2	15	28	19

Source: Creation of authors



**Fig. 7.** The optimal configuration of a set of servers (Source: Creation of authors)

Solving the multicriteria problem (1) - (3) with the main target function of minimizing the cost of using cloud service is by connecting to the system (3) the restriction

$$\sum_{i=1}^k x_{ij} \cdot CPU_j \cdot f_i(CPU_j) \leq 64$$

In this case, the minimum value of the cost of using the cloud service is

$$F_{2\min} = 15.15145\$$$

## 6 Conclusion

IT solution of cloud based banking system designed in scope of the research allows to migrate huge computing workloads to the cloud, still being compliant with GDPR and national regulator requirements. Unanimousness of the customer data is described as a solution for mitigation of risks related to customer data confidentiality and necessity for customer consent to place the data to the cloud.

Based on the results of TCO comparison AWS solution was selected. AWS solutions are also beneficial in terms of Vendor dependency risks minimization. As AWS offers platforms compatible with most of the commercial and open source software and it is possible to migrate the data from cloud back to on-premise if necessary. In the solution described by the author this data migration functionality is used for daily replication of the data from the cloud to on-premise.

IT solution architecture designed by the Author combines both real time and batch data processing. Unlike traditional use case the data is not only be migrated to the cloud database but also replicated back on-premise. Security requirements regulated by the standards for data confidentiality integrity and availability are fully met with respective cloud based technology.

Mathematical solution for the problem of selection of optimal configuration for the the cloud computing EC2 instance was found. Following the model objectives of target function of minimum cost and maximization of computing capacity EC2 memory optimized instance class type X1 Extra High-Memory 32xlarge was found as optimal. In the multi criteria options for decision and constrains defined the calculation result showed that this is the most cost efficient instance which is also the most powerful instance offered by AWS. Single instance capacity is enough horizontal scaling is not necessary. The CBS end of day procedures workload is defined to large extent by the number of customers and customer transactions per day. As customer base and average number of transactions are relatively stable numbers fluctuation does not show huge peaks and falls.

Vertical scalability (decreasing number of CPUs) was not considered as Postgersql DB is open-source SW and does not require license procurement. According to Amazon pricing model decreasing number of EC2 instance CPUs does not effect cost. In case of commercial DB management system it might make sense to decrease the number of CPUs as license pricing is usually linked to the number of CPUs.

## References

1. Amazon Kinesis cloud service. Cloud guru web site 2019, <https://read.acloud.guru/deep-dive-into-aws-kinesis-at-scale-2e131ffcfa08>, last accessed 2019/05/11
2. Amazon S3 web service SLA. Amazon web services official web site 2019, <https://aws.amazon.com/ru/s3/sla/>, last accessed 2019/05/11
3. Amazon web services standards compliance. Amazon web services official web site 2019, <https://aws.amazon.com/ru/compliance/programs/>, last accessed 2019/05/11
4. Amazon web services TCO calculator. Amazon web services official web site 2019, <https://aws.amazon.com/ru/tco-calculator/>, last accessed 2019/05/11
5. Amazon web services technical documentation. Amazon web services official web site 2019, <https://docs.aws.amazon.com/index.html>, last accessed 2019/05/11
6. Antonopoulos, N., & Gillam, L. (2010). *Cloud computing*. London: Springer, 382.
7. AWS vs Azure vs Google cloud comparison. Red pixie web site 2019, <https://www.redpixie.com/blog/aws-vs-azure-vs-google-cloud>, last accessed 2019/05/11
8. Baglai, R.: Cloud identity access management for banks. *Scientific Letters of Academic Society of Michal Baludansky*, no. 2A, 16-25 (2018).
9. Baglai, R.: Cloud technology security threats for banks. *Information processing systems*, 1 (152), 127-135 (2018).
10. Baglai, R.: Research of deployment models of cloud technologies for banking information systems. *Technology audit and production reserves*, 3/4(41), 47-52 (2018).
11. Benchmark Results for Temenos T24 (2010). Intel official web site, <https://www.intel.com.br/content/dam/doc/report/performance-xeon-7500-temenos-t24-with-sql-server-2008-r2-on-intel-based-nec-servers-report.pdf>, last accessed 2019/05/11
12. Carlin, S., Curran, K.: Cloud computing technologies. *International Journal of Cloud Computing and Services Science*, 1(2), 59 (2012).
13. de Meijer, C., Brown, A.: Transaction banking in the cloud: Towards a new business model. *Journal of Payments Strategy & Systems*, 8(2), 206-223 (2014).
14. EC2 instances configuration database. Ec2instances info website 2019, <https://www.ec2instances.info/>
15. Ekanayake, J., Fox, G.: High performance parallel computing with clouds and cloud technologies. In *International Conference on Cloud Computing*, Springer, Berlin, Heidelberg, 20-38 (2009).
16. Fenu, G., Surcis, S.: A cloud computing based real time financial system. In *2009 Eighth International Conference on Networks*, 374-379 (2009).
17. Ganon, Z., Zilbershtein, I. E.: Cloud-based performance testing of network management systems. In *Computer Aided Modeling and Design of Communication Links and Networks, 2009. CAMAD'09. IEEE 14th International Workshop on*, 1-6 (2009).
18. Microsoft Azure TCO calculator. Microsoft official web site 2019, <https://azure.microsoft.com/en-gb/pricing/>, last accessed 2019/05/11
19. Yemets, O. A., Roskladka, A. A.: Algorithmic solution of two parametric optimization problems on a set of complete combinations. *Cybernetics and Systems Analysis*, Volume 35, Issue 6, 981-986 (1999).
20. Sharma, R., Trivedi, R. K.: Literature review: cloud computing-security issues, solution and technologies. *International Journal of Engineering Research*, 3(4), 221-225 (2014).
21. Google TCO calculator. Google official web site 2019, <https://cloud.google.com/pricing/>
22. Microsoft Azure TCO calculator. Microsoft official web site 2019, <https://azure.microsoft.com/en-gb/pricing/>, last accessed 2019/05/11



# Forecasting Prices on the Stock Exchange Using a Trading System

Liubov Pankratova<sup>1</sup>[0000-0002-1403-9454], Tetiana Paientko<sup>2</sup>[0000-0002-2962-308X], and Yaroslav Lysenko<sup>3</sup>

<sup>1</sup> National University of Life and Environmental Science, 27 Heroiv Oborony st., Kyiv, 03041Ukraine  
pankratova2105@gmail.com

<sup>2</sup> Kyiv National Economic University named after Vadym Hetman, Peremohy avenu 54/1, Kyiv 02000 Ukraine  
tpayentko109@gmail.com

<sup>1</sup> National University of Life and Environmental Science, 27 Heroiv Oborony st., Kyiv, 03041Ukraine  
zidfrih@gmail.com

**Abstract.** For successful trading on stock exchanges, it is important to use trading tools that will ensure success in trading operations and provide competitive advantages. The purpose of the article is to develop an algorithm for the creation of a trading system and selecting a research object whose shares may subsequently become the object of real trade. The basis of the developed trading system is the consolidated mathematical model based on several models (multipliers, neural network and discounted cash flows). The consolidated model estimates the stock price of NIKE Inc., which has a lower deviation from the actual price than the price is predicted by other mathematical models, including linear regression models, etc. The results of the work also identified directions for improving the trading algorithm: to extend the horizon of the forecast; to include TakeProfit at the predicted value; to form a stock portfolio; to cover more factors in the model.

**Keywords:** stock exchange, trading system, forecast, consolidated mathematical model.

## 1 Introduction

Nowadays forecasting is being considered as one of the most important branches of research in the economic and business fields and has been developing rapidly. Forecasting stock exchange prices by considering its dynamic factors is an important part of a business investment plan. The confidence of investors in these markets has declined and many negative problems in the world economy are present. This clearly shows the strong relationship between uncertainty in financial markets and investor confidence. Financial asset prices are influenced by numerous factors including peo-

ple behavior, political, economic, competition or other factors, so price forecasting can be a difficult process.

Due to the development of stock trading, opportunities to receive a stock investment return exist. However, this is possible only with a properly selected trading strategy and efficient trading system. Many traders diversify risks and increase profits using several types of trading systems, which number more than a thousand today. However, every trader or investor is trying to develop a unique trading system which will allow anybody to successfully invest money by trading stocks with a correct price forecast.

Forecasting prices allows not only individual financial asset price information to be considered, but also financial and economic systems, and financial crises to be assessed as to their possible scale in order to make appropriate economic decisions. At the same time, the lack of a unified theory that would explain price fluctuations in stock markets and a unified methodology for predicting prices for them determines the expediency and necessity of further development of the methodology of forecasting prices on stock exchanges.

The purpose of the article is to develop an algorithm for the creation of a trading system and selection of a research object whose shares may subsequently become the object of real trade. The paper is organized as follows. The next section explores the theoretical background of forecasting prices in stock exchange. The third part describes the methodology of the research. The fourth part is divided into three subsections. The first part analyzes the financial performance of the NIKE corporation and shows correlations between the economic and financial indicators of this corporation. The second part gives an assessment of the effectiveness of the developed forecasting model. In the third part the forecast of stock prices is made with the help of the developed model.

The study has several limitations. First is the time period for forecasting. Secondly, the testing was carried out using the shares of one corporation, not a portfolio, as an example. Thirdly, the TakeProfit was not included at the predicted value.

## **2 Theoretical Background**

Forecasting prices in stock markets is a matter of great interest both in the academic field and in business. The forecasting of stock prices and stock returns is possible using various techniques and methods. Many researchers study price trends in stock markets with the help of artificial neural networks [1-2] or fuzzy-trends [3, 4]. The application of artificial neural networks has become the most popular machine learning method, and it has been proven that such an approach can outperform most conventional methods. The most popular neural network algorithm for financial forecasting is the back-propagation algorithm. However, many articles have shown that the artificial neural networks model, based on the back-propagation algorithm, has some limitations in forecasting, and it can easily converge to the local minimum because of the noise and complex dimensionality of the stock market data.

Many researchers use time-series models or other types of regressions [5-7]. Stock market time series forecasting is an interesting and open research area. Artificial intelligence algorithms are now mostly used to forecast time series. However, a highly efficient stock exchange prediction model has not been designed yet.

Hybrid models have become more and more popular recently [8-9]. Kannan, Sekar, Sathik and P. Arumugam in [10] used data mining technology to discover the hidden patterns from the historic data that have probable predictive capability in their investment decisions. Usually, the rise or fall in an international stock market is caused by some external factors. This means that stock exchange forecasting depends upon local factors and international stock exchange markets. The robustness of forecasting models remains an open research area that creates many approaches to design trade systems for stock markets.

The trading system is based on a clear algorithm or, in other words, a clear set of rules for generating trade signals (that is, the conditions for opening or closing a position). The main difference between one trading system and another is its author's approach to the rules of trading signal generation [11]. Trading systems are based on one or a limited number of algorithms. Fundamental and technical analyses are used the most often in trading systems [12-15]. Also, genetic algorithms [16] and neural networks and neuro-fuzzy computing [17] have become popular too. However, as Kaufman mentioned, "most modeling methods are modifications of developments in econometrics and basic probability and statistical theory. They are precise because they are based entirely on numerical data; however, they need trading rules to make them operational. The proper assessment of the price trend is critical to most trading systems" [18, p. 6]. A trading system, in the process of its operation, requires constant debugging and analysis of completed transactions within a specified interval, changing parameters for the following operations in order to maximally optimize the intended trading strategy. Therefore, forecasting prices on the stock exchange with the help of trading system of a trader will be a wide area for future research for a long time.

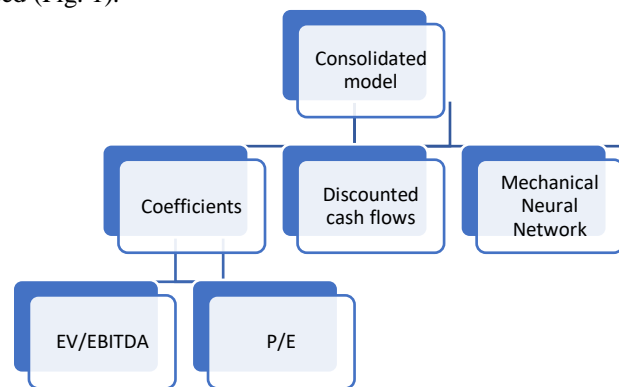
### **3 Methodology**

All trading systems operate according to their logic, that is, an algorithm that reports to the system how to behave in different situations. The algorithms of trading systems are developed based on the data obtained about events that previously occurred on the stock market. The algorithm of creating a trading system includes the following stages.

The first stage in the construction of a trading algorithm is the definition of a strategy that will achieve a desired goal. The rules that formulate the strategy should be set out consistently. The main rules are the rules surrounding entering and exiting markets, that is, the terms of purchase and sale of stock commodities. Typically, a trading strategy involves risk management by limiting the amount of risk capital. A typical approach is to install a stop loss order that limits the maximum damage that is allowed under the agreement. A trading strategy can also include revenue manage-

ment that protects the untapped profits generated during a lifetime position. A typical approach to managing long-run profits is to establish a retractable stop-loss for a fixed dollar value relative to the maximum of non-actualized profits. The purpose of our strategy is to verify the correctness of the forecast of prices, and not real bargains, so the stop-loss order was not used in our algorithm.

The best solution for the stock market is a strategy based on fundamental analysis, which involves an analysis of the work of business entities, as well as external market conditions. Two traditional forecasting models were used: Multiplier (M) and Discounted Cash Flow (DCF). These are classic models that do not require complex calculations or a large number of steps to calculate, although automation of calculations of these models will save several days. Since it is impossible to fully evaluate the effectiveness of stages such as testing or optimization, another model for forecasting stock market prices, the mechanical neural network (NN), which is based on economic indicators of the enterprise, was used. Thus, our consolidated model for predicting stock market prices (W) includes three models: multiplier, discounted cash flows and a mechanical neural network. For comparison, the traditional linear regression model (LM) is used (Fig. 1).



**Fig. 1.** Constituent methods of forecasting in the consolidated model

The second stage is to write an algorithm of action in the trading system in the programming language R, using C ++ to extract data, to automate all processes and calculations.

The third step in constructing the algorithm is testing the trading system. The testing stage has two goals: the first one is to determine if the system performs the specified functions; the second one is to check the possibility of obtaining profits and the risk of losses. The model should be moderately profitable with different price trends and over several different time periods. Not necessarily every test should show profit, but if each test is going to cause loss, then this system should be discarded.

Testing in various sectors of the economy has been used, which is necessary for the possibility of wider uses of the algorithm. For testing, the sample was limited to 10% of quarters, and at some periods of time it allows a better comparison of their reliability. Periods were chosen randomly, by the algorithm, but in a way that the trend of

stock quotes and indices was versatile (downward, growing, lateral). This is necessary for a better understanding of the efficiency of the algorithm in all types of market.

In the process of testing, an important step is to check the stability of the trading system. A robust trading system will provide profits across a wide range of variables, market segments, and market conditions. In other words, a sustainable model will continue to show profitable results and in changing market conditions, which is an extremely important result of trade. Thus, testing consists of two parts:

- 1) Selective manual check of various computer calculations of rules and formulas.
- 2) Investigation of the tested transactions and checking them for deviation from the theory.

The first trading system test is the calculation of profit and loss on a segment of price history of significant duration, for example, on an annual basis. This first test gives a preliminary idea of profit and risk. The main rule is to proceed from the expectations of annual profits at the level necessary for trading in this market.

The fourth stage of work is the choice of the subject of testing and the definition of the study period. The best market for research is the US stock market, as it is liquid and has a long history that is needed for analysis. The main criterion for selecting companies is the availability of electronic reporting and more than 20 years of quotations on the stock exchange. Seven companies were selected by sectors of the economy and their financial performance for 95 quarters (30.11.1994 - 30.08.2018) was analyzed. These are the following companies:

- 1) AT&T Inc. (technology);
- 2) WALMART Inc. (wholesale and retail trade);
- 3) ECOLAB Inc. (means for water, hygiene, health, etc.);
- 4) BIOGEN Inc. (health care)
- 5) WELLS FARGO & COMPANY (finance)
- 6) NIKE Inc. (consumer goods)
- 7) CATERPILLAR Inc. (production goods).

To demonstrate the results of the analysis, NIKE Inc. was selected. The company's revenue structure is simple in scope, but difficult in geography, that is, its financial performance is influenced not only by the situation in the US but also in the world.

The fifth stage is the optimization of the trading system, which is carried out on the same principles as testing, but the main task is to make the use of the trading system most effective. In a practical sense, optimization is a process of calculating the indicators of many different tests of this trading system on the same segment of price data. According to certain criteria, the best test results, which provide maximum profit potential in real trade, are selected, and they will be the basis for the optimization of the trading system. The object of optimization is the coefficient of reliability of the model, with which it is possible to achieve the best consolidated forecast.

The optimization has five components: (1) selection of model parameters; (2) setting the ranges of their scanning; (3) determination of the sample size; (4) determination of criteria for evaluation, selection of a better model; (5) determine the criteria for evaluating the test forecast as a whole. In the process of optimization, we should use the model parameters that have the most impact on its effectiveness. If the parameter has a small effect on efficiency, there are no reasons to make it a candidate for optimization. Instead, it should be assigned a fixed value (constant) for optimization time.

If optimization shows improved results, it is time to move to the final step of the testing process, namely, forward analysis. Forward analysis evaluates the effectiveness of the trading system solely on the basis of post-optimization trading or test data that are not part of the optimization sample. This level of testing answers two of the most important questions about our trading system: 1) the correctness of the forecast of prices 2) the possibility of profit after optimization.

The sixth stage is an assessment of the ratio of real trade indicators with projected indicators. If the real figures differ much from the test ones for no clear reasons, then a need to return to step number three is warranted.

The mathematical formalization of the processes embedded in the trading system algorithm and designations used in the study are as follows:

1. On the basis of the current financial report, forecasts are made for three models (NN, DCF, M)

2. The consolidated forecast price is based on formula (1):

$$\text{Pr\_Price} = \text{Knn} * \text{Pr\_NN} + \text{Kdcf} * \text{Pr\_DCF} + \text{Km} * \text{Pr\_M}, \quad (1)$$

Pr\_Price is the consolidated forecasted price,

K - coefficient of reliability of the model,

Pr\_ - forecasted price by model

NN - model of mechanical neural network,

DCF - Discounted Cash Flow Model

M - model of multipliers.

3. Determination of projected income by formula 2:

$$\text{Pr\_Prof} = | \text{Pr\_Price} - \text{Now\_Price} | / \text{Now\_Price}, \quad (2)$$

Pr\_Prof is a projected income,

Pr\_Price is the consolidated forecasted price,

Now\_Price is the actual current price.

4. The decision to enter the market based on the assessment of the appropriateness of investment, which is calculated by the formula 3:

$$\text{Pr\_Prof} - \text{Km-Slip} > \text{RF\_Rate} / 4, \quad (3)$$

Km - commission for the opening and closing of a position,

RF\_Rate - without a risky interest rate

Slip - slippage

RF\_Rate is a risk-free investment rate.

5. Closing a position on the day on which the forecast was made.

The concept of exit from the market implies the absence of StopLoss and TakeProfit, since the receipt of real profit is not the main goal, but only one of the indicators for checking the efficiency of the trading system. The main goal is to determine the price trend and price value for the planned closing date of the position.

Next, it is necessary to detail the information on one of the models, namely the model of the mechanical neural network, which entered the consolidated model and contains the largest number of economic indicators. Indicators that will be analyzed in

the neural network were selected based on the main indicators of financial reporting, namely:

From the report on financial results:

- 1) Rev (Revenue) - Revenue;
- 2) Inc (Net Income) - net profit;
- 3) Div (Dividends declared per share (in dollars per share)) - dividends on ordinary shares (in dollars per share).

From the balance:

- 1) Ast (Total assets) - aggregate assets;
- 2) Ldbt (Long-term debt) - long-term liabilities;
- 3) Sheq (Total shareholders' equity) - share capital;
- 4) Curl (Total current liabilities) - current liabilities.

From the Cash Flow Statement

- 1) Cash\_op (Cash provided by operations) - cash flow from operating activities;
- 2) Cash\_inv (Cash used by investing activities) - cash used in investment activities;
- 3) Cash\_fin (Cash used by financing activities) - cash flow used in financial activities.

Additional indicators were also used such as:

- 1) Price\_1 is a stock price at the time of the report's release;
- 2) S & P 500 is the stock index in which Nike is located;
- 3) Qw\_1 / 2/3/4 - quarters of the marketing year of Nike;
- 4) Price\_2 is a stock price for three days before payment of dividends for the forecasted quarter.

Additional indicators are needed to better understand the environment:

"Price\_1" is required for the neural network to be able to track the price change and understand what indicators have influenced it more,

"The S & P 500 Index" is needed to understand the situation in the economy and the US stock market.

Quarters as indicators needed to understand the cyclicity algorithm present in this market, as established by research. The above indicators are independent variables, the only dependent variable in this model will be Price\_2.

## **4 Efficiency Estimation Procedure**

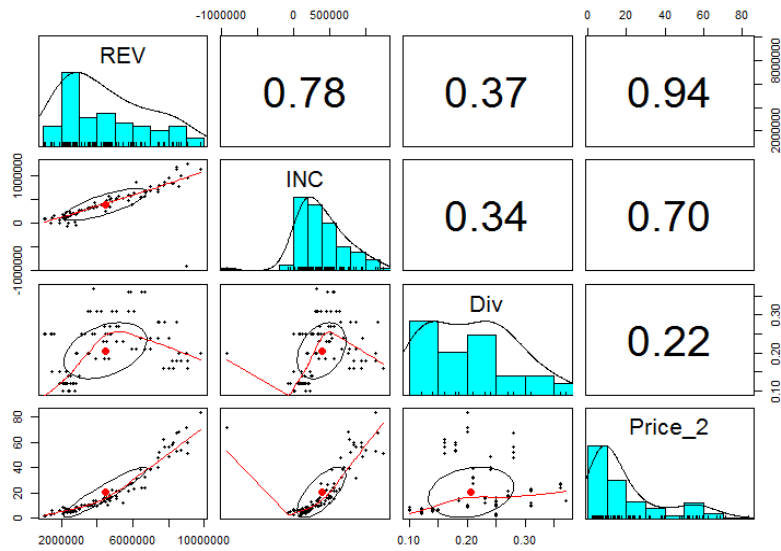
### **4.1 NIKE Inc. Financial and Economic Indicators Analysis**

According to the New York Stock Exchange (NYSE), the shares of the company grew more than 33 times (Figure 2) over the past twenty-four years, that is, the rate of growth - an average of 16% annually. However, the highest growth rates have been since 2009, when the company's products have gained popularity and spread around the world.



**Fig 2.** The price dynamics of NIKE Inc., 11.1994 - 03.2018, USD. US / share (Source:: NYSE)

Interaction of Financial Results Indicators with NIKE Inc. depicted in Fig. 3.



**Fig. 3.** Correlation coefficients, scatter plot, and distribution histogram between revenue, profit, dividends and share price of NIKE Inc.



Explanations to the figure 3:

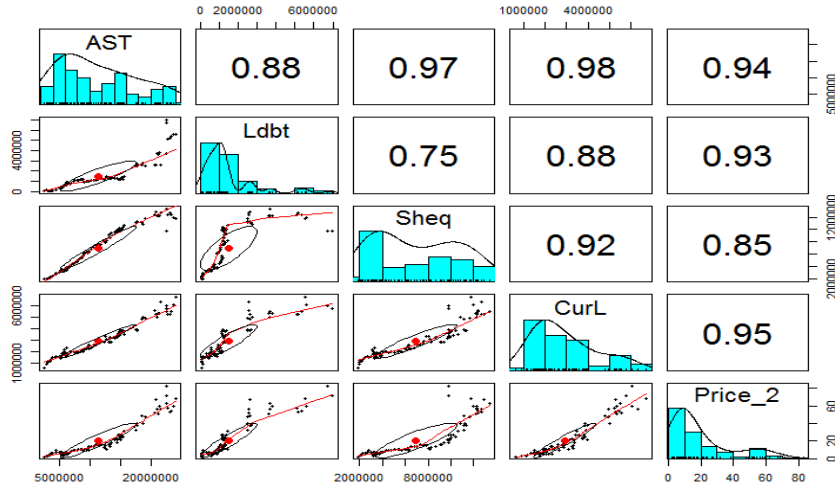
Revenue	Coefficient of correlation between revenue and profit	Correlation coefficient between revenue and dividends	Coefficient of correlation between revenue and price
Scatter plot between revenue and profit	Profit	Coefficient of correlation between profit and dividends	Coefficient of correlation between profit and price
Scatter plot between earnings and dividends	Scatter plot between profits and dividends	Dividends	Correlation coefficient between dividends and price
Scatter plot between revenue and price	Scatter plot between profit and price	Scatter plot between dividends and price	Price

As can be seen from the scatter plot, the revenues are positively interdependent with net profit and stock price, with the profit being a linear dependence of disproportionate growth. On the contrary, with the price of the stock, the interdependence is nonlinear, and the more accelerated rate of growth of prices from the growth of revenue. The net profit also correlates positively with the company's price, this dependence is also nonlinear and has hyperbolic acceleration function.

The Pearson correlation coefficients show that the largest share price correlates with income (0.94), less correlated with net profit (0.7) and has a slight correlation with dividends. In general, dividends moderately correlate with all indicators and are placed on the chart rather chaotic.

A distribution histogram is located on the central diagonal. Here it is necessary to note the full asymmetry on the right side (net profit and share price of the company) due to the long-term presence of the company in the medium-sized business, dividends and earnings are asymmetrical to the right, but they are more evenly arranged.

Next to be considered is how interrelated indicators balance with the predicted price in Figure 4. The aggregate assets have a strong proportional relationship with all the analyzed indicators; this is evident in the plot of scattering of the sample elements, as well as by the coefficient of correlation, which is higher than 0.8. Scattering in almost all cases is based on a linear function. There is a very interesting scatter plot between long-term capital and equity capital; initially the values take hyperbolic acceleration, then after 70% of the sample changes to the function of the hyperbolic cosine region, that is, the inverse hyperbola, which in our opinion is associated with an increase in the interest rate by the Fed of 2%. This influenced the decision on how to raise funds for financing the range; the absence of less costly loans prompted investors to find investors in the stock market.



**Fig. 4.** Correlation coefficients, scatter plot and histogram of distribution between assets, share capital, liabilities and share price of NIKE Inc.

Explanations to the figure 4:

Assets	Coefficient of correlation between assets and long-term liabilities	Coefficient of correlation between assets and equity	Correlation coefficient between assets and current liabilities	Coefficient of correlation between assets and price
Scatter plot between assets and long-term liabilities	Long-term liabilities	Coefficient of correlation between long-term liabilities and share capital	Coefficient of correlation between long-term liabilities and current liabilities	Coefficient of correlation between long-term obligations and price
Scattering Scale between Assets and Equity	Scatter plot between long-term liabilities and share capital	Equity	Correlation coefficient between share capital and current liabilities	Correlation coefficient between share capital and price
Scatter plot between assets and current liabilities	Scatter plot between long-term liabilities and current liabilities	Scatter plot between current liabilities and current liabilities	Current liabilities	Coefficient of correlation between current liabilities and price
Scatter plot between assets and price	Scatter plot between long-term obligations and price	Scatter plot between current liabilities and price	Scatter plot between current liabilities and price	Price

As in the figures in Figure 3, distribution histograms have right-side asymmetry (Figure 4), which indicate that the company is growing.

Spearman's correlation calculations (Figure 5) showed a close correlation between the price of a company's shares and independent variables, in particular the S & P 500 market index. This suggests that external factors are also influenced by the price of NIKE shares.

	REV	INC	Div	AST	Ldbt	Sheq	Curl	Price_1	S.P500	Cash_op	Cash_inv	Cash_fin	Price_2
REV	1.00	0.90	0.46	0.98	0.96	0.97	0.97	0.96	0.74	0.32	0.01	-0.38	0.95
INC	0.90	1.00	0.50	0.89	0.85	0.90	0.87	0.88	0.67	0.26	-0.06	-0.30	0.88
Div	0.46	0.50	1.00	0.47	0.43	0.50	0.46	0.45	0.13	0.22	0.01	-0.27	0.47
AST	0.98	0.89	0.47	1.00	0.97	0.98	0.98	0.96	0.76	0.38	-0.02	-0.40	0.95
Ldbt	0.96	0.85	0.43	0.97	1.00	0.95	0.94	0.93	0.73	0.40	-0.07	-0.40	0.92
Sheq	0.97	0.90	0.50	0.98	0.95	1.00	0.95	0.95	0.72	0.40	-0.06	-0.42	0.95
Curl	0.97	0.87	0.46	0.98	0.94	0.95	1.00	0.93	0.78	0.32	0.00	-0.35	0.93
Price_1	0.96	0.88	0.45	0.96	0.93	0.95	0.93	1.00	0.73	0.37	-0.04	-0.39	0.98
S.P500	0.74	0.67	0.13	0.76	0.73	0.72	0.78	0.73	1.00	0.32	0.02	-0.30	0.71
Cash_op	0.32	0.26	0.22	0.38	0.40	0.40	0.32	0.37	0.32	1.00	-0.25	-0.78	0.38
Cash_inv	0.01	-0.06	0.01	-0.02	-0.07	-0.06	0.00	-0.04	0.02	-0.25	1.00	-0.01	0.00
Cash_fin	-0.38	-0.30	-0.27	-0.40	-0.40	-0.42	-0.35	-0.39	-0.30	-0.78	-0.01	1.00	-0.40
Price_2	0.95	0.88	0.47	0.95	0.92	0.95	0.93	0.98	0.71	0.38	0.00	-0.40	1.00

Fig. 5. Spearman correlation coefficient between the investigated parameters

#### 4.2 Estimation of Efficiency of the Developed Model of the Forecast of Prices

One of the objectives of the study is to evaluate the effectiveness of the model, and one of the best methods of evaluation is a comparison with the traditional model. The classic method of forecasting, which is widely used in many spheres, is linear regression. Therefore, a regression model of stock price forecast was constructed.

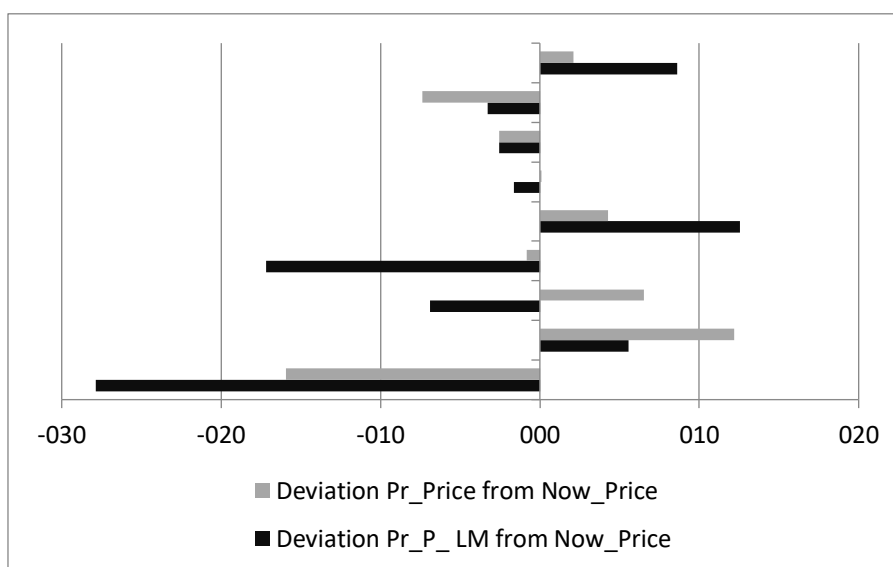
Further work was aimed at constructing, testing, optimizing, testing the reliability of the consolidated model, which included several models: neural, multiplicative and discounted cash flows with the help of computer equipment. In Table 1, projected prices for different models and the actual price at the end of the projection period can be compared. The date of forecasting is chosen independently by the program.

The final step in optimization is to determine the weight of each model in the consolidated forecast model, that is, at the forecasted price. The values of the mean-square deviation are as follows: for the neural network - 0,778; for multipliers - 0.134; for discounted cash flows - 0.088. This indicates the greatest impact of the neural model on the consolidated weighted price. This model, after optimization, gave the most accurate forecast.

**Table 1.** Actual and forecasted stock price figures for NIKE Inc. during test periods, US \$ / share

Data	Pr_P_NN	Pr_P_M	Pr_P_DCF	PR_P_LM	Pr_Price	Now_Price
31.05.2001	5,175	5,358	6,403	4,553	5,307	6,313
31.05.2002	6,186	6,555	8,241	6,036	6,416	5,719
28.02.2003	7,180	5,679	6,548	6,051	6,923	6,498
31.05.2007	13,366	12,797	14,820	11,208	13,417	13,53
30.11.2007	15,731	14,777	18,244	17,081	15,824	15,175
29.02.2008	16,753	13,561	15,816	15,965	16,243	16,23
30.11.2009	15,830	14,847	16,230	15,729	15,733	16,143
30.11.2010	20,236	21,092	21,269	21,346	20,442	22,073
30.11.2015	63,028	66,428	66,328	67,843	63,774	62,46

Figure 6 illustrates the deviation of the consolidated forecast price (Pr\_Price) and the price calculated by the linear model (Pr\_P\_LM) from the actual price (Now\_Price). As can be seen from Figure 6 and Table 1, the forecasted prices for the model we have developed are deviating less from the actual price line than the forecasted prices constructed according to the linear model, which indicates the undeniable advantages of the first model.



**Fig. 6.** Comparison of forecasted prices based on the consolidated model and the linear model with respect to actual prices for shares of NIKE Inc.,%.

A trading system based on a weighted model correctly identified the direction of price movement in 44% of cases, while 22% of trade signals differed from real price dynamics directly opposite, and 34% of trading signals differed slightly from the real

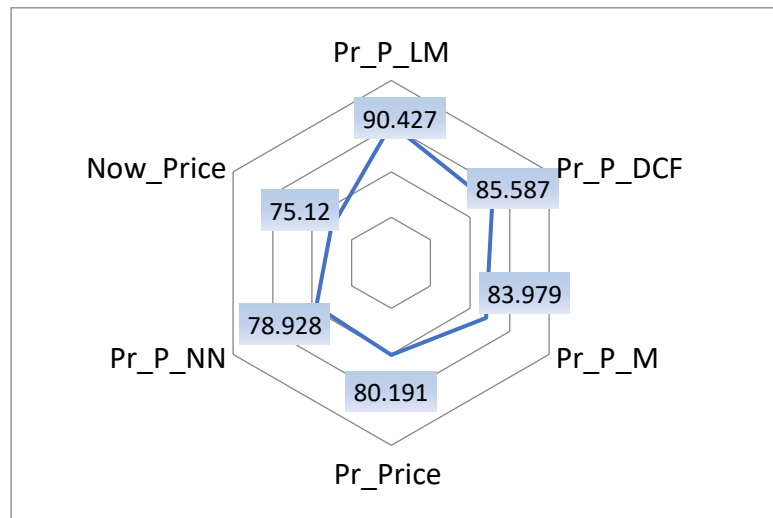
price movement. It should also be noted that 66% of the predicted values indicated the presence of a bear market, while the actual values in only 33% of observations in the next period showed a falling trend.

For comparison, the trading system based on a linear model correctly predicted the direction of prices only in 33% of the cases, another 33% of trading signals differed directly opposite from the real price dynamics, and the remaining 34% had a slight deviation from the real movement of prices. In one case, the trading system recommended not entering the market while during this period there was a bullish trend, so earnings opportunities would have been lost, and in two cases the system recommended taking a short position, when in fact the market during the quarter was in a side movement.

### 4.3 Forecast of Prices Using the Developed Trading Model

Since the testing did not give a precise assurance of the efficiency of the model, a forward test had to be carried out, that is, an analysis of the forecasted price within the actual time period that was not investigated nor considered. This is best done on the broker's demo account using the whole sample of data (95 quarters) to predict, not the 10% as used during testing.

For the forecast, a period was chosen that was not used in the model (31.08.2018-30.11.2018) and a quarterly forecast of stock prices of NIKE Inc. was made. (Figure 7, Table 2).



**Fig. 7.** Estimated price models and actual share price for NIKE Inc. as of 30.11.2018, USD US / share

**Table 2.** Comparison of NIKE Inc.'s forecasted price models and actual prices. as of 30.11.2018, USD US / share

Designation of models	Actual price (Now_price) (as of 31.08.2018)	Estimated price as of 30.11.2018	Actual price (Now_price) as of 30.11.2018	Rejection of projected prices from actual
Pr_P_DCF	82,20	85,59	75,12	10,47
Pr_P_M	82,20	83,98	75,12	8,86
Pr_P_NN	82,20	78,93	75,12	3,81
Pr_Price	82,20	80,19	75,12	5,07
Pr_P_LM	82,20	90,43	75,12	15,31

Thus, the biggest difference between the forecast and actual price as calculated based on linear regression model was \$15.31 per share. The smallest deviation from the projected price from the actual demonstration was the model based on the neural network at \$3.81 per share. This model has the greatest impact on the consolidated weighted price, so the deviation from the actual price was \$5.07 per share.

Both the neural network model and the consolidated model predicted lower prices at the end of the examined quarters than at the beginning. However, all other models predicted a bullish trend, which proved to be false. The joint impact of model multipliers (M) and the discounted cash flow model (DCF) had a negligible effect on the consolidated model.

During the period in which the forward analysis was conducted there were no significant changes in the company's policy nor strategy, and the projected figures for the following year were not revised. However, there was a negative marketing impact when the company's major advertising face, Cristiano Ronaldo, was accused of personal income tax evasion. This news alone could have provoked a downward trend in prices that we could predict using a trading system based on our consolidated model, which showed better results than the linear regression model, and the two models, neural network and discounted cash flows, which had been tested separately

## 5 Conclusions

Consequently, the created trading algorithm is capable of allowing predictions to be made of the company's share price with a fairly high accuracy using the consolidated model. The largest influence on the company's share price is made by indicators such as revenue, net profit and aggregate assets for which the correlation coefficient is more than 0.95. The company has a sound dividend policy, so dividend changes have little effect on price dynamics.

The results of the work also identified directions for improving the trading algorithm.

1) In further research, we plan to extend the horizon of the forecast, as the stock market is one of the best environments for long-term investment. It will also simplify the calculations, namely, deviating from the analysis of quarterly indicators to annual.

2) In many cases, test tests, if we put TakeProfit at the predicted value, we could profit before, and sometimes even avoid losses. Therefore, in the future, we plan on using two models to determine the expediency of buying shares, and the neural network to determine when it is best to buy or sell shares.

3) In order to diversify risks, it is expedient to use not only shares of one company for forecasting but also to form a stock portfolio for investing funds.

4) The broader coverage of the fundamental factors that will be included in the model for analysis will only improve the results of the work.

Improving the trading system will allow more accurate forecasts and, accordingly, more effective investments in the stock market.

## References

1. Strzelchuk, A., Strzelchuk, Ar.: Trends in the stock market and their price forecasting using artificial neural networks, *Central and Eastern European Journal of Management and Economics* Vol. 1, No. 2, 155-164 (2013).
2. Lin, Y., Guo, H., Hu, J.: An SVM-based approach for stock market trend prediction. In *Proceedings of the 2013 International Joint Conference on Neural Networks (IJCNN)*, Dallas, TX, USA, 4–9 August 2013; IEEE: Piscataway, NJ, USA (2013).
3. Guan, H., Dai, Z., Zhao, A., He, J.: A novel stock forecasting model based on high-order-fuzzy-fluctuation trends and back propagation neural network. *PLoS ONE* 13 (2018).
4. Kodogiannis, V., Lolis, A.: Forecasting financial time series using neural network and fuzzy system-based techniques. *Neural Comput. Appl.* 11, 90–102 (2002).
5. Gong, X., Si, Y.-W., Fong, S.: Biuk-Aghai, R.P. Financial time series pattern matching with extended UCR Suite and Support Vector Machine. *Expert Syst. Appl*, 55, 284–296 (2016).
6. Wen, Q., Yang, Z., Song, Y.: Jia, P. Automatic stock decision support system based on box theory and SVM algorithm. *Expert Syst. Appl*, 37, 1015–1022 (2010).
7. Wang, L., Wang, Z., Zhao, S., Tan, S.: Stock market trend prediction using dynamical Bayesian factor graph. *Expert Syst. Appl*, 42, 6267–6275 (2015).
8. Huang, C.-F.: A hybrid stock selection model using genetic algorithms and support vector regression. *Appl. Soft Comput*, 12, 807–818 (2012).
9. Chiang, W.-C., Enke, D., Wu, T., Wang, R.: An adaptive stock index trading decision support system. *Expert Syst. Appl*, 59, 195–207 (2016).
10. Kannan, K.S., Sekar, S., Sathik M. M. and Arumugam, P.: Financial stock market forecast using data mining Techniques, *Proceedings of the international multiconference of engineers and computer scientists* (2010).
11. Leigh, W., Hightower, R. and Modani, N.: Forecasting the New York Stock Exchange Composite Index with Past Price and Interest Rate on Condition of Volume Spike, *Expert Systems with Applications*, Vol 28, pp. 1-8 (2005).
12. Tseng, K.-C., Kwon, O., and Tjung, L.C.: Time Series and Neural Network Forecast of Daily Stock Prices, *Investment Management and Financial Innovations*, Vol 9, No 1, pp 32-54 (2012).
13. Klassen, M.: Investigation of some technical indexes in stock forecasting using neural network. *Proceedings of World Academic of Science, Engineering and Technology* 5:75-79 (2005).

14. Reznik N. and Pankratova L.: High-Frequency Trade as a Component of Algorithmic Trading: Market Consequences. CEUR Workshop Proceedings, vol. 2104, P. 78-83.. Available: <http://ceur-ws.org/Vol-2104> (2018).
15. Westerhoff, F. H.: Multi-Asset Market Dynamics, *Macroeconomic Dynamics*, 8/2011, pp. 596—616 (2011).
16. Thompson, J.R., Wilson J.R. and Fitts, E. P.: Analysis of market returns using multifractal time series and agent-based simulation, *Proceedings of the Winter Simulation Conference (WSC '12)*. Winter Simulation Conference, Article 323 (2012).
17. Lento, C.: A Combined Signal Approach to Technical Analysis on the S&P 500, *Journal of Business & Economics Research*, 6 (8), pp. 41–51 (2008).
18. Vezeris, D., Kyrgos T. and Schinas Ch.: Take Profit and Stop Loss Trading Strategies Comparison in Combination with an MACD Trading System *J. Risk Financial Manag.* 11, 56, 2-23. doi:10.3390/jrfm11030056 (2008).
19. Mendes, L., Godinho P. and Dias, J.: A Forex trading system based on a genetic algorithm, *Journal of Heuristics* 18 (4), pp. 627-656 (2012).
20. Badawy, O. and Almotwaly, A.: Combining neural network knowledge in a mobile collaborating multi-agent system, *Electrical, Electronic and Computer Engineering, ICEEC '04*, pp. 325, 328, DOI: 10.1109/ICEEC.2004.1374457 (2004).
21. Kaufman, P. J.: *Trading systems and methods* / Perry J. Kaufman. — 5th ed (2013).



# The Relationship between Oil and Gas Prices, Dow Jones and US Dollar Indexes: A Wavelet Co-movement Estimation and Neural Network Forecasting

Olena Liashenko<sup>1</sup>, Tetyana Kravets<sup>1</sup>

<sup>1</sup> Taras Shevchenko National University of Kyiv

lyashenko@univ.kiev.ua, tankravets@univ.kiev.ua

**Abstract.** In this study, we consider the relationship between oil and gas prices, the Dow Jones index, the US dollar index and their volatility indicators. Application of wavelet analysis allows to reveal regularities of dynamics of selected time series at different periods. The Wavelet approach makes it possible to determine how these variables interact at different frequencies, and how this interaction evolves over time on different frequency scales. Common revenue movements of the studied time series characterize the behavior of the relevant markets. The levels of high volatility at similar intervals explain that there is a link between the changes in these markets, and the global economy is vulnerable to oil and gas prices, the value of the dollar index and the Dow Jones index. At the next stage of the research, a comparison of the predictive capabilities of Long Short Term Memory and Wavelet based Back Propagation neural networks for co-movement leaders is made.

**Keywords:** wavelet analysis, wavelet coherence, wavelet multiple correlation and cross correlation, neural networks, volatility.

## 1 Introduction

The global financial system combines various assets traded in markets. These markets have characteristics that lead to different types of volatility. Asset prices react to each other in many respects. Market participants operate at different time scales, depending on their requirements, and, therefore, the true dynamic structure of the relationship between variables can vary at different time scales. Looking at this phenomenon in terms of portfolio diversification, one can say that market participants with short-term investment horizons are active at higher frequencies, and those with long-term investment horizons operate on a longer scale. Therefore, it is necessary to analyze co-movements in the markets on several scales. Wavelet methods provide a large-scale data analysis naturally [1].

The growing interest in wavelet analysis among economic researchers and its applicability in such areas as time decomposition, forecasting and density estimation led to the emergence of various wavelet techniques for analyzing nonstationary

financial time series [2]. The wavelet approach is ideally suited for studying high-frequency data generated by financial markets, providing valuable information for decision-making, as an analyst can focus on a certain amount of time when trade patterns are considered important. Thus, wavelet technique has enormous potential in economics and finances, since the relationships between different variables can be analyzed in time-frequency space. It allows to research the interconnections between variables at different frequencies and the corresponding information on the evolution of a variable in time simultaneously.

Continuous wavelet transform is a promising method for analyzing the joint movement of stock prices in different countries, since this technique can illustrate the value of the share price ratio between two different markets in time-frequency space. It follows that the trend in the stock returns co-movement can be divided into short, medium and long-term horizons, which serve as an important benchmark for investors to make investment decisions in the short, medium and long term, respectively.

The purpose of the paper is to study the dynamics of oil and gas prices, Dow Jones and US dollar indexes, and to identify co-movements in relevant markets in time and frequency domains. Using wavelet methodologies, pair coherence and multiple correlation of time series returns were studied in order to determine co-movements leaders at the appropriate frequency and time scales. For these leaders, the prognostic capabilities of the Long Short Term Memory (LSTM) and Wavelet based Back Propagation (WBP) neural networks were compared.

## **2 Analysis of Recent Research**

Over the past decades, many studies have examined the interconnection between different economic variables in different markets. Rua and Nunes [3] suggested using a continuous wavelet analysis to evaluate the co-movement of stock prices on international stock markets. Following the methodology of Rua and Nunes, the co-movement of various economic variables on different stock markets has been studied in many studies [4-6]. Distribution of profits in various energy markets was considered in [7]; the relationship between oil prices and the exchange rate was studied in [8]; the ratio between the price of oil and the price of shares was investigated in [9].

It is worth noting that there are also many works that use discrete wavelet analysis to detect the interconnections between different economic variables in different countries. The discrete wavelet analysis was first proposed by Ramsey and Lampast [10] to study the relationship between income and other macroeconomic variables. This technique has become very popular in applied economics since Gencay, Selcuk, Whitcher [11] and Percival, Walden [12] presented details of the discrete wavelet method for analyzing time series [13]. According to this methodology, the relationship between different economic variables, such as the co-movement of profits in different stock markets [14, 15], the co-movement of long-term interest rates between European countries [16] was investigated. The global relationship between

the Dow Jones Industrial Average and the US industrial index is analyzed by Gallegati [17] using wavelet correlation and cross-correlation methods.

In [18], using a wavelet approach, the relationship between four basic assets simultaneously (oil, gold, currency and stocks), between the four fear indices (OVX, GVZ, EVZ and VIX) and the link between all assets for detection of co-movement in the world financial markets. In [19] authors state that oil is now the most important source of energy. Any sharp drop in its prices will have beneficial effects on the US dollar and mainly for the economic competitiveness of countries that are not large oil producers, and vice versa.

As companies operating in oil, gold and forex markets sell their stocks on the stock market, one can expect stocks to represent the most important of these four assets. They are the key factors in asset allocation and, therefore, are most sensitive to global shocks [20-22].

All of the above studies are an example of the relationship between underlying assets and total volatility indices in the time domain. However, what promises the simultaneous region and area frequency (wavelet analysis) in this area of research, you can make the analysis of the co-movement more complex and useful to investors. It is expected that oil and US dollar prices will be more prone to external shocks due to the specific features of their markets, which are heavily dependent on policy interference through energy and monetary policy, to which extent these markets react to each other and the feedback between gold and stocks are even complex and fuzzy [23-24].

Unpredictable stock market factors make stock futures forecasting more complicated. Although the efforts in an effective prediction method developing have a long history, recent advances in the field of artificial intelligence and the use of artificial neural networks have increased success in a nonlinear approximation. In [25], it is suggested to use a combination of a futures forecasting model based on a stock index using neural networks of deep learning (an automatic encoder and a limited Boltzmann machine).

### 3 Research Methods

Wavelet technics based on discrete wavelet transform (DWT) and continuous wavelet transform (CWT) are used to study interconnections and interactions between time series. CWT is used to determine the wavelet power spectrum of a signal and wavelet coherence of two signals. DWT is used to compute the multiple wavelet correlation and multiple cross-wavelet correlation of time series.

The wavelet function  $\psi(t)$  is a local function, both in time and in frequency, and it is defined as:

$$\psi_{\tau,s}(t) = \frac{1}{\sqrt{|s|}} \psi\left(\frac{t-\tau}{s}\right), \quad s, \tau \in R, s \neq 0,$$

where  $s$  – scale factor that controls the width of the wavelet,  $\tau$  – time interval. The wavelet function must satisfy the admissibility conditions [12, 26-27].

CWT for time series  $x(t)$  is defined as:  $W_x(\tau, s) = \frac{1}{\sqrt{|s|}} \int_{-\infty}^{+\infty} x(t) \psi^* \left( \frac{t-\tau}{s} \right) dt$ .

The Wavelet Power Spectrum (WPS) provides information about the local variance of time series at each frequency. WPS describes how the time series  $x(t)$  varies over the selected scale and at the selected time point. WPS is defined as the square of the absolute value of CWT:

$$WPS_x(\tau, s) = |W_x(\tau, s)|^2.$$

Wavelet Coherence (WC) is a powerful tool for describing the interaction between two time series and studying their co-movements in common time and frequency domains. The first step in removing the WC is the cross-wavelet transform (CRWT) calculation. CRWT of two time series  $x(t)$  and  $y(t)$  is defined as follows:

$$W_{xy}(\tau, s) = W_x(\tau, s) W_y^*(\tau, s),$$

where  $W_x$  and  $W_y$  – CWT of time series  $x(t)$  and  $y(t)$  respectively, and the symbol  $*$  denotes complex conjugation.

In this case, the cross-wavelet power (CWP) is determined as follows:

$$CWP_{xy} = |W_{xy}(\tau, s)|.$$

By defining CRWT and CWP, one can enter square wavelet coherence (SWC):

$$R_{xy}^2(\tau, s) = \frac{|S(s^{-1} W_{xy}(\tau, s))|^2}{S(s^{-1} |W_x(\tau, s)|^2) S(s^{-1} |W_y(\tau, s)|^2)},$$

where  $S$  - smoothing operator.

The wavelet coherence coefficient varies between 0 and 1, and it can be considered as the square of the local correlation coefficient between two time series. A greater value of this coefficient indicates a stronger relationship between the time series [11, 13, 24].

SWC is not able to distinguish between positive and negative correlations and to determine the relationship between two time series. For this reason, the wavelet-coherence phase difference was introduced [15]:

$$\varphi_{xy}(\tau, s) = \text{tang}^{-1} \left( \frac{\Im \{ S(s^{-1} W_{xy}(\tau, s)) \}}{\Re \{ S(s^{-1} W_{xy}(\tau, s)) \}} \right),$$

where  $\Im$  and  $\Re$  are imaginary and valid operators, respectively.

Arrows on the wavelet coherence figures represent the phase difference. Following the trigonometric convention the direction of arrows shows the relative phasing of time series and can be interpreted as indicating a lead/lag relationship. If the arrows point to the right (left), the time series are in-phase (anti-phase), i.e. they are positively or negatively correlated, respectively. If the arrows point up and right (left), this indicates that the study series are in-phase (anti-phase) and the first (second) time series leads the second (first) one. A zero phase indicates that two series move together [13].

In contrast to the two-dimensional analysis, the multiple wavelet correlation (WMC), developed by Fernandez and Macho [14], allows us to determine the general correlation that can exist at different time scales within a multivariable set of variables. WMC is defined as a single set of multivalued correlations calculated from a multivariate stochastic process  $X_t = (x_{1t}, x_{2t}, \dots, x_{nt})$ . The wavelet coefficients of  $j$  level  $(W_{j,t})$  and scaling coefficients  $(V_{j,t})$  will be obtained for the maximum overlap DWT (MODWT) method. In each scale  $\lambda_j$ , WMC  $\{\varphi_x(\lambda_j)\}$  is calculated as the square root of the regression determination coefficient in such a linear combination of wavelet coefficients  $W_{jt} = (w_{1jt}, w_{2jt}, \dots, w_{njt})$  for which the determination coefficient is the maximum.

The WMC coefficient can be expressed as wavelet dispersion and covariance:

$$\varphi_x(\lambda_j) = \text{Corr}(w_{ijt}, \bar{w}_{ijt}) = \frac{\text{Cov}(w_{ijt}, \bar{w}_{ijt})}{\sqrt{\text{Var}(w_{ijt}) \text{Var}(\bar{w}_{ijt})}},$$

where  $w_{ijt}$  is chosen for maximum increase  $\varphi_x(\lambda_j)$ , and  $\bar{w}_{ijt}$  denotes fitted values in the regression of  $w_{ijt}$  on the rest of the wavelet coefficients on the scale  $\lambda_j$ .

Similarly, allowing a lag between observed and fitted values at each scale  $\lambda_j$ , the WMCC is defined as follows:

$$\varphi_{x,k}(\lambda_j) = \text{Corr}(w_{ijt}, \bar{w}_{ijt+k}) = \frac{\text{Cov}(w_{ijt}, \bar{w}_{ijt+k})}{\sqrt{\text{Var}(w_{ijt}) \text{Var}(\bar{w}_{ijt+k})}},$$

where  $k$  is a lag between observed and fitted values of the variable selected as the criterion variable at each scale  $\lambda_j$ .

The consistent estimator for the wavelet multiple correlation (denoted by  $\tilde{\varphi}_x(\lambda_j)$ ) and consistent wavelet multiple cross correlation estimator (denoted by  $\tilde{\varphi}_{x,k}(\lambda_j)$ ) can be constructed in the same way by substituting  $\varphi_x(\lambda_j)$  for  $\tilde{\varphi}_x(\lambda_j)$  and  $\varphi_{x,k}(\lambda_j)$  for  $\tilde{\varphi}_{x,k}(\lambda_j)$  [14, 28].

The idea of recurrent neural networks (RNN) is to use sequential information. In the traditional neural network, we assume that all inputs are independent of each other. But for many tasks, this is not an optimal idea. RNN are called recursive because they perform the same task for each sequence element, with initial data dependent on previous calculations. Recurrent neural networks have a "memory" that captures information about what was calculated by this time [29-31].

The Long Short Term Memory (LSTM) networks are a special type of RNN that can study long-term dependencies. All RNN have the form of a chain of repetitive neural network modules. In a standard RNN, this repeating module has a simple structure of one layer. LSTM also has such a chain structure, but the repeating module

has four layers. A RNN can be considered as multiple copies of one network, each of which sends a message to the next one.

The back propagation (BP) neural network is an artificial intelligence algorithm widely used in prediction, in particular for advanced multiple regression analysis. It better generates complex and non-linear responses than a standard regression analysis [32]. A BP network uses the gradient method, and the learning and inertial factors are determined by experience. This affects the convergence in a BP network.

The Wavelet-based BP method uses both a wavelet-based multi-resolution analysis and multi-layer artificial neural networks. The DWT allows decomposing sequences of past data in subsequences (named coefficients) according to different frequency domains, while preserving their temporal characteristics [33].

To assess the accuracy of forecasting, two criteria are used: mean square error (RMSE), average absolute percentage error (MAPE).

$$RMSE = \sqrt{\frac{\sum_{t=1}^N (\bar{y}_t - y_t)^2}{N}},$$

where  $y_t$  and  $\bar{y}_t$  - the actual value and the predicted value at time  $t$ , respectively,  $N$  - the size of the data set. RMSE expresses the standard deviation of the difference between predicted and actual values.

MAPE, also known as the average absolute deviation percentage (MAPD), expresses accuracy in percentages:

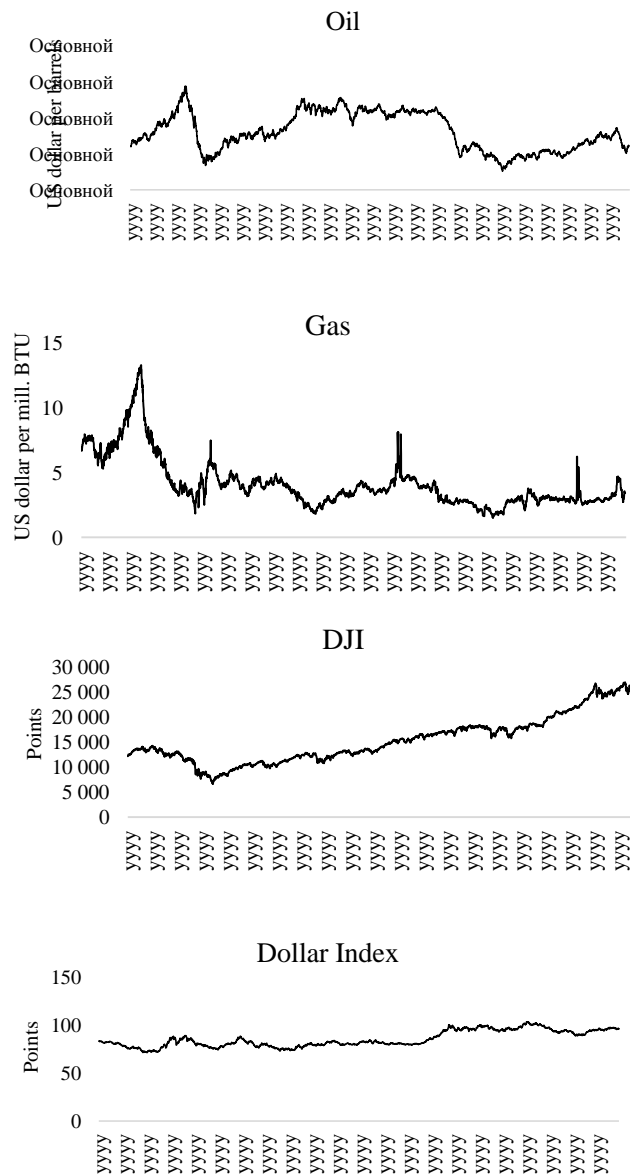
$$MAPE = \frac{1}{N} \sum_{t=1}^N \left| \frac{y_t - \bar{y}_t}{y_t} \right|.$$

MAPE measures the average absolute relative error of forecasting. RMSE and MAPE are widely used to estimate predictive accuracy. The accuracy of the model is higher when the value of RMSE and MAPE are lower.

## 4 Research results

To study the relationship that causes correlations between the oil and gas market, the Dow Jones index and the US dollar index, we used Brent crude oil prices, Henry Hub gas prices, and the Dow Jones index and the US dollar index respectively. The data set consists of daily figures for the period from September 2007 to January 22, 2019. This interval was chosen based on the fact that it covers the main fluctuations in selected markets. Fig. 1 shows the dynamics of prices and indices. We can see that, for some times, series tend to have the same trend, and in other periods, they are different. For example, from 2007 to 2008, unlike the oil and gas market, where this period was characterized by rising prices, we see a decline in the US dollar index and the relative stability of the Dow Jones index. Between 2008 and 2009 there was a sharp fall in prices on oil and gas markets and a drop in the Dow Jones index. At the same time, the US dollar index was stable for the first half of the year and then increased. In 2014-2015, the US dollar index was growing fast, the Dow Jones index was slower of it but also growing, unlike oil and gas prices that were falling. Only the

Dow Jones Index from 2009 to 2018 had a pronounced rising trend, other series were more volatile.



**Fig. 1.** Dynamics of time series

Descriptive statistics of time series logarithmic returns are given in Table 1. The available average standard deviation ranges from 0.5% to 4.2%, the most volatile time series is gas price, and the US dollar index is the least volatile. In addition, the

statistics of Pearson categorically rejects the null hypothesis, which assumes that the distribution of returns is normal.

**Table 1.** Descriptive statistics of time series returns

	Oil	Gas	Dow Jones index	US dollar index
Average value	2.65E-06	-2.44E-04	2.33E-04	4.89E-05
Standard deviation	0.022	0.042	0.012	0.005
Skewness	0.131	0.688	-0.136	-0.009
Kurtosis	5.554	26.077	10.066	2.156
Pearson's statistics	687.930	1871.100	2313.800	5786.500

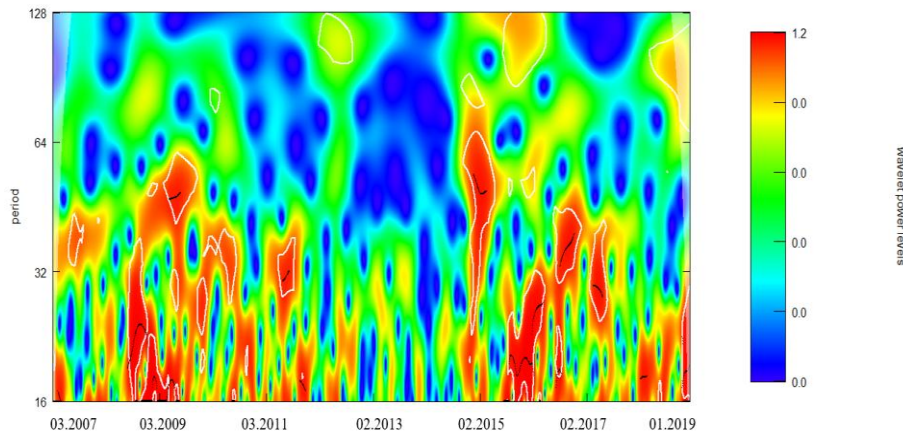
In order to study the interconnections between markets, wavelet analysis is further used. The calculations were carried out in the RStudio program environment. Morlet's mother wavelet with six levels of decomposition was used. Fig. 2 shows a wavelet power spectrum for the oil market at different time scales. Three cycles were chosen to construct the wavelet power spectrum. The first and second cycles on the middle scales are 16-32 days (monthly scale) and 32-64 days (from monthly to quarterly scale). The third cycle on a scale of 64-128 days (from a quarterly to annual scale) refers to a long-term analysis. These periods are deferred on the vertical axis of the graph, the time is indicated on the horizontal axis. The wavelet power is indicated by the color ranging from red to blue, which corresponds to regions of high and low power respectively. White contours indicate a 5% significance level. "Cone of influence", where boundary effects become important, is shown with a lighter shade. Black lines indicate power peaks. There are two distinct regions with high volatility with white circles at medium scales (16-32 days) in the end of 2008 and the beginning of 2016. The available peaks of power are due to the global crisis and the sharp drop in prices on the world market, respectively. One can also observe the high power region at the beginning of 2015 at medium scale (32-64 days). It can be explained by the long fall in oil prices when they have reached its historic minimum.

The spectrums of gas prices, the Dow Jones index and the US dollar index have regions of high power at medium scales (16-32 days, 32-64 days) in the end of 2008. Also, periods with high volatility of gas prices are observed at the same scales in 2016-2017. For the Dow Jones and US Dollar index, similar regions are in 2011, 2015, and the end of 2018.

The next stage of the study is the calculation of wavelet coherence for the logarithmic returns of time series. Graphs of spectra are constructed in the same way: time and period are marked on the axes. In this case, more periods were included, namely: 2-4 days (intra-week scale), 4-8 days (weekly scale), 8-16 days (two-week scale), 16-32 days (monthly scale), 32-64 days (from monthly to quarterly scale), 64-128 days (from quarterly to two-quarter scale), 128-256 days (from two to three



quarterly scale) and 256-512 days (annual scale). The arrows indicate the phase difference between the two time series.



**Fig. 2.** Wavelet power spectrum of oil market

Figs. 3-5 shows the degree of similarity and phase relationships between the logarithmic returns of oil and gas prices, oil prices and the US dollar index, oil prices, and the Dow Jones index respectively.

The coherence between the returns of oil and gas prices (Fig. 3) is strong at high scales (128-256 days, 256-512 days). Several "islands" of high coherence can be identified at medium scales in 2008, 2012 and 2015-2017. At the same time, in most cases, the direction of the arrows indicates that changes in oil prices lead to changes in the gas market, that is, the oil prices are leading.

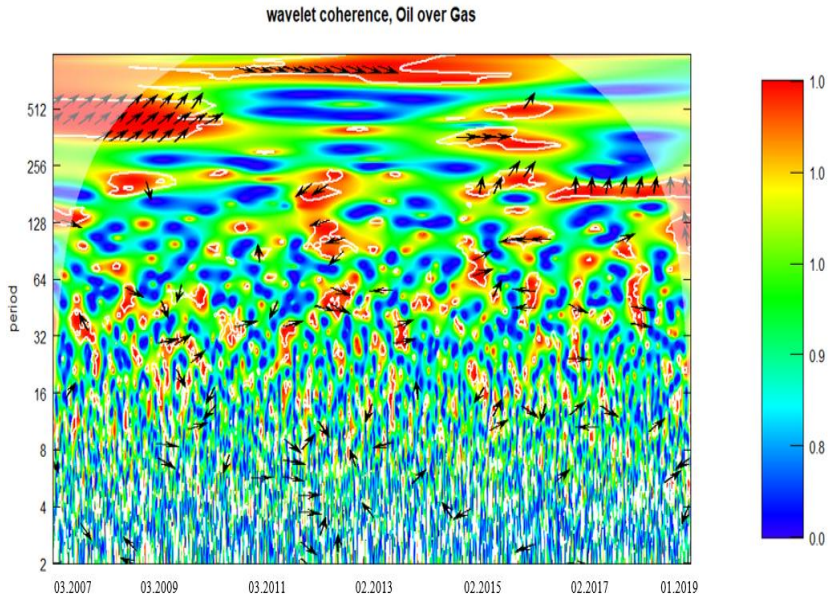
Fig. 4 shows the wavelet coherence between the returns of oil and the US dollar index. One can see the similar picture, but in this case, the series are in the antiphase. That is, the volatility of the US dollar index causes changes in the oil market. At low scales, the correlation is weak, strong correlation periods are observed in 2008 and over the period 2015-2017 at medium and high scales.

Analyzing the coherence between the returns of the oil prices and the Dow Jones index (Fig. 5), we can say that fluctuations in oil prices affect the volatility of the Dow Jones index, that is, the series correlate positively. Three high-coherence periods can be distinguished: 2008, mid-2011 and 2016 at medium and high scales. At low scales, the correlation is small.

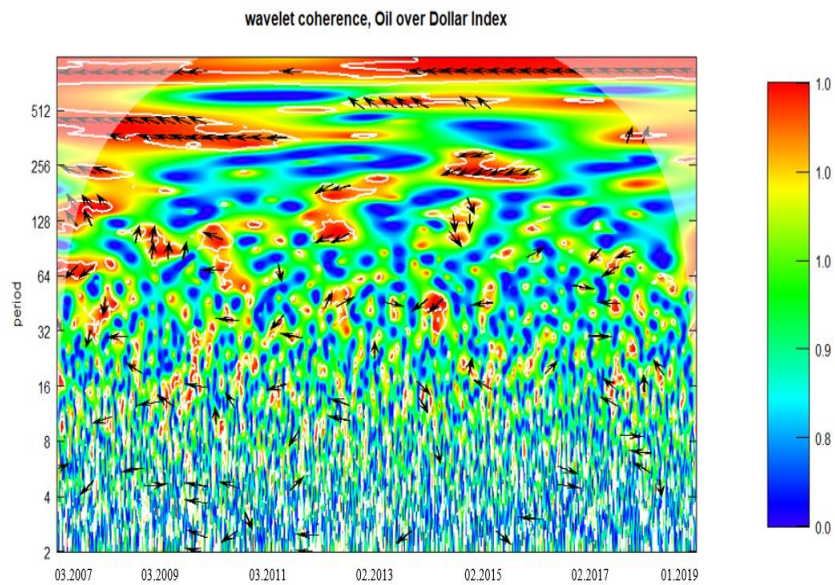
Interaction of the time series of gas prices and the US dollar index is weak at low and medium scales, but significant at high one. There is a period of high coherence in the period 2008-2009. In this case, the arrows are mainly directed upwards and to the left. It indicates the two series are in antiphase. The US dollar index is a leading series, its volatility affects the gas market.

The correlation between returns of gas prices and the Dow Jones index is similar: it is negligible or absent at all low scales, but strong at medium and high. There is a

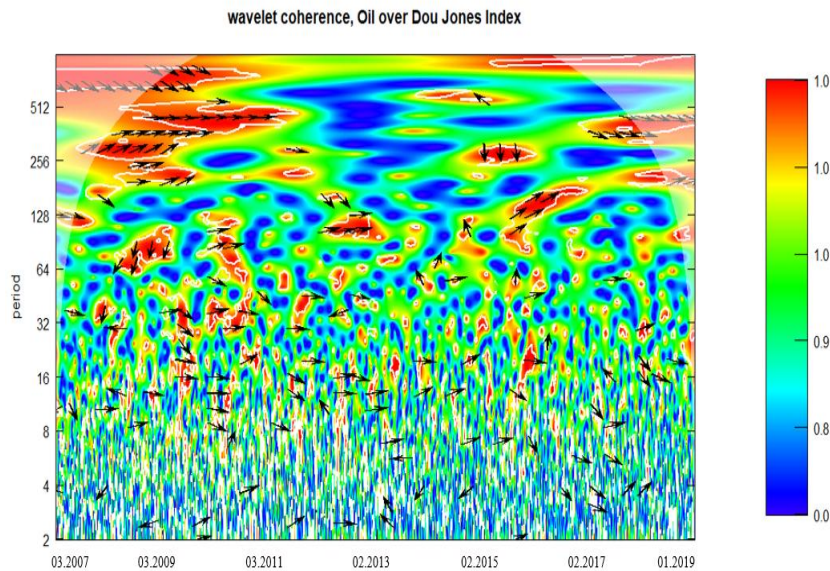
marked area of high coherence at high scales in 2008. It is interesting, the gas market is leading at medium scales, and the Dow Jones index is leading at high ones.



**Fig. 3.** Wavelet coherence between returns of oil and gas prices



**Fig. 4.** Wavelet coherence between returns of oil price and the US dollar index



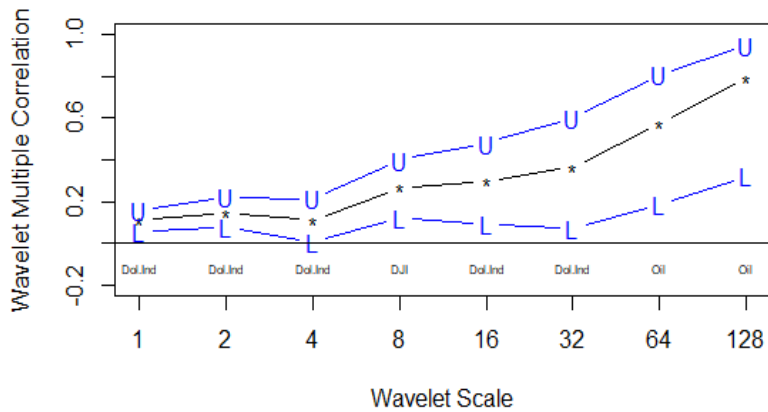
**Fig. 5.** Wavelet coherence between returns of oil price and the Dow Jones index

At medium and high scales, the returns of the US dollar index and the Dow Jones index are both in antiphase (the arrows are mostly directed to the left). It means that the second series is the lead. There is a pronounced period of high coherence at medium and high scales in 2008. At low scales, the correlation is small or absent.

So, comparing the obtained results, we can say that high coherence is observed in both crisis and non-crisis periods. The highest coherence of the series returns is marked at medium and high scales during 2008. In most cases, at these scales, oil prices and the US dollar index, gas prices and the US dollar index, as well as the US dollar and Dow Jones indexes, move in the antiphase. However, there are periods with a bidirectional relationship between the series at the medium and high scales. At the same time, the oil market leads the gas market. The US dollar index influences (is leading) the formation of oil and gas prices. In turn, oil prices affect the value of the Dow Jones index.

The wavelet multiple correlation was obtained for the different groups of time series. Fig. 6 presents the wavelet multiple correlation for all four markets together. On a horizontal axis, the 8 decomposition levels by the Daubechies(4) wavelet are plotted. On the vertical axis, the wavelet multiple correlation coefficient is marked. The blue lines show the upper and lower limits of the 95% confidence interval. The black line connects the value of the multiple correlation between the given time series at a certain scale. Below there is indicated what market is leading for a certain period. At medium scales (32-64 days, 64-128 days) the US dollar index is ahead, at high scales (128-256 days, 256-512 days) the oil market is leading. At high scales, co-

movement is almost linear; the multiple correlation reaches a value of about 0.9. We can conclude that the combination of financial (gas and oil market) and stock markets (the Dow Jones Index and the US dollar index) makes them more integrated.



**Fig. 6.** Wavelet multiple correlation for all time series returns

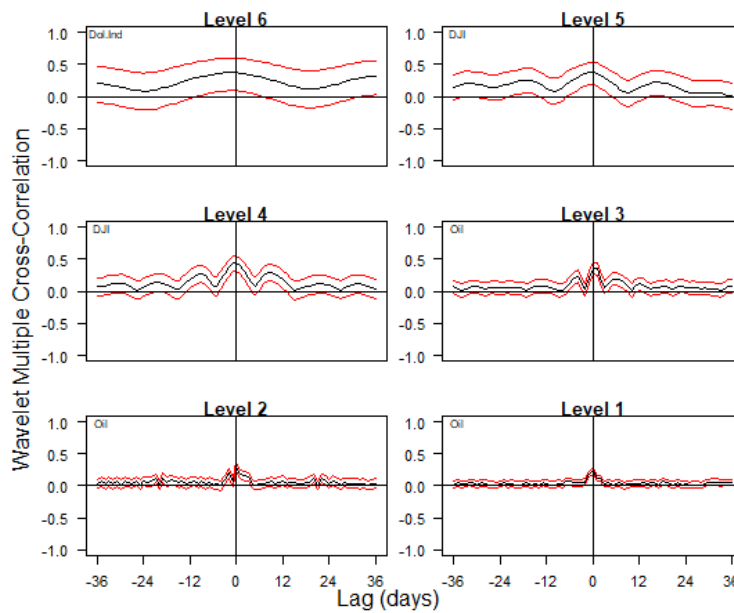
The multiple wavelet correlation of the oil market, the US dollar index and the Dow Jones index are small at low scales (2-4 days, 4-8 days, 8-16 days) and medium scales (16-32, 32-64 days) with a value of about 0.2 and at medium scales (64-128 days) with a value of about 0.3. In this case, the multiple correlation values increase at high scales (128-256 days, 256-512 days), starting from the value of 0.4 and reaching a maximum value of 0.8. The leading market is the oil one. Consequently, at high scales, the existence of a linear relationship between markets cannot be ruled out.

The wavelet multiple correlation of the gas market, the US dollar index and the Dow Jones index at low and medium scales is small, only on a high scale it reaches a maximum of 0.5. The leading is the US dollar index. The multiple correlations of the gas, oil and the Dow Jones index, as well as the multiple correlation of the gas, oil and the US dollar index, share common features. Namely, there is a small correlation at low and medium scales and a gradual increase of a correlation at high scales. In the first case, the oil market is steadily leading. In the second case, the US dollar index and oil price are leaders at scales (128-256 days) and (256-512 days) respectively.

The wavelet multiple cross-correlations for all time series returns at different levels of wavelet decomposition with lags up to one month are shown in Fig. 7. In the upper left corner of each graph a variable that maximizes the multiple correlation with the linear combination of the remaining variables is represented. Thus, it is identified a potential leader or follower for the entire system. The red lines correspond to the upper and lower limits of the 95% confidence interval. At levels 1-3, the oil market maximizes multiple correlations against a linear combination of other markets at all levels of the wavelet decomposition. At levels 4-5, the Dow Jones index has the potential to lead or lag the other markets, at level 6 the maximizing variable is the US dollar index. All variables are positively correlated on all scales, and they tend to co-movement. It is also noticeable that the correlation weakens with increasing lag. Accordingly, oil prices can be viewed as a leading barometer of global mood; changes

in this market affect the volatility of gas prices, the US dollar and the Dow Jones indexes.

At the next stage, a comparison of the predictive capabilities of various neural networks is made. The Long Short Term Memory (LSTM) and Wavelet Based Back Propagation (WBP) neural networks are considered. Brent oil prices and the US dollar index, as leaders of co-movement, daily from March 1, 2007 to January 22, 2019 are used. The LSTM neural network was modeled in the RStudio software environment with Keras and TensorFlow packages.

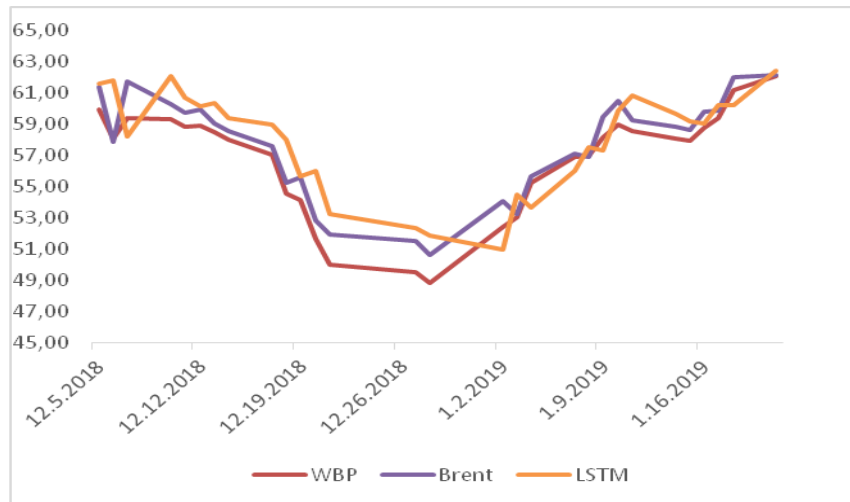


**Fig. 7.** Wavelet multiple cross-correlation for all time series returns

Before the beginning of the simulation process, it is necessary to prepare the input data. First of all, it is necessary to convert data to the stationary ones by finding the difference of the first order. The next step is to create an additional first-order lag variable, since LSTM involves learning a neural network with a teacher. All time series are divided into training and test parts. It was decided that 90% of the data was used to train the network, and, accordingly, 10% - for testing.

Pre-processing data also includes operations of normalization and data recovery. The network architecture consists of an input layer, one hidden layer, and an output layer. The hidden layer contains memory cells and corresponding device blocks that are characteristic of the recurrent neural network.

The WBP modeling was performed in the Alyuda NeuroIntelligence environment. The neural network architecture consisted of an input layer, one hidden layer, and an output layer. Fig. 8 shows the 30-day forecasting result for oil prices test data. Table 2 presents the RMSE and MAPE errors which were calculated for both series and for considered forecasting methods.



**Fig. 8.** Real data and forecasts of oil prices by WBP and LSTM methods

**Table 2.** Forecasting errors

	LSTM		WBP	
	RMSE	MAPE	RMSE	MAPE
Brent	1.70	0.0236	1.11	0.0162
DI	0.37	0.0032	0.27	0.0023

In general, empirical analysis shows that “deep learning” neural network gives possibility to build qualitative models with high forecasting accuracy. Due to the fact that with each iteration new nonlinear interconnections are constructed, we can achieve rather small values of errors. However, the comparison of forecasting errors suggests that the WBP method on short horizons gives better results.

## 5 Conclusion

The use of wavelet techniques for studying the dynamics of the time series of oil and gas prices, the Dow Jones index and the US dollar index allowed to establish some correlation relationships between volatility in the relevant markets. By means of discrete wavelet transform and continuous wavelet transform, the wavelet power spectrum of each series was constructed, wavelet coherence for time series pairs was investigated, and wavelet multiple correlation was determined.

In general, four global markets show a similar picture in terms of the wavelet power spectrum, which is confirmed by the high level of volatility at the medium scales. The levels of high volatility at the same intervals explain that there is a link between the changes in these markets, and the global economy is vulnerable to oil and gas prices, the value of the dollar index and the Dow Jones index.

High coherence of the series is observed both in crisis and in non-crisis periods. The largest correlation is marked at medium and high scales during 2008. With the interaction of oil and gas markets, the oil market is leading. The US dollar index influences (is leading) the formation of oil and gas prices. There are periods with a bidirectional relationship between the oil and gas markets, the Dow Jones index and the US dollar index at the medium and high scales.

Wavelet multiple correlations between the four markets are positive at all scales and become stronger with increasing horizons of time. The combination of financial markets (gas and oil market) and stock markets (the Dow Jones Index and the US dollar index) makes them increasingly integrated.

The wavelet multiple cross-correlations for all time series returns at different levels of wavelet decomposition with leads and lags up to one month were computed. According to the research results, oil prices can be considered as a leading barometer of world sentiment, changes in this market affect the volatility of gas prices, the US dollar and the Dow Jones indexes.

For series-leaders, forecasting models based on neural network of deep learning and Wavelet based Back Propagation were built. Comparison of the forecasting errors suggests that the application of both methods on short horizons gives good modeling results.

## References

1. Shah, A., Deo, M.: Integration of the Indian Stock Market: at the angle of Time-Frequency. *Journal of Economic Integration*, 31(1), 183-205 (2016). <http://dx.doi.org/10.11130/jei.2016.31.1.183>
2. Crowley, P.: An Intuitive Guide to Wavelets for Economists. Working Paper, Bank of Finland (2005).
3. Rua, A., Nunes, L.: International comovement of stock market returns: a wavelet analysis. *Journal of Empirical Finance*, 16, 632-639 (2009).
4. Alou, C., Hkiri, B.: Co-movements of GCC emerging stock markets: new evidence from wavelet coherence analysis. *Economic Modelling*, 36, 421-431 (2014).
5. Loh, L.: Co-movement of Asia-Pacific with European and US stock market returns: A cross-time-frequency analysis. *Research in International Business and Finance*, 29, 1-13 (2013).
6. Madaleno, M., Pinho, C.: International stock market indices comovements: a new look. *International Journal of Finance and Economics*, 17, 89-102 (2012).
7. Vacha, L., Barunik, J.: Co-movement of energy commodities revisited: Evidence from wavelet coherence analysis. *Energy Economics*, 34(1), 241-247 (2012).
8. Tiwari, A., Mutascu, M., Albulescu, C.: The influence of the international oil prices on the real effective exchange rate in Romania in a wavelet transform framework. *Energy Economics*, 40, 714-733 (2013).
9. Akoum, I., Graham, M., Kivihaho, J., Nikkinen, J., Omran, M.: Co-movement of oil and stock prices in the GCC region: a wavelet analysis. *Quarterly Review of Economics and Finance*, 52, 385-394 (2012).
10. Ramsey, J., Lampart, C.: Decomposition of economic relationships by timescale using wavelet. *Macroeconomic Dynamics*, 2, 49-71 (1998).

11. Gençay, R., Selçuk, F., Whitcher, B.: *An Introduction To Wavelets and Other Filtering Methods in Finance and Economics*. Academic Press, San Diego, CA (2002).
12. Percival, D., Walden, A.: *Wavelet Methods for Time Series Analysis*. Cambridge University Press (2000).
13. Gallegati, M., Semmler, W.: *Wavelet application in economics and finance*. NY: Springer (2014).
14. Fernández-Macho, J.: Wavelet multiple correlation and cross-correlation: A multiscale analysis of euro zone stock markets. *Physica A*, 391(4), 1097-1104 (2012).
15. Dajcman, S., Kavkler, A.: Wavelet analysis of stock return energy decomposition and return comovement- a case of some central European and developed European stock markets. *E a M: Ekonomie a Management*, 17(1), 104-120 (2014).
16. Dar, A., Bhanja, N., Samantaraya, A., Tiwari, A.: Export led growth or growth led export hypothesis in India: evidence based on time-frequency approach. *Asian Economic and Financial Review*, 3(7), 869-880 (2013).
17. Gallegati, M.: Wavelet analysis of stock returns and aggregate economic activity. *Computational Statistics & Data Analysis*, 52, 3061-3074 (2008).
18. Abid, F., Kaffel, B.: Time–frequency wavelet analysis of the interrelationship between the global macro assets and the fear indexes. *Physica A*, 490, 1028–1045 (2018).
19. Husain, A., Arezki, R., Breuer, P., Haksar, V.: *Global Implications of Lower Oil Prices*. International Monetary Fund (2015).
20. Gadanez, B., Jayaram, K.: Measures of financial stability – a review. *Bank of International Settlements. IFC Bulletin*, 31, 365-382 (2009).
21. Azar, A.: The relation of the US dollar with oil prices, gold prices, and the US stock market. *Research in World Economy*, 6(1), 159-171 (2015).
22. Malliaris, G., Malliaris, M.: Are oil, gold and the euro inter-related? time series and neural network analysis. *Review of Quantitative Finance and Accounting*, 40(1), 1-14 (2013).
23. Yoshino, N., Taghizade-Hesary, F.: Monetary policy and oil price fluctuations following the subprime crisis. *International Journal Monetary Economics and Finance*, 7(3), 157-174 (2014).
24. Aguiar-Conraria, L., Soares, J.: The continuous wavelet transform: Moving beyond uni and bivariate analysis. *J. Econ. Surv.*, 28(2), 344-375 (2014).
25. Chen, L., Qiao, Z., Wang, M., Wang, C., Du, R., Stanley, H.: Which artificial intelligence algorithm better predicts the Chinese stock market? *IEEEAccess*, 6, 48625-48633 (2018).
26. Daubechies, I.: *Ten Lectures on Wavelets*. SIAM: Society for Industrial and Applied Mathematics (1992).
27. Torrence, C., Compo, G.: A practical guide to wavelet analysis. *Bulletin of the American Meteorological Society*, 79(1), 61-78 (1998).
28. Fernández-Macho, J.: Time-Localized Wavelet Multiple Regression and Correlation. *Physica A*, 490, 1126-1236 (2017). DOI: 10.1016/j.physa.2017.11.050.
29. Jerome, T., Douglas, R., Atlas, L.: Recurrent neural networks and robust time series prediction. *IEEE transactions on neural networks*, 5(2), 240-254 (1994).
30. LeCun, Y., Bengio, Y., Hinton, G.: Deep learning. *Nature*, 521, 436-444 (2015).
31. Chong, E., Han, C., Park, F.: Deep learning networks for stock market analysis and prediction: Methodology, data representations, and case studies. *Expert Syst. Appl.*, 83, 187-205 (2017).
32. Jin, W., Li, Z., Wei, L., Zhen, H.: The improvements of BP neural network learning algorithm. In *Proc. WCCC ICSP*, 1647-1649 (2000).
33. Eynard, J., Grieu, S., Polit, M.: Wavelet-based multi-resolution analysis and artificial neural networks for forecasting temperature and thermal power consumption. *Engineering Applications of Artificial Intelligence*, Elsevier, 24(3), 501-516 (2011).



# Short-term Electricity Price Forecasting Using Generalized Additive Models

Jan-Hendrik Meier<sup>1</sup>[0000-0002-3080-2210], Stephan Schneider<sup>1</sup>[0000-0003-1810-8813],  
Chan Le<sup>1</sup>

<sup>1</sup> Kiel University of Applied Sciences, Sokratesplatz 2, 24149 Kiel, Germany  
jan-hendrik.meier|stephan.schneider@fh-kiel.de

**Abstract.** If one examines the spot price series of electrical power over the course of time, it is striking that the electricity price across the day takes a course that is determined by power consumption following a day and night rhythm. The daily course changes in its height and temporal extent in both, the course of the week, as well as with the course of the year. This study deals methodologically with this intra-day and seasonal behaviour. We contribute the usage of Generalized Additive Models (GAM) and apply these models with European data.

**Keywords:** electricity prices, forecasting, generalized additive models.

## 1 Introduction

Since the come about of energy deregulation in the 1990s, the electric power industry has undergone significant restructuring, driving the market away from its natural monopoly and opening chances for thriving competition and reduction in prices through privatization. As a result, the last two decades have seen a remarkable rise in importance of electricity price forecasting (EPF). Invaluable inputs are provided in aid of optimal decisions and responses from both producers and retailers in the pool-based market.

Electricity, though conforming to the definition of a commodity [11], is a special case with very distinct characteristics: non-storability of electricity, inelasticity of the short-term demand, wide spectrum of cost, and oligopolistic behavior of the generators [20]. Without any loss-free form of storage, it is crucial that great effort is needed to ensure and maintain the stability of a balanced supply and demand [10]. Hence, there are many challenges in modeling electricity prices.

In comparison to the time series of the electricity load, Aggarwal et al. [1] mentioned that the series of the electricity price oftentimes contains patterns of much greater complexity, including non-constant mean and variance, strong seasonality and various calendar effects. Moreover, EPF models must effectively cope with numerous abrupt large jumps in the course of the time series. This phenomenon is attributable to problems with transmission infrastructure and unforeseeable, non-proportional or inverse fluctuations in demand and supply [8]. Ziel et al. [28] also pointed out that the

existence of a universal model for electricity price forecasting is highly improbable due to vast differences among countries, such as their individual political and climatic circumstances. Thus, not all the findings and methodologies successfully employed to one country are applicable to another country or region.

For these reasons, many different approaches to electricity price forecasting have been proposed to various extents of effectiveness and success. Papers published by Weron [24, 26] summarize the current methods of EPF, reviewing their strengths and weaknesses, effectiveness and potential, as well as providing an outlook on this topic over the next decade. For more than 15 years, various solutions and fitting models can be categorized into the following groups of methodology: fundamental/structural methods, reduced-form quantitative, stochastic models, statistical approaches, and computational intelligence; many of which being hybrid of two or more of these groups. These papers also emphasize the importance of appropriate inputs and predictors, along with the possibility of capturing different levels of seasonality in the models. Moreover, the author suggests extensions of the methodology going far beyond point forecasting: interval forecasting, density forecasting, threshold forecasting, and their combinations.

This paper proposes the use of the Generalized Additive Models (GAM) in attempt to improve the quality of the electricity spot price forecasting by applying a non-parametric estimation of multiple seasonal predictors. In the case of multivariate analysis, the key problem is to fit a  $d$ -dimensional model to the observed data, which leads to the exponential increase in the model's complexity as more variables or features are added to the dataset [18]. To combat this so-called "curse of dimensionality", a term coined by Bellman [3], the Additive Model method deals with each dimension separately, treating them as individual univariate smooth functions and adding up their approximations. This allows for an interpretable solution in which the marginal impact of a single variable could be explained independently of the other variables. Following this, the GAM method takes a major step forward where the response variable may be derived from any exponential family distribution, thus removing even further constraints and allowing greater flexibility, capturing nonlinear patterns that a classic linear model would otherwise miss [27]. Moreover, with the utilization of tensor product smooth interactions, the degree of smoothness in each direction can be controlled independently, resulting in an overall anisotropic penalty.

A comparable GAM was introduced by Pierrot and Goude [17] based on the hourly electricity load data in France from 2000 to 2005. Twenty-four separated time series regarding the daily observations are considered and fitted by the correspondent models. These models are set up to account for various levels of seasonality: daily, weekly, monthly, and a yearly global trend, so that a summer break (a large downturn in electricity demand during summer holidays) could be incorporated. Additionally, hourly meteorological data is included, e.g. the temperature, the cloud cover and the wind speed. A semi-parametric approach is adopted to these models, comprising a regressive part with explanatory variables and an autoregressive part with lagged loads. In the end, the residuals of the models are examined to detect remaining autocorrelation. The best model selection was conducted based on the comparison of the Generalized Cross Validation (GCV) scores. The forecasting results from this model,

measured using the Root Mean Square Errors (RMSE), were significantly better than the unspecified benchmark model used by the authors.

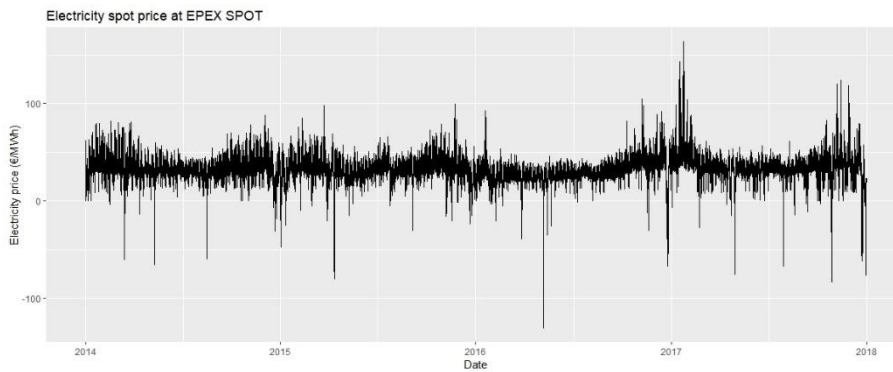
In addition to point forecasting, Serinaldi [20] introduced the GAM for Location, Scale and Parameter (GAMLSS) for short-term price forecasting, based on the work of Stasinopoulos and Rigby [22, 23]. The aim of this paper is to reduce uncertainty of EPF by explicitly incorporating a wide range of distribution functions into the model, where the parameters of these distribution functions change dynamically in the course of a day, week, and year. According to this paper, the use of a position parameter, reflecting daily and weekly periodicity, a scale parameter, encompassing daily price standard deviation, and a shape parameter in form of a constant value is emphasized. The GAMLSS performance was put to test against many statistical benchmarks, from the naïve method [15], the classical linear Autoregressive model (AR) and Generalized Autoregressive Conditional Heteroskedastic model (GARCH) [13], to the Threshold Autoregressive (TAR) models [15]. In some instances, the performance of GAMLSS outstood the reference models and proved to be a reliable method for the comparison among different forecasting procedures.

Fan and Hyndman [7] took a semi-parametric additive approach with the aim of developing short-term forecasting models for regions in the National Electricity Market (NEM) of Australia from 1997 to 2009. In order to predict half-hourly demand loads, 48 sets of model parameters were estimated for each half-hour slice. For the point forecasting, the proposed additive regression model framework allowed non-linear and non-parametric terms to be accounted for the fit of the electricity load. Within the model setup, three main effects were determined. Calendar effects include annual, weekly and daily seasonality, with public holidays also being recorded. Temperature effects from two sites are considered, whose average temperature and the differences between the daily maximums and minimums were incorporated into the model. Lagged demand effects were added to capture the autocorrelations within the demand time series, as well as its variance throughout the time. Prior to execution, a piece-wise backwards variable selection process was implemented to identify the best model, using the Mean Average Percentage Error (MAPE) as the selection criterion. In addition to the point forecasting, the forecasting outcome distribution was also estimated, providing a further indication of the forecast accuracy. Since the parametric method of delivering the forecasting distribution and prediction intervals would assume an i.i.d. error with zero mean and finite variance, the alternative of using bootstrapping as a non-parametric approach is encouraged, which is robust against violations of the normality assumption. Due to heavy computational tasks, a modified bootstrap method was conducted, constructing the empirical prediction intervals by centering the simulated forecast residuals around the original predicted point values.

The remainder of the paper is organized as follows. Section 2 provides a brief exploratory analysis to the data used in this study. Section 3 introduces GAM, as well as the model setup. Section 4 shortly introduces the structure and setup of the benchmark models. Section 5 evaluates the forecasting results. Finally, conclusion closes the study.

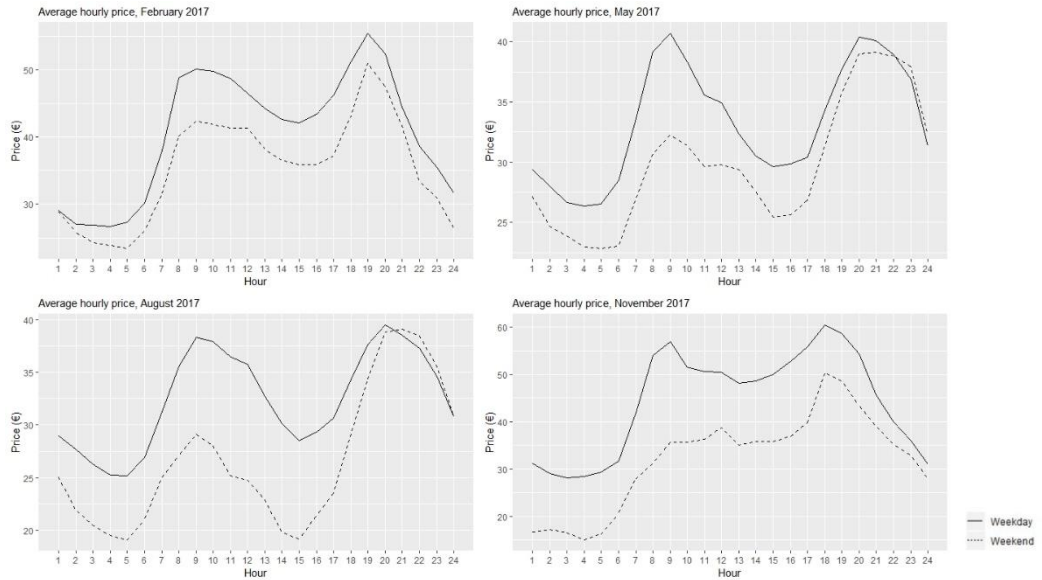
## 2 Sample and Methodology

This study focuses on the course of the hourly day-ahead spot price of the EEX Phelix-DE contract at the EPEX SPOT market of the European Power Exchange (EEX). This day-ahead spot contract is considered as a benchmark contract for European electricity. The exchange operates, among other trading activities, the power spot market for Germany, Austria, Luxembourg, France, the United Kingdom, the Netherlands, Belgium, and Switzerland. Purchase and sale orders are placed hourly for power which will be delivered the following day. The daily cycle ends at 12:00 pm, at which time the EPEX SPOT calculates the market clearing price. The visualization of the data used in this study can be seen in Figure 1.



**Fig. 1.** Electricity spot price at EPEX SPOT

Figure 2 shows the average daily electricity price trend for four exemplary months in 2017, separately for weekdays and weekends. An overall M-shaped daily pattern throughout all months is evidently recognizable. The price is comparatively low for the first five hours of the day before rising to its first peak around 9 am, followed by a local minimum around 3 pm, peaking again around 8 pm before decreasing back to night level. Furthermore, the graphs also show a weekly pattern, as the weekend spot prices are constantly below those of the weekdays. Monthly seasonality also plays a part in determining the spot prices. Spring and summer time see a steeper mid-day gradient, while during fall and winter the price declines more constantly without retaining its peak.



**Fig. 2.** Average hourly price for selected months in 2017, weekdays vs. weekend

### 3 The Generalized Additive Model

#### 3.1 The GAM theory

Generalized Additive Model (GAM) [9, 27] is a non-parametric extension of the Generalized Linear Model (GLM), in which the relationship between the response and predictors are expressed by several smooth functions in order to capture the non-linearities underlying the data. The GAM can be formally expressed as:

$$g(E(y_i)) = \beta_0 + f_1(x_{i1}) + \dots + f_p(x_{ip}) + \varepsilon_i \quad (1)$$

where  $i = 1, \dots, N$ ,  $g$  is a link function (identical, logarithmic or inverse, etc.),  $y$  is a response variable,  $x_1, \dots, x_p$  are independent variables,  $\beta_0$  is an intercept,  $f_1(x_{i1}), \dots, f_p(x_{ip})$  are unknown non-parametric smooth functions, and  $\varepsilon$  is an i.i.d. random error.

One way of determining these smooth functions is through the use of smoothing splines [9, 27]. These piecewise polynomial functions join many polynomials to generate a smooth curve through a set of points. The polynomials connect at certain points, called knots. At these knots, the joint polynomials share the same derivatives up to several degrees. The level of model smoothness depends on the degree of the polynomials, the number of knots, and their location. The locations of these knots are typically evenly-spaced. In this case, the smooth function is estimated by minimizing the penalized sum of squares:

$$\min(RSS) \rightarrow \left( \sum_{i=1}^n [y_i - f(x_i)]^2 + \lambda \int_{x_{min}}^{x_{max}} [f''(x)]^2 dx \right)^* \quad (2)$$

The first half of the function,  $\sum_{i=1}^n [y_i - f(x_i)]^2$ , is the standard residual sum of squares, representing how closely the fitted values are in alignment with the observed values, whereas the second half,  $\int_{x_{min}}^{x_{max}} [f''(x)]^2 dx$ , penalizes the “roughness”, or the “wiggleness” of the data. Minimizing the integrated square of the second derivative would smooth out the data towards linearity. The key here is the smoothness parameter  $\lambda$ , which controls the trade-off between model fit and model smoothness. Wood [25] postulates, that the natural cubic splines are the smoothest interpolators, making the cubic smoothing splines (a natural cubic spline with knots at every data point) the best choice regarding the polynomial degree of the smooth term. However, this procedure has one major disadvantage: if the number of knots is approximately equal to the number of data records  $n$ , this will lead to model overfitting, and furthermore to a computational waste. Since  $\lambda$ , in most cases, obviously shrinks down the roughness at many knots, this will result in a spline that is much smoother than  $n$  degrees of freedom.

Another alternative to the presentation of the smooth functions is the penalized regression spline [27]. It can be expressed as a linear combination of a family of basis functions:

$$s(x_j) = B_0(x_j)\beta_0 + B_1(x_j)\beta_1 + \dots + B_q(x_j)\beta_q = \mathbf{B}'\boldsymbol{\beta}, \forall j = 1 \dots p \quad (3)$$

where  $B_0(\cdot), \dots, B_q(\cdot)$  are the basis functions,  $\beta_0, \dots, \beta_q$  are the associated coefficients with the basis dimension  $q$ , so that a linear relationship between the predictor and the smooth function is formed through the basis functions, with  $\mathbf{B}$  being the model matrix of the basis functions, and  $\boldsymbol{\beta}$  being the vector of regression coefficients. These coefficients applied to the basis functions act as amplifiers of the curvature of the spline. Like in the case of the above-mentioned smoothing spline, it is also possible to apply a penalty in the course of estimating the basis function coefficients of the regression spline to produce smoothness. Hence, in lieu of solving for the estimated  $\hat{\boldsymbol{\beta}}$  with a standard linear model, the penalized sum of squares can be minimized:

$$\min_{\boldsymbol{\beta}}(RSS) \rightarrow (\|\mathbf{y} - \mathbf{B}'\boldsymbol{\beta}\| + \boldsymbol{\beta}'\mathbf{P}\boldsymbol{\beta})^* \quad (4)$$

where  $\mathbf{P}$  is the penalty matrix, imposing smoothness by directly penalizing the difference among the adjacent coefficients. This method is called the Penalized Iteratively Reweighted Least Squares method (P-IRLS), that for any given  $\lambda$ , the regression coefficients  $\hat{\boldsymbol{\beta}}$  can be obtained.

Hence, the problem has shifted from measuring the degree of smoothness for the model to determining the smoothing parameter  $\lambda$ . Since there is a trade-off between overfitting and oversmoothing the data, one option of determining the optimal degree of smoothness is by implementing backwards selection. This method is rather computationally expensive and can also result in relatively poor model accuracy due to uneven knot spacing. Instead, the smoothing parameter  $\lambda$  can be estimated using either the Generalized Cross Validation criteria (GCV) or the mixed model approach via Restricted Maximum Likelihood (REML).

With regard to the available choices of regression splines, GAM offers a wide range of smoothing bases, including cubic regression splines, cyclic regression splines, thin plate regression splines, P-splines, etc. These models differ in the choice of number of knots, the spacing of the knots, the level of rank and order, as well as the number of predictors in the model. Moreover, the interactions among the predictors play a critical role in the regression model. The inclusion of interactions extends from the most basic form of multiplication to the tensor product, allowing the possibility of implementing different smoothing bases for variables while applying penalization in different ways, resulting in an anisotropic penalty. In this paper, the use of tensor product smooth and the choice of cyclic penalized cubic thin plates regression spline are emphasized through the model setup below.

### 3.2 Model setup

Aggarwal et al. [1] classified the factors that have possible impact on the electricity prices in five different categories: market characteristics, nonstrategic uncertainties, other stochastic uncertainties, behavioral aspects, and temporal effects. As shown in the data analysis, there are three main seasonal patterns: the daily effect, weekly effect, and yearly effects which are represented by the dichotomous explanatory variables hour of the day, day of the week, and month of the year.

The goal of this model is to produce short-term forecasts for 12 randomly chosen weeks (one in each month) within the year 2017. For this setup, each model receives 260 weeks (approximately five years) of training data prior to the forecasted week. We begin setting up the model structure by determining the smooth function components for the daily, weekly and yearly pattern separately. Thus, in model M1 the individual effects form three different univariate smooths additively:

$$\mathbf{M1}: P_t = f_1(\text{Daily}) + f_2(\text{Weekly}) + f_3(\text{Yearly}) + C + \varepsilon_i \quad (5)$$

Cubic regression splines were applied for all individual components. The number of knots is equal to the number of unique values in each predictor, in this case 24, 7, and 12, respectively. This initial model treats the three predictors individually, assuming that all effects are independent. This assumption is not realistic, since in the exploratory data analysis it could be observed that the effects are mutually dependent.

To account for the interaction among the predictors, thin plate regression splines are recommended by the extant literature [27]. Here, a truncated version of the thin plate splines is applied, using the thin plate spline penalty to acquire a low-rank smoother that has far fewer coefficients than there is data to smooth. Moreover, it can deal with any number of predictors and tends to give the best MSE performance [27]. Accordingly, the same isotropic smoothing base is used for all three predictors in one smooth function:

$$\mathbf{M2}: P_t = f(\text{Daily}, \text{Weekly}, \text{Yearly}) + C + \varepsilon_i \quad (6)$$

In this case, only one single value of the smoothing parameter  $\lambda$  is applied in all directions. The problem with this isotropic penalty is, that its result is only reliable when the predictors are approximately on the same scale. In other words, the discrep-

ancy among the different units of the different explanatory variables could result in a false integration of the second derivative due to their disproportional contribution to the overall integration. Hence, the use of tensor product smooths is proposed [27].

Tensor product smoothing is a type of multivariate smoothing base that derives the multivariate bases from individual univariate marginal bases. In other words, the non-separable smooth function  $f(\text{Daily}, \text{Weekly}, \text{Yearly})$  can instead be approximated by the tensor product of its component,  $f(\text{Daily})$ ,  $f(\text{Weekly})$  and  $f(\text{Yearly})$ . Each of the basic functions is smoothed in its corresponding dimensions individually, so that the correspondent coefficient matrix is obtained. Then the tensor product ( $\otimes$ ) of the three matrices is computed, as shown in model M3:

$$\mathbf{M3}: P_t = f_1(\text{Daily}) \otimes f_2(\text{Weekly}) \otimes f_3(\text{Monthly}) + C + \varepsilon_i \quad (7)$$

As a result, each component represents a unique combination of the three marginal basis functions. This allows for an overall anisotropic smoothing penalty, with the possibility of using different smoothing bases for every predictor and penalize it in many different ways. Each smoothing parameter  $\lambda_{\text{Daily}}$ ,  $\lambda_{\text{Weekly}}$  and  $\lambda_{\text{Yearly}}$  is individually determined through the same method as the single smoothing parameter for the univariate smoothing, which results in an overall tensor product smooth that is indifferent to the rescaling of its independent variables.

Although this method proves to yield significantly better results, it also becomes significantly more computationally expensive as the dimensionality of the tensor product increases by the introduction of more predictors. Within the framework of this paper, this issue is addressed by using the pairwise bivariate tensor product smooths for the three predictors, resulting in model M4:

$$\mathbf{M4}: P_t = f_1(\text{Daily}) \otimes f_2(\text{Weekly}) + f_1(\text{Daily}) \otimes f_3(\text{Yearly}) + f_1(\text{Weekly}) \otimes f_3(\text{Yearly}) + C + \varepsilon_i \quad (8)$$

Finally, the combination of the three individual effects and their three mutual interactions enables the decomposition of the model, analyzing to what extent each individual predictor influences the response individually, as well as each of the pairwise interactions. Accordingly, the ultimate model M5 can be annotated as follows:

$$\mathbf{M5}: P_t = f_1(\text{Daily}) + f_2(\text{Weekly}) + f_3(\text{Yearly}) + f_1(\text{Daily}) \otimes f_2(\text{Weekly}) + f_1(\text{Daily}) \otimes f_3(\text{Yearly}) + f_1(\text{Weekly}) \otimes f_3(\text{Yearly}) + C + \varepsilon_i \quad (9)$$

In the extant literature a variety of model accuracy measures are discussed. The trade-off between model accuracy and model complexity is often in the focus of the consideration. Accuracy measures that penalize for model complexity are proposed by Akaike (Akaike Information Criterion, AIC) [2] and Schwarz (Bayes Information Criterion, BIC) [19]. However, the AIC and the BIC are typical in-sample accuracy measures. Since this study deals with forecasting accuracy and not with model fitting, an out-of-sample / forecasting accuracy measure needs to be applied. A popular choice among the forecasting accuracy measures, the Mean Absolute Percentage Error (MAPE) fails in the context of price forecasting, since the spot prices for electricity are oftentimes negative, which leads to a possible erroneous interpretation. Moreover, when the prices are high, MAPE is rather indifferent to a considerable absolute change, whereas it would scale up drastically to the same price difference, when the



prices are close to zero. In line with extant literature, the weekly Root Mean Square Errors (RMSE) is used for the evaluation of the forecasting accuracy here [26].

## 4 Statistical benchmark models

### 4.1 Autoregressive Integrated Moving Average model with external regressors (ARIMAX) with seasonality

The benchmark ARIMAX model in this paper, as derived by Meier et al. [14], is an extension of the classical ARIMA model [4]. The X-term of the model comprises the external regressors, accounting for various level of seasonality in form of dummy-coded variables, including hour of the day, day of the week, and month of the year. The Hyndman-Khandakar algorithm [12, 13] is utilized to achieve the optimal ARIMAX parameterization. This step includes the determination of the number differentiations (d) needed to achieve stationary using the KPSS tests as well as the simultaneous determination of the number of lags for the autoregressive (p) and the moving average (q) term, applying Akaike Information Criterion (AIC). Since the data sample is identical with Meier et al. [14] in both analyses, the original ARIMAX (3,1,3) model with 40 dummy variables is adopted as the benchmark model for this paper.

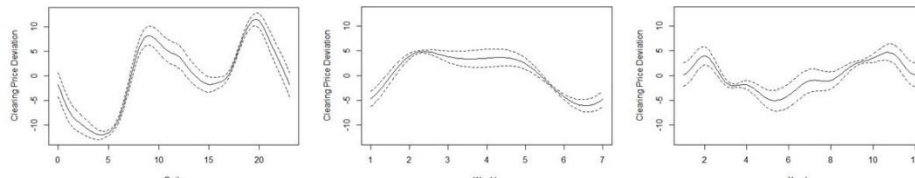
### 4.2 Naïve forecasts

The similar-day method estimates the electricity price of a certain day on the basis of the electricity price of the same weekday of the previous week [21, 24]. Further adaptations of this method match characteristics like the hour of the day, the day of the week, the month of the year by applying linear combinations or regression procedures. One of the variations of the similar-day method, is the naïve method. Here the forecast is based on the previous day, with the exception of the Saturdays, Sundays, and Mondays. These are forecasted by looking back to values of the previous week [16, 24]. Despite its simplicity, this “naïve test” proves its effectiveness in identifying inept forecasting models, thus turning it into one of the most popular benchmark models in EPF [5, 6, 16].

## 5 Assessment of the model performance

Figure 3 represents three seasonal smoothed effects of the electricity price time series which originate from model M5: daily, weekly and yearly. As seen in the data analysis, these plots confirm that there is a difference in price throughout the course of a day, throughout the course of a week, and throughout the course of a year. The first daily peak around 10:00 am could be due to the morning working routines, and the second one around 8:00 pm accounts for the heating and lighting needs in winter, as well as extra activities in summer, where there is a longer period of daylight. The electricity price is fairly stable at a higher level from Tuesday to Friday, and sinks at

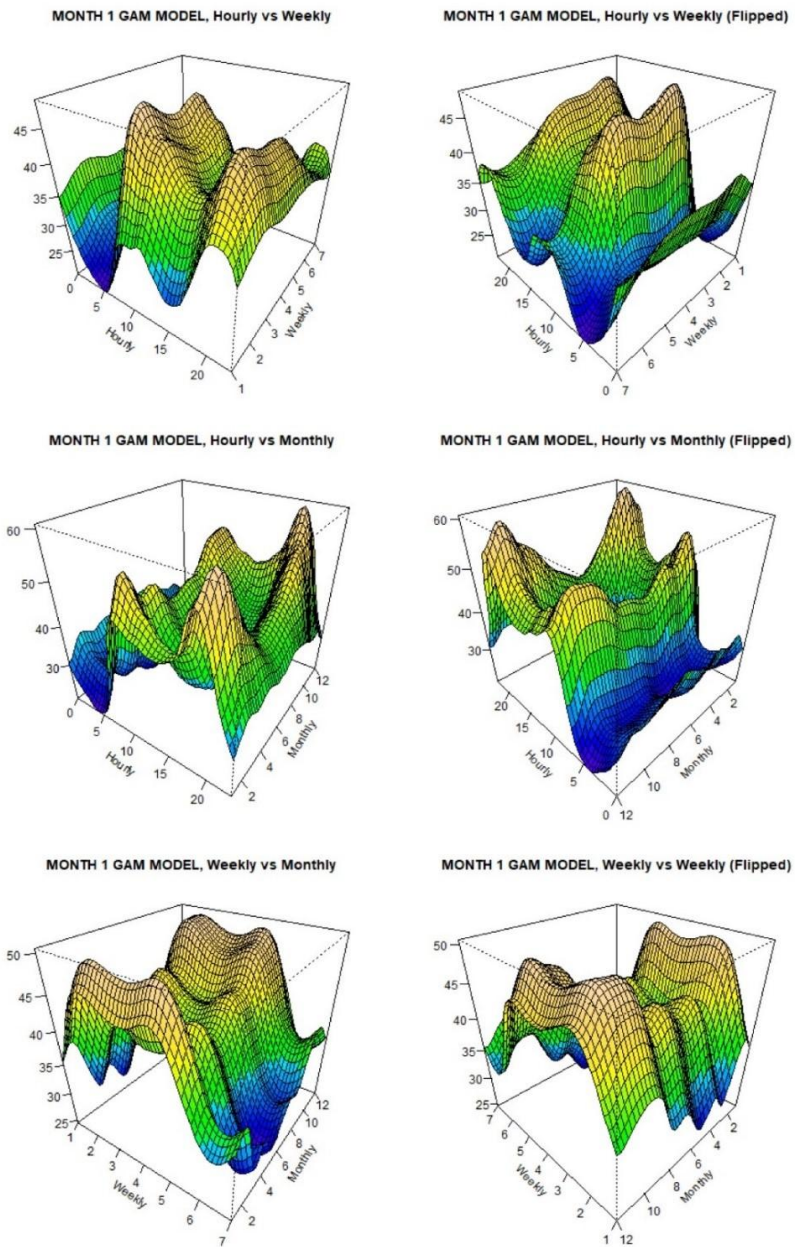
the weekend to rise again at the Monday, confirming the higher need for electricity on working days. Regarding the yearly pattern, the prices in fall and winter are higher than in the other two seasons, emphasizing the heating and lighting demands.



**Fig. 3.** The electricity price as a mean deviation with forecasting intervals

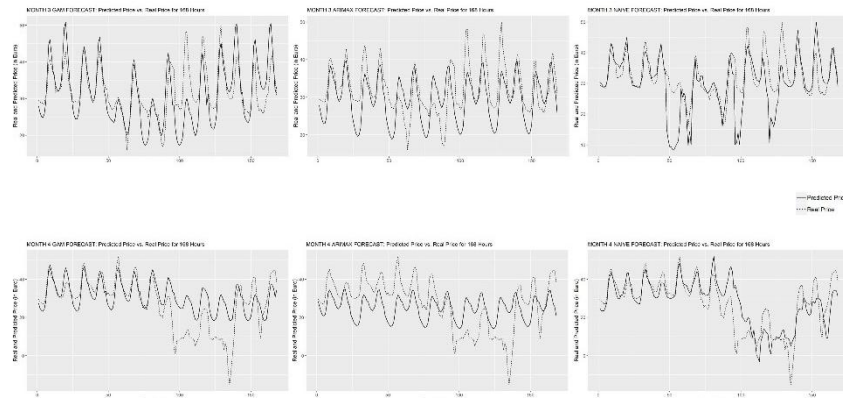
Figure 4 shows the tensor product smooths of the effects in pairs, so that the interaction among the effects are easier to spot. It can be observed from the daily and weekly smoothing, that the daily peaks around 10 am and 8 pm are still prominent throughout the week, although at a remarkably lower level at the weekends. The middle graphs show the relationship between the weekly and the yearly effect: the daily peaks are now smoothed along different months, with the prices in summer lower than in winter, showing peaks at the morning and evening time in December and January. Lastly, the tensor product between the weekly and yearly effect showcases a minimum price on Sundays in May, as opposed to the maximum on Mondays in January.

These figures demonstrate one of the most decisive advantages of GAM in comparison to other methods: interpretability with visualization. GAM takes on the nature of an additive regression model, in which the interpretation of the marginal impact of a singular variable, the partial derivative, is not contingent on the values of the other variables in the model. Looking at Figure 3, one could intuitively draw conclusion on the effects the temporal predictors have on the electricity prices, each of which is accounted for separately by an individual smoothed function; so that the daily peaks, the weekend cutback, and the decrease of prices in summer months are appointed to the right temporal effects accordingly. Moreover, GAM is able to isolate the individual effects from the predictors alone from the intercorrelated influences among them upon the response variable; for instance, in our final model, the influence of the hourly variable alone, the interaction between the hourly and the weekly variable, as well as the one between the hourly and the monthly variable, are all accounted for separately. Figure 4 shows the interactions being plotted, so that the original patterns could be revealed, even though the dataset at hand may suggest a noisier relationship. Hence, by simply taking a glance at the output and its visualization of the model, one can make intuitive statements about the effects of the predictors which is comprehensible to a nontechnical person.



**Fig. 3.** Pairwise tensor product interactions (with flipped graphs), model 1

Figure 5 illustrates the forecasting accuracies of the GAM, ARIMAX and naïve models applied using the months of March and April of the 2017 forecast period as examples.



**Fig. 4.** Forecast vs. real time series

Table 1 documents the forecasting accuracy of the GAM against the other two benchmark models. The GAM proves to be more accurate in the overall testing and less prone to price peaks and troughs. In roughly 75% of the cases GAM shows better forecasting accuracies than the benchmark models.

**Table 1.** Forecasting performance of GAM in comparison with the benchmark models

Training Phase		Test Phase		Comparison (RMSE of Real vs Predicted Price)		
Begin	End	Begin	End	GAM	ARIMAX	Naïve
10.01.2012	02.01.2017	03.01.2017	09.01.2017	16.78	17.331	16.816
10.02.2012	02.02.2017	03.02.2017	09.02.2017	19.185	12.713	12.668
28.03.2012	21.03.2017	22.03.2017	28.03.2017	5.796	5.95	7.386
23.04.2012	16.04.2017	17.04.2017	23.04.2017	10.487	12.494	8.565
08.05.2012	01.05.2017	02.05.2017	08.05.2017	6.639	18.588	27.218
02.07.2012	25.06.2017	26.06.2017	02.07.2017	5.638	6.765	6.87
13.07.2012	06.07.2017	07.07.2017	13.07.2017	6.2	4.93	6.218
27.08.2012	20.08.2017	21.08.2017	27.08.2017	6.427	11.116	10.042
23.09.2012	16.09.2017	17.09.2017	23.09.2017	5.817	8.65	10.121
08.10.2012	01.10.2017	02.10.2017	08.10.2017	18.791	13.901	20.018
06.12.2012	29.11.2017	30.11.2017	06.12.2017	12.073	13.384	8.776
15.12.2012	08.12.2017	09.12.2017	15.12.2017	12.454	12.884	13.799

For checking the robustness of the presented GAM models, the outliers were identified and substituted by applying the seasonal and trend decomposition method Loess (Locally Weighted Least Squares Regression). Loess smoothing calculates an average of the data around the vicinity, giving more weight to data near the vicinity and less weight to data further away from the vicinity. Given the identical model set up, the

GAM model fitting process shows little difference in results when fed with the original or the modified input data. Accordingly, the GAM model is robust towards outliers. Nevertheless, the identified outliers are not measurement inaccuracies but real clearing prices and reflect the stark fluctuation of the electricity price time series. Thus, they should be included in the model.

Furthermore, it was examined whether the length of the training data time series has an influence on the forecasting accuracy. Hypothetically, the quality of the model would monotonically rise as the number of training data records increases. We were not able to find an optimum length of the training time series that could be applied for all months. This indicates that a large number of structural breaks make a perfect adaptation of the model impossible. These structural breaks are mainly due to the strong promotion of renewable energies in Germany, which over time are accompanied by a strong increase in volatility and are predominantly politically driven.

## 6 Conclusion

In this study, the use of Generalized Additive Model (GAM) [9, 27] is proposed as an alternative stochastic method to conduct one-week ahead forecasting of electricity market prices. Overall, GAM is an extension of the Generalized Linear Model, demonstrating its superiority in terms of flexibility, in which the relationships between the predictor and the response variables are assumed to be non-linear. A model using isolated additive smoothing components according to our model M1 could therefore not exploit the advantages of GAM, since the interactions between the dimensions are not taken into account. The complete consideration of all interactions of the predictors in only one smoothing function lead to the best prediction accuracies, but is so computationally intensive that, so that its practical applicability is rather limited. A significant improvement was the use of tensor smoothing function in our model M3, where the single smoothing functions were connected via the tensor product. In order to be able to work out the interactions between the dimensions even better without running the risk of achieving high computing capacities again, we developed the models M4 and M5. These models combine the tensor products between the smoothing functions pairwise, so that an excessive computing load is avoided and the interaction effects can still be reproduced with sufficient accuracy.

## References

1. Aggarwal, S. K., Saini, L. M., Kumar, A. Electricity price forecasting in deregulated markets: a review and evaluation. *International Journal of Electrical Power & Energy Systems*, 31(1), 13-22 (2019).
2. Akaike, H. Information theory and an extension of the maximum likelihood principle. *Second International Symposium on Information Theory*, 267–281 (1973).
3. Bellman R.E. *Adaptive Control Processes*. Princeton University Press, Princeton, NJ (1961).

4. Box, G. E. P., Jenkins, G. M. Time series analysis: forecasting and control. Holden-Day, San Francisco (1971).
5. Conejo, A., J., Contreras, J., Espinola, R., Plazas, M. A. Forecasting electricity prices for a day-ahead pool-based electric energy market. *International Journal of Forecasting*, 21(3), 435-462 (2005).
6. Contreras, J., Espinola, R., Nogales, F. J., Conejo, A. J. ARIMA models to predict next-day electricity prices. *IEEE Transactions on Power Systems*, 18(3), 2003, 1014-1020.
7. Fan, S., Hyndman, R. J. Short-Term Load Forecasting Based on a Semi-Parametric Additive Model. *IEEE Transactions on Power Systems*, 27(1), 134-141 (2012).
8. Geman, H., Roncoroni, A. Understanding the fine structure of electricity prices. *Journal of Business*, 79(3), 1225-1261 (2006).
9. Hastie, T., Tibshirani, R. Generalized Additive Models. Chapman & Hall, London (1990).
10. Hong, T. Energy Forecasting: Past, Present, and Future. *Foresight: The International Journal of Applied Forecasting*, 32, 43-48 (2014).
11. Hope, E., Rud, L., Singh, B. Electricity futures market. In Lesourd, J.-B., Percebois, J., Valette, F. (eds.), *Models for Energy Policy*. Routledge, London, New York, 238-249 (1996).
12. Hyndman, R. J.: R Package “forecast”: Forecasting Functions for Time Series and Linear Models, 2018.
13. Hyndman, R. J., Khandakar, Y. Automatic Time Series Forecasting: The forecast package for R. *Journal of Statistical Software*, 27(3), 2008.
14. Meier, J.-H., Schneider, S., Schönfeldt, T., Schüller, P., Wanke, B. Electricity Price Forecasting: A methodological ANN-based Approach with special Consideration of Time Series Properties. *ICTERI Conference Kiev. Proceedings of the 14th International Conference on ICT in Education, Research and Industrial Applications. Integration, Harmonization and Knowledge Transfer. Volume II: Workshops. Part I: 6th International Workshop on Information Technologies in Economic Research (ITER)*, Paper 5, 2018.
15. Misiorek, A., Trueck, S., Weron, R. Point and interval forecasting of spot electricity prices: linear vs. non-linear time series models. *Studies in Nonlinear Dynamics & Econometrics*, 10(2), 2006.
16. Nogales, F. J., Contreras, X., Conejo, A. J., Espinola, R. Forecasting next-day electricity prices by time series models. *IEEE Transactions on Power Systems* 17, 342-348 (2002).
17. Pierre, G., Goude, Y., Nedellec, R. Semi-Parametric Models and Robust Aggregation for GEFCom2014 Probabilistic Electric Load and Electricity Price Forecasting. *International Journal of Forecasting*, 32(3), 1038-1050 (2015).
18. Schimek, M. G., Turlach, B. A. Additive and generalized additive models: A survey. *SFB 373 Discussion Papers*, 1998.
19. Schwarz, G. Estimating the dimension of a model. *Annals of Statistics* 6, 46-464 (1978).
20. Serinaldi, F. Distributional Modeling and Short-Term Forecasting of Electricity Prices by Generalized Additive Models for Location, Scale and Shape. *Energy Economics*, 33(6), 1216-1226 (2011).
21. Shahidehpour, M., Yamin, H., Li, Z. Market operations in electric power systems: forecasting, scheduling, and risk management. Wiley, New Jersey (2002).
22. Stasinopoulos, M. D., Rigby, R. A. Generalized additive models for location scale and shape. *Journal of the Royal Statistical Society*, 54(3), 507-554 (2005).
23. Stasinopoulos, M. D., Rigby, R. A. Generalized additive models for location scale and shape (GAMLSS) in R. *Journal of Statistical Software*, 23(7), 744-763 (2007).

24. Weron, R., Misiorek, A. Short-term electricity price forecasting with time series models: A review and evaluation. In Mielczarski, W. (Ed.), *Complex electricity markets*, 231-254 (2006).
25. Weron, R., Misiorek, A. Forecasting spot electricity prices: A comparison of parametric and semiparametric time series models. *International Journal of Forecasting*, 24, 744-763 (2008).
26. Weron, R. Electricity price forecasting: A review of the state-of-the-art with a look into the future. *International Journal of Forecasting*, 30(4), 1030-1081 (2014).
27. Wood, S. N. *Generalized Additive Models: An Introduction with R*. 2nd ed. Chapman & Hall, London (2017).
28. Ziel, F., Steinert, R., Husmann, S. Efficient modeling and forecasting of electricity spot prices. *Energy Economics*, 47, 99 (2015).

# Budgeting Integration with a Business Strategy and Accounting System in Business Process Management - Case Study of Ukrainian Company

Viktorija Yatsenko<sup>1</sup>, Yevhen Kudriavets<sup>2</sup>

<sup>1</sup>Kherson National Technical University, 24, Beruslavske st., Kherson, 73008 Ukraine  
viktorijajacenko@gmail.com

<sup>2</sup>Taras Shevchenko National University of Kyiv, 90-A, Vasulkivska st., Kiev, 03022  
Ukraine  
ykudriavets@gmail.com

**Abstract.** A client, quality and time should become the priority targets of the company's budget process in the post-industrial era. Therefore, sales of products should be priority process rather than production process. Moreover, budgeting is no longer a function of a separate department, but transforms into a cross-functional process. In order to model the business process «Implementation» based on the previous description we used the concept of BPM and the tools of the Workflow class. Budgeting becomes more integrated into the company's general information system rather than ever before, since budgets for the next calendar year include target indicators which are oriented to implementation of the business strategy, also they establish direct link and feedback with accounting system data, analysis and controlling. This approach presupposes the responsibility of specific executors and timing of implementation, it can be promptly managed and evaluated as a business process. The value of the BP «Budgeting» is to provide concrete recommendations to practitioners and identify open research areas for academics, thereby expanding and enriching traditional frameworks of BPM. Nowadays, budgeting is not one-time and coordinated set of actions but rather a transparent, easy-to-transform, integrated business process that contributes to the company's strategic growth.

**Keywords.** budgeting, business process, budget sales, accounting system, business strategy, workflow.

## 1 Introduction

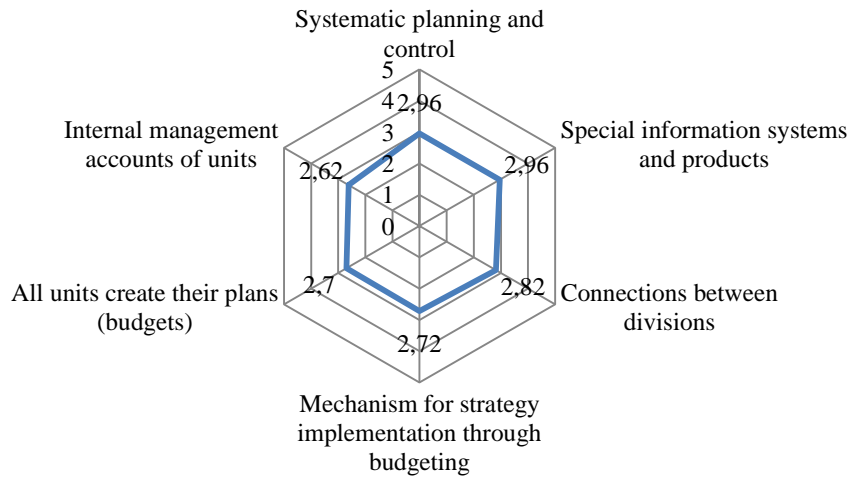
To scope out the state and development of budgeting as an element of the management system in Ukrainian enterprises, we have used some results of the analytical report [1].

The results confirm that budgeting and strategic planning are the most widespread management technologies among Ukrainian companies. We have noted the growth of interest in budgeting compare to the previous period by 42%. However, at a time of significant increase in the use of process management to 43%, compared with the



previous 15%, business process reengineering has dropped almost twice from 48% to 27%.

Averagely, the degree of acceding to submission that a company has both systematic planning and control (annual or quarterly) is 2.96 (Fig. 1).



**Fig. 1.** Average rating of acceding to following submissions (5-grade scale) [1]

A low score of 2.7 points reflects that in companies about half of all units form their plans (budgets), which are supervised by management. Also, not all divisions record internal management reporting (2.62 points). The existence and implementation of the relationship (information flows, responsibility, authority) between the divisions were assessed only in 2.82 points. A mechanism for a company strategy implementation through the tasks for subdivisions and the development of budgets were estimated at 2.72 points. Special information systems and products are widely used by companies for information processing (2.96 points).

Furthermore, according to a recent research with some large Fortune companies by Wixom and Beath (2014), obstacles for firms to realize expected value from their data initiatives include: lack of common data platform and missing or broken business processes to support the common data platform, lack of user engagement, and lack of leadership or commitment for required change; and their suggestions for addressing these identified barriers are: having user-centric development (i.e., actively engaging users to develop tools and services), developing hybrids on staff (i.e., proactively nurturing business-savvy IT people and IT-savvy business people), and marketing internally (i.e., aggressively marketing and selling the value of data) [2, p. 37].

Therefore, despite the leadership of strategic planning in the rating of managerial technologies over a long period of time, solution of short-term tasks through annual budgets development and analysis of their implementation is still priority of management. Due to the high turbulence of the external environment, strategic

management is losing its value in the management and owners of the company. Even in case of a strategy, mechanisms for controlling its implementation through the development of annual budgets and recording are not always applicable or ineffective.

Process management displaces the traditional (functional) one. At the same time, harmonisation and business processes reengineering disappear from the list of popular management technologies, which is risky, taking into account active implementation of information systems, since customer company of software usually has responsibility for business process architecture. There is a popular misprediction that if information system exists it can solve all major problems. It is one of the main reasons why company's automation projects are ploughed.

The purpose of the article is to present budgeting as an element of a business process management system integrated with a business strategy and accounting system, incorporated into a workflow. The paper will help to understand better the business objectives of a company for further business processes modelling.

This stems from the need to address the following tasks:

- 1) to build a budgeting model as a business process using tools of the Workflow class;
- 2) to minimize incoming information flows based on mobile and flexible modelling;
- 3) to consolidate and detail the outcomes of the business process.

## **2. Related Works**

The change of the priority direction in management from the production sphere to the sale of products is the main characteristic of the post-industrial stage of society's development. For instance, prof. El-Kelety (2006) says that focus on customer (a Greater Focus on the Customer) is one of the important trends in the development of modern business. He highlights three strategic criteria, which are in the limelight of modern companies: customer, quality, and time [3 p. 12].

Traditional concepts and management theories of the industrial age were based on a functional approach, but it became ineffective in a dynamic and changing world, which requires calculating of every step in achieving the goals. Gradually academic community and practices have moved to more rational and expedient approach – process approach. In these conditions, methods of cost accounting ABC, ABB method of budgeting, as well as the concept of ABM in management emerged and developed. The process approach was known at Taylor's time (1998) [4], but the most popular it became within the framework of TQM philosophy (Total Quality Management).

The BPR concept (Business Process Reengineering) developed by M. Hammer and D. Champi (1993), was based on the process approach [5], which later became a basic concept for Business Process Management (BPM).

Author believes that the most comprehensive work about BPM is popular book written by Jeston J. & Nelis J. (2014) [6], which saw three editions. Paim, Caulliriaux, & Cardoso (2008) say that BPM includes components of total quality management (TQM), the value chain, Six Sigma, Lean, and enterprise resource planning (ERP) [7]. Jan vom Brocke, Theresa Schmiedel, Jan Recker, Peter Trkman, Willem Mertens, Stijn Viaene, (2014) characterize BPM as a research domain and guide its successful

use in organizational practice [8, p. 530].

There are three main directions of BPM:

- Efficiency of major companies' business processes, such as supply, production, sales and marketing [8-11];
- corporate philosophy (culture) of BPM [12-13];
- the use of information technologies for BPM implementation [14-15].

Serving business processes are out of eyeshot of many researchers, in particular budgeting, and their connection with the strategic goals of a company. The purpose of this study is to address this research gap.

Investigation of BPM done by Ukrainian scientists and its practical application by enterprises is at an early stage.

It should be noted, that the orientation to the production process was in evidence for all national economies of the industrial area. The revival of Ukrainian industrialization concurred with the Soviet regime that is why state multilevel centralized planning dominated so many decades which was based on rigid resource standardization, while consumer demand and inquiries were ignored. Now we can assess how difficult the situation was for Ukrainian enterprises at the end of the twentieth century because they had to work in conditions of completely destroyed political system and transitional period not only to the market economy, but also to the post-industrial era. New conditions dictated alternative measures for survival of enterprises in the market competition.

One of the tools of a market economy that enterprises have had to master is budgeting, which is being analysed through the studying, adapting and implementing foreign experience. Therefore, the most common areas of budgeting research among Ukrainian scientists are:

- theoretical aspects [17-21];
- introduction of budgeting in Ukrainian companies [22-26].

S. Y. Bersutskaya and O. O. Kamenskaya insist on the importance of including strategic goals into the budget process: «The lack of a link between the budgeting system and the company's strategy is the reason of the ineffective motivation of the heads of departments and their employees to achieve the strategic goals of the enterprise» [27, p. 145].

Coming to BPM in a Ukrainian company evolutionally is described in details in [28].

Great majorities of academic texts are limited to clarifying the theoretical foundations; however, modern companies extremely need work with specific recommendations for the implementation of the theory into real practice.

### **3. Business Process «Budgeting»**

In the Ukrainian company, which is under our study, the business process methodology was not well developed. Traditionally, budgeting practices were focused on planning and controlling of sales by product types in terms of costs incurred for its production and sales, not taking into account specific of sales channels, which diversifies cost structure. Ignoring budgeting, accounting and cost analysis at the level of sales channels necessarily led to the loss of control over the total costs of the

product sales process. Uncoordinated forms of budgets of different divisions became a following problem of the company's budgeting system.

Restructuring of the "Budgeting" business process aimed at creation of a stable tool of data aggregation for coordination business strategy and actual accounting system data suitable for controlling procedures by a controlling department. In other words, the methodology for generating the required budget indicators had to harmonize simultaneously the indicators of the business strategy and databases formed in the accounting system. As well, to establish the relationship between the elements of the management system, budgeting, strategic management and accounting system which are considered as data sources.

The next task of the BP is to develop a procedure for compiling budgets and managerial reporting forms, key figures of which correspond with indicators of business strategy and financial reporting forms, compiled according to generally accepted accounting standards. The procedure provides for the responsibilities, executors and terms of execution. The solution of the existing problems has become a key task after the management's decision to automate the budgeting process.

The presented budgeting approach is described at the same time as an element of the company's general information system and as a separate business process that recycles inputs into outputs in order to make budget adjustments quickly and ensure company's growth in the long run period.

The demonstration of the BP "Budgeting" includes the following sequence:

*1. Budget process design (Budget process)*

*1.1. General scheme (Overview)*

*1.2. Budget process - workflow steps*

*1.3. Chart of process timetable*

*2. Input*

*2.1. Budget sales*

*2.2. Finance*

*2.3. Controlling*

*3. Output*

*3.1. Budget Reporting package*

*3.2. Budget presentation*

Let's consider each item in detail.

*1. Budget process design*

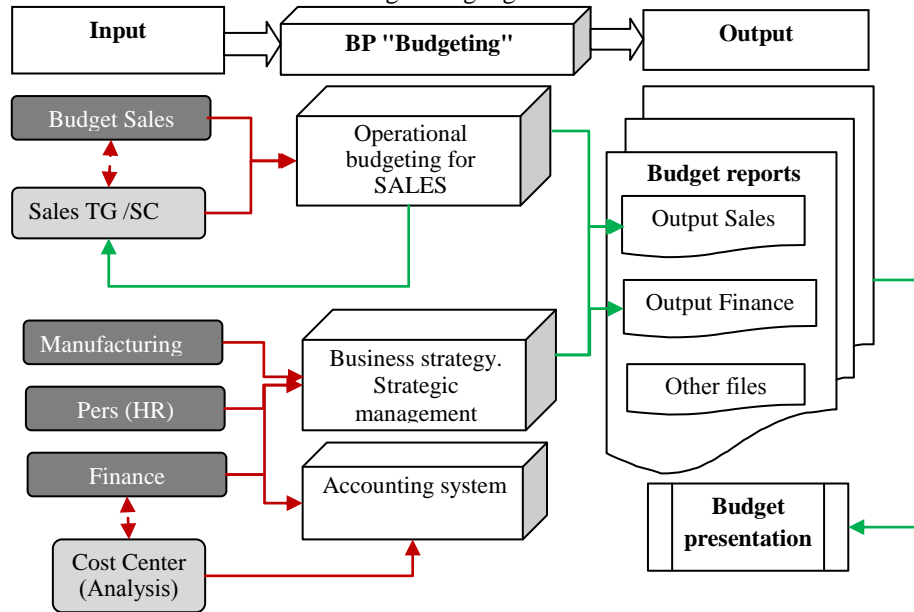
*1.1. General scheme (Overview) (fig. 2).*

Figure 2 illustrates the integration of strategic management units (business strategy) and company accounting system into the overall architecture of the BP "Budgeting", which allows to align each annual budget with the goals of the company's business strategy and rely on actual accounting data.

A specific feature of the approach is the creation of additional budgets of target product groups (TG) and sales channels (SC). Channels include Channel Retail, Direct Sales, Channel Dealer, Channel Web. Since e-commerce is being used more and more widely in the post-industrial era, it makes sense to monitor channels in two directions of B-to-B and B-to-C to determine the most cost-effective.

Therefore, the process approach of the BP "Budgeting" design details the strategic objectives to the cost centre, determines the impact of each of them on the volume and structure of the spent resources, the integration of the accounting system, analysis

and control, establishes an adequate allocation of responsibilities among the owners of the BP. Thus, process approach of the budgeting design focuses on cross functional processes, unites the functions of various departments and services into a general information flow aimed at achieving strategic goals.



**Fig. 2.** Overview of the BP “Budgeting”

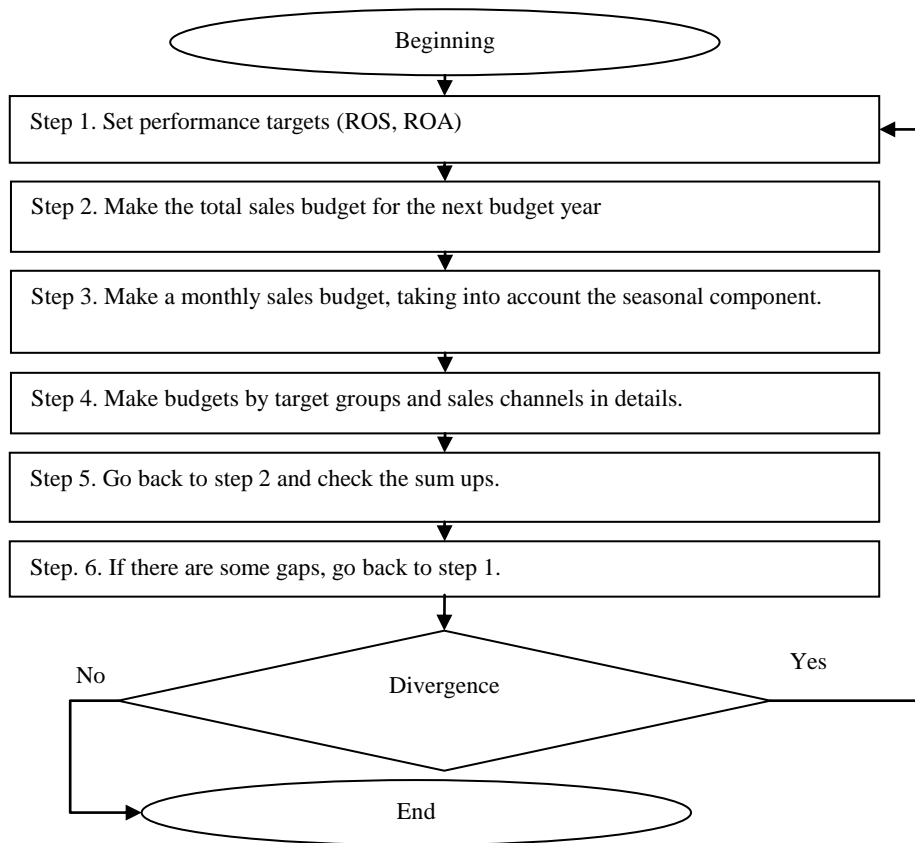
*1.2. Budget process- Workflow steps*

The regulation of the BP “Budgeting” based on the WF includes: the procedure of operational and financial budgets formation, the analysis of the external environment and the establishment of business strategy goals, the timing of data entry and its processing, functions, responsibilities and organization of interaction between units and participants in the budget process.

The budget process can be divided into three blocks. Let's consider them in details. Figure 3 shows an indicative step-by-step algorithm for compiling operating budgets.

The algorithm demonstrates steps of operational budgets drafting created for Workflow, and defines ways for routing. It also establishes the relationship between the steps of Workflow based on exit values. For example, total sales budget for the next budget year is the output of the first step of Workflow. Whereas, the output of each step of Workflow creates its own data path of operational budgets. The algorithm defines how the project architect should simulate the process of operating budgets drafting and integrate Workflow steps into the BP “Budgeting”. The implementation of the algorithm will enable to organize Workflow and ensure successful completion of operational budgets to the fullest extent.

The next block of the BP “Budgeting” provides for an analysis of the external environment and the strategic phase of the budget process.



**Fig. 3.** Algorithm for operational budgets drafting of the project Workflow in the "Budgeting" BP

**Block II Analysis of the external environment and the strategic phase of the budget process**

Step 1. Analysis of the current situation

Organising a strategic phase in the budget process.

Step 2. Formation of the target picture based on the company's business strategy, usually for the next five years, taking into account the results of SWOT-analysis

Step 3. Establishing financial and non-financial indicators of the company's development for the next five years, including the budget year (Gross Sales, Operating result, Pre-tax result, Post-tax result, ROS, ROA, I / C Liquidity, Total Assets, Investments, Headcount, FTE-K)

**Block III. Financial budgets**

Step 1. Analysis of relevant information, comparing usually, actual data for the 9 months of the current year with similar data for the past budget year.

Step 2. Make profitability calculation

Step 3. Calculate the key indicators of the cost centres

Step 4. Make a profit and loss budget, specified expenses budgets and financial

results.










Step 5. Make a balance sheet budget

Step 6. Make a cash flow budget

*1.3. Process Timetable*

Process Timetable (table 1), using Workflow class tools, will make each step of the budget process specific and transparent, also will define precise timelines for execution and reporting. Each particular company, based on the submitted form, can add specific performers and responsibilities in order to eliminate the lack of responsibility.

**Table 1.** Process timetable of BP “Budgeting”

BUDGET PROCESS							
	WORKFLOW STEPS	Month					
		July	Aug	Sept	Oct.	Nov.	Dec.
	1. Formation of input information						
	2. Data entry						
	3. Budgets formation						
	4. Preliminary presentation of operational budgets		<b>17.08</b>				
	5. Preliminary presentation of financial budgets		<b>25.08</b>				
	6. Discussion of budgets within BPM						
	7. Making changes in budgets					<b>05.11</b>	
	8. Preparation of the budget for cost centres						
	9. Approval of budgets by the Supervisory Board					<b>25.11</b>	
	10. Presentation of the approved version of the budgets						<b>01.12</b>
	11. Familiarization staff with the budgets for the next year						 

## *2. Input*

### *2.1. Budget Sales*

Only actual data can be as an input for BP “Budgeting” received from the company's accounting system in the necessary analytical sections. The overall sales budget is based on the accepted business strategy and established financial and non-financial indicators of growth for a period that includes the budget year and the subsequent four years. The next form of budget is a specific monthly sales budget for the following year, taking into account the seasonal component. At the level of the general budget, sales are represented by target groups of products that form product types with individual articles and similar functionality. Types of products that are not included in a specific target group are grouped in the “Others”. Simultaneously sales budget is made at the level of sales channels by target groups with establishing a direct relationship with generalizing indicators of the general budget.

All calculations are based on normal prices. While special promotions and offers for individual regions and clients are considered after approval by the Group Controlling of the company.

### *2.2. Finance*

The dominance of accounting for financial reporting according to general accounting standards is observed not only in Ukraine. Accounting data, even if it based on actual data, is often distorted in order to optimize taxation, what bars the company's management from the possibility to operate information for management. However, the language of accounting is the «Esperanto» of business, the base category, in accordance with not only accounting, but also the control and analytical component of management are built. That is why, all the options of interpreting the accounting data within the variety of management concepts, theories and decisions are based on the non-alternative accounting system, which provides collection, fixation and summarization of factual data of the company's activities for preparation of financial statement. The effectiveness of the company's accounting system is determined, first of all, by the possibility of the accounting data analysing obtained from the financial accounting with multi-level managerial levels.

The analysis of current information provides for the compilation of two synchronized Profitability Calculations by target groups and sales channels. Actual data for the compilation of both forms is obtained from the company's accounting system by the relevant analytical sections. The main purpose of the actual information analysis is the identification of profitable and unprofitable types of products and sales channels. To makeup Profitability Calculation it is better to use the method of the margin income determination, but the value of the conclusions and the situation assessment will depend on an adequately organized and normally functioning accounting system of the company, including a properly integrated management accounting module in the financial accounting system. The management accounting module should provide for the data about the variable and fixed costs of each cost centre. Traditionally, cost centres are allocated in the production process. This study focuses on the priority of the process implementation, therefore, we propose to identify sales channels as cost centres whose costs are classified as direct and indirect. This will allow to analyze the profitability of each channel and evaluate the performance of specific employees.

The positive result is achieved through the coordination of two oppositely directed



informational flows. The first flow generates targets that go to costs centres down from the top in the form of strategic indicators. Vice versa, the second flow adjusts the corporate strategy raising information from bottom to top, guided by the actual data obtained at the level of cost centres within the operational management, and establishes a direct and unambiguous connection with the company's development strategy.

The analysis of current information and its comparison with similar data of the past year allows to set target non-financial growth indicators based on real tendencies of increase or decrease in sales volumes of certain product types forming target groups and outlines the necessary measures for increasing the efficiency of sales channels.

The Profit & Loss budget calculates planned financial results by type of activity (operational, financial, investment). Typically, there is an ambition to increase profits by increasing revenue from sales and other income and minimizing costs, but strategic management makes its own adjustments. For instance, a business strategy means expanding a specific market sector, which requires staff and costs increase. Additional costs will be justified if they receive the required level of revenues for a certain period, that is why the budget indicators are based on the analysis of quantitative data for the past years and expert estimates of the possibilities of increasing revenue for a business strategy implementation.

The next step is to detail the budgets of Personnel Expenses and Headcounts, Depreciation and Investments, other operating expenses (Administration, Marketing, Distribution) and the calculation of the planned Financial Result for the next fiscal year.

In order to make up a budget Balance Sheet, actual reporting data for the previous three years is used. In this case, it is advisable to use company's accounting records that are summarized for the financial reporting according to generally accepted accounting standards (national, IFRS). The emphasis is on relevant balance sheet items for each specific company.

The final form of financial budgets is Cash Flow, which defines the net cash flow by type of activity (operational, investment and financial) and net cash flow.

Consequently, the financial budgets involve handling the input data obtained from the accounting system (financial and management accounting), submission of the relevant articles of the monthly financial statements in details. All forms of financial budgets necessarily make up for each business unit. The organization of accounting provides formation of credential database in terms of value at all necessary levels in close integration with the BP "Budgeting" and becomes a prerequisite, as well as a criterion of sufficiency and consistency.

### *2.3. Controlling*

The task of control and analysis is to obtain information about the effectiveness of the business unit activity as well as the centres of responsibility in achieving the planned results and targets and also the reasons for failure of budget indicators.

Controlling Budgets can include three major budgets:

- personnel;
- manufacturing;
- controlling and analysis;

As the efficiency of using the knowledge and competencies of the company's staff

is a priority of modern management concepts, therefore Controlling Budgets / Personnel are identified to control and analyse a business strategy implementation of human resources management, mainly in the area of the costs incurred in training and upgrading the company's employees. However, if this information is contained in other financial budgets, it is advisable not to duplicate the information and leave information in all details for relevant HR sections.

The theoretical model of production budget is rather well known, but in practice there is no single methodology for compiling a production budget package. The budgeting of the production process is influenced by the features of technology, cost structure, assortment product, and organizational structure of the company, and the most important aspect is the inclusion of a production division in a business unit or as a separate unit with its own balance sheet. In the presented example, it is considered that a structural unit engages the production, which is classified as a separate business process with its own cost centres. A separate budget and schedule of production are formed after the approval of sales budgets.

The directions of the company's revenue and expenditure analysis will depend on the company's growth stage. It can be both maximizing incomes and minimizing costs. Since the high level of indirect costs in the overall cost structure is common characteristic of many companies which operate in the post-industrial era, in most cases the analysis is aimed at identifying and eliminating unproductive indirect costs.

With this view, costs are divided into direct and indirect according to not only specific types (target groups) of products, but also sales channels, which are recognized as cost centres in the business process «Realization». Thus, a variable and constant parts are identified within direct and indirect costs according to the activity driver. In this way, concept of ABM / ABC / ABB is implemented.

### *3. Output*

#### *3.1. Package of report forms*

Package Budget reports includes:

Content:

- Sales and COS
- Key Indicators
- Profit and loss comparison
- Other expenses
- Balance
- Headcounts
- Investments
- Cash flow statement
- Key Indicators MRP

BP “Budgeting” provides wide opportunities for forming a package of report forms at all levels of management (strategic, tactical, operational) due to the high integration of subsystems into the company's information system, minimizing of incoming information, tools for consolidating and detailing input and output data, mobile and flexible modelling tools.

#### *3.2. Presentation*

The last, but not least, stage of the budget process is the presentation of a report forms package for the company's management and staff. It is desirable to present using modern tools and technologies.

Forms of operational and financial budgets are the basic material for slides. It is necessary to use the analysis results and arguments in support of the planned activities for the next fiscal year. Information should be available for understanding. A presentation will be effective if each performer has a clear idea “What” he should do and a specific instruction «How».

## 4 Conclusions

The presented approach considers budgeting within the framework of the BPM concept at the same time as an element of a complex open information system of the company and as an “end-to-end” business process. Thus it extends to multifunctional units and services aimed at achieving the strategic objectives of the business unit.

The presented BP “Budgeting” of the company's activity allows to integrate data into a single information flow of planned (budget) and actual data of the company's accounting system, including financial and management accounting. It can be used as a base regardless of the type and characteristics of the company's activities and size. The proposed design can become a roadmap for the reengineering of the existing company's budget process.

Based on the WF, this approach allows to use effectively time of the participants of the BP “Budgeting”, which helps them to focus on the ability to quickly adjust budgets in order to accelerate the achievement of target performance indicators and identify benefits for the quick business strategy implementation. The practical value of the approach means using it as a foundation in regulations development of the BP «Budgeting» in order to form a hierarchical responsibility system, personification and control of procedures and actions of specific performers with clear deadlines and terms at each step of the process, which guarantees high business process performance. Detailing WF of the BP “Budgeting” provides a convenient quickly respond to dynamic changes in the external and internal environment and adapt to new operating conditions.

The research demonstrates the organization and method of budgeting the best quality with low cost. This model will provide a direct and indirect link between strategic, tactical and operational management levels, using a long time horizon for development goals assessment, between top management and cost centres. The research is based on the dominant view of modern scientists on the activities reorientation of companies on the client, quality and time in the post-industrial era.

Recommendations have practical benefits to companies in case of a management decision to introduce information technology into the budgeting process.

## References

1. Investigation of the state and trends of Ukrainian enterprises development. Analytical report for 2014/15, [https://kneu.edu.ua/userfiles/project\\_1314/DoslD196dzhennya\\_suchasnogo\\_stanu\\_ta\\_tendencD196D197\\_rozvitku\\_ukraD197nskih\\_pD196dpriD194mstv\\_2014-15.pdf](https://kneu.edu.ua/userfiles/project_1314/DoslD196dzhennya_suchasnogo_stanu_ta_tendencD196D197_rozvitku_ukraD197nskih_pD196dpriD194mstv_2014-15.pdf)
2. Jun X.: Managing Digital Enterprise: Ten Essential Topics (2014),

<https://www.springer.com/gp/book/9789462390935>

3. El-Kelety, L.: Towards a conceptual framework for strategic cost management .The concept, objectives and instruments. PhD thesis. Chemnitz, Germany: Chemnitz University of Technology (2006).
- 4.. Taylor, F. W.: The Principles of Scientific Management. Dover Publications (reprint of 1911 original) (1998).
5. Hammer, M. and Champy, J. A.: Reengineering the Corporation: A Manifesto for Business Revolution, Harper Business Books, New York (1993).
6. Jeston, J., & Nelis, J.: Business Process Management: Practical Guidelines to Successful Implementations. Butterworth-Heinemann, Oxford (2014).
7. Paim, R., Caulliriaux, H. M., Cardoso, R.: Process management tasks: a conceptual and practical view, *Business Process Management Journal*, Vol. 14 Issue: 5, pp. 694-723 (2008), <https://doi.org/10.1108/14637150810903066>
8. Brocke Jan vom, Schmiedel, T., Recker, J., Trkman, P., Mertens, W., Viaene, S.: Ten principles of good business process management, *Business Process Management Journal*, Vol. 20 Issue: 4, pp. 530-548, (2014), <https://doi.org/10.1108/BPMJ-06-2013-0074>
9. Pradabwong, J., Braziotis, C., D.T. Tannock, J., S. Pawar, K.: Business process management and supply chain collaboration: effects on performance and competitiveness, *Supply Chain Management: An International Journal*, Vol. 22 Issue: 2, pp. 107-121, (2017), <https://doi.org/10.1108/SCM-01-2017-0008>
10. Kaemsap, K.: Mastering business process management and business intelligence in global business. In *Global Business Expansion: Concepts, Methodologies, Tools, and Applications*, pp. 76--96. IGI Global (2018).
11. Rosemann, M., de Bruin, T.: Towards a business process management maturity model. *Proceedings of the 13th European Conference on Information Systems (ECIS 2005)*, Regensburg, 26--28 May 2005. ECIS, (2005).
12. Jan vom Brocke, Sinnl, T.: Culture in business process management: a literature review, *Business Process Management Journal*, Vol. 17 Issue: 2, pp. 357--378, (2011), <https://doi.org/10.1108/14637151111122383>
13. Schmiedel, T., vom Brocke, J., & Recker, J.: Culture in business process management: how cultural values determine BPM success. In *Handbook on Business Process Management 2*, Springer, Berlin, Heidelberg, pp. 649--663, (2015).
14. Kumar, A.: *Business process management*. Routledge, (2018).
15. Rinderle-Ma, S., Toumani, F., Wolf, K. (Eds.): *Business Process Management: 9th International Conference, BPM 2011, Clermont-Ferrand, France, August 30-September 2, 2011, Proceedings (Vol. 6896)*. Springer, (2011).
16. Scheer, A.-G., Abolhassan, F., Jost, W. and Kirchmer, M.: *Business Process Change Management*. Springer, (2003).
17. Pilecka S.T., Protsyuk D.V.: Formulation of the budget system in the aviation enterprises. *News of Economics of Ukraine (Visnyk ekonomichnoyi nauky Ukrainy) № 2 (31)*, pp. 153--157, (2016).
18. Pyatnychuk, I.D.: Approaches systematization to the definition of budgeting principles and methods. *Scientific and Information Bulletin of the Ivano-Frankivsk University of Law named after King Danylo Halytskyi (Naukovo-informacijnyj visnyk Ivano-Frankivskogo universytetu prava imeni Korolya Danyla Galyczkogo)*, 12, pp. 228-236, (2015).
19. Merenkova, L.O., Matyushenko, O.I.: Types of company budgets and budget planning methods .*Communal economy of cities (Kommunalnoe xozyajstvo gorodov)*, 77, pp. 381--388, (2007).
20. Gnip, N.A.: Organizational-managerial bases of financial planning at the enterprise. *Economic Annals-XXI (Ekonomichnyj chasopys-XXI)*, 2 (1-2), pp. 35—38, (2015).
21. Zakharchenko, S.V.: World experience of budgeting in the system of financial management of enterprises: prospects of use in Ukraine (Doctoral dissertation, Vinnitsa, VNNIE TNEU), pp.

- 43--45, (2017).
22. Prots N.V.: Features of the implementation budgeting system process. Investments: practice and experience (Investytsiyi: praktyka ta dosvid), 16, pp. 89--92, (2015).
23. Golovatskaya S., Popovich, M.: Methodological and organizational aspects of budgeting by the centers of responsibility of enterprises for the production of beer. 6. Economic Discourse (Ekonomichnyj dyskurs), 4, pp. 36--42, (2017).
24. Pozhuva, T. O.: Budgeting as a direction to improve the management of enterprises. Journal of Economic Science of Ukraine (Vestnyk ekonomycheskoj nauky Ukrainy), 1 (32), pp. 73--77, (2017).
25. Artem, P.: Project-based budgeting in shipbuilding enterprise. *Skhid*, (1), (2014).
26. Ostapenko Y.: The system of budget management in the management of the main organization of water transport. Accounting Region and Audit (Buxgalterskyj oblik i audyt), 12, pp. 41--47, (2015), [http://nbuv.gov.ua/UJRN/boau\\_2015\\_12\\_7](http://nbuv.gov.ua/UJRN/boau_2015_12_7).
27. Bersutska, S.Y., Kamenska, O.O.: Methodical approach to the strategic budgets compilation of the industrial enterprise. Economy Management: theory and practice: St. sciences. etc. - K. : IEP NANU (Upravlinnya ekonomikoyu: teoriya ta praktyka: Zb. nauk. pr.), pp. 144--150, (2015).
28. Yatsenko, V.: Ukrainian Company Cost Accounting System Development from the Evolutionary Theory Position. In: Proceedings of the 14th International Conference on ICT in Education, Research and Industrial Applications. Integration, Harmonization and Knowledge Transfer, Kyiv, Ukraine, 14--17 May 2018, vol. 2104, pp. 207--221 (2018)

# Can Information Technology Increase Government Effectiveness?

Tetiana Paientko<sup>1</sup>[0000-0002-2962-308X] and Viktor Fedosov<sup>2</sup>[0000-0003-1092-4218]

<sup>1</sup> Kyiv National Economic University named after Vadym Hetman, Peremohy avenu 54/1, Kyiv 02000, Ukraine  
tpayentko109@gmail.com  
finance\_kneu@ukr.net

**Abstract.** The article deals with government effectiveness in central and eastern European countries. In 1990, eastern European countries began to transition from communism to free market capitalism. After more than twenty years of reform, central and eastern European countries are showing different results in economic development because of widely contrasting levels of government effectiveness. Recently government effectiveness was tied to e-governance services and their growth. The purpose of the article is to analyze how information technology can increase government effectiveness.

Firstly, the main ideas of government effectiveness and its indicators were described. Secondly, trends of government effectiveness in selected countries are analyzed using R. Thirdly, impact of e-governance on government effectiveness was analyzed. Fourthly, ideas to improve government effectiveness are proposed.

The methodology of research includes both qualitative and empirical methods. The data used was from World Bank sources.

**Keywords:** government bureaucracy, electronic governance, government bureaucracy effectiveness.

## 1 Introduction

The activity of government bureaucracy in many countries of Central and Eastern Europe is considered ineffective. Ineffectiveness has become almost synonymous with the concept of "government bureaucracy." The current situation is due to several factors. Firstly, the global economic situation is unstable, and this has a negative effect on the welfare of many citizens. Secondly, there was a change of political regimes and economic systems in many countries of central and eastern Europe at the end of the twentieth century. The population of these countries did not have an environment of political freedom, so personal involvement in which to give voice to their political aspirations was hindered. Moreover, public opinion could be easily manipulated using the methods of earlier days. The present-day expectations of these populations are, as a result, exaggerated concerning government bureaucratic effectiveness. Thirdly, the methodology of evaluating the effectiveness of government bureaucracy is controversial. It raises many questions. For example: What indicators can be used

and for which countries, how to consider the corruption component, and what methodology can be used for evaluation? It is impossible to investigate all the factors listed above in one article. Therefore, in this article we will focus only on the effectiveness of the activities of government bureaucracy regarding the economic condition of the country.

After the collapse of communism in 1989, all Central and Eastern Europe countries undertook reforms to transform a politicized and inefficient bureaucracy into modern professional bureaucracies. Efforts were directed towards making the government bureaucracy more efficient, effective, transparent and responsive to the needs of society. Despite this, it became apparent that in the context of political and economic change, the reform of government bureaucracy was postponed in many of these post-communist countries. In this case, for example, Meier, K. J., & O'Toole, L. J. [19], Meier, K. J. [20] raised the issue that institutional reform was made difficult by the lack of resources. Legislation to create a professional and depoliticized bureaucracy was introduced, but the legacy of the past gave rise to a reluctance to change. In addition, countries such as Hungary and Poland abolished the requirements of impartiality in their laws, thereby effectively allowing a return to politicization. As a result, it turned out that the vector of development of state bureaucracy in the countries of Central and Eastern Europe is different, and the economic results of the development of those countries are different from each other.

The importance of studying the relationship between the effectiveness of government bureaucracy and economic well-being can be explained by at least two factors. First, government bureaucracy is maintained by taxpayer money. A natural desire of taxpayers is to understand that the money paid by them is used efficiently. An additional natural desire of the taxpayers is improvement in their own welfare. This means that if a taxpayer agrees to pay taxes, he/she expects more benefit from the government. Secondly, government bureaucracy cannot be characterized as being either absolute evil nor absolute good. Its presence in the modern state is objective. However, the long-term success of the state's development depends, among other things, on how effectively its government bureaucracy manages the economy.

Starting at the end of the twentieth century, government services in many countries began moving to a more electronic format. This significantly simplifies the lives of customers of that services. As a result, it is widely believed that the introduction of electronic government services contributes to improving the effectiveness of government bureaucracy. In our opinion, such conclusions need to be confirmed by empirical results.

The purpose of the article is information technology can increase government effectiveness.

The paper is organized as following:

1. The second part is devoted to a literature review about government effectiveness in general, and the role of informational technologies (e-governance) at present.
2. The third part describes the methodology of the research and sources of data.
3. The results of the calculations and their discussions are presented in the fourth part.

## 2 Literature Review

Effectiveness is a multi-faceted concept, the various elements of which are not always consistent with each other. The complexity of assessing the effectiveness of government bureaucracy is due to at least two factors. First is the subjectivity of assessing the role and necessity of bureaucracy from the point of view of society. Secondly, the effectiveness of the bureaucracy is closely related to the effectiveness of its management. The effectiveness of management is associated with the behavioral aspects within the activities taken by the representatives of the government bureaucracy, which is difficult to assess using quantitative indicators. Therefore, publications devoted to problems of the functioning of government bureaucracy and its effectiveness take several forms.

Some publications are devoted to the historical aspect of bureaucracy development and its connection with the formation of modern models on the functioning of society (Monnier F., Thuillier, G. [21]; Ungureanu, D.M. [29]).

The turn of the twenty-first century was marked by an exacerbation of the problems of the effectiveness of bureaucracy. This led to a growing interest in the institutional approach, in which economists have paid increased attention to the principles of effective management. This concept is explored in the publications of Kaufmann D. [15] and Knack S. and Keefer P. [16]. Researchers have focused on the role of institutions in ensuring economic development, organizing effective management of institutions and preventing ineffective increases in their number.

Many studies over the past ten years have been devoted to the problems of political interference in the activities of bureaucracy (Nath, A. [22] and Rogger, D. [27]). Also, researchers are trying to assess how expensive it is for society to finance the activities of bureaucracy and how effective it is (Ravishankar, N. [26]). Also interesting are studies that are devoted to assessing the risks of the dominance of individual interests of bureaucracy over public ones (Lipsky, M. [17] and Mansuri, G. and Rao, V. [18], Fafchamps, M., and Labonne, J. [8]). The growing interest in the issues listed above is due to the increasing desire of large business representatives to engage in politics.

Ukrainian researchers are more interested in the role of bureaucracy in politics (O. Tsapko [28], O. Batrimenko [2]), the functions of modern bureaucracy and problems of its development in Ukraine (G. Yakovenko [30]), and the losses to society as a result of the low effectiveness of Ukrainian bureaucracy (Paientko and Fedosov [9]).

The politicization of government bureaucracy is not only a problem for the countries of Eastern and Central Europe. This is evidenced by studies by western researchers in assessing the performance of government bureaucracy (O'Toole, L. [23]), and assessing the impact of government bureaucracy on economic growth (Evans, P., and Rauch, J.E. [7]). Researchers are also trying to determine the best path for the development of state bureaucracies in post-communist and developing countries (Goetz, K.H. [11]; Rauch, J.E., and Evans, P.B. [7]).

Many researchers believe that the introduction of more online government services for citizens is one of the factors driving government effectiveness. This will reduce the direct contact with government officials, which means that the risk of corruption will decrease. As Gronlund, A. [13], points out, since e-government is citizen-



oriented, it will provide greater accountability for government operations and, as a result, will increase the confidence in a government by its citizens. Garson, D.G. believes that increasing the effectiveness of government bureaucracy as a result of the introduction of e-government will be due to improved interaction between different government structures, which will facilitate faster decision-making [10].

Kamarck, E.C. and Nye, J.S. believe that the spread of electronic government services contributes to reducing overhead costs, helps to avoid duplication of functions of various government structures, reduces the cost of providing public services and provides easy access for citizens to e-Government services. In addition, government services become accessible anytime and anywhere [14]. Paientko T. [24] proves that using GIS in public finance reforms can increase accountability and trust in government.

Currently, there are very few systematic studies that would show how the spread of electronic government services affects the effectiveness of the government bureaucracy. Most of the papers are aimed at assessing consumer satisfaction with e-government services (Bretschneider, S., Gant, J. and Ahn, M., Chen, Z. and Dubinsky A.J. [5], AJ, Criado, and Ramilo, M.C. [6]), or devoted to an assessment of the implications of e-government in certain countries (Beynon-Davies, P. and Williams, M.D. [4], Criado, J.I., and Ramilo, M.C. [6], Asgarkhani, M. [1])

### **3 Methodology**

One of the first questions of methodology is to determine which countries indeed belong to the countries of Central and Eastern Europe. There are different opinions. We adhere to the approach that the United Nations uses, which includes Austria, Hungary, Germany, Liechtenstein, Poland, Slovakia, Slovenia, the Czech Republic, Switzerland, Belarus, Russia, Romania, Bulgaria, Moldova, Ukraine, Croatia, and Serbia. Liechtenstein was excluded from the sample, as all the necessary indicators for this country are not available.

A difficulty in assessing bureaucracy effectiveness is caused by the lack of a common approach to define the essence of bureaucratic effectiveness, and therefore the choice of indicators. Although many researchers consider that it is controversial to gauge the effectiveness of government bureaucracy quantitatively, we agree with Groeneveld, S., Tummers, LG, Bronkhorst, B., Ashikali, T., & Van Thiel, S. [12] that quantitatively assessing the effectiveness of the government bureaucracy is not only possible but necessary.

A comparative assessment of the effectiveness of government bureaucracy was carried out using the indicators of Governance and Institutional Quality, which are published by the World Bank. These indicators are publicly available and allow cross-country assessments.

Since the result of activity of government bureaucracy is the economic situation of the country, the indexes of economic freedom that characterize freedom from corruption, the protection of property rights, and the attractiveness of a country for invest-

ment and business are taken as the resulting indicators. This data is also publicly available and allows cross-comparisons.

GDP per capita was chosen as the indicator that shows the level of economic development of the country.

For evaluation of the impact of e-governance on government effectiveness, the government online service index was used (available from World Bank report). The calculations of the index were started from 2012, which is why the number of observations for this indicator is smaller. Also, Belarus was excluded from further calculations, because information about the government online service index is not available for this country.

The study states several hypotheses.

Hypothesis 1. Increasing the effectiveness of government bureaucracy has a positive effect on the dynamics of GDP per capita.

Hypothesis 2. Government effectiveness depends on control of corruption, political stability, regulation quality, rule of law and accountability.

Hypothesis 3. Government effectiveness, control of corruption, political stability, regulation quality, rule of law and accountability depends on government online service index.

The analysis was carried out using R software. Four models were used for the analysis, specifically: pooling, random, within, and between.

## 4 Results and Discussions

### 4.1 Testing the Impact of Government Effectiveness on GDP Growth

The study used panel data consisting of indicators for sixteen countries for the years 2002-2017. According to the first hypothesis economic growth (GDP per capita) depends on government bureaucracy effectiveness. The dependent variable is GDP growth per capita (GDPGROWTH). The independent variables are:

CONTROLCORRUPTION – control of corruption;

GOVERNEFF – government effectiveness;

POLISTAB – political stability;

REGQUALITY – quality of regulation;

RULELAW – rule of law;

ACCOUNTABILITY – accountability.

The results of testing the first hypothesis are presented in Table 1.

**Table 1.** Results of the Testing the First Hypothesis

	Dependent variable:			
	GDPGROWTH			
	Pooling	Random	Within	Between
CONTROLCORRUPTION	2.7*** (0.9)	2.7*** (0.9)	7.8*** (2.0)	0.8 (0.8)
GOVERNEFF	-3.0***	-3.0***	-3.2	-3.1***

	(1.1)	(1.1)	(2.1)	(0.9)
POLISTAB	1.8*** (0.5)	1.8*** (0.5)	2.8*** (0.9)	1.3** (0.5)
REGQUALITY	2.5** (1.2)	2.5** (1.2)	-1.7 (2.2)	2.9** (1.0)
RULELAW	-4.7*** (1.4)	-4.7*** (1.4)	-9.6*** (2.5)	-1.8 (1.2)
ACCOUNTABILITY	0.4 (0.8)	0.4 (0.8)	-1.1 (1.9)	-0.6 (0.7)
Constant	3.0*** (0.3)	3.0*** (0.3)		3.0*** (0.3)
Observations	256	256	256	16
R2	0.2	0.2	0.2	0.9
Adjusted R2	0.2	0.2	0.1	0.8
F Statistic	9.2*** (df = 6; 249)	55.4***	8.6*** (df = 6; 234)	12.4*** (df = 6; 9)
Note:	*p<0.1; **p<0.05; ***p<0.01			

Source: calculated by authors, based on World Bank Data

The models are statistically significant, and the hypothesis was confirmed. This means that GDP per capita growth depends on the performance indicators of state bureaucracy. Control of corruption, government effectiveness, political stability, and the rule of law have the greatest impact on GDP per capita growth.

A comparison of the performance of the four models follows. R-sq “between” reflects the quality of the fit regression and is quite high (0.9). This means that a change in the time averages for each country has a more significant effect on each variable than the temporal variations of these indicators relative to the average.

The “within” regression allows the elimination of unobservable individual effects from the model. R<sup>2</sup> is 0.2. It can be concluded that within our model, individual differences are more pronounced than dynamic ones. This argues in favor of individual effects being viewed against the end-to-end assessment model.

Models were tested using the Wald and Hausman tests. The results obtained allow that in our case a model with fixed individual effects is suitable to be concluded.

Since both developed and developing countries were included in the sample, similar calculations were made for these two groups. The models of the developed countries are statistically significant and reveal that the growth of GDP per capita is most affected by the effectiveness of the government. However, in the developing countries, it is political stability and the rule of law that have the greatest impact on the GDP per capita.

In most developed countries, democratic traditions are strong enough to allow a society to be confident in its elected government. Taxpayer confidence in government is one of the key factors for economic growth. The developing countries that are included in the sample have long been focused on the creation and/or maintenance of communist or socialist societies. In these countries, the effectiveness of the government is much lower due to a higher level of corruption, as well as an ineffective legal system. Consequently, the test of the second hypothesis is important.

#### 4.2 Testing the Impact of Control of Corruption, Political Stability, Regulation Quality, Rule of Law and Accountability on Government Effectiveness

The second hypothesis is that government effectiveness depends on control of corruption, political stability, regulation quality, rule of law and accountability of government. The dependent variable is government effectiveness (GOVERNEFF). The independent variables are:

CONTROLCORRUPTION – control of corruption;

POLISTAB – political stability;

REGQUALITY – quality of regulation;

RULELAW – rule of law;

ACCOUNTABILITY – accountability.

The results of analysis are presented in Table 2.

**Table 2.** Results of the Testing the Second Hypothesis

	Dependent variable:		
	GOVERNEFF		
	Pooling	Random	Within
CONTROLCORRUPTION	0.3*** (0.05)	0.3*** (0.1)	0.3*** (0.1)
POLISTAB	-0.01 (0.03)	-0.03 (0.03)	-0.04 (0.03)
REGQUALITY	0.3*** (0.1)	0.1* (0.1)	0.1 (0.1)
RULELAW	0.3*** (0.1)	0.5*** (0.1)	0.5*** (0.1)
ACCOUNTABILITY	-0.005 (0.05)	-0.01 (0.1)	-0.01 (0.1)
Constant	0.1*** (0.02)	0.2*** (0.01)	
Observations	256	256	256
R2	0.9	0.6	0.5
Adjusted R2	0.9	0.6	0.4
F Statistic	891.9*** (df = 5; 250)	449.3***	40.5*** (df = 5; 235)
Note: *p<0.1; **p<0.05; ***p<0.01			

Source: calculated by authors, based on World Bank Data

The results of the analysis show that the first model is the most significant. As can be seen from Table 2, the control of corruption, the quality of regulation and the rule of law have the greatest impacts on the effectiveness of the government. The same calculations were done for developed and developing countries separately. Developed and developing countries were identified according to World Bank approach. The same sample was used.

The results of the analysis showed that in developed countries, corruption control has the greatest impact on the effectiveness of the government. In these countries, an

effective system of law has already been created, so for the model, the indicator “Rule of Law” is actually a constant. Similarly, the impact of accountability on government effectiveness can be described. Since the accountability system has long been developed and functions effectively, it can be considered constant throughout the study period. It can be concluded that it is important for the governments of developed countries to continue following their democratic traditions, to maintain a high level of accountability, rule of law, and regulatory effectiveness.

In developing countries, the greatest influence on the government effectiveness is exerted by the control of corruption, the effectiveness of regulation, and the rule of law. There is also the influence of political stability (Table 3).

**Table 3.** Results of the Testing the Second Hypothesis (for Developing Countries)

	Dependent variable:		
	GOVERNEFF		
	Pooling	Random	Within
CONTROLCORRUPTION	0.4*** (0.1)	0.2*** (0.1)	0.2*** (0.1)
POLISTAB	-0.01* (0.04)	-0.04 (0.03)	-0.04 (0.03)
REGQUALITY	0.3*** (0.1)	0.1* (0.1)	0.1 (0.1)
RULELAW	0.4*** (0.1)	0.6*** (0.1)	0.6*** (0.1)
ACCOUNTABILITY	-0.05 (0.1)	-0.04 (0.1)	-0.1 (0.1)
Constant	0.1*** (0.03)	0.1** (0.01)	
Observations	208	208	208
R2	0.9	0.6	0.5
Adjusted R2	0.9	0.6	0.4
F Statistic	346.7*** (df = 5; 202)	260.3***	35.3*** (df = 5; 190)
Note: *p<0.1; **p<0.05; ***p<0.01			

Source: calculated by authors, based on World Bank Data

It should be noted that in developing countries the legal system is in a state of transformation. Some countries have achieved significant success in ensuring the rule of law, notably the Czech Republic, and Poland, and some, such as Ukraine, have provided only a formal framework for the rule of law.

For many developing countries, the factor of political stability is important. Political stability ensures the constancy of the political and economic development of the country. This allows society to see more realistic results of the work of the government bureaucracy. For developing countries, an important indicator of government performance is the quality of regulation. The quality of regulation provides positive conditions for economic development, which is a very important fact for developing countries, since they have yet to overcome the gap in economic development with the

developed countries. As can be seen from the Table 4, control of corruption depends on rule of law and accountability.

**Table 4.** Regression Statistic for the Indicator “Control Corruption”

	Dependent variable:
	CONTROLCORRUPTION
	Pooling
RULELAW	1.2*** (0.04)
ACCOUNTABILITY	-0.3*** (0.05)
Constant	-0.03* (0.02)
Observations	256
R2	0.9
Adjusted R2	0.9
F Statistic	1,504.0*** (df = 2; 253)
Note:	*p<0.1; **p<0.05; ***p<0.01

Source: calculated by authors, based on World Bank Data

Therefore, for developing countries in which corruption is one of the obstacles to business development and the emergence of democracy, it is important to ensure that rule of law and government accountability are foundational, guarded, and encouraged by the developed countries.

It should be noted that most countries with low GDP per capita, including Ukraine, Belarus, and Bulgaria, need large amounts of investment for the development of the economy, especially for business infrastructure. Most countries cannot cover the need for investment through domestic resources, so they expect to attract funds from foreign investors. In this regard, the question arises of how difficult it is to attract investments in countries with a high level of corruption, a lack of rule of law, and low effectiveness of regulation. It is obvious that investors will more willingly invest in countries where the effectiveness of the government is higher, and the rights of the investor will be guaranteed due to a low level of corruption and a functioning judicial system. This fact partly explains the fact that some post-socialist countries have achieved greater success in economic development in comparison to those countries where the effectiveness of the government remains low.

### **4.3 Testing the Impact of Informational Technology (E-Governance) Implementations on Government Effectiveness**

The third hypothesis is that government effectiveness, control of corruption, political stability, regulation quality, rule of law and accountability depend on government online service index (GOVONLINESER). Some research states that e-governance helps to reduce corruption, especially in developing countries. When citizens communicate with government officials, the risk of corruption is higher. E-governance

decreases the need for direct communication and, therefore, decreases risk of corruption. The results of the analysis are presented in Table 5.

**Table 5.** Results of the Testing the Third Hypothesis

	Dependent variable:			
	CONTROLCORRUPTION			
	Pooling	Random	Within	Between
REGQUALITY	0.2 (0.1)	0.1 (0.1)	-0.02 (0.1)	0.2 (0.4)
RULELAW	0.9*** (0.1)	0.5*** (0.1)	0.1 (0.1)	0.8* (0.4)
ACCOUNTABILITY	0.2 (0.1)	0.4*** (0.1)	0.4** (0.1)	0.1 (0.4)
GOVONLINESER	0.2 (0.1)	0.05 (0.1)	-0.02 (0.1)	0.6 (0.1)
Constant	-0.4*** (0.02)	-0.3*** (0.01)		
Observations	90	90	90	15
R2	0.9	0.6	0.2	1
Adjusted R2	0.9	0.6	0.1	0.9
F Statistic	333.9*** (df = 5; 250)	152.7***	3.4** (df = 4; 71)	48.3*** (df = 4; 10)
Note: *p<0.1; **p<0.05; ***p<0.01				

Source: calculated by authors, based on World Bank Data

The obtained dependencies are statistically significant, and the determination coefficient shows that the first three models describe the studied dependence well. As can be seen from the results of the calculations, the government online service index does not affect corruption control.

In the next stages of the study, we tested how the government online service index affects accountability, rule of law, regulatory quality, and government effectiveness in general. For these indicators, except for accountability, the government online service index has no affect. The results of calculations on the degree of influence of the government online service index on accountability are given in Table 6.

**Table 6.** Results of the Testing the Impact of Government Online Service Index on Accountability

	Dependent variable:			
	ACCOUNTABILITY			
	Pooling	Random	Within	Between
REGQUALITY	0.3*** (0.1)	0.3*** (0.1)	0.2** (0.1)	0.2 (0.2)
RULELAW	0.6*** (0.1)	0.3*** (0.1)	0.3** (0.1)	0.7** (0.3)
CONTROLCORRUPTION	0.2 (0.1)	0.2*** (0.1)	0.2** (0.1)	0.04 (0.2)
GOVONLINESER	-1.0***	-0.1*	-0.1	-2.1***

	(0.2)	(0.1)	(0.1)	(0.5)
Constant	0.7*** (0.1)	0.3*** (0.1)		
Observations	90	90	90	15
R2	0.9	0.7	0.3	1
Adjusted R2	0.9	0.7	0.2	0.9
F Statistic	231.5*** (df = 4; 85)	203.3***	9.2*** (df = 4; 71)	52.2*** (df = 4; 10)
Note:	*p<0.1; **p<0.05; ***p<0.01			

Source: calculated by authors, based on World Bank Data

As can be seen from the calculations, the impact of the introduction of e-government services on accountability is negative. The result can be explained by two main reasons. First, when a study is conducted over a short period of time, the calculations should be repeated after a certain time, that is, when the government online service index will have at least seven points. The second is the calculations were made without considering time lag, which should be addressed in further research.

Although the third hypothesis has not been confirmed on the investigated period of time, this does not mean that the introduction of e-government will not have a positive effect on the effectiveness of government bureaucracy. However, such an estimate could be made when the indicators are studied for a longer period of time.

## 5 Conclusions

The transformation of the public sector after 1989 was aimed at consolidating the democratic process and accelerating economic development. However, administrative reforms in the countries of Central and Eastern Europe face serious problems in the context of economic liberalization, including insufficient opportunities for modernization and the cultural heritage of the past. Therefore, it is necessary to assess the impact of reform of government bureaucracy by examining government transparency and economic growth.

The results of the empirical analysis show that the effectiveness of the government in the countries of Central and Eastern Europe is one of the key factors of economic development. It is a more significant factor for developing countries than for developed, because developed countries have a high level of government effectiveness. The threat for government effectiveness in developed countries is the level of control of corruption.

Government effectiveness in developing countries is lower according to World Bank data, and it highly depends on the control of corruption, rule of law, and quality of regulation. The economic growth in those countries is also slow. Those countries need to attract external investments. It would be much easier to do so if investors are confident in government effectiveness. This means a low level of corruption, effective rule of law, and effective government regulation.

The results of the empirical research have subsequently confirmed that after the adoption of civil transformation, public administration becomes more effective in



fighting corruption, as well as ensuring economic growth. Fighting corruption is one of the weak spots of developing countries. The empirical results showed that the control of corruption depends on rule of law and government accountability. The introduction of e-government at the time of the evaluation has had no effect on the effectiveness of the government seen in its entirety, and on the control of corruption specifically. Therefore, countries with low government effectiveness should not have great expectations for e-government, but they should work more on the implementation of rule of law and increase quality of regulation.

Consequently, despite delays and difficulties, the transformation of government bureaucracy is vitally important, and democratic countries can truly expect more positive results sooner than countries that are slowly moving along the path of democratization.

This research has several limitations. Firstly, the sample is limited by Eastern and Central European countries. Secondly, the time length for e-governance study is limited to the years 2012-2017, because a government online service index is only available for this period. Thirdly, there is only one indicator of economic development that was tested. The research will be continued in the future to eliminate mentioned limitations.

## References

1. Asgarkhani, M.: "E-Governance in Asia Pacific", Proceedings of the International Conference on Governance in Asia, Hong Kong. (2002).
2. Batrymenko, O.: Trends in the Development of the Bureaucracy in the Conditions of Modern Socio-political life, Bulletin of the Taras Shevchenko National University of Kyiv, Vol. 91/93, p. 188-191. (2009) (in Ukrainian)
3. Bhatnagar, S.: E-government: Lessons from Implementation in Developing Countries. Regional Development Dialogue, 24, 164-174. (2002).
4. Beynon-Davies, P., Williams, M.D.: Evaluating electronic local government in the UK. Journal of Information Technology, 18(2), 137-149. (2003).
5. Chen, Z., Dubinsky, A.J.: A conceptual model of perceived customer value in e-commerce: A preliminary investigation. Psychology and Marketing, 20(4), 323-347. (2003).
6. Criado, J.I., Ramilo, M.C.: E-Government in practice: an analysis of website orientation to citizens in Spanish municipalities. International Journal of Public Sector Management, 18(3), 191-218. (2003).
7. Evans, P., Rauch, J.E.: Bureaucracy and Growth: A Cross-National Analysis of the effects of "Weberian" State Structures on Economic Growth. American Sociological Review 64(5):748-65. (1999).
8. Fafchamps, M., Labonne, J.: Do politicians relatives get better jobs? Evidence from municipal elections. The Journal of Law, Economics, and Organization 33, 2 (2017), 268-300.
9. Fedosov, V., Paientko T.: Ukrainian Government Bureaucracy: Benefits and Costs for the Society. Business and Management Studies. Vol. 3, No. 2, 8--19. (2017).
10. Garson, D.G.: (1999) Information Technology and Computer Applications in Public Administration: Issues and Trends. London: Idea Group Publishing.

11. Goetz, K.H.: Making Sense of Post-Communist Central Administration Modernisation, Europeanisation or Latinisation? *Journal of European Public Policy* 8(6):1032-51. (2001).
12. Groeneveld, S., Tummers, L. G., Bronkhorst, B., Ashikali, T., Van Thiel, S.: Quantitative methods in public administration: Their use and development through time. *International Public Management Journal*, 18 (1), 61–86. (2015).
13. Gronlund, A.: *Electronic Government: Design, Applications and Management*. Hershey, PA: Idea Group Publishing. (2002).
14. Kamarck, E.C. Nye, J.S.: (2002) *Governance.Com: Democracy in the Information Age, Visions of Governance in the 21st Century*. Washington, D.C.: Brookings Institution Press.
15. Kaufmann, D. *Governance matters III*. Policy Research Working Paper No. 2312, World Bank. (2004).
16. Knack, S. Keefer, P.: *Institutions and Economic Performance: Cross Country Test Using Alternative Institutional Measures*, IRIS Working Paper No. 109. University of Maryland. (1994).
17. Lipsky, M.: *Street-level bureaucracy: Dilemmas of the individual in public services*. 30th Anniversary, expanded edition. New York: Russell Sage Foundation. (2010).
18. Mansuri, G. Rao, V.: *Localizing development: Does participation work?* Washington, DC: The World Bank. (2013).
19. Meier, K. J., O’Toole, L. J.: *Bureaucracy in a democratic state: A governance perspective*. Baltimore, MD: Johns Hopkins University Press. (2006).
20. Meier, K. J.: Governance, structure, and democracy: Luther Gulick and the future of public administration. *Public Administration Review*, 70 (Suppl. 1), 284–291. (2010).
21. Monnier F., Thuillier, G. : *Historie de la bureaucratie: veriteset fictions*. Ed. *Economica*, (2010).
22. Nath, A.: *Political Competition and Elite Capture of Local Public Goods*, Working Paper. (2014).
23. O’Toole, L.: *Governing Outputs and Outcomes of Governance Networks*, In E. Sorenson and J. Torfing, eds., *Theories of Democratic Network Governance* (Basingstoke: Palgrave). (2007).
24. Paientko, T.: *Geographic Information Systems: Should They Be Used in Public Finance Reform Development?* Available at: [http://ceur-ws.org/Vol-2104/paper\\_170.pdf](http://ceur-ws.org/Vol-2104/paper_170.pdf) (2018).
25. Rauch, J.E., Evans, P.B.: *Bureaucratic Structures and Bureaucratic Performance in Less Developed Countries* *Journal of Public Economics*. (2000).
26. Ravishankar, N.: *The Cost of Ruling: Anti-Incumbency in Elections*. *Economic and Political Weekly*, Vol. 44, No. 10: 92-98. (2009).
27. Rogger, D.: *The Causes and Consequences of Political Interference in Bureaucratic Decision Making: Evidence from Nigeria*, Working Paper. (2014).
28. Tsapko, O.: *Scientific Theories about the Place of Bureaucracy in Modern Society, Philosophical and methodological problems of law*, Vol.2, pp. 20-24 (2012) (in Ukrainian).
29. Ungureanu, D.M.: *Science and social responsibility: the “bureaucratic wars” from public choice theory*, *European Journal of Science and Theology*, 8 suppl. 1, 235-244. (2012).
30. Yakovenko, H.: *Functions of Modern State Bureaucracy, Theory and practice of public administration*, Vol. 3 (22), 51-58 (2008) (in Ukrainian).

# Cluster Analysis of Countries Inequality due to IT Development

Vitaliy Kobets<sup>1</sup>[0000-0002-4386-4103], Valeria Yatsenko<sup>2</sup>[0000-0002-2925-7470], and Mykhaylo Voynarenko<sup>3</sup>[0000-0002-1301-1492]

<sup>1</sup> Kherson State University, 27, 40 Universitetska st. Kherson, 73003, Ukraine  
vkobets@kse.org.ua

<sup>2</sup> Taras Shevchenko National University of Kyiv, 90-A, Vasulkivska st., Kiev, 03022 Ukraine  
ValeriaYatsenko5@gmail.com

<sup>3</sup> Khmelnytsky National University, 11 Institutaska st., Khmelnytsky, 29016, Ukraine  
voynarenko@ukr.net

**Abstract.** The choice between economic efficiency and social equity has become a key objection in economic development, since in the current economic system, which has become close to the Pareto optimum, the achievement of both of these goals is mutually exclusive. There is only one way to reach both of these goals – the fundamental change of current system of economic relations and getting access to new curves of production capabilities, which may become quite real within development of Industry 4.0 and 6th technological wave. Nevertheless, nobody can predict the social impact of Industry 4.0 on society, which in the context of future technological changes transforms into Society 4.0. The purpose of this paper is to prepare cluster analysis of countries inequality due to IT development using software package. We researched impact of gross capital formation, research and development expenditure to create innovations, intellectual property and high-technology exports on inequality of countries using principal component analysis based on open data 2012-2015. We found 4 main clusters of 45 countries which have convergence and divergence attributes due to IT development. It was also revealed the countries which had inequality due to other reasons which are not connected with IT development.

**Keywords:** cluster analysis, inequality, IT development, Industry 4.0

## 1 Introduction

For many centuries, economic science was developing and changing according to the current challenges. Consequently, the purpose of economic activity was changing as well: from profit maximization during original accumulation of capital to optimization of

resources in the second half of the XX century, to the social welfare improvement within the concept of sustainable development. As a result, the choice between economic efficiency and social equity has become a key objection in economic theory, since in the current economic system, which has become close to the Pareto optimum, the achievement of both of these goals is mutually exclusive. There is only one way to reach both of these goals –the fundamental change of current system of economic relations and getting access to new curves of production capabilities, which may become quite real within development of Industry 4.0 and 6th technological wave. Nevertheless, nobody can predict the social impact of Industry 4.0 on society, which in the context of future technological changes transforms into Society 4.0. [8] and its ability to change the existing distribution of revenues where 8% of the world's population earn half of the world's total income, while the remaining 92% of people are left with the other half [11].

The purpose of this paper is to investigate the impact of information technologies and innovations on social inequality for different countries.

The paper has the following structure. Section 2 is devoted to the complex analysis of inequality and its influence with technological process. Section 3 describes how the level of inequality under the influence of IT within different countries in 2012-2015. The last section is the conclusion, which sums up the results of the research.

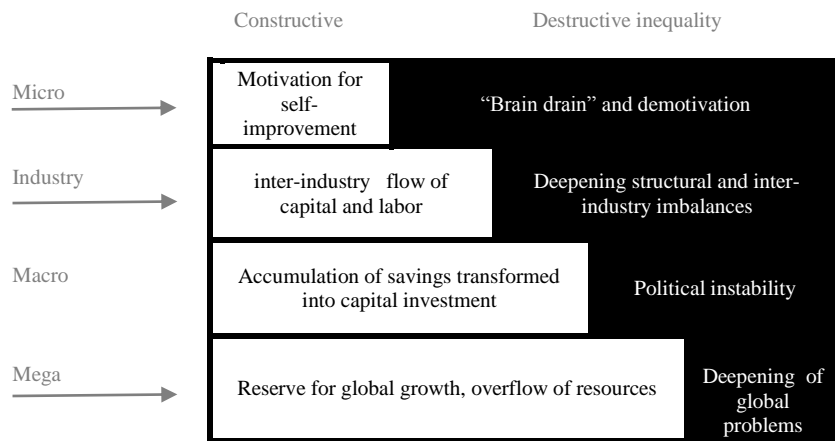
## **2 Related works**

### **2.1 Dialectical Essence of the "Inequality"**

Usually, category of "inequality" is used for analysis of the social equity during the distribution of material and social benefits and is identified as a negative phenomenon that leads to stratification of society, political instability, etc. However, according to the second law of the dialectics "unity and struggle of contradictions", inequality can be analyzed, as well from the positive point of view, transforming into the concept of "constructive inequality" as opposed to "destructive inequality". Moreover, based on complex approach of inequality analysis, we can talk not only about the distribution of the income in society, but also about the distribution of opportunities in it, which can radically change the logic of this topic. To N. Birdsall's opinion, high inequality might be regarded as a lesser evil if it has a positive or neutral impact on growth prospects, or if it is simply a passing phase that successful countries have to endure on route to a prosperous future [1]. Nevertheless, the main question is about the influence of inequality on parties at different levels of economic system, since the income divergence of individuals may have a positive macroeconomic effect (fig. 1).

At micro level the inequality in income distribution in its classical sense has a negative impact, because it causes demotivation of workers, and may even lead to emigration. However, if a society has equal distribution of opportunities a so-called "social elevator",

divergence of incomes can have a constructive effect by increasing the motivation and productivity, gaining new knowledge and skills, self-development, and, consequently, generating higher incomes by workers. As a real example can be society of United States [1], where income gaps are offset by the possibility of implementing the "American Dream", which is a successful example of constructive inequality.



**Fig. 1.** Influence of inequality at different levels of the economic system

At the industry level, the spontaneous unequal allocation of benefits creates a possibility for floating of capital and labor force from less to more productive industries, contributing the economic growth. However, the deliberately inappropriate interdisciplinary distribution of resources can conserve structural imbalances and slow down the country's economic development.

At macro level, in turn, income inequality may be a necessary condition and a consequence of the economic development of a country at certain stages. First of all, according to Keynes's theory of consumption, when income is growing, the marginal propensity to save (MPS) is growing faster than marginal propensity to consume (MPC), which consequently lead to higher marginal propensity to save of rich people rather than poor [2]. What is more, since savings are the main source of investment potential of the country, it explains why it is important to concentrate a certain amount of capital by relatively richer execution of the population in order to meet future development of capital-intensive industries and infrastructure projects, and structural reforms. Secondly, the inequality of income distribution is a logical consequence of the early stages of economic development, which thanks to natural transfer of labor to more productive sectors, decreases later as far as economic growth of a country [3].

On the other hand, unequal distribution of opportunities and incomes can contribute the emigration of highly skilled labor, deepen social instability and lead to a substantial political crisis that will block the possibility of a country's economic development, as it is in countries with totalitarian political regimes.

At global level, inequalities, according to some scientists, for instance N. Birdsall, cannot produce positive effects, since: globalization is commonly held to be inherently disequalising: global markets work better for more productive assets which are disproportionately owned by better-off individuals in richer countries; globalization results in new types of externalities and market failures which poorer persons and weaker nations are ill equipped to handle; globalization creates a need for continuous revision of the rules governing the global economy which is exploited by rich countries for their own narrow interests [1].

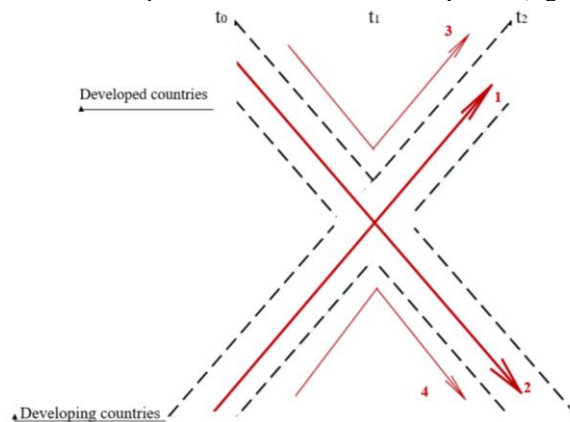
Thus, we can note that the inequality in society is objectively determined and in certain cases, can have a constructive impact on the development of the economic system. This point radically changes the logic of the study from elimination inequalities itself to elimination of destructive inequality. However, the veracity of such findings significantly depends on markets maturity and effectiveness of public institutions, since inequality can create a constructive effect only in well-developed countries where appropriate social infrastructure and high mobility of the population may achieve raise of productivity and efficient resource redistribution. Yet, in developing countries with weak markets, weak governments, and fragile social structures income gaps can only deepen market failures through political instability. This is true because media voter, who has a relatively low level of well-being, will significantly distort political decisions [4] through voting for populist proposals, thus contributing to further ineffective redistribution of income and blocking the development of market mechanisms. In this case, according to many scholars, inequality matters, because developing countries are not developed [5] and this changes the emphasis of research: from managing inequalities to the development of less developed countries. However, it is important to understand which factors can help developing countries to move forward to the class of developed countries and how it will effect on income distribution. One of the variants of radical change in the current distribution of economic benefits in the international economy relates to the Fourth Industrial Revolution often called as Industry 4.0.

## **2.2 The connection of Inequality and Technological Changes**

The second half of the XX century saw a large number of “economic miracles” that had made dramatic changes in the distribution of global economic impact. First of all, we are talking about Japan and the countries of the first wave of newly industrialized economies (NIE's) – “Asian dragons” that received impressive economic development in 50s-60s and 80s respectively. It is no coincidence that the growth of these countries took place

simultaneously when the 4<sup>th</sup> technological wave with its combustion engine was being changed by the 5<sup>th</sup> mainly based on microelectronic components. That is why we can make a logical assumption that technological factor and active technology transfer have played a key role in the growth of labor productivity and the rapid development of industries with high added value in these countries. Similarly, now in the process of moving towards to the Fourth industrial revolution we can expect for a new explosion of “economic miracles” that can alter the ratio of economic power globally. This brings up the question about the possibility of such scenarios implementation and scales of its consequences in the international economy.

Taking into consideration previous industrial revolutions, we can assert that countries with a relatively large amount of capital and production capacity were the first to implement new technologies and inventions and, accordingly, first to receive positive effects from them. That is why it is logical to predict that developed countries with a powerful industrial complex, sufficient amount of capital and developed IT sector will receive greater effects from the new industrial revolution and will continue to dominate the international markets of new high-tech products. However, the development trend of the current economic system is nonlinear which indicates uncertainty of the outputs caused by Industry 4.0 implementation. In our opinion, the future scenario of the international economy development within 6<sup>th</sup> technological wave can be described by X-model and will include four possible scenarios of development (fig. 2).



**Fig. 2.** Probable scenarios of the countries development within Industry 4.0 implementation

*1. Developing countries thanks to new technologies will play a leading role in the international economy*

Of course, as A. Sbardella et al. fairly noted a new sector is not introduced at random, but only when a productive system has developed the required basket of capabilities, and in this way gradually more and more complex sectors are introduced [6]. However,

transnationalization, international technology transfer, and capital inflows are able to eliminate deep technological gaps and time lags between countries and enable developing countries to implement new technologies relatively quickly with low costs. This scenario was used by Southeastern Asia countries. As a result Japan completely changed global GDP ranking by occupying a position in the top 3 countries at nominal GDP [7], while “Asian dragons” took the lead in various international rankings and indices such as Doing Business, Economic Freedom, Innovation Index, etc.

The case for this scenario:

- economic development nowadays is exponential, which makes the consequences of the Fourth Industrial Revolution introduction unpredictable and radically different from previous revolutions;
- economic agents in developing countries, contrary to developed countries, are ready to take risks and are able to adapt much more quickly to new economic conditions;
- developing countries through technology transfer can quickly and with relatively low cost make work Smart factories and Cyber-Physical Systems which will eliminate the time lag with developed countries.

#### *2. Developed countries will lose competitive advantage*

In the majority of developed countries, especially in the EU, we can see increasing risk aversion and lack of the entrepreneurial spirit due to their socio-economic systems are very inertial [8] and people are not able to cope with uncertainty effectively anymore, that is why non-linear trend appears rather than in previous waves of industrial revolutions.

#### *3. Developed countries maintain a leading role in international economy*

Based on great industrial potential, IT field, mature capital markets, and developed institutional system, obviously developed countries are the main promoters of the Fourth Industrial Revolution. Moreover, developed countries will be able to get much more positive effects due to the developed system of supporting or adjacent industries to the Fourth Industrial Revolution. However, this assumption is true only for those countries that have already begun preparations for the introduction of Industry 4.0. For instance, Japan already launched the initiative Society 5.0 - the 5th Science and Technology Basic Plan (Japan's 5th Science and Technology Basic Plan (2016-2020)). Thus, taking into consideration relatively high price for the great majority of resources in developed countries and accordingly, the low price competitiveness of new high-tech goods, the maximization of the effects of the new Industrial Revolution will occur only in the period  $t_2$ .

#### *4. Developing countries do not take advantage of Industry 4.0*

Without sufficient amount of capital and with weak institutional structure, developing countries cannot fully gain all the opportunities and benefits of a new industrial revolution, further exploiting the resource of price competitiveness of their goods and services.



Finally, the implementation of one of these scenarios will depend on the dominance of one of two factors - existing production and technological base, or the ability to adapt quickly and with minimum costs to the new economic environment since the technology progress is faster than the absorption capacity of the society [9].

The simplest way to determine the probability of some scenarios is the Hardy–Weinberg equilibrium according to which there is one abstract feature – countries’ development within Industry 4.0 (table 1). This is determined by two types of alleles – existing industrial and technological complexes, or the ability to take risks and adapt quickly [10] (1). If a significant impact of the IT factor on the level of inequality has been revealed, then it can be predicted how a change in the IT factor will affect the achievement of the level of inequality preferred by society.

$$1=(A+a)^2=A^2+2 Aa +a^2 \tag{1}$$

However, existing studies highlight a deepening of the income divergence between countries because of scientific and technological progress. For instance, Papageorgiou et al. [11] based on IMF research [12] proved that technological progress measured by the share of ICT capital in the total capital stock significantly increase inequality. It is quite obvious because technological development can disproportionately raise the demand for capital labor boosting as a result the premium on skills and then remove many jobs through automation or computerization [11; 13; 14; 15] at least in short-run period. Furthermore, Krueger estimated that employees who directly use computers at work earn a 10 to 15 percent higher wage rate [11].

**Table 1.** Scenario approach to the development of countries within Industry 4.0 according to the Hardy–Weinberg equilibrium

Model Parameters	Existing industrial and technological complexes	Ability to take risks and adapt quickly
Dominant factor-allele <i>A</i>	Scenario 3	Scenario 1
Recessive factor-allele <i>a</i>	Scenario 4	Scenario 2
Existing industrial and technological complexes, %	75	90
Ability to take risks and adapt quickly, %	25	10
Probability of dominant strategy	0.5625	0.81
Probability of recessive strategy	0.0625	0.01
Probability of combination	0.375	0.18

Moreover, within Industry 4.0 this gap will just getting deeper because a great part of low-cost jobs will disappear totally even in developed countries – according to the World Bank estimation, automation will put 57% of the jobs in the 35 countries in OECD at risk, including 47% of US jobs and 77% of the jobs in China [8; 11; 16]. Even more, new

technologies and platform industries as one of the examples hide their inner inequality because of its natural characteristics – high connectivity and unregulated growth [17].

The ambiguity of the influence of Industry 4.0 on income distribution in the international economy is also confirmed at macro level. For instance, France, the United Kingdom, and Spain will meet increasing inequality under the influence of the Industry 4.0 while Germany, vice versa, will see a decrease as a result of technological shifts due to the leadership of the Industry 4.0 initiative [11].

There are two main ways to cope with such inequality: tax system to redistribute the gains of machine production or rebuilding of the actual machinery ownership [17]. A necessary condition of obtaining positive effects of Industry 4.0 is choosing an appropriate strategy for the country as a whole. Adapting a corporate approach, we can outline the following variants of strategic management decisions for countries within technological change (fig. 3).

Experience with Industry 4.0	High (scale from 6 to 10)	IV USA Expansion of competencies	III Optimization of processes and products Germany
	Low (scale from 1 to 5)	I Further operations on the existing way African countries	II Starting with changes China Transition economies
		Low (scale from 1 to 5)	High (scale from 6 to 10)
		Need to adjust business strategy	

**Fig. 3.** Positioning of the country according to its strategy of Industry 4.0 [18]

### 3 Impact of the Industry 4.0 Implementation on Income Inequality

Income inequality depends on many factors, such as land distribution and education, initial levels of inequality, mature of secure property rights and institutional system, social capital, and many others. However, in case of dramatic technological changes caused by Industry 4.0, which will inevitably change economic, managerial and social relations, the greatest attention attracts the connection of technological development of the country and the level of income inequality.

We would like to pose following research question. What impact information technologies and innovations have on social inequality for different countries? One of main index of social inequality is Theil index as a statistic primarily used to measure economic inequality and other economic phenomena.

The Theil T index is defined as

$$T = \frac{1}{N} \cdot \sum_{i=1}^N \left( \frac{x_i}{\bar{x}} \cdot \ln \frac{x_i}{\bar{x}} \right) \quad (2)$$

where  $x_i$  is individual income of  $i$ -th country,  $\bar{x}$  is average income for the country, and  $N$  is the average number of people in the country. If the average incomes of all individuals are equal, then Theil indexes are zero. If the income of the entire population is concentrated in the hands of one individual, then Theil indexes are equal to  $\ln N$ .

To compare Theil indexes (TI) for different countries we will use weighted average of TI using GDP:

$$TI = \frac{GDP_i}{GDP} \cdot \frac{1}{N} \cdot \sum_{i=1}^N \left( \frac{x_i}{\bar{x}} \cdot \ln \frac{x_i}{\bar{x}} \right) \quad (3)$$

where  $GDP_i$  – gross domestic product of country  $i$ ,  $GDP = \sum_{i=1}^n GDP_i$  – world GDP.

Among explanatory variables we can use datasets for 2012-2015 years (after introduction of conception Industry 4.0 in 2011):

- 1) Gross capital formation % of GDP ( $X_1$ ), which can substitute labor resources [19];
- 2) Research and development expenditure (% of GDP) ( $X_2$ ) to create innovations [20];
- 3) Intellectual property, payments ( $X_3$ ) to have competitive advantages for know-how [21];
- 4) High-technology exports (% of manufactured exports) ( $X_4$ ), which have no domestic analogues [22].

Using software package RStudio requires the following libraries and scripts for 45 countries which have been influenced by explanatory variables:

```
library("dplyr") # data analysis
library("psych") # descriptive statistics
library("lmtest") # test for linear models
library("glmnet") # LASSO + ridge
library("ggplot2") # graphs
library("sjPlot") # significance of parameters

ineqc<-read.csv("_2012.txt", sep="\t", header=TRUE, dec=",")
l<-ineqc
l$countryname <- as.character(l$countryname)
glimpse(l) #
l <- select(l, - Y, -id, -countryname) #
describe(l)
ineqc
cor(l)
```

Correlations between explanatory variables are very low:

```
> cor(l)
          X1          X2          X3          X4
X1  1.00000000 -0.2273892 -0.08686789 -0.1143369
X2 -0.22738920  1.0000000  0.33378478  0.2260948
X3 -0.08686789  0.3337848  1.00000000  0.3401378
X4 -0.11433693  0.2260948  0.34013781  1.0000000
```

It means there are no significant correlations between all explained variables.

To investigate how explanatory variables can impact on countries inequality we will use principal methods after preliminary standardization of variables using data set for Theil index analysis [23] (fig. 4):

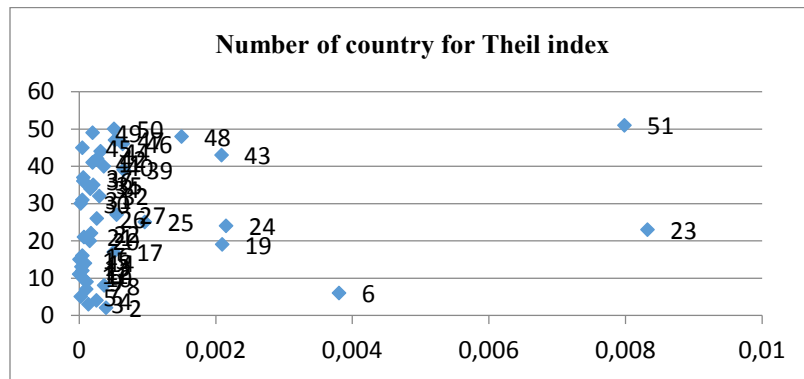


Fig. 4. Country distribution under Theil index (2012)

```
l.pca <- prcomp(l, scale=TRUE)
pcal <- l.pca$x[,1] # extraction of first principal
component
head(pcal)
tail(pcal)
v1 <- l.pca$rotation[,1] # extraction of the weights with
which the variables belong to the first principal component:
summary(l.pca)
biplot(l.pca, xlim=c(-1,1))
          X1          X2          X3          X4
-0.3378705  0.5519592  0.5628580  0.5141746
```

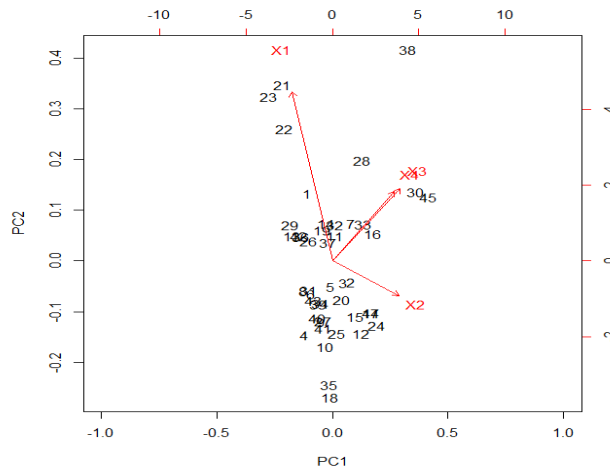
$X_1$  decreases level of inequality. At the same time  $X_2$ ,  $X_3$  and  $X_4$  increase level of inequality. The first two principal components have a sample variance equal to 66,32% of the total sample variance of 4 indicators:

Importance of components:

	PC1	PC2	PC3	PC4
Standard deviation	1.3001	0.9811	0.8633	0.7758
Proportion of Variance	0.4225	0.2407	0.1863	0.1505
Cumulative Proportion	0.4225	<b>0.6632</b>	0.8495	1.0000

### Cluster 2012

The cluster for original data set in 2012 includes following axes: pc1 – horizontal axis, PC<sub>2</sub> – vertical one (fig. 5).



**Fig. 5.** Four cluster of countries with regard to the level of inequality under the influence of IT (2012)

Cluster 1 ( $X_1$ ) for countries # 1, 21, 22, 23 inequality in Hong Kong, Hungary and India is formed due to gross capital formation in GDP.

Cluster 2 ( $X_3$ ,  $X_4$ ) – countries # 28, 30, 45 intellectual property and high-technology exports creates inequality for Latvia, Malaysia and USA.

Cluster 3 ( $X_2$ ) – countries # 5, 15, 20, 24, 32, 47 Research and development expenditure form inequality for these countries.

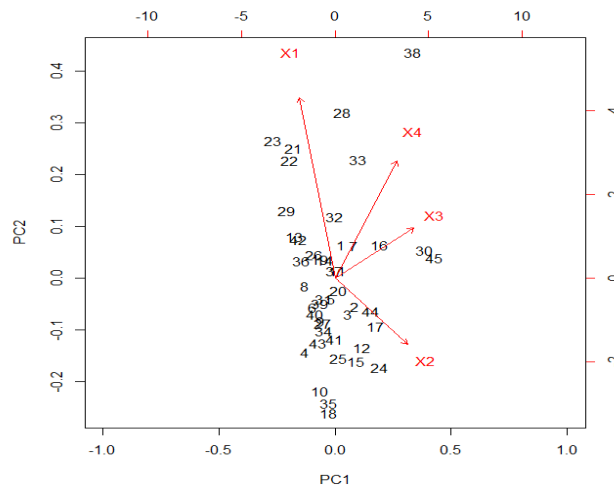
Cluster 4 (0) – other countries. Inequality for these countries (including Ukraine) exists due to other reasons than explanatory variables  $X_1$ - $X_4$ .

### Cluster 2013

Importance of components:

	PC1	PC2	PC3	PC4
Standard deviation	1.2805	1.0300	0.8555	0.7533
Proportion of Variance	0.4099	0.2652	0.1830	0.1419
Cumulative Proportion	0.4099	<b>0.6752</b>	0.8581	1.0000

The clusters for original data set in 2013 is shown in fig. 6.



**Fig. 6.** Five clusters of countries with regard to the level of inequality under the influence of IT (2013)

Cluster 1 ( $X_1$ ) for countries 21, 22, 23 inequality in Hong Kong, Hungary and India is formed due to gross capital formation in GDP (without changes).

Cluster 2 ( $X_1$  and  $X_4$ ) for Latvia (28) and Philippines (33) inequality is induced by gross capital formation (% of GDP) and high-technology exports (new cluster).

Cluster 3 ( $X_3$ ) – 30, 45 intellectual property and High-technology exports creates inequality for Malaysia (30), USA (45) and Estonia (16) (without changes).

Cluster 4 ( $X_2$ ) – combines countries which have strong impact of research and development expenditure 2, 3, 4, 5, 10, 12, 15, 17, 18, 24, 25, 29, 32, 35, 40, 41, 43, 49 (Ukraine).

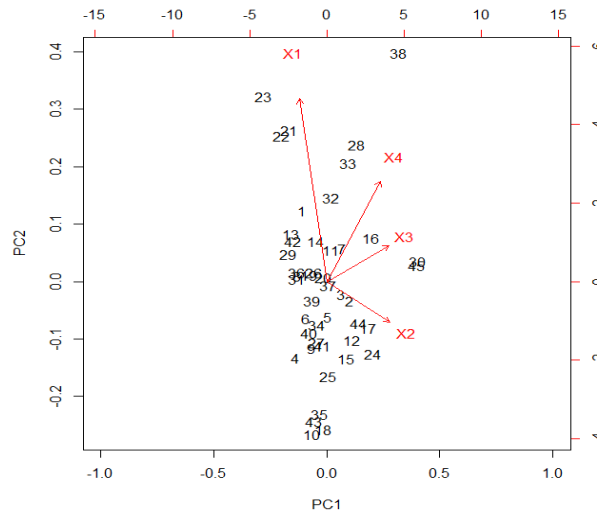
Cluster 5 (0) – 8, 36, 26, 37, 39, 20, 8 etc. Inequality exists due to other reasons than Industry 4.0

### Cluster 2014

Importance of components:

	PC1	PC2	PC3	PC4
Standard deviation	1.2935	1.0229	0.8176	0.7824
Proportion of Variance	0.4183	0.2616	0.1671	0.1530
Cumulative Proportion	0.4183	<b>0.6798</b>	0.8470	1.0000

The clusters for original data set in 2014 is shown in fig. 7.



**Fig. 7.** Two main clusters of countries with regard to the level of inequality under the influence of IT (2014)

There are 2 alternative ways of inequality formation in 2014 and 2015:

Cluster 1 includes countries, which increase  $X_1$ ,  $X_4$  and  $X_3$  (few countries)

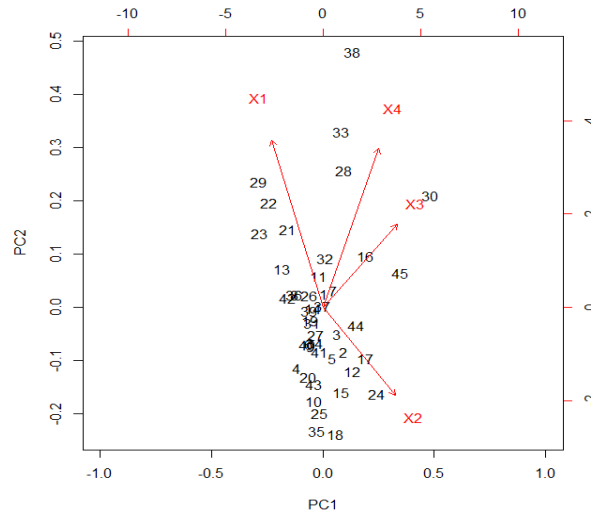
Cluster 2 consist of countries which increase inequality due to  $X_2$  (including Ukraine)

### Cluster 2015

Importance of components:

	PC1	PC2	PC3	PC4
Standard deviation	1.2252	1.0404	0.8599	0.8228
Proportion of Variance	0.3753	0.2706	0.1849	0.1692
Cumulative Proportion	0.3753	<b>0.6459</b>	0.8308	1.0000

The clusters for original data set in 2015 is shown in fig. 8.



**Fig. 8.** Two main clusters of countries with regard to the level of inequality under the influence of IT (2015)

There are 3 alternative ways for 2014 and 2015. Cluster 1 consists of countries  $X_1$  (21, 22, 23, 29). Cluster 2 consists of countries that increase inequality due to  $X_3$  and  $X_4$  (16, 30, 45, 28, 33). Cluster 3 includes countries that increase inequality due to  $X_2$  (including Ukraine). At the same time IT factors and Industry 4.0 are not necessarily deleting jobs, but can act as a transformative agent on the nature of jobs (countries in the center of fig. 8). This fact is confirmed for example by authors [24].

Thus 25% of countries create inequality due to gross capital formation, intellectual property, high-technology exports and 75% of countries form inequality as a result of research and development expenditure (radical innovations gives more welfare and different level of living standards).

## 4 Conclusions

Industry 4.0 creates a new possibility for digitalization, robotics, automation of all business process, creation of modern product and services. It gives competitive advantages to increase export of countries, increasing of the global level of competitiveness but extend the level of frictional and structural unemployment which decrease the level of income for individual and increase the gap of inequality between different segments of inhabitants.



Thus research and development generated more inequality between different countries. Inequality in Ukraine is growing mainly under impact of research and development expenditure during 2012-2015. Intellectual property and high-technology exports changed its impact from same level to different inequality level. Gross capital formation became more significant for other countries than for initial leaders (Hong Kong, Hungary, India). About 44% of all countries had inequality due to other reasons which are not connected with IT development and diffusion of Industry 4.0 which has different speed of expanding for different countries.

## References

1. Birdsall, N.: The World Is Not Flat: Inequality and Injustice in Our Global Economy, WIDER Annual Lecture 9, UNU World Institute for Development Economics Research (2007). [http://cgdev.org.488elwb02.blackmesh.com/doc/commentary/speeches/Birdsall\\_WIDERpaper.pdf](http://cgdev.org.488elwb02.blackmesh.com/doc/commentary/speeches/Birdsall_WIDERpaper.pdf)
2. Kobets, V., Yatsenko, V., Mazur, A., Zubrii, M.: Data analysis of private investment decision making using tools of Robo-advisers in long-run period. In: Proceedings of the 14th International Conference on ICT in Education, Research and Industrial Applications. Integration, Harmonization and Knowledge Transfer, Kyiv, Ukraine, 14–17 May 2018, vol. 2104, pp. 144--159 (2018).
3. Kuznets S. Economic growth and income inequality. *The American economic review* 45(1), 1--28 (1955).
4. Alesina, A., Roderick, D.: Distributive Politics and Economic Growth. *Quarterly Journal of Economics* 109 (2): 465--490 (1994).
5. Banerjee, A., Mokherjee, D., Munshi, K., Ray, D.: Inequality, Control Rights, and Rent Seeking: Sugar Cooperatives in Maharashtra. *Journal of Political Economy* 109 (1): 138-190. (2001).
6. Sbardella, A, Pugliese, E, Pietronero, L.: Economic development and wage inequality: A complex system analysis. *PLoS ONE* 12(9): e0182774. <https://doi.org/10.1371/journal.pone.0182774> (2017).
7. Statistic database. Available at <http://statisticstimes.com/economy/projected-world-gdp-ranking.php>
8. Vacek, J.: On The Road: From Industry 4.0 to Society 4.0. *Trendy v Podnikání*, Vol.7(4), pp.43--49 (2017).
9. Snihovyi O., Kobets V., Ivanov O.: Implementation of Robo-Advisor Services for Different Risk Attitude Investment Decisions Using Machine Learning Techniques. In: Ermolayev V., Suárez-Figueroa M., Yakovyna V., Mayr H., Nikitchenko M., Spivakovsky A. (eds) *Information and Communication Technologies in Education, Research, and Industrial Applications. ICTERI 2018. Communications in Computer and Information Science*, vol 1007, pp 298--321 (2019).
10. Kuzmin, O., Sidorov, Y., Kozik, V.: *Achievements and Problems of Evolutionary Economics: Monograph*. Publishing House of Lviv Polytechnic National University (2011).
11. Kuzmenko, O., Roienko, V.: Nowcasting Income Inequality in the Context of the Fourth Industrial Revolution. *SocioEconomic Challenges*, Vol. 1, p.p. 5--12. Recuperado en septiembre 2017 de: [http://armgpublishing.sumdu.edu.ua/wp-content/uploads/2016/12/files/sec/issue1/SEC\\_1\\_2017\\_Kuzmenko.pdf](http://armgpublishing.sumdu.edu.ua/wp-content/uploads/2016/12/files/sec/issue1/SEC_1_2017_Kuzmenko.pdf) (2017).

12. Papageorgiou, C., Jaumotte, F., Lall, S.: Rising Income Inequality: Technology, or Trade and Financial Globalization? IMF Working Paper, International Monetary Fund. Available at <https://www.imf.org/external/pubs/ft/wp/2008/wp08185.pdf> (2008).
13. Card, D., DiNardo, J. E.: Skill Biased Technological Change and Rising Wage Inequality: Some Problems and Puzzle, NBER Working Paper 8769, National Bureau of Economic Research, Cambridge, Massachusetts. Retrieved from <http://davidcard.berkeley.edu/papers/skill-tech-change.pdf>. (2002).
14. Krueger, A.B.: How Computers have Changed the Wages Structure – evidence from microdata, 1984-1989. *Quarterly Journal of Economics* 108, 33--60 (1993).
15. Kobets, V., Poltoratskiy, M.: Using an evolutionary algorithm to improve investment strategies for industries in an economic system. In: *Proceedings of the 12th International Conference on ICT in Education, Research and Industrial Applications. Integration, Harmonization and Knowledge Transfer*, Kyiv, Ukraine, 21–24 June 2016, Vol. 1614, pp. 485--501 (2016).
16. Frey, C., Osborne, M.: The Future of Employment: How susceptible are jobs to computerisation. Available at <http://www.oxfordmartin.ox.ac.uk/publications/view/1314>(2013).
17. Devlin, S.: (In) Equality in the Digital Society Workshop Summary. New Economics Foundation. Friedrich-Ebert-Stiftung London (2017).
18. Merz, S. L.: *Industrie 4.0 – Vorgehensmodell für die Einführung*, Springer-Verlag Berlin, Heidelberg, Germany (2016).
19. Data set for gross capital formation (% of GDP), <https://data.worldbank.org/indicator/NE.GDI.TOTL.ZS>
20. Data set for research and development expenditure (% of GDP), <https://data.worldbank.org/indicator/GB.XPD.RSDV.GD.ZS>
21. Data set for charges for the use of intellectual property, payments (BoP, current US\$), <https://data.worldbank.org/indicator/BM.GSR.ROYL.CD?view=chart>
22. Data set for high-technology exports (% of manufactured exports), <https://data.worldbank.org/indicator/TX.VAL.TECH.MF.ZS?view=chart>
23. Data set for Theil index analysis, <https://drive.google.com/open?id=1SSb26seUYM2Vj1AjoyUN6jnWG3Sx8zMB>
24. Braccini, A.M., Margherita, E.G.: Exploring Organizational Sustainability of Industry 4.0 under the Triple Bottom Line: The Case of a Manufacturing Company. *Sustainability* 36, 1--17 (2019).

# Simplified Model of Bank Balance Sheet Management

Victor Selyutin<sup>[0000-0002-2209-1009]</sup>

Federal Southern University, I.I. Vorovich Institute of Mathematics, Mechanics, and Computer Science, av. Stachki 220/1, 344090 Rostov-on-Don, Russia  
vvs1812@gmail.com

**Abstract.** The central issue of bank management is obtaining maximum yield while complying with prudential supervision requirements to reliability and good standing. Particular attention should be given to liquidity risks, whose fully-fledged analysis and management require to approach the bank as a dynamic system. The developed mathematical model includes three asset components (loans; bonds and another low risk securities; liquid assets – accounts, reserves, cash) and two liabilities components (equity and borrowed capital – deposits). Main management parameters of the bank's balance sheet that support choosing adequate combination of returns and liquidity risk include turnover times of the loan portfolio and the securities portfolio, loan and deposit rates, the cash reserve ratio. This approach allows to clearly describe the transformation mechanism of core cash flows and formalize various rules of assets and liabilities management. The findings include analytical expressions allowing to research the impact of main constraints on the bank's yield. Computer-aided implementation of this model may be used for numerical simulation studies of balance sheet items and efficiency of different algorithms of asset allocation decision-making.

**Keywords:** Bank, Mathematical Modelling, Simulation Algorithm, Balance Sheet, Liquidity Risk, Profitability.

## 1 Introduction

As elements of the financial system, banks perform a variety of functions, including that of operators maintaining clients' accounts, funds transfers, securities trading, currency exchange etc. However, the main function banks perform as financial intermediaries is transforming the borrowed funds in the loans required by enterprises and customers.

In the context of economic instability, the role of banking risk management becomes of paramount importance. According to GARP (Generally Accepted Risk Principles), the six core categories of banking risks include: *credit risk*, *market risk*, *portfolio concentrated risk*, *liquidity risk*, *operation risk* and *business event risk*.

The banking risks literature pays most of its attention to *credit* risks. A wide range of mathematical models of credit risks that became commercial products (*CreditMetrics<sup>TM</sup>*, *EDFCalc<sup>®</sup>*, *CreditRisk+*, *CreditPortfolioView<sup>TM</sup>*) are in place, but credit risk modelling, prediction, analysis and management still remain in the highlight.

*Market* risk modelling has quite a long history dating back to classic studies of *Markowitz*, (1952, 1959) and *Roy* (1952), and is related with optimizing asset portfolios in risk/return terms, when the most common risk management measures include either portfolio variance, or set risk measures generated by *Lower Partial Moments*,  $LPM_k(\tau)$  in different combinations of  $k$  and  $\tau$ , such as default probability, mean absolute semi deviation, standard semi deviation etc.

*Operation* risks are mostly referred to bank management operations, HR management and information technology processes, while *business event* risks are related with external shocks that can be treated as exogenous scenarios in stress testing practices.

Particular attention should be given to *liquidity* risks, whose fully-fledged analysis and management, especially stress testing, require to approach the bank as a dynamical system. At the same time, the existing approaches to analysis and adequacy of bank liquidity rely mostly on static single-period models. Not so much experience has been gained by the banks in what concerns multi-period models, and the simulation models they underlie.

It's also worth noting that depending on the model focus and the scope of solved tasks, the employed mathematical tools vary considerably. Thus, credit risks are simulated using a variety of probability (stochastic) models; linear and non-linear programming models are used for risk-based asset optimization, multi-period models of assets/liabilities management are discrete-time recurrent (difference) equations. In this paper, we will use continuous-time models based on differential equations.

The purpose of this research consists in: (1) developing quite a simple mathematical model of dynamics of the bank cash flows, including the asset management algorithm for liquidity maintenance; this model is supposed to be used for educational purposes to simulate a variety of scenarios of cash inflow and outflow, including stress testing, and to demonstrate response of the balance sheet to changes of controlled parameters values; (2) analytical study of sensitivity of balance sheet items, and profitability of the bank assets, to controlled, regulatory and external factors.

The paper is organized as follows. After the introduction we present the short review of related works. Section 3 provides the rationale for the model with lumped parameters. Section 4 outlines of balance sheet model creation technique and algorithm of computer simulations. Section 5 provides an analytical representation of the balance sheet structure. Results are discussed in final Section 6.

## 2 Related works

Brief characteristics of some significant studies of the recent years that pay special attention to the dynamic aspect and the role of structural constraints in the course of risk analysis is as follows.

The proposition [1] consists in a dynamic framework which encompasses the main risks in balance sheets of banks in an integrated fashion. The contributions are fourfold: (1) solving a simple one-period model that describes the optimal bank policy under credit risk; (2) estimating the long-term stochastic processes underlying the risk factors

in the balance sheet, taking into account the credit and interest rate cycles; (3) simulating several scenarios for interest rates and charge-offs; and (4) describing the equations that govern the evolution of the balance sheet in the long run. The obtained results enable simulation of bank balance sheets over time given a bank's lending strategy and provides a basis for an optimization model to determine bank asset – liability management strategy endogenously

The work [2] presents a dynamic bank run model for liquidity risk where a financial institution finances its risky assets by a mixture of short- and long-term debt. The financial institution is exposed to insolvency risk at any time until maturity and to illiquidity risk at a finite number of rollover dates. Both insolvency and illiquidity default probabilities in this multiperiod setting are computed using a structural credit risk model approach. Numerical results illustrate the impact of various input parameters on the default probabilities.

The paper [3] analyzes capital requirements in combination with a particular kind of cash reserves, that are invested in the risk-free asset, from now on, compensated reserves. It considers a dynamic framework of banking where competition may induce banks to gamble. In this set up, one can capture the two effects that capital regulation has on risk, the capital-at-risk effect and the franchise value effect. In [4] a discrete-time infinite horizon banking model is considered to examine the interaction between risk weighted capital adequacy and unweighted leverage requirements, their differential impact on bank lending, and equity buffer accumulation in excess of regulatory minima.

The concept [5] consists in developing a dynamic structural model of bank behaviour that provides a microeconomic foundation for bank capital and liquidity structures and analyses the effects of changes in regulatory capital and liquidity requirements as well as their interaction. The stylized bank balance sheet comprises two classes of assets, loans and liquid assets, and four classes of liabilities, deposits, long- and short-term debt, and equity. Decisions on how to adjust these asset and liability classes are taken by risk-neutral managers in a discrete time, infinite horizon setting.

### 3 Substantiation of the Model Aggregation Method

In general, loan dynamics  $x(t, \tau)$  is described with the transport equation [6]

$$\partial x / \partial t + \partial x / \partial \tau = -\varepsilon(\tau)x + u(t, \tau) \quad (1)$$

where  $t$  is the current time,  $\tau$  is the time counted down from the date of loan issue (loan "age"),  $u(t, \tau)$  is the loan issue function,  $\varepsilon(\tau)$  is the rate of loan repayment.

Since loans are usually issued on some standard term  $T_k$  (one day, one week, one month, three months, six months, one year etc.), the equation (1) may be presented as a set of same-type equations  $k=1,2,3,\dots$

$$\partial x_k / \partial t + \partial x_k / \partial \tau = -\varepsilon_k x_k \quad (2)$$

with boundary conditions of  $x_k(t, 0) = u_k(t)$ , each of which has an analytical solution

$$x_k(t, \tau) = u_k(t - \tau) \exp(-\varepsilon_k \tau) \quad (3)$$

Therefore, on the date  $t$ , the total volume of loans issued for the term  $T_k$  are equal to

$$x_k(t) = \int_0^{T_k} x_k(t, \tau) d\tau = \int_0^{T_k} u_k(t - \tau) \exp(-\varepsilon_k \tau) d\tau \quad (4)$$

and their dynamics is described as

$$dx_k / dt = u_k(t) - \varepsilon_k x_k - u_k(t - T_k) \exp(-\varepsilon_k T_k) \quad (5)$$

Then, the loan portfolio dynamics  $x(t)$

$$dx / dt = u(t) - \varepsilon^* x - \sum_k u_k(t - T_k) \exp(-\varepsilon_k T_k) \quad (6)$$

where  $x(t)$  is the loan portfolio volume,  $u(t) = \sum_k u_k(t)$  is the total flow of issued loans,  $\varepsilon^* = (\sum_k \varepsilon_k x_k) / x$  is the weighted average rate of loan repayment

$$x(t) = \sum_k x_k(t) = \sum_k \int_0^{T_k} u_k(t - \tau) \exp(-\varepsilon_k \tau) d\tau \quad (7)$$

Let's present the output flow as

$$u_k(t - T_k) \exp(-\varepsilon_k T_k) = u_k^*(t) + \Delta u_k(t) \quad (8)$$

where  $u_k^*(t)$  is the current average amount of loans issued for  $T_k$  period taking into account their repayment (amortization),  $\Delta u_k(t)$  is the loan deviation from the mean value

$$u_k^*(t) = x_k(t) / T_k \quad (9)$$

It follows from (7) and (9) that the loan portfolio may be presented as

$$x(t) = \sum_k u_k^*(t) T_k \quad (10)$$

Let's define the loan portfolio turnover time  $T_x$  as

$$T_x = x(t) / \sum_k u_k(t - T_k) \exp(-\varepsilon_k T_k) = \sum_k u_k^*(t) T_k / \sum_k [u_k^*(t) + \Delta u_k(t)] \quad (11)$$

While  $\Delta u_k(t)$  values can vary within a wide range, the total deviation  $\sum_k \Delta u_k(t)$  from the average flow is insignificant in the stable bank, i.e.

$$\sum_k \Delta u_k(t) / \sum_k u_k^*(t) \ll 1 \quad (12)$$

Then, to a first approximation, the turnover time  $T_x$  is a weighted average of loan term  $T_k$

$$T_x = \sum_k \Delta u_k^*(t) T_k / \sum_k u_k^*(t) \quad (13)$$

The turnover time  $T_k$  in its meaning is similar to duration  $D_k(t)$ , which is the weighted average maturity of asset or liability, but it is calculated much easier.

In case of constant flow of payments  $u_k^*(t)$  and  $\varepsilon_k=0$ , the duration is obvious to be equal to one half of the turnover time  $D_k(t)= T_k/2$ . In case of payment flow, which is decreasing as it nears the time of repayment, duration is growing. Thus, in case of  $\varepsilon_k T_k=1$ , i.e., when the debt is reducing by the loan maturity by  $e=2.72$  times,  $D_k= 0,582T_k$ .

Finally,

$$dx/dt = u(t) - x/T_x(t) - \varepsilon x \quad (14)$$

where  $u(t)$  is the net flow of loans,  $T_x(t)$  is the loans turnover time,  $\varepsilon$  is the loan amortization (repayment) rate.

Expressions similar to (1)-(14) can be found when describing dynamics of the deposits provided for the term  $y(t,\tau)$  with the only difference being that the negative member  $\varepsilon_k x_k$  meaning loan repayment is replaced with the positive member meaning accrual of deposit interest  $\rho_k y_k$ .

#### 4 The Simplified Aggregated Model of the Bank

To present the logics of operations of the banking institution, let us consider the simplest high-level model of dynamics of the core financial flows, which, nevertheless, describes key aspects of its operations. In the most compact form, which is convenient for a mathematical study, this model is further stated as a system of ordinary differential equations.

When choosing the state vector let's limit ourselves with five aggregated balance sheet items, only four of which are independent in accordance with the principle of equality of assets and liabilities (Table 1). Shareholder's own capital (equity) usually acts as the balancing variable.

The exogenous variable – borrowed and attracted funds (term deposits and demand deposits of individuals and legal entities, clients' account balances, interbank borrowing) serves as the principal source of bank's funds and the starting point of the model.

Dynamics of term deposits  $y_1$  and demand deposits  $y_2$  within the aggregated model is described with same-type equations (1), so for the sake of simplicity, these components of liabilities are combined  $y = y_1+y_2$ , while parameters  $T_y(t)$  and  $\rho_y$  are weighted average

$$dy/dt = v(t) - y/T_y(t) + \rho_y y \quad (15)$$

where  $v(t)$  is a net cash inflow to the deposit accounts,  $T_y(t)$  is the time of liabilities (deposits) turnover,  $\rho_y$  is the interest accrued on deposits. Here it is suggested that the

interest is paid simultaneously with the withdrawal of the deposit, though the model may also use another approach, when the interest is withdrawn as far as it is accrued.

The main issue of liabilities simulation is that  $v(t)$  is a random process. In case of crisis developments, the inflow  $v(t)$  is decreased, and  $T_y(t)$  is reduced as a result of outflow of funds from customer accounts and withdrawal of term deposits (if the latter is provided for under the agreement conditions).

One can state three approaches to prediction and simulation  $v(t)$ .

- *Scenario approach.* A set of possible (suggested) exogenous time-varying functions  $v(t)$  (scenarios) are specified.
- *Statistic approach.* To build  $v(t)$ , one of the methods of forecasting of time series is used.
- *Bayesian approach.* It is based on combining the scenario approach with one or multiple random variables. Depending on the value taken by this random variable, different scenarios of cash inflow and outflow takes place in the certain time interval.

**Table 1.** Stylized Aggregated Balance Sheet of a Commercial Bank, %.

Assets		Liabilities	
Loans, x	60	Equity, c	10
Bonds and other investment securities, b	15	Debt (term and demand deposits, customer accounts and borrowing), y	90
Correspondent accounts, reserves, cash, s	25		
Total assets, A	100	Total liabilities, L	100

The bank's loan portfolio is generated with the attracted (borrowed) funds and loans dynamics describes according to (14).

Usually, when a loan is approved, a deposit account (loan facility) is opened at the same time on the liabilities side, with the borrower withdrawing funds in installments as required from this account, but for the sake of simplicity only the resultant flows are taken into account in the model.

Borrowing demand  $g(t)$  can either exceed the funds at the bank's disposal  $h(t)$ , or be insufficient. That is why

$$u(t) = \min\{g(t), h(t)\} \quad (16)$$

where  $g(t)$  is the lending demand,  $h(t)$  is the bank's funds planned to be allocated as loans.

Approaches to simulation of the lending demand  $g(t)$  are similar to that described above for deposit inflow simulation  $v(t)$ .

Pursuant to the banking risk management policy, only part  $\gamma_x < 1$  of the available funds is allocated for lending



$$h(t) = \gamma_x(t)q(t) \quad (17)$$

where  $q(t)$  is estimated available funds of the bank (inflow less outflow of funds).

Other bank funds are spent to purchase other earning assets, or can be allocated to increase funds in the correspondent accounts and as cash  $s(t)$  thus used as the reserves aimed to mitigate liquidity risks.

Most part of available funds of the bank, including non-demanded funds intended for lending  $\max\{0, h(t)-g(t)\}$  is placed by the bank in the portfolio assets – investment securities, mostly in the bonds, and traded risk assets (stock). At the same time, available securities are paid off or sold. This mechanism can be described as follows

$$db/dt = w(t) + \max\{0, h(t) - g(t)\} - b/T_b(t) \quad (18)$$

where  $b(t)$  is investment in securities,  $w(t)$  is bank's funds planned to be used for purchasing portfolio assets

$$w(t) = \gamma_b(t)q(t) \quad (21)$$

where  $\gamma_b$  is a part of the funds spent on purchasing the securities,  $T_b(t)$  is the turnover time of the securities portfolio.

The key issue of asset management is the algorithm of allocating the bank's funds that, in case of reasonable management, is supposed to depend on the estimated net inflow  $q(t)$ .

This algorithm may be presented as follows. The available investment resources of the bank  $q(t)$  are calculated as the resultant between the inflow (released funds, interest income, deposit growth, redemption of securities) and output flow (growth of reserves, interest expenses, bad loans, operating and other expenses)

$$q(t) = dy/dt - dr/dt + (1 - \xi(t))x/T_x(t) + b/T_b(t) + \varepsilon x + \rho_x x + \rho_b b - \rho_y y - z(t) \quad (20)$$

where  $\rho_x$ ,  $\rho_y$ ,  $\rho_b$  are interest rates, of loans, deposits and securities, respectively,  $r(t)$  is the reserve,  $z(t)$  is the planned operating expenses and other bank payments,  $0 < \xi(t) \leq 1$  is a random process that characterizes bank loss from the bad loans.

Let's provide explanations on certain equation (20) elements.

The principal part of the funds attracted by the bank must be secured with required reserves. In Russia, the required reserves are withdrawn from the banks, placed in non-interest bearing account in the Bank of Russia and can be used to cover the liquidity shortage, only if the set of conditions is met (averaging mechanism). Besides, the bank must establish excess reserves for possible bad loans and as security of current payments. Excess reserves represent any vault cash that banks hold that is in excess of the required reserves amount. Banks typically have a low incentive to maintain excess reserves because cash earns the rate of return of zero.

Primary reserves, as combined with the government bonds (secondary reserves), create the required liquidity cushion that ensures bank stability against adverse changes of the external conditions.

Further, as a separate component, we'll single out the reserves available to support liquidity as percent of the attracted funds, with this percent (above the required reserves) may be regulated by the bank itself

$$r = ay \quad (21)$$

where  $a$  is the cash reserve ratio.

Taking into account the bank may modify the reserve percentage in a flexible manner

$$dr/dt = ady/dt + yda/dt \quad (22)$$

Formula (20) allows to design the criterion of and assess solvency of the bank. Reduced resources  $q(t)$  alert solvency reduction. This can occur, when the deposit outflow starts exceeding their inflow, i.e.  $dy/dt$  becomes negative, the amount of credit default rate  $\xi$  grows and operating expenses  $z(t)$  increase. If  $q(t)$  becomes negative, it means that the bank starts shifting to reduced liquidity, which can finally lead to insolvency and bankruptcy, when the equity becomes negative. In this way equation (20), taken together with (14) and (22), returns the necessary condition (lower limit) of the financial stability and we'll define the financial stability headroom of the bank by the ratio  $\chi$  that may be used as the stability indicator (criterion)

$$\chi(t) = [(1 - \xi(t))x/T_x(t) + b/T_b(t) + \varepsilon x + \rho_x x + \rho_b b] / [z(t) + \rho_v y - (1 - a)dy/dt] \quad (23)$$

As an expert evaluation, we can offer the following scale:  $1 < \chi < 1,5$  – low stability,  $1,5 < \chi < 3$  – medium stability,  $\chi > 3$  – high stability. Apparently, this parameter is fluctuating throughout the bank operations going down during economic recession featuring reduced lending demand and outflow of funds from depositors' account.

To make current payments, the bank needs available cash in the correspondent accounts and in its cash office. These most liquid components of the assets (primary reserves), including reserves for credit losses, are united in variable  $s(t)$ .

As shown above, under pressure, in case of economic shocks or the bank's high-risk lending policy, the value  $q(t)$  may turn out to be negative thus resulting in termination of loan business, suspension of acquiring other assets and reduction of  $s(t)$ . When the bank's financial situation improves, including as a result of state support measures, resolution and capitalization increase, the flow of resources reverses sign and the liquidity adequacy  $s(t)$  must be restored.

With this taken into account, both previously introduced variables – lending cash flows  $h(t)$  and portfolio investment cash flows  $w(t)$  should be adjusted as follows

$$h(t) = \gamma_x(t) \max\{0; \text{sgn}(0, s - r)\} \max\{0, q(t)\} \quad (24)$$

$$w(t) = \gamma_b(t) \max\{0; \text{sgn}(0, s - r)\} \max\{0, q(t)\} \quad (25)$$

and in the cash dynamics equation  $s(t)$  it is necessary to provide possible switching between the modes of expenditure and replacement

$$ds/dt = \text{sgn}(0, r - s) \max[0, q(t)] + \min[0, q(t)] + dr/dt \quad (26)$$

As mentioned above, the bank's equity is a balancing variable, i.e.  $c=x+s+b-y$  and

$$dc/dt = \rho_x x + \rho_b b - \rho_y y - z(t) - \xi(t)x/T_x(t) + \min[0, q(t)] \quad (27)$$

Bank's equity grows due to profit (less the income tax and dividends paid to the shareholders). For the sake of simplicity, taxes are not accounted in this model. The dividends are also considered not to be distributed, and all profit is allocated to increase the equity value.

The algorithm of scenario simulations (after replacing derivatives with finite differences) has the form:

1. Exogenous functions (scenarios) setting  $v(t)$ ,  $T_y(t)$ ,  $g(t)$ ,  $\xi(t)$
2. Setting constant coefficients  $\varepsilon$ ,  $\rho_x$ ,  $\rho_b$ ,  $\rho_y$ ,
3. Setting the calculation step  $\Delta t$
4. Setting initial values of the balance sheet state variables  $c(t)$ ,  $y(t)$ ,  $x(t)$ ,  $s(t)$ ,  $b(t)$
5. Setting initial values of the control variables  $\gamma_x(t)$ ,  $\gamma_b(t)$ ,  $a(t)$ ,  $T_x(t)$ ,  $\rho_a(t)$
6. A new value of the deposits  $y(t+\Delta t)$ , Eq. (15)
7. A new value of the reserves  $r(t+\Delta t)$ , Eq. (22)
8. Operating expenses  $z=\rho_a(t)A$
9. Available investment resources  $q(t)$ , Eq. (20)
10. A new value of the cash and other liquid assets  $s(t+\Delta t)$ , Eq. (26)
11. The lending planned  $h(t)$ , Eq. (24)
12. The planned volume of securities purchase  $w(t)$ , Eq. (25)
13. Issued loans  $u(t)$ , Eq. (16)
14. A new value of the loan portfolio  $x(t+\Delta t)$ , Eq. (14)
15. A new value of the securities portfolio  $b(t+\Delta t)$ , Eq. (18)
16. A new value of the own capital  $c(t+\Delta t)$ , Eq. (27)
17. Stability indicator  $\chi(t)$  Eq. (23)
18. Return to step 4 with  $t = t+\Delta t$

The capital adequacy ratio is used as the main structural constraint. In this model, the constraint takes on the form as follows

$$c(t)/[(1-f)A] = c(t)/\{(1-f)\{c(t) + y(t)\}\} \geq \theta \quad (28)$$

where  $f$  is the share of the risk-free assets,  $\theta$  is the capital adequacy ratio ( $\theta=0.08$  according to the recommendations of the Basel Committee on Banking Supervision,  $\theta=0.1$  for Russian banks).

Therefore

$$c(t) \geq \{(1-f)\theta/[1-(1-f)\theta]\}y(t) \quad (29)$$

Further,  $k$  ratio is more convenient to use as the adequacy ratio

$$k \geq (1-f)\theta/[1-(1-f)\theta] \quad (28)$$

For example,  $f=0.3$ ,  $\theta=0.1$ , then  $k= 0.075$ .

The built model describes dynamics of the main variables of the bank's condition, allows to simulate mechanisms of management and transformation of cash flows and study sensitivity of the balance sheet items and bank profit to the management efforts and external factors, including stress. Thus, it can be considered as a backbone for the theoretical and analytical research. At the same time, aggregating balance sheet items, use of the integral parameters of turnover of assets and liabilities, and the assumption of the continuous smooth character of the used functions prevent from showing some important aspects of the bank's operations. The next step in enhancing adequate description of the bank's operations is using the distributed parameter models [6].

## 5 Structural Constraint Impact on the Bank Performance

Just like any other financial organization attracting funds of people and companies, every bank acts in the context of tight restrictions imposed by the external regulator (in Russia it is the Bank of Russia, in the USA it is the Federal Reserve System), and internal rules. These restrictions are aimed to maximize mitigation of various banking risks, but at the same time they considerably affect the structure and performance of assets.

Suppose that the bank is stable for some period of time, i.e., its amount and structure of assets and liabilities remain unchanged, while profit is fully distributed and its equity does not grow. In this case, one can analytically study impact of different parameters on bank's financial performance, provided the restrictions imposed on the balance sheet structure by the supervisory body are met.

Then the derivatives and several terms in equations (14)-(15), (18), (26)-(27) are set to zero, and one can completely define the balance sheet components via the model ratios.

The borrowed capital is determined by the product of the cash inflow rate by the modified turnover time  $T_y^*$

$$y^* = v/(1/T_y - \rho_y) = vT_y^* \quad (31)$$

and the equity, pursuant to the constraint (18), must be at least

$$c^* = ky^* \quad (32)$$

where  $k=(1-f)\theta/[1-(1-f)\theta]$ .

In the steady mode, pursuant to (29), non-working assets are minimum and equal to reserves

$$s^* = r^* = ay^* \quad (33)$$

Investment in low-income but reliable (low-risk) assets such as government bonds are aimed to ensure financial stability of the bank and mitigate risks. The amount of these investments must correlate with the bank's equity.

Then this component of the assets can be determined as

$$b^* = nc^* \quad (34)$$

Further, we find the loans value from the balance condition,

$$x^* = c^* + y^* - s^* - b^* \quad (35)$$

As a result, the bank's balance-sheet may be presented analytically:

**Table 2.** Analytical Representation of Balance Sheet

Assets $A=(I+k)vT_y^*$	Liabilities $L=(I+k)vT_y^*$
Loans $x^* = [1+k(1-n)-a]vT_y^*$	Equity $c^* = kvT_y^*$
Bonds and other investment securities $b^* = nk vT_y^*$	Debt (term and demand deposits, customer accounts and borrowing)
Liquid assets (reserves, correspondent account, cash) $s^* = avT_y^*$	$y^* = vT_y^*$

Interest income (margin) of the bank  $m$  taking into account the estimated loan loss ratio  $E\xi$  is calculated as

$$m = \rho_x^{\wedge} x^* + \rho_b b^* - \rho_y y^* = \{[1+k(1-n)-a]\rho_x^{\wedge} + \rho_b nk - \rho_y\} y^* \quad (36)$$

where  $\rho_x^{\wedge} = \rho_x - (E\xi)/T_x$ .

Operation expenses  $z$  may be interpreted as some imputed rate  $\rho_a$  of the bank asset servicing  $z=\rho_a A$ , then the pre-tax profit  $p$  amounts to

$$p = m - z = \{[1+k(1-n)-a]\rho_x^{\wedge} + \rho_b nk - \rho_y - \rho_a(1+k)\} y^* \quad (37)$$

Return on assets

$$ROA = p/A = \{[1+k(1-n)-a]\rho_x^{\wedge} + \rho_b nk - \rho_y - \rho_a(1+k)\}/(1+k) \quad (38)$$

Return on equity

$$ROE = p/c^* = ROA(1+k)/k \quad (39)$$

## 6 Conclusion

The aggregated model of the bank as a dynamic system with lumped parameters allows to clearly show the transformation mechanism of core cash flows and formalize various rules of assets and liabilities management. Computer-aided implementation of this model may be used for computational studies of efficiency of different asset management algorithms.

Main controlled parameters of the bank's balance sheet that support choosing adequate combination of yield and liquidity risk include:  $T_x$  – the loan portfolio turnover time,  $T_b$  – the securities portfolio turnover time,  $\rho_x$  – the loan rate,  $\rho_y$  – the deposit rate,  $a$  – the cash reserve ratio.

In the near-stable situation it's not difficult to derive simple analytical expressions allowing to research the impact of these parameters on the bank's yield and liquidity risks. Thus, one can use formulae (25)-(26) to study impact of the control parameters, including a variety of ratios, on the yield, and correlate it with the loan portfolio risks denoted by  $E\xi$  value in this model. The liquidity risk depends on the assets/liabilities turnover time ratio ( $T_x$  and  $T_y$ ). Since  $T_y$  value is not used in expressions (25)-(26), then the ratio  $T_x/T_y$  is an independent parameter that can be used when analyzing the bank's standing in risk/return terms. Let us note that the loan and deposit interest rates affect the respective cash flows  $v(t)$  and  $g(t)$  and must be taken into account when simulating these random processes.

It is seen from (25)-(26) that  $k$  equity ratio to the amount of attracted and borrowed funds significantly impacts the return on equity, but barely affects the return on assets that depends mostly on their structure and interest margin.

The suggested model can be easily extended through drilling-down to the financing sources (demand/term/savings deposit etc.) and asset allocation methods. To dramatically enhance the model adequacy, it is necessary to take into account the time structure of loans and term deposits [6].

*The research has been completed with financial support of the Ministry of Science and Higher Education of the Russian Federation in the project: "Fundamental and Applied Tasks of the Mathematical Modelling" No. 1.5169.2017/8.9*

## References

1. Birge J.R., Judice P.: Long-term Bank Balance Sheet Management: Estimation and Simulation of Risk-factors. *Journal of Banking & Finance* 37(12), 4711–4720 (2013).
2. Liang G., Lütkebohmert E., Xiao Y.: A Multiperiod Bank Run Model for Liquidity Risk. *Review of Finance*. 18(2), 803–842 (2014).
3. Hasman A., Samartin M.: Capital and Liquidity in a Dynamic Model of Banking. *Economic Modelling* 64(8), 172–177 (2017).
4. Mankart J. Michaelides A. Pagratis S.: Bank Capital Buffers in a Dynamic Model. *Bundesbank Discussion Paper No 51*, 38p. (2018).
5. Behn M., Daminato C., Salleo C.: A Dynamic Model of Bank Behaviour under Multiple Regulatory Constraints. *ECB Working Paper Series No 2233*, 62p. (2019).
6. Selyutin V.V., Kharuzhnaya M.A.: Mathematical Modelling of a Bank as a Dynamical System. *The Southern Scientific Centre of the Russian Academy of Sciences Vestnik* 11(3), 3–10 (2015) (In Russian).

# Entropy Analysis of Crisis Phenomena for DJIA Index

Vladimir Soloviev<sup>1</sup>, Andrii Bielinskyi<sup>1</sup>, Viktoria Solovieva<sup>2</sup>

<sup>1</sup>Kryvyi Rih State Pedagogical University, 54, Gagarina Ave., Kryvyi Rih, 50086, Ukraine

<sup>2</sup>Kryvyi Rih Economic Institute of Kyiv National Economic University named after Vadym Hetman, 16, Medychna St., Kryvyi Rih, 50000, Ukraine

{vnsoloviev2016, krivogame, vikasolovieva2027}@gmail.com

**Abstract.** The Dow Jones Industrial Average (DJIA) index for the 125-year-old (since 1896) history has experienced many crises of different nature and, reflecting the dynamics of the world stock market, is an ideal model object for the study of quantitative indicators and precursors of crisis phenomena. In this paper, the classification and periodization of crisis events for the DJIA index have been carried out; crashes and critical events have been highlighted. Based on the modern paradigm of the theory of complexity, a spectrum of entropy indicators and precursors of crisis phenomena have been proposed. The entropy of a complex system is not only a measure of uncertainty (like Shannon's entropy) but also a measure of complexity (like the permutation and Tsallis entropy). The complexity of the system in a crisis changes significantly. This fact can be used as an indicator, and in the case of a proactive change as a precursor of a crisis. Complex systems also have the property of scale invariance, which can be taken into account by calculating the Multiscale entropy. The calculations were carried out within the framework of the sliding window algorithm with the subsequent comparison of the entropy measures of complexity with the dynamics of the DJIA index itself. It is shown that Shannon's entropy is an indicator, and the permutation and Tsallis entropy are the precursors of crisis phenomena to the same extent for both crashes and critical events.

**Keywords:** stock market, Dow Jones Industrial Average index, complex systems, measures of complexity, crash, critical event, permutation entropy, Shannon entropy, Tsallis entropy, multiscale entropy, indicators and precursors.

## 1 Introduction

For the last few decades, the behavior of the global financial system has attracted considerable attention. Wild fluctuations in stock prices lead to sudden trend switches in a number of stocks and continue to have a huge impact on the world economy causing the instability in it with regard to normal and natural disturbances [1]. Stock market prediction is a classic topic in both financial circles and academia. Extreme stock market fluctuations, e.g., the global stock market turmoils in September 2008, February 2018 damage financial markets and the global economy [2]. Thus we need a more effective way of predicting market fluctuations. Among the many predictive quantitative methods and models, Stanley et al. [3] distinguish such as autoregressive

integrated moving average (ARIMA) models, artificial neural networks, support vector machine, and neuro-fuzzy based systems. Recent developments in artificial intelligence and the use of artificial neural networks have increased our success in nonlinear approximation. Previous studies indicate that “deep learning” (DL) solves nonlinear problems more efficiently than traditional methods [4, 5]. Irrespective of the level of complication or the presence of linear and nonlinear big data financial market factors, DL can extract abstract features and identify hidden relationships in financial markets without making econometric assumptions [5]. Traditional financial economic methods and other quantitative techniques cannot do this. Of particular interest are the combined models that include the best aspects of both classical econometric models and modern DL and complex systems models [6].

As for the models and mechanisms of stock market crashes, first of all, it should be noted the works of D. Sornette, which include both a historical overview of the causes of stock crashes [1, 7], the Log-Periodic Power Law Singularity model of financial bubbles [1, 8] and agent-based model [9].

It should be specially noted that we are setting ourselves the task of predicting neither future index values, nor possible trends. Our task is to highlight among the various manifestations of crisis phenomena such patterns that foreshadow in advance noticeable drops in the index value. This allows you to construct a precursor of the approaching crisis.

The doctrine of the unity of the scientific method states that for the study of events in socio-economic systems, the same methods and criteria as those used in the study of natural phenomena are applicable. A similar idea has attracted considerable attention from the community of different branches of science in recent years [10, 11].

Complex systems are systems consisting of a plurality of interacting agents possessing the ability to generate new qualities at the level of macroscopic collective behavior, the manifestation of which is the spontaneous formation of noticeable temporal, spatial, or functional structures [12]. As simulation processes, the application of quantitative methods involves measurement procedures, where importance to complexity measures has been given. I. Prigogine notes that the concepts of simplicity and complexity are relativized in the pluralism of the descriptions of languages, which also determines the plurality of approaches to the quantitative description of the phenomenon of complexity [13]. Therefore, we will continue to study Prigogine's manifestations of the system complexity, using the current methods of quantitative analysis to determine the appropriate measures of complexity.

The financial market is a kind of complex systems with all kind of interactions [14]. Apart from many properties that they interact with other natural complex systems, they have a unique property – their building elements which called investors. In fact, they represent examples of complexity in action because many factors on financial markets and their evolution are dictated by the decision of crowds. Therefore, the financial markets have exceptionally strong ability to self-organize and their characteristics as nonlinearity and uncertainty remains a huge challenge.

The key idea behind our research is that the complexity of the system must change before crisis periods. This should signal the corresponding degree of complexity if they are able to quantify certain patterns of a complex system. A significant ad-



vantage of these measures is that they can be compared with the corresponding time series for monitoring and detecting critical changes of it. This opportunity allows us to use these quantitative measures of complexity in the diagnosis process and prediction of future changes.

The paper is structured as it follows. In Section 2 we describe how many articles and research papers were devoted to the topic of our research. Section 3 presents how we classified our data. Sections 4 and 5 demonstrate methods and results for Permutation, Shannon and Tsallis entropies. The market was analyzed in more detail using Multiscale entropy in Section 6. And finally, on the basis of the conducted research, we draw conclusions in Section 7.

## 2 Review of Previous Studies

Today Dow Jones Industrial Average index (DJIA) is most quoted financial barometer in the world and has become synonymous with the financial market in general. The *Industrial* portion of the name DJIA is largely historical, as many of the modern 30 components have little or nothing to do with traditional heavy industry. Since April 2, 2019, the DJIA includes 30 companies of the American stock market belonging to different sectors of the economy: industrial - 7 (23%), financial - 5 (17%), IT & Telecommunication – 6 (20%), Managed health care & Pharmaceuticals – 4 (13%), Retail, Food, Apparel and other – 8 (27%). In addition, the DJIA index has high pair-correlation coefficients with the most well-known country stock indexes. Due to these reasons, including to itself significant variety of stocks and having a confidence form many people, its dynamics plays an important role in the world economy.

There are a lot of articles and research papers that have been devoted to the DJIA index and its internal dynamics. For example, Charles with Darné [15] determined the events that caused large shocks volatility of the DJIA index over the period from 1928-2013, using a new semi-parametric test based on conditional heteroscedasticity models. They found that these large shocks can be associated with particular events (financial crashes, elections, wars, monetary policies, etc.) They showed that some shocks are not identified as extraordinary movements by the investors due to their occurring during high volatility episodes, especially the 1929-1934, 1937-1938 and 2007-2011 periods.

Also, there are different articles in which authors using entropy principles to detect aggregate fears and major crashes. Gençay and Gradojevic [16] developed a dynamic framework to identify fluctuations through the skewness premium of European options. Their methodology is based on measuring the distribution of a skewness premium through a  $q$ -Gaussian density and a maximum entropy principle. Their findings indicate that the October 19th, 1987 crash was predictable from the study of the skewness premium of deepest out-of-the-money options about two months prior to the crash. H. Danylchuk et al. [17] examined the entropy analysis of regional stock markets. Their paper proposed and empirically demonstrated the effectiveness of using such entropy as Sample entropy, Wavelet and Tsallis entropy as a measure of uncertainty and instability which dynamics can be used such as crisis prediction indicators. Authors of another paper [18] investigated the relationship between the information

entropy of the distribution of intraday returns of intraday and daily measures of market risk. Using data on the EUR/JPY exchange rate, they found a negative relationship between entropy and intraday Value-at-Risk, and also between entropy and intraday Expected Shortfall. This relationship is then used to forecast daily Value-at-Risk, using the entropy of the distribution of intraday returns as a predictor. The research paper of Jun Lim [19] aims to study the efficiency of Permutation entropy in financial time series prediction and primarily focuses on the proposal, implementation and performance evaluation of a novel hash function to optimize the hashing of a large sequence of permutations based on a given financial data series.

In addition to scientific papers on such types of entropy, there are many works on Multiscale types of entropies. R. Gu in his research [20] introduced a new concept of singular value decomposition Multiscale entropy and studied its predictive power on the DJIA index. It was found that from the perspective of linearity, useful information and noise do not have the predictive power on the DJIA index. However, from the perspective of nonlinearity, the useful information has the predictive power on the index in the long-term (at least one year) period, and noise only has the predictive power on the index in the short-term (about one month) period. This means that both useful information and noise have predictive power on stock index, but their capacity of predicting (predictive term) is different, and these predictive powers are presented through nonlinear mechanism rather than the simple linear mechanism. Wang et al. [21] characterize market efficiency in foreign exchange markets by using the Multiscale approximate entropy to assess their randomness. They split 17 daily foreign markets rates from 1984 to 2011 into their periods by two global events: Southeast Asia currency crisis and American sub-prime crisis. The empirical results indicate that the developed markets are more efficient than emerging and that the financial crisis promotes the market efficiency in foreign exchange markets significantly, especially in emerging markets, like China, Hong Kong, Korea, and African market. Pawel Fiedor in cooperation with other researchers [22] extended some of their previous ideas and articles by using the Multiscale entropy analysis framework to enhance their understanding of the predictability of price formation process at various time scales. For their purpose, they estimated Shannon's entropy rate and also used the Maximum Entropy Production Principle as a more constructive framework. Their results indicate that price formation processes for stocks on Warsaw's market are significantly inefficient at very small scales, but these inefficiencies dissipate quickly and are relatively small at time scales over 5 price changes. Further, they showed that the predictability of stock price changes follows a fat-tailed distribution, and thus there exist some predictable price formation processes for some stocks. Strikingly, the Multiscale entropy analysis presented in their study shows that price formation processes exhibit a completely opposite information-theoretic characteristic to white noise, calling into question methods in finance based on Brownian motion or Lévy processes.

This briefly described list of studies shows that the researching of the dynamics of stock markets, the prevention of crisis phenomena on them and the creation of new methods and instruments for these purposes are relevant.

In our previous research papers, we used measures of complexity to prevent crisis states on the cryptocurrency market [23, 24]. The spectrum of entropy measures for the stock market, on the example of the DJIA index, is used in this paper.

### 3 Classification of Data

Financial indices are the main indicators of the work of the stock markets. The DJIA index is the most well-known “blue-chips” stock index. For understanding of the falls that occurred on it, our classification and constructing our indicators, we divided its time series into two parts during the periods from 2 January 1920 to 3 January 1983 and from 4 January 1983 to 18 March 2019 of flexible daily values of the DJIA index.

During the research, crises were separated into crashes and critical events, and it was established that:

- Crashes are short, time-localized drops, with the strong losing of price each day.
- Critical events are those falls that, during their existence, have not had such serious changes in price as crashes.

Obviously, during DJIA index existence, many crashes and critical events shook it. Relying on historical data and normalized returns, where returns are calculated as  $g(t) = \ln X(t + \Delta t) - \ln X(t) \cong [X(t + \Delta t) - X(t)] / X(t)$ , we emphasize that almost 20 crashes and critical events took place, whose falling we identify and predict by our indicators. More detail information is presented on the Sheet below.

**Table 1.** List of DJIA Major Historical Corrections since 1929.

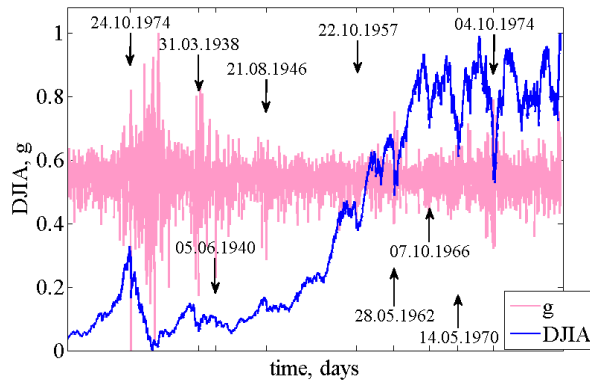
№	Interval	Days in correction	DJIA High Price	DJIA Low Price	Decline, %
1	03.09.1929-29.10.1929	41	381,17	230,07	39,64
2	01.03.1938-31.03.1938	23	130,47	98,95	24,15
3	08.04.1940-05.06.1940	42	151,29	113,25	25,10
4	21.08.1946-10.09.1946	14	200,00	167,30	16,35
5	30.07.1957-22.10.1957	60	508,93	419,79	17,51
6	19.03.1962-28.05.1962	50	720,38	576,93	19,91
7	18.07.1966-07.10.1966	59	888,41	774,32	12,84
8	09.04.1970-26.05.1970	34	792,50	631,16	20,35
9	24.10.1974-04.10.1974	52	805,77	584,56	27,45
10	02.10.1987-19.10.1987	12	2640,99	1738,74	34,16
11	17.07.1990-23.08.1990	28	2999,75	2483,42	17,21
12	01.10.1997-21.10.1997	15	8178,31	7161,14	12,43
13	17.08.1998-31.08.1998	11	8533,65	7640,27	18,44
14	14.08.2002-01.10.2002	34	9053,64	7286,27	19,52
15	16.10.2008-15.12.2008	42	11715,18	8175,77	30,21
16	09.08.2011-22.09.2011	32	12190,01	10733,83	11,94
17	18.08.2015-25.08.2015	6	17511,34	15666,44	10,53
18	29.12.2015-20.01.2016	16	17720,98	15766,74	11,02
19	03.12.2018-24.12.2018	15	25826,42	21792,19	15,62

According to our classification events with the number (1, 10, 13, 15, 19) are crashes, all the rest are critical events. Further on, we will consider those entropy indicators that, from the point of view of identification and prevention of crisis phenomena are the most informative. Analysis of the whole set of such indicators allowed us to identify 3 of them: Permutation, Shannon and Tsallis entropies.

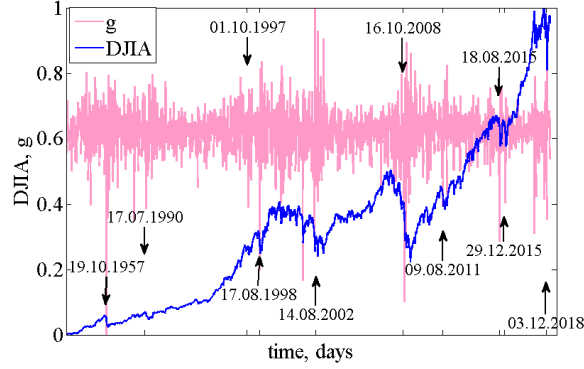
Results were obtained within the framework of the algorithm of a moving window. For this purpose, the part of the time series (window), for which there were calculated measures of complexity, was selected, then, the window was displaced along the time series in a five-day increment and the procedure repeated until all the studied series had exhausted. Worth to note that if the length of the time window is too wide, several crises may entire it and our indicators will not reflect future entire changes correctly. Also, the window cannot be too narrow because the measure of complexity fluctuates noticeably and requires smoothing. During the experiments, we found that the window 500 represents the optimal results.

Further, comparing the dynamics of the actual time series and the corresponding measures of complexity, we can judge the characteristic changes in the dynamics of the behavior of complexity with changes in the stock index. If the constructed measure of complexity behaves in a definite way for all periods of crashes, for example, decreases or increases during the pre-critical period, then it can serve as an indicator or precursor of such a crashes phenomenon.

In the Figure 1 two output DJIA time series, normalized returns  $g(t)$  with emphasized crisis states are presented.



a)



b)

**Fig. 1.** The standardized dynamics and returns  $g(t)$  of DJIA daily values for the first (a) and the second (b) periods. The arrows indicate the corresponding crash or critical event.

As we can see from Figure 1, for most crashes and critical events, normalized profitability  $g(t)$  increases considerably in some cases. This behavior signals about abnormal phenomena in the market, and deviation from the normal law of distribution. Such characteristic can serve as indicator of critical and crash phenomena.

#### 4 Permutation Entropy

Permutation entropy (PE<sub>n</sub>) is a measure from the chaos theory, proposed by Bandt and Pompe [25], which is characterized by its conceptual simplicity and computational speed. The idea of PE<sub>n</sub> is based on usual Shannon entropy [26], but it uses permutation patterns-ordinal relations between values of the system. These patterns consider the order among times series and relative amplitude of values in each vector instead of individual values. In this way, if compared with other measures of complexity, this approach has many advantages over the others as robustness to noise and invariance to nonlinear monotonous transformations [27]. The PE<sub>n</sub> can be described as follows.

Let's consider time series  $S(t) = \{x_k | k = 1, \dots, N\}$ . For a given time series can be constructed embedding vector:

$$S_m \rightarrow (x_{m-(D-1)L}, x_{m-(D-2)L}, \dots, x_{m-L}, x_m),$$

where  $D$  is the length of embedding dimension, and  $L$  is the time delay. For constructing ordinal patterns each element of the vector can be defined by order

$$x_{m-j_0L} \geq x_{m-j_1L} \geq \dots \geq x_{m-j_{D-2}L} \geq x_{m-j_{D-1}L}.$$

Therefore, for the vector  $S_m$  there will be  $D!$  possible permutations  $\pi = (j_0, j_1, \dots, j_{D-1})$ . Then, we obtain the probability for each  $\pi$  and construct the ordinal pattern probability distribution  $P = \{p_i(\pi_i), i = 1, \dots, D!\}$  required for the entropy estimation. The Permutation entropy (denoted by  $S[P]$ ) of the time series  $S(t)$  is defined as:

$$S[P] = - \sum_{i=1}^{D!} p(\pi_i) \ln p(\pi_i).$$

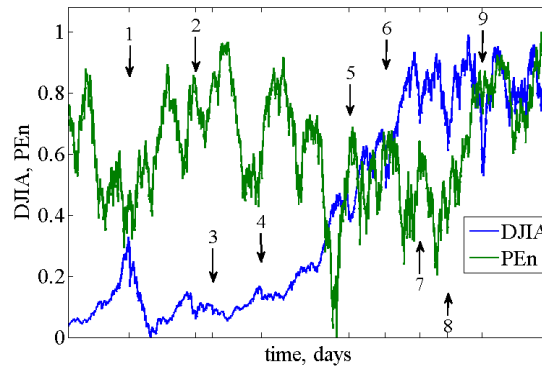
To take more convenient values, we normalize permutation entropy  $S$  associated with probability distribution  $P$ :

$$E_s[P] = \frac{S[P]}{S_{\max}},$$

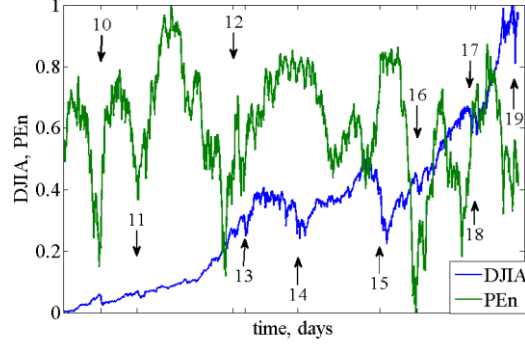
where  $S_{\max} = \ln D!$ , and normalized permutation has a range  $0 \leq E_s[P] \leq 1$ .

The PEn is not restricted to the time series that is representative of low dimensional dynamical systems. The embedding length  $D$  is paramount of importance because it determines  $D!$  possible states for the appropriate probability distribution. With small values such as 1 or 2, parameter  $D$  will not work because there are only few distinct states. Furthermore, for obtaining reliable statistics and better detecting the dynamic structure of data,  $D!$  should be relevant to the length of the time series or less [20]. We discovered that  $D = 5, 6$ , or  $7$  indicate better results. Therefore, the value of  $H_s[P]$  gives us to understand rather we have predictable and regular time series or absolutely randomize process.

Figure 2 shows the PEn calculation results both for first (a) and second (b) periods of the DJIA index time series (the window length is 500 days, the offset is 5 days). Arrows indicate crashes and critical events according to their number in the table.



a)



b)

**Fig. 2.** The dynamics of Permutation entropy for first (a) and second (b) periods of the DJIA index time series.

As we can see from the figures above, Permutation entropy decreases for both crashes and critical events, signaling the approaching of a special state.

## 5 Indicators of crisis states based on Shannon and Tsallis entropies

For a given discrete probability distribution  $P = \{p_i, i = 1, \dots, M\}$ , Shannon entropy (ShEn) is defined as:

$$S[P] = -\sum_{i=1}^M p_i \ln p_i.$$

For any scale  $c \neq 0$ , ShEn is defined as:

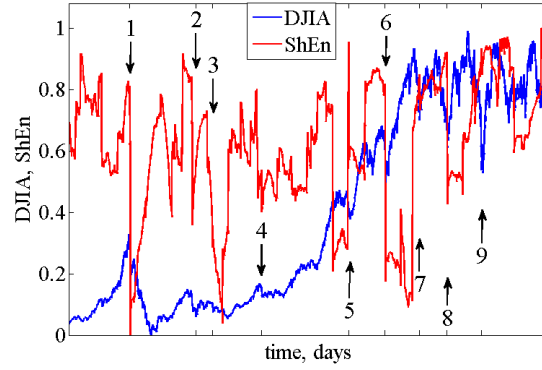
$$S_c = \left[ \sum_{i=1}^M p_i (\ln p_i^{-1})^c \right]^{1/c}.$$

where  $p_i$  stands for the occurrence probability of one event. For scale  $c=0$ , the  $c$ -th order of ShEn is defined as:

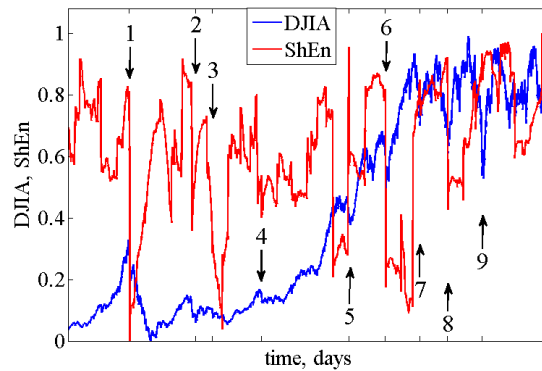
$$S_c = \prod_{i=1}^M e^{p_i (\ln p_i^{-1})}.$$

These equations are jointly called as the generalized ShEn. When  $c=1$ , generalized entropy transforms into the standard Shannon entropy.

Figure 3 demonstrates the dynamics of DJIA index and calculated ShEn for them with parameters: the length of window is 500 days and window offset is 5 days.



a)



b)

**Fig. 3.** Dynamics of Shannon entropy and the DJIA index for first (a) and second (b) periods.

It can be noticed that in crashes or critical periods ShEn decreases, indicating abnormal phenomena that took place in the stock market. With the lower value of entropy, we have less complexity in the system (crisis period), and when the value of entropy becomes higher, the system becomes more chaotic and randomized. It's worth considering that this indicator responds significantly to those events that have had rapidly price loss in a short period of time.

Tsallis [28] introduced a new concept that allows describe non-extensive (non-additive) systems with the entropic index  $q$  which is the measure of non-additivity such as:

$$S(A+B) = S(A) + S(B) - (1-q) \cdot S(A) \cdot S(B).$$

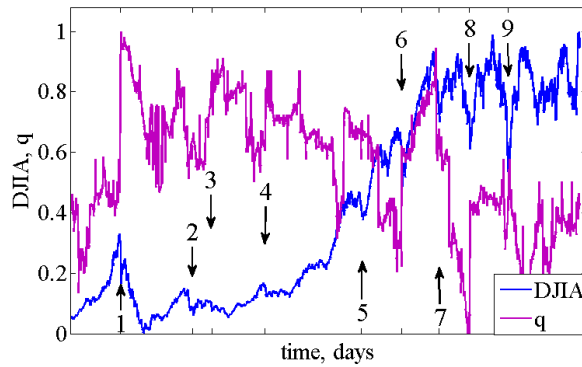


He took the standard Shannon's entropy expression and instead of the logarithmic one, he introduced power function  $\ln(x) \Rightarrow \ln_q(x) \Rightarrow (x^{1-q} - 1) / (1 - q)$ . In the limit as  $q \rightarrow 1$ ,  $\ln_q(x)$  turns into real logarithm. For the entropic index  $q$  new entropy is defined as:

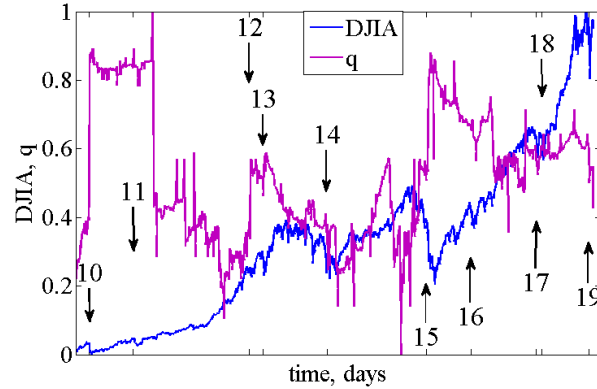
$$S_q = -\sum_i (p_i^q \ln_q(p_i)) = (1 - \sum_i p_i^q) / (q - 1),$$

where new  $q$ -entropy can give description of systems with "long memory" in which interacts not only with nearest neighbors, but with entire systems or with some of its parts. With the entropic indicator  $q$  it is possible to determine different characteristics of complex systems. When the entropic index  $q < 1$ , it means that in system dominates unusual anomalous phenomena. With the entropic index  $q > 1$  determined recurring phenomena in the system. In the case, when the entropic index  $q \rightarrow 1$ , Tsallis entropy converges to the standard ShEn. The main consequence of such substitution is that entropy with the entropic index  $q$  is an already non-extensive function.

In Figure 4 we present comparative dynamics of the DJIA index with corresponding value of  $q$  which is considered to be an indicator of crisis states. The results were obtained for window of length 1000 days and window offset 5 days.



a)



b)

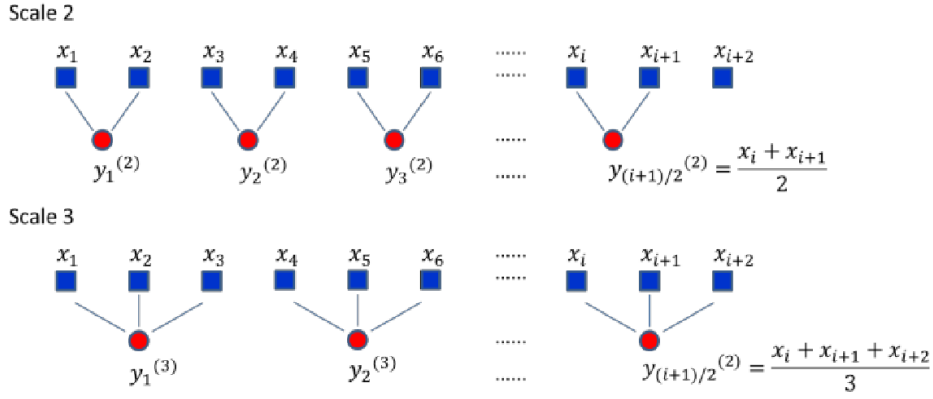
**Fig. 4.** Comparative dynamics of DJIA index time series with corresponding value of  $q$  coefficient for first (a) and second (b) periods.

For Figure 4 in most crashes and critical events, the entropic index  $q$  rapidly and asymmetrically grows and indicates the increasing in complexity of the system at that time. It is worth considering that with the window of less width and step, we would have taken results with higher accuracy.

As a result, Shannon's entropy is an indicator, and the parameter  $q$  is a precursor of crisis phenomena.

## 6 Multiscale entropy

One of the properties of complex systems is manifested in their scale invariance: a complex system behaves universally, regardless of the scale. This feature is found in the quantitative description of entropy, which is known as Multiscale entropy (MSE). The algorithm of MSE was developed by Costa [29] to quantify the complexity of time series for a range of scales (see Figure 5).



**Fig. 5.** Schematic illustration of the coarse-graining for scales 2 and 3.

The MSE method includes two sequentially executed procedures:

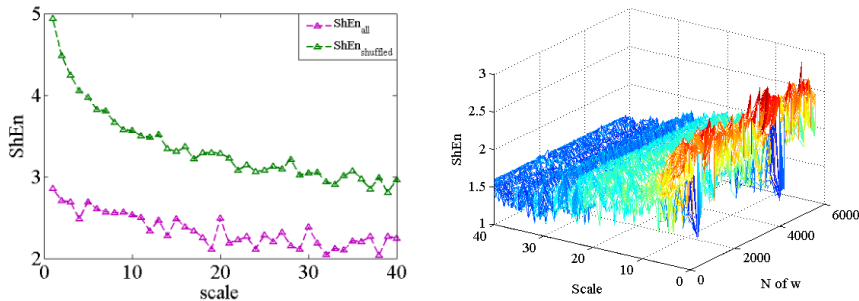
(1). The process of coarse-graining of the initial time series. To obtain coarse-grained time series at a scale factor of  $\tau$ , time series divides by the non-overlapping windows of the length  $\tau$  as shown in Figure 5, and the size of which increases with the transition from scale to scale. Then, the values inside each part of the time series are averaged. In other words, each element  $y_j^{(\tau)}$  for the coarse-grained times series can be estimated according to the following equation:

$$y_j^\tau = \frac{1}{\tau} \sum_{i=(j-1)\tau+1}^{j\tau} x_i, 1 \leq j \leq N/\tau.$$

The length for each coarse-grained time series depends on the length of the window and equals to  $N/\tau$ . For a scale of 1, the coarse-grained time series identical to the original one.

(2). The computation of the corresponding measure of entropy as a measure of complexity for each coarse-grained time series. This measure then plotted as the function of the scale factor  $\tau$  (according to our case, we estimate Shannon entropy).

As a result, in the Figure 6 we can see MSE calculated for the entire DJIA index time series



a)

b)

**Fig. 6.** The map of multiscaling components for estimated Shannon entropy for the entire DJIA index time series.

Figure 6 (a) shows the Multiscale Shannon entropy calculated for the entire output and shuffled DJIA time series. The fact that the shuffled time series is more complex suggests that the Shannon entropy is a measure of chaotic rather than complexity. Figure 6 (b) is a three-dimensional representation of Shannon entropy calculated with a window length of 1000 days, a window offset of 5 days and scale factor of 40. It is seen that at small scales, the dynamics of MSE coincide with Figure 3 and even at the presented scales, it does not tend to zero.

## 7 Conclusions

Anomalous fluctuations of the daily values of the Dow Jones Industrial Average index for the period from 2 January 1920 to 18 March 2019 have been analyzed; 5 crashes (short, time-localized drops) and 14 critical events (price changes that are noticeable but occurring over a longer period of time) have been identified. The hypothesis on the correlation of complexity measures and crisis phenomena, proposed on the basis of the theory of complex systems, has been tested using the example of entropy complexity measures. The entropy (including multiscale versions) of Shannon, Tsallis, and permutations are calculated within the framework of the moving window algorithm from a set of entropy indicators. The change in the absolute values of the entropy indices in the period of the crash and critical events indicates a change in the complexity of the system, which makes it possible to treat them as informational measures of complexity. Comparison of the entropy characteristics with the values of the DJIA index opens up the possibility of indicating or even early warning of crisis phenomena. In the case of Shannon's entropy, the complexity of the system experiences a race itself at the moment of crisis and is its indicator. The entropy of Tsallis and permutations react to crisis phenomena with some anticipation, which makes it possible to use them as precursors of crises.

Thus, the developed methodology for constructing indicators and precursors of crisis phenomena does not use cumbersome, costly and still debatable methods for predicting price fluctuations and their trends, carry out early diagnostics of crisis phenomena and take preventive measures anticipating significant financial losses.

## References

1. Sornette, D.: *Why Stock Markets Crash: Critical Events in Complex Systems*. Princeton University Press. (2003)
2. Zemba, W.T., Liao, S., Zhitlukhin, M.: *Stock Market Crashes: Predictable and Unpredictable and What to Do About Them*. World Scientific (2018)

3. Chen, L., Qiao, Z., Wang, M., Wang, C., Du, R., Stanley, H. E.: Which Artificial Intelligence Algorithm Better Predicts the Chinese Stock Market? *IEEE Access* 6, 48625-48633 (2018)
4. Chong, E., Han, C., Park, F. C.: Deep learning networks for stock market analysis and prediction: Methodology, data representations, and case studies. *Expert Systems With Applications* 83, 187-205 (2017)
5. Li, S.I., Yoo, S.J.: Multimodal Deep Learning for Finance: Integrating and Forecasting International Stock Markets. <https://arXiv:1903.06478v1> [q-fin.CP] (2019)
6. Wang, M., Zhao, L., Du, R., Wang, C., Chen, L., Tian, L., Stanley, H. E.: A novel hybrid method of forecasting crude oil prices using complex network science and artificial intelligence algorithms. *Applied Energy* 220, 480–495 (2018)
7. Kaizoji, T., Sornette, D. Market Bubbles and Crashes. <https://arXiv:0812.2449> [q-fin.RM] (2008)
8. Filimonov, V., Demos, G., Sornette, D.: Modified Profile Likelihood Inference and Interval Forecast of the Burst of Financial Bubbles. *Quantitative Finance* 17(8), 1186 (2017) <https://doi.org/10.1080/14697688.2016.1276298>
9. Fievet, L., Sornette, D.: Calibrating emergent phenomena in stock markets with agent based models. *PLoS ONE* 13(3) : e0193290. <https://doi.org/10.1371/journal.pone.0193290>
10. Diaz, J.: Evidence of Noisy Chaotic Dynamics in the Returns of Four Dow Jones Stock Indices. *Annual Review of Chaos Theory, Bifurcation and Dynamical System* 4, 1-15 (2013)
11. Duarte, B., Machado, J., Duarte, M.: Dynamics of the Dow Jones and the NASDAQ Stock Indexes 61(4), 691-705 (2010)
12. Newman, M. E. J.: Complex Systems: A Survey. *American Journal of Physics* 79, 800-810 (2011) <https://doi.org/10.1119/1.3490372>
13. Nikolis, G., Prigogine, I: Exploring complexity. An Introduction. W. H. Freeman and Company, New York (1989)
14. Mantegna, N., Stanley, E.: An Introduction to Econophysics: Correlations and Complexity in Finance. Cambridge Univ. Press, Cambridge UK (2000)
15. Charles, A., Darne, O.: Large shocks in the volatility of the Dow Jones Industrial Average index: 1928-2013. *Journal of Banking & Finance* 43, 188-199 (2014) <https://doi.org/10.1016/j.bankfin.2014.03.022>
16. Gradojevic, N., Gencay, R.: Was it Expected? Aggregate Market Fears and Long Range Dependence. *Journal of Empirical Finance* 17(2), 270-282 (2010) <http://dx.doi.org/10.2139/ssrn.959547>
17. Danylchuk, H., Derbentsev, V., Soloviev, V., Sharapov, A.: Entropy analysis of dynamics properties of regional stock market. *Science and Education a New Dimension. Economics* 4(2), 15-19 (2016)
18. Pele, T., Lazar, E., Dufour, A.: Information Entropy and Measures of Market Risk. *Entropy* 19(5), 1-19 (2017) <https://doi.org/10.3390/e19050226>
19. Lim, R.: Rapid Evaluation of Permutation Entropy for Financial Volatility Analysis – A Novel Hash Function using Feature-Bias Divergence. Department of Computer Science, Imperial College of London, London (2014)
20. Gu, R.: Multiscale Shannon Entropy and its application in the stock market. *Physics A* 484, 215-224 (2017)
21. Wang, G.-J., Xie, C., Han, F.: Multi-Scale Approximation Entropy Analysis of Foreign Exchange Markets Efficiency. *Systems Engineering Procedia* 3, 201-208 (2012)
22. Fiedor, P.: Multiscale Analysis of the Predictability of Stock Returns. *Risks* 3(2), 219-233 (2015) <https://doi.org/10.3390/risks3020219>

23. Soloviev, V., Belinskiy, A.: Complex Systems and Crashes of Cryptocurrency Market. In: Ermolayev, V., Suárez-Fgueroa, M., Yakovyna, V., Mayr, H., Nikitchenko, M., Spivakovsky, A. (eds.) on ITC in Education, Research, and Industrial Applications. CCIS, vol 1007, pp 276-297. Springer, Cham (2018)
24. Bielinskyi, A., Soloviev, V.: Complex network precursors of crashes and critical events in the cryptocurrency market. In: Kiv, A., Semerikov, S., Soloviev, V., Striuk, A. (eds) Proceedings of the 1<sup>st</sup> Student Workshop on Computer & Software Engineering, CEUR Workshop Proceedings (CEUR-WS.org), vol 2292, pp 37-45. Kryvyi Rig, Ukraine (2018)
25. Bandt, C., Pompe, B.: Permutation entropy: A natural complexity measure for time series. *Phys. Rev. Lett.* 88(17), 2-4 (2002)
26. Shannon E.: A mathematical theory of communication. *The Bell System Technical Journal* 27(3), 379-423 (1948)
27. Kantz, H., Schreiber, T.: *Nonlinear Time Series Analysis*. 2<sup>nd</sup> edition. Cambridge University Press, London (2003) <http://doi.org/10.1017/CBO9780511755798>
28. Tsallis C.: Nonextensive Statistics: Theoretical, Experimental and Computational Evidence and Connections. *Brazilian Journal of Physics* 29(1), 1-35 (1999) <http://doi.org/10.1590/S0130-97331999000100002>
29. Costa, M., Goldberger, A., Peng, C.-K.: Multiscale Entropy Analysis of Complex Physiologic Time Series. *Physical Review Letters* 89(6), 068102 (2002)

# Influence of the Country's Information Development on Its Tourist Attractiveness

Yuliia Lola<sup>1</sup>, Svetlana Prokopovich<sup>1</sup>, Olena Akhmedova<sup>1</sup>

<sup>1</sup> Simon Kuznets Kharkiv National University of Economics, 9-A, Ave. Nauki, Kharkiv, 61166 Ukraine

yuliia.lola@hneu.net, prokopovichsv@gmail.com, yelena.akhmedova@hneu.net

**Abstract.** A number of studies have researched the effects of tourism on transportation system, hotel industry, economic efficiency and environment. This paper examines the influence of the information and communication technologies development on the inbound tourism intensity. The correlation and regression analysis has been used to identify the relationship between the Travel and Tourism Competitiveness Index, the Information and Communication Technology Development Index and International tourism arrivals. The results demonstrate that there is a close link between the countries' tourist attractiveness and the level of their information and communication development. However, it is not equal for different countries, which are grouped by the level of intensity of tourism arrivals, the level of the country's attractiveness and its information and communication technologies development. Besides, the country's information and communication technologies development has little effect on the inbound tourism intensity

**Keywords:** tourist attractiveness of a destination, information and communication development of a country, the travel and tourism competitiveness index, international tourism arrivals.

## 1 Introduction

The contemporary unification of the world society into a single information and communication network and the transformation of information technologies into the generative force of socio-economic development contributes to the close interconnection between countries, regions and societies of different nations. Most countries are actively using Internet space to shape the country's image (including tourist image). Mainly because it is one of the most important tools for creating an appropriate image of the country as a tourist destination that can greatly increase the intensity of the inbound tourism flow. In this regard, the study of the impact of the country's information and communication technologies development on the tourism and travel development is relevant and requires further theoretical and practical research.

## 2 Theoretical development and hypotheses formulation

Tourism development affects the development of a range of other areas of economic activity. Inbound and outbound tourism has bidirectional causality with air transportation (Syed Abdul Rehman Khan and other, 2017). Air transport and tourism are highly connected. Researches show that tourist-oriented airports may achieve higher efficiency levels than non-touristic ones (Xosé Luis Fernández, Pablo Coto-Millán, Benito Díaz-Medina, 2018).

The level of tourism development is estimated by the global index. The Travel & Tourism Competitiveness Index has been the subject of some methodological criticism, such as the arbitrary weighting of variables. There is an alternative methodology for calculating this index based on two points of reference to propose a new standardization. A synthetic index that measures the state of the pillar in the worst position, as well as other alternative indices, is calculated (Juan Ignacio Pulido-Fernández, Beatriz Rodríguez-Díaz, 2019).

Depending on how the variables are included in the underlying technology specification, the same tourism index can be oriented towards the assessment of either the private or the public sector's effectiveness (Walter Briec and other, 2018).

Trade openness, climate change and intensity of market competition increase tourism efficiency in China. Tourism efficiency improvement in China was mainly driven by technological improvement (Sami Chaabouni, 2019).

UNESCO's World Heritage inscription is considered to positively influence tourism demand. However, relevant econometric research has yielded inconsistent results. A sub-group analysis identifies different factors in developing vs. developed countries and cultural vs. natural WHS types. (Yang LanXue, Thomas E.Jones, 2019).

The expansion of tourism translates into an environmental deterioration of the destination (risk dimension) and, furthermore, it substantiates that there are specific variables connected to environmental sustainability (regulatory dimension) that contribute to greater tourism growth, so that the relationship between tourism and environmental sustainability is bidirectional (Juan Ignacio Pulido-Fernández, Pablo Juan Cárdenas-García, Juan Antonio Espinosa-Pulido 2019).

The studies suggest that the effect of growth rate of total foreign tourist arrivals on hotel equity return is asymmetric and state-dependent, conditional on the distributions of hotel equity return. The study further identified that GTA has a significant influence only on equity returns of hotels with a small size (Ming-Hsiang Chen, 2016).

The shift of our view on information technology in tourism research from a primarily a marketing-driven tool to a knowledge creation tool due to new technological conditions such as the smartphone, drone, wearables, new connectivity and big data is recognized. Some possible future research problems and challenges regarding our existing views of the relationship between information technology and tourism are studied (Zheng Xiang, 2018).

Not only ICTs empower consumers to identify, customise and purchase tourism products but they also support the globalisation of the industry by providing effective tools for suppliers to develop, manage, and distribute their offerings worldwide (Buhalis, 1998).



Buhalis (1998) stated that potential tourists have become more independent and sophisticated on using a wide range of tools to arrange for their trips (such as Expedia, Google and Kayak, visitbritain.com), web 2.0 portals, wayn and tripadvisor, kelkoo).

Information Search is a significant part of the purchase decision process and was revolutionised as a result of the Internet. ICTs not only reduce uncertainty and perceived risks but also enhance the quality of trips (Fodness & Murray, 1997).

The quality of the website, Digital Marketing, Social Networking, Multimedia, Mobile Technologies and Intelligent Environments are the main key factors of ICT in Tourism (Elisabete Paulo Morais & other, 2016).

A Virtual Travel Community (VTC) makes it easier for people to obtain information, maintain connections, develop relationships, and eventually make travel-related decisions (Stepchenkova, Mills & Jiang, 2007).

Increasingly the impacts of ICTs are becoming clearer, as networking, dynamic interfaces with consumers and partners and the ability to re-develop the tourism product proactively and reactively are critical for the competitiveness of tourism organizations (Buhalis, D., & Law R., 2008).

The analysis of the mentioned resources has allowed hypothesizing the following:

**Hypothesis 1.** Information development of the society contributes to the improvement of the country's tourist attractiveness.

**Hypothesis 2.** The development of information and communication technologies in the countries across the globe positively influences the inbound tourism intensity.

### 3 Methods

The methods of multivariate statistical analysis, such as Descriptive Statistics, the multiple regression, the cluster analysis were used to study the influence of information and communication technologies on tourism. These statistical methods were implemented with the StatSoft's software package Statistica. This package is well balanced with the "power / convenience ratio", has a wide range of functional data analysis algorithms and has wide graphical capabilities for data visualization.

To carry out the research, the global indices and variables of tourism development were selected:

The Travel and Tourism Competitiveness Index (TTCI), which reflects the level of the country's attractiveness for both tourists and also investors and representatives of the tourism business. This index includes the characteristics of the following framework: Enabling Environment, Travel and Tourism Policy and Enabling Conditions, Tourism and Transport Infrastructure, Natural and Cultural Resources [12];

The Information and Communication Technologies Development Index (ICT) reflects the level of networked infrastructure and access to ICTs, the level of use of ICTs in the society and more efficient and effective ICT use [11].

International tourism arrivals (ITA) is one of the main indicators that reflects the effectiveness of all the measures adopted for the development of tourism in the country [3].

The objects of research are 80 countries of the world. The variables are the data for 2016. The countries without sufficient data were excluded from the database.

## 4 Results

In order to study the influence of the country's information and communication development on tourism development, the following algorithm of the research has been proposed:

Stage 1. Selection of the initial variables.

Stage 2. Research of the basic statistical characteristics of the selected variables.

Stage 3. Verification of the first hypothesis on the basis of the correlation-regression analysis methods.

Stage 4. Verification of the second hypothesis on the basis of the correlation-regression and cluster analysis methods for the whole array of initial data and within the scope of separate groups of countries, which are similar according to the level of tourism activity.

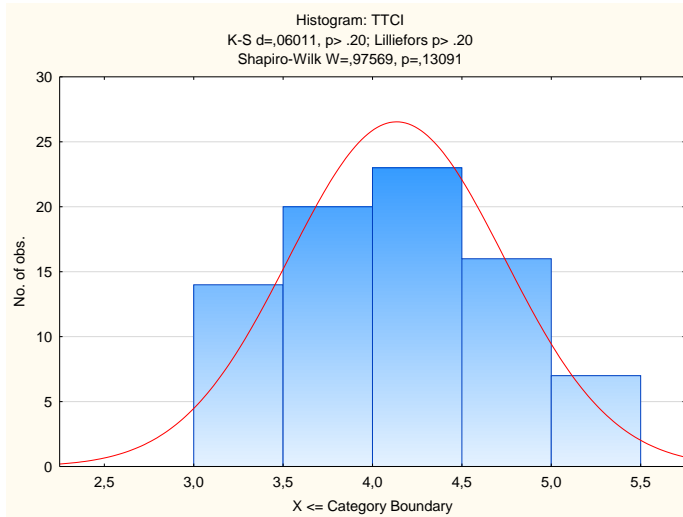
For implementation of the first stage of the algorithm, the following variables were selected: Travel and Tourism Competitiveness Index (TTCI), Information and Communication Technologies Development Index (ICT) and International Tourism Arrivals (ITA).

The descriptive statistics was used to process, systematize and provide quantitative description of the empirical data by means of the main statistical indicators. The implementation of the second stage of the study presupposed the calculation of the following characteristics: Mean, Median, Mode, Frequency of Mode, Minimum, Maximum, Variance, Standard Deviation, Coefficient of Variation, Skewness, Kurtosis, as well as histogramming. The results of calculation are presented in Table.1.

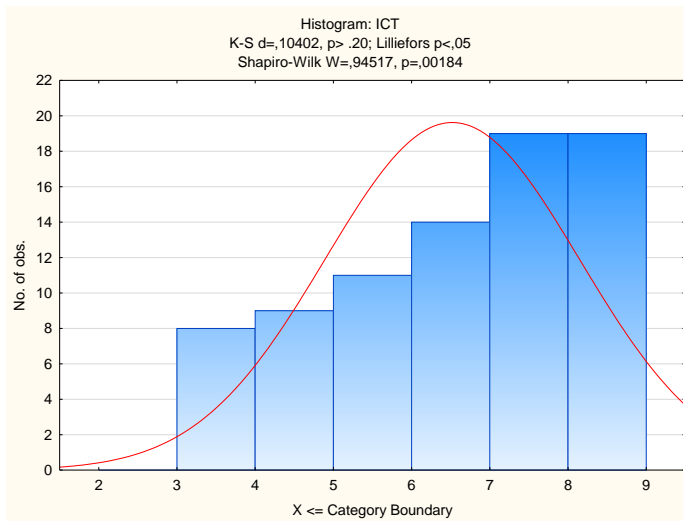
**Table 1.** Descriptive Statistics

Variable	Descriptive Statistics											
	Valid N	Mean	Median	Mode	Freq. of Mode	Min	Max	Variance	Std. Dev.	Coef. Var.	Skewn.	Kurtos.
TTCI	80	4,13	4,125	3,910	3	3,09	5,43	0,36	0,60	14,542	0,2079	-0,7614
ICT	80	6,52	6,875	-	-	3,03	8,98	2,66	1,63	24,946	-0,4806	-0,7991
ITA	80	12684,2	5460,0	-	-	121,0	82600,0	316498734	17790,4	140,256	2,3697	5,6854

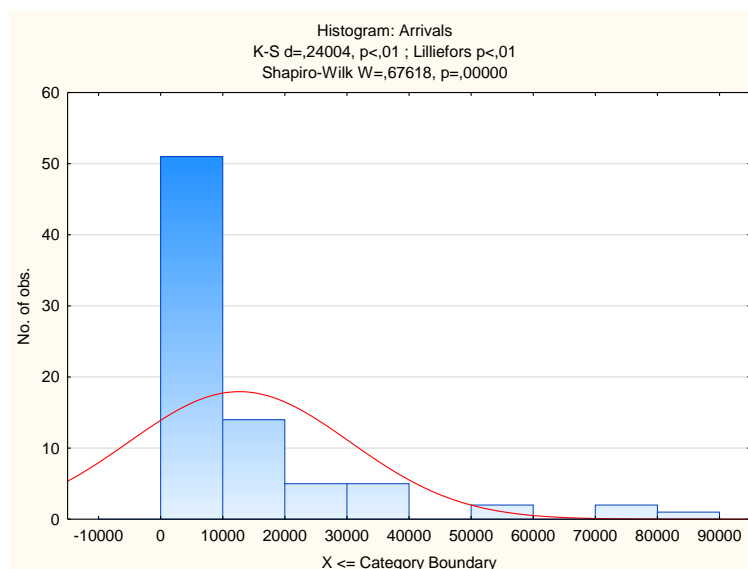
The results of the histogramming of distribution for each of the studied variables are presented in Fig. 1 – 3.



**Fig. 1.** TTCl variable distribution histogram



**Fig. 2.** ICT variable distribution histogram



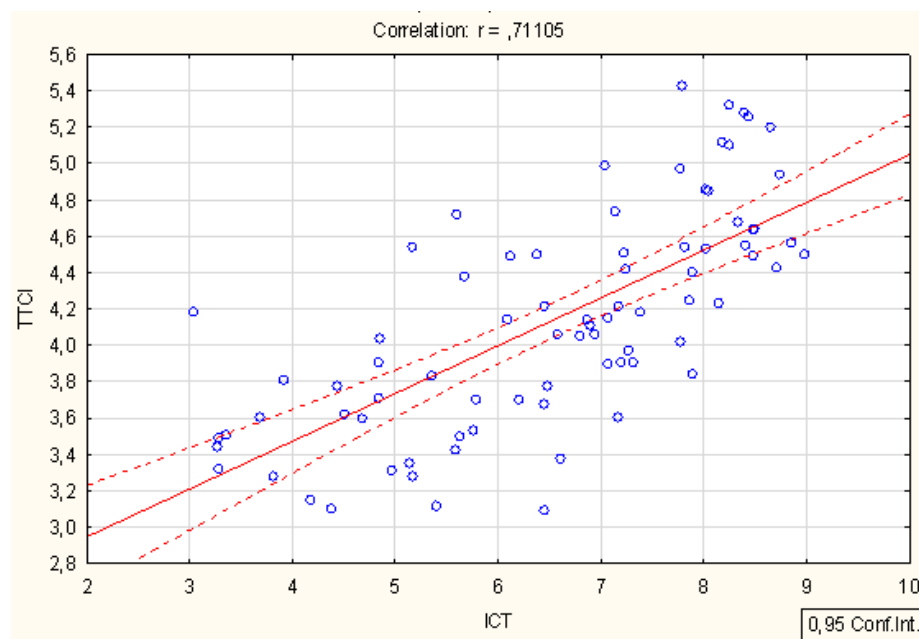
**Fig. 3.** ITA variable Distribution Histogram

According to the results of the analysis of the obtained statistical characteristics (see Table 1) and distribution histograms (see Figures 1-3), the following conclusions can be made:

- the TTCI variable has a distribution close to normal. This is evidenced by the proximity of the mean, mode and median, as well as small values of the skewness and kurtosis. This variable has the least value of the coefficient of variation (14,52);
- the ICT variable also has a distribution rather close to normal. Its average value is close to the median. But unlike the TTCI variable, it has a slightly larger range (from 3.03 to 8.98) and a larger coefficient of variation (24.95). It should be noted that almost half of the world's countries (38 out of 80) fall into the last two intervals with values of 7 to 8 and from 8 to 9. This means that a significant part of the countries in the considered group has a high level of development of information and communication technologies (ICT);
- the ITA variable is significantly different from the previous two. First of all, it has a completely different unit of measurement and dimension, therefore, during further research with the simultaneous use of the TTCI and ICT variables, the calculations will be made on the basis of the standardized data. Secondly, the distribution of this variable is quite distant from normal. This is evidenced by the large difference between the mean and the median (12 684.2 and 5 460.0 thousand persons respectively), as well as the statistical criteria of the Kolmogorov-Smirnov (K-S test), Shapiro-Wilk test and Lilliefors test. For the distribution of this variable the right-side bias is characteristic (the skewness equals 2.37) and significant elevation (the kurtosis is equal to 5.69). In 2016, this variable was significant (from 121 to 82,600 people), more than 50 countries had the value of this variable up to 10,000 thousand people, in France

this value was more than 80,000, and in Spain and United States – it ranged from 70,000 to 80,000 thousand people.

The verification of the first hypothesis that the information development of the society contributes to the improvement of the country's tourist attractiveness was carried out during the implementation of the third stage of the study. A pair correlation coefficient between the TTCI and ICT variables was calculated according to the data from all 80 countries. In 2016 it was equal to 0.711 that indicates a fairly close direct linear relationship between these variables. The graphic representation of this connection is given in Fig. 4.



**Fig. 4.** Dispersion field (correlation field) between factors

The dispersion field proves a linear relationship between TTCI and ICT, therefore, we can accept the hypothesis 1 that the greater the information development of the country is, the better the tourism and travel sector is developed in this country. This allows putting forward the second hypothesis that the development of information and communication technologies in the countries of the world positively influences the intensity of inbound tourism.

Thus, the implementation of the fourth stage involves verification of the second hypothesis that involves the following sequence of steps:

Step 1. Determination of the pair correlation coefficients between the resulting ITA variable and factor variables of TTCI and ICT.

Step 2. Construction of the multiple regression based on the standardized data of the type:

$$\widehat{ITA}_{st} = a_1 \cdot TTCI_{st} + a_2 \cdot ICT_{st}, \quad (1)$$

where  $a_1$  ta  $a_2$  are unknown parameters that are evaluated by the least squares method.

Step 3. Distribution of countries into homogeneous groups according to the ITA, TTCI and ICT variables on the basis of the cluster analysis methods.

Step 4. Construction of the multiple regression (1) for each of the clusters.

Step 5. Making conclusions as to the hypothesis acceptance or rejection.

In the result of implementation of the first step the following values of the pair correlation coefficients have been received:  $r_{ITA,TTCI} = 0,6574$ ;  $r_{ITA,ICT} = 0,2734$ . These values mean that there is a direct linear link of the moderate level between ITA and TTCI, but between ITA and ICT there is a direct but weak link.

The obtained values are not sufficient for accepting or rejecting the hypothesis 2. Therefore, during the second step, the following equation of multiple regression was constructed:

$$\widehat{ITA}_{st} = 0,9283 \cdot TTCI_{st} - 0,3915 \cdot ICT_{st}.$$

This regression equation is statistically significant in terms of Fisher's criterion ( $F = 40.32$ ), and separate parameters according to Student's criterion ( $t_{a_1} = 8.29$ ,  $t_{a_2} = -3.47$ ). The coefficients of the multiple correlation ( $R = 0.713$ ), the determination ( $R^2 = 0.508$ ) and the corrected determination coefficient ( $R_{adj}^2 = 0.489$ ) indicate a sufficient quality of the model. There is no autocorrelation of the errors in this model (the statistics of Darbine-Watson are approximately equal to 2, and the cyclic coefficient of autocorrelation is close to 0). Thus, this model can be used for analysis and forecasting.

We have analysed the problem under study according to this model. As can be seen from the obtained regression equation, compared with the pair correlation coefficients, there is a significant increase of the influence of TTCI on ITA (from 0.6574 to 0.9293), the simultaneous change of direction and the increase of the influence of ICT on ITA (from + 0.2734 to -0.3915). To answer the question whether these changes are only due to the multicollinearity that are present in the model, or in fact there is an inverse relationship between ICT and ITA, partial correlation coefficients have been calculated and their statistical significance checked. The results of calculations are given in Table 2.

**Table 2.** Results of correlation coefficients calculations

Variable	Variables currently in the Equation; DV: ITA						
	b* in	Partial Cor.	Semipart Cor.	Tolerance	R-square	t(77)	p-value
TTCI	0,936420	0,684528	0,658439	0,494413	0,505587	8,23980	0,000000
ICT	-0,392394	-0,366155	-0,275910	0,494413	0,505587	-3,45277	0,000905

As can be seen from Table 3, the value of the partial coefficients is:  $r_{ITA,TTCI}^{part} = 0,6845$ ;  $r_{ITA,ICT}^{part} = -0,3661$  and they are statistically significant according to the Student's criterion.

During the next, *third step*, using the cluster analysis methods, we obtain homogeneous groups of countries. The grouping of countries is based on the hierarchical method of full communication, which allows clearly divide the countries into two, three, or four clusters. The division into 2 clusters is not informative. If we divide countries into 4 clusters, then the last cluster will consist of only three countries (28, 69 and 77). Therefore, it is rational to divide countries into three clusters, which corresponds to the logical distribution of countries with high, medium and low intensity of foreign tourists' arrivals.

Based on the iterative method of clustering k-means, the following cluster results have been obtained. The first cluster includes 30 countries with the low inbound tourism activity (Cluster contains 30 cases). These countries are listed in Table 3.

**Table 3.** Members of Cluster Number 1 and Distances from Respective

Cluster Center								
Case No.	Country	Distance	Case No.	Country	Distance	Case No.	Country	Distance
C_1	Albania	0,2130	C_29	Georgia	0,370	C_56	Nicaragua	0,569
C_3	Armenia	0,3328	C_32	Guatemala	0,5336	C_58	Paraguay	0,448
C_6	Azerbaijan	0,5073	C_33	Honduras	0,5623	C_59	Peru	0,479
C_9	Bhutan	0,4266	C_36	India	0,961	C_60	Philippines	0,119
C_10	Bosnia and Herzegovina	0,4561	C_37	Iran, Islamic Rep,	0,287	C_63	Romania	0,626
C_13	Cambodia	0,5963	C_41	Jamaica	0,166	C_65	Serbia	0,649
C_17	Colombia	0,3328	C_44	Kyrgyz Republic	0,455	C_70	Sri Lanka	0,421
C_23	Dominican Republic	0,1642	C_51	Moldova	0,723	C_75	Ukraine	0,428
C_24	Ecuador	0,3597	C_52	Mongolia	0,244	C_79	Venezuela, RB	0,288
C_25	El Salvador	0,4453	C_53	Montenegro	0,585	C_80	Vietnam	0,348

Besides, these countries have a very low level of tourism potential (TTCI), information, and communication technologies development (ICTs). Under the current conditions of certain instability, Ukraine is referred to this group.

The second cluster includes 38 countries with an average level of inbound tourism activity (Cluster contains 38 cases) and is presented in Table 4.

**Table 4.** Members of Cluster Number 2 and Distances from Respective

Cluster Center								
Case No.	Country	Distance	Case No.	Country	Distance	Case No.	Country	Distance
C_2	Argentina	0,423260	C_26	Estonia	0,290589	C_54	Netherlands	0,475310
C_4	Australia	0,754292	C_27	Finland	0,226476	C_55	New Zealand	0,445570
C_7	Barbados	0,512315	C_31	Greece	0,553923	C_57	Norway	0,429661
C_8	Belgium	0,201288	C_34	Hungary	0,421589	C_61	Poland	0,441428
C_11	Brazil	0,549649	C_35	Iceland	0,558500	C_62	Portugal	0,418383
C_12	Bulgaria	0,333957	C_38	Ireland	0,227274	C_64	Russian Federation	0,575004
C_14	Canada	0,696993	C_39	Israel	0,536582	C_66	Singapore	0,521162
C_15	Chile	0,473804	C_43	Korea, Rep,	0,558807	C_67	Slovak Republic	0,483337
C_18	Costa Rica	0,474334	C_45	Latvia	0,449582	C_68	Slovenia	0,264168
C_19	Croatia	0,215706	C_46	Lithuania	0,496977	C_71	Sweden	0,347542
C_20	Cyprus	0,372457	C_47	Luxembourg	0,420123	C_72	Switzerland	0,694621
C_21	Czech Republic	0,226697	C_48	Malaysia	0,738362	C_78	Uruguay	0,753103
C_22	Denmark	0,402136	C_49	Malta	0,261468			

Countries in the cluster 2 are characterized by the highest level of tourism potential (TTCI) and the average level of ICT development.

The third cluster includes 12 countries with the highest level of inbound tourism activity (Cluster contains 12 cases). This cluster is presented in Table 5.

**Table 5.** Members of Cluster Number 3 and Distances from Respective

Cluster Center					
Case No.	Country	Distance	Case No.	Country	Distance
C_5	Austria	0,701654	C_50	Mexico	0,941073

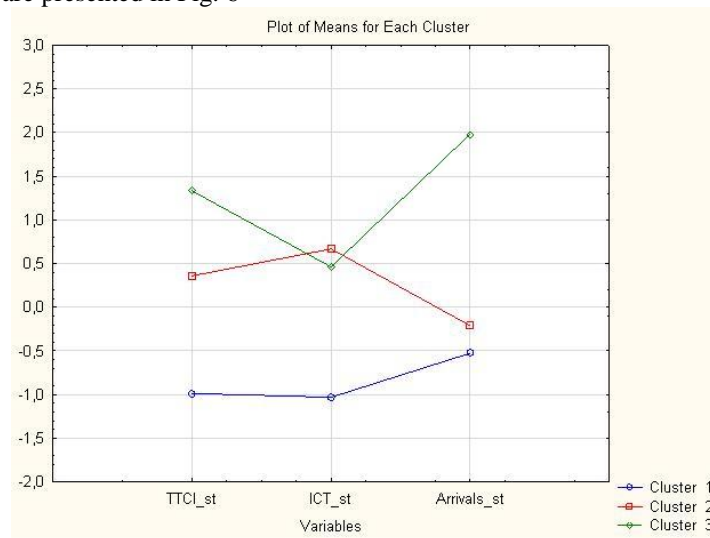


C_16	China	0,727240	C_69	Spain	1,028845
C_28	France	1,230744	C_73	Thailand	0,926716
C_30	Germany	0,654982	C_74	Turkey	0,916710
C_40	Italy	0,171680	C_76	United Kingdom	0,678250
C_42	Japan	0,932930	C_77	United States	0,968470

Countries of the latter cluster are characterized by the highest level of tourism potential development (TTCI) and rather high level of ICT.

It should be noted that the received country grouping by the level of tourism activity is sustainable, since the hierarchical method of complete dependence and the k-medium method yielded identical results, except for the country number 78 (Uruguay) which, according to the first method, was referred to the low-income countries development, and, according to the second method, it was referred to countries with an average level of development. As the final result we accept the one that gives the k-medium method, since this method minimizes intragroup variance and maximizes the intergroup, thus providing higher-quality clusterization.

The average means of the variables, according to which the clusterization was carried out, are presented in Fig. 6



**Fig. 6.** Average means of TPCI, ICT and ITA variables by clusters

Analysis of the means given in Fig. 6, allows to draw the following conclusions. First, the cluster number 1 is formed by the countries with the lowest values of the TPCI, ICT and ITA variables. The second cluster consists of the countries with an average level of TPCI and ITA, but with the highest level of ICT. The third cluster includes the countries with the highest levels of TPCI and ITA with high (but not the highest) level of ICT. In addition, the countries of the second and third clusters are characterised by the inverse dependence between the ITA and ICT variables. This is

also confirmed by the calculation of the pair correlation coefficients between the variables for each cluster separately. The results of calculations are presented in the Table 6.

**Table 6.** Matrices of the pair correlation coefficients for each cluster

Cluster 1				Cluster 2			
Variable	TTCI	ICT	ITA	Variable	TTCI	ICT	ITA
TTCI	1	-0,0763	0,4156	TTCI	1	0,4883	0,3444
ICT	-0,0763	1	-0,1822	ICT	0,4883	1	-0,1534
ITA	0,4156	-0,1822	1	ITA	0,3444	-0,1534	1
Cluster 3							
Variable	TTCI	ICT	ITA				
TTCI	1	0,8328	0,3931				
ICT	0,8328	1	0,1444				
ITA	0,3931	0,1444	1				

Let us analyze the means of the obtained coefficients in more detail.

Thus, cluster 1, in comparison with other clusters, is characterised by the strongest direct dependence between TTCI and ITA (0.4156) and the inverse dependence between ICT and ITA (-0.1822). Besides, the countries within this cluster have almost no dependence between TTCI and ICT (-0,0763), that is, for countries of this group we reject the hypothesis 1.

The absence of multicollinearity between the TTCI and IST factors enables to construct a two-factor regression model (1):

$$\widehat{ITA}_{st} = 0,4005 \cdot TTCI_{st} - 0,1511 \cdot ICT_{st}.$$

This regression equation is statistically significant in general according to Fisher's criterion ( $F = 3.395$ , *Significance F* = 0.048). According to Student's criterion, only the influence of the TTCI factor ( $t_{a_1} = 2.37$ , *p\_level* = 0.025) is statistically significant, whereas the influence of ICT is not statistically significant ( $t_{a_2} = -0.889$ ). The coefficients of the multiple correlation ( $R = 0.442$ ), the determination ( $R^2 = 0.195$ ) and the corrected determination coefficient ( $R_{adj}^2 = 0.131$ ) indicate insufficient quality of the model. Thus, on the basis of the above stated, for the countries with the low level of tourism activity the hypothesis 2 is rejected.

Cluster 2 is characterised by a weak dependence between TTCI and ICT (0.4883), as well as between TTCI and ITA (0.3444). There is a weak inverse dependence between the ICT and ITA values (-0.1534), that is, for countries of this group we accept the hypothesis 1.

The lack of multicollinearity between the TTCI and ICT factors within the cluster 1 allows to construct a two-factor regression model (1):

$$\widehat{ITA}_{st} = 0,5506 \cdot TTCI_{st} - 0,4223 \cdot ICT_{st}.$$

This regression equation is statistically significant in terms of Fisher's criterion ( $F = 6.143$ , *Significance F* = 0.005). According to Student's criterion, the influence of both factors is statistically significant: i TPCI ( $t_{a_1} = 3.339$ ,  $p\_level = 0.002$ ), i ICT ( $t_{a_2} = -2.56$ ,  $p\_level = 0.015$ ). The coefficients of the multiple correlation ( $R = 0.504$ ), the determination ( $R^2 = 0.254$ ) and the corrected determination coefficient ( $R_{adj}^2 = 0.206$ ) indicate insufficient quality of the model. Thus, on the basis of the above stated, the hypothesis 2 for the countries with the average level of tourism activity is rejected.

Cluster 3 is characterised by a weak dependence between TPCI and ITA (0.33931), as well as by a very weak dependence between ICT and ITA (0.1444). There is a strong direct dependence between TPCI and ICT (0.8328), that is, for the countries of this group we accept the hypothesis 1.

The presence of strong multicollinearity between the factors of TPCI and ICT does not allow to construct a two-factor regression model (1).

Thus, on the basis of the aforementioned, the hypothesis 2 for the countries with the high level of tourism activity is rejected.

Let us analyze the means of the obtained coefficients in more detail.

Thus, cluster 1, in comparison with other clusters, is characterised by the strongest direct dependence between TPCI and ITA (0.4156) and the inverse dependence between ICT and ITA (-0.1822). Besides, the countries within this cluster have almost no dependence between TPCI and ICT (-0,0763), that is, for countries of this group we reject the hypothesis 1.

The absence of multicollinearity between the TPCI and IST factors enables to construct a two-factor regression model (1):

$$\widehat{ITA}_{st} = 0,4005 \cdot TTCI_{st} - 0,1511 \cdot ICT_{st}.$$

This regression equation is statistically significant in general according to Fisher's criterion ( $F = 3.395$ , *Significance F* = 0.048). According to Student's criterion, only the influence of the TPCI factor ( $t_{a_1} = 2.37$ ,  $p\_level = 0.025$ ) is statistically significant, whereas the influence of ICT is not statistically significant ( $t_{a_2} = -0.889$ ). The coefficients of the multiple correlation ( $R = 0.442$ ), the determination ( $R^2 = 0.195$ ) and the corrected determination coefficient ( $R_{adj}^2 = 0.131$ ) indicate insufficient quality of the model. Thus, on the basis of the above stated, for the countries with the low level of tourism activity the hypothesis 2 is rejected.

Cluster 2 is characterised by a weak dependence between TPCI and ICT (0.4883), as well as between TPCI and ITA (0.3444). There is a weak inverse dependence between the ICT and ITA values (-0.1534), that is, for countries of this group we accept the hypothesis 1.

The lack of multicollinearity between the TPCI and ICT factors within the cluster 1 allows to construct a two-factor regression model (1):

$$\widehat{ITA}_{st} = 0,5506 \cdot TTCI_{st} - 0,4223 \cdot ICT_{st}.$$

This regression equation is statistically significant in terms of Fisher's criterion ( $F = 6.143$ , *Significance F* = 0.005). According to Student's criterion, the influence of both factors is statistically significant: i TPCI ( $t_{a_1} = 3.339$ ,  $p\_level = 0.002$ ), i ICT

( $t_{a_2} = -2.56, p\_level = 0.015$ ). The coefficients of the multiple correlation ( $R = 0.504$ ), the determination ( $R^2 = 0.254$ ) and the corrected determination coefficient ( $R^2_{adj} = 0.206$ ) indicate insufficient quality of the model. Thus, on the basis of the above stated, the hypothesis 2 for the countries with the average level of tourism activity is rejected.

Cluster 3 is characterised by a weak dependence between TTCI and ITA (0.33931), as well as by a very weak dependence between ICT and ITA (0.1444). There is a strong direct dependence between TTCI and ICT (0.8328), that is, for the countries of this group we accept the hypothesis 1.

The presence of strong multicollinearity between the factors of TTCI and ICT does not allow to construct a two-factor regression model (1).

Thus, on the basis of the aforementioned, the hypothesis 2 for the countries with the high level of tourism activity is rejected.

## 5 Conclusion

Thus,

1) the tourist attractiveness of the country increases if there are developed information and communication technologies, because the quality of tourist information resources (including Internet resources), formation of the comfortable information environment, the mass use of platforms for travel services searching and comparing of their prices, the development of e-commerce in tourism in general contributes to the improvement of the tourism infrastructure;

2) there is no dependence of this type between tourism attractiveness and the development of information and communication technologies in the first group of countries, which is characterized by low TTCI, ICT and low intensity of tourist arrivals. There is a significant dependence in the 2nd group of countries. There is a strong direct dependence in the third group, characterised by the highest level of tourist arrivals and the highest level of tourist attractiveness. That is, the more the country is attractive for tourism, the stronger is the interdependence between the indicators of TTCI and ICT;

3) there is a weak inverse dependence between the countries' information and communication technologies development and the intensity of tourist arrivals. Moreover, this connection is not observed in any of the 3 distinct groups of countries. That is, it can be argued that the development of information and communication technologies almost does not affect the intensity of inbound tourism.

## References

1. Buhalis, D., Law R.: Progress in information technology and tourism management: 20 yearson and 10 years after the Internet – The state of eTourism research. *Tourism Management* 29, 609-623 (2008).
2. Buhalis, D.: Strategic use of information technologies in the tourism industry. *Tourism Management* 19 (5), 409–421 (1998).

3. Fodness, D., & Murray, B.: Tourist information search. *Annals of Tourism Research* 24 (3), 503-523 (1997).
4. Juan Ignacio Pulido-Fernandez, Beatriz Rodriguez-Diaz: Reinterpreting the World Economic Forum's global tourism competitiveness index. *Tourism Management Perspectives*, vol. 20, 131-140 (2016).
5. Juan Ignacio Pulido-Fernández, Pablo Juan Cárdenas-García, Juan Antonio Espinosa-Pulido: Does environmental sustainability contribute to tourism growth? An analysis at the country level. *Journal of Cleaner Production*. Vol. 213, 309-319 (2019).
6. Elisabete Paulo Morais, Carlos Rompante Cunha, João Paulo Sousa: Information and communication technologies in tourism: Challenges and trends. Conference: Proceedings of the 27th International Business Information Management Association Conference - Innovation Management and Education Excellence Vision 2020: From Regional Development Sustainability to Global Economic Growth, IBIMA. Italy. (2016) Homepage, [https://www.researchgate.net/publication/316830871\\_Information\\_and\\_communication\\_technologies\\_in\\_tourism\\_Challenges\\_and\\_trends](https://www.researchgate.net/publication/316830871_Information_and_communication_technologies_in_tourism_Challenges_and_trends).
7. Ming-Hsiang Chen: A quantile regression analysis of tourism market growth effect on the hotel industry. *International Journal of Hospitality Management*. Volume 52, 117-120 (2016).
8. Syed Abdul Rehman Khan Dong Qianli, Wei SongBo, Khalid Zaman, Yu Zhang: Travel and tourism competitiveness index: The impact of air transportation, railways transportation, travel and transport services on international inbound and outbound tourism. *Journal of Air Transport Management*, vol. 58, 125-134 (2017).
9. Sami Chaabouni: China's regional tourism efficiency: A two-stage double bootstrap data envelopment analysis. *Journal of Destination Marketing & Management*. Vol. 11, 183-191 (2019).
10. Stepchenkova, S., Mills, J. E., & Jiang, H.: Virtual travelcommunities: Self-reported experiences and satisfaction. In M. Sigala, L. Mich, & J. Murphy (Eds.). *Information and communication technologies in tourism 2007*. New York: Springer Wien. 163-174 (2007).
11. The ICT Development Index 2017 Homepage, <https://www.itu.int/net4/ITU-D/idi/2017/index.html#idi2017rank-tab>.
12. The Travel & Tourism Competitiveness Report 2017 Homepage, <https://www.weforum.org/reports/the-travel-tourism-competitiveness-report-2017>.
13. Walter Briec, Kristiaan Kerstens, Diego Prior, Ignace Van de Woestyne: Testing General and Special Färe-Primont Indices: A Proposal for Public and Private Sector Synthetic Indices of European Regional Expenditures and Tourism. *European Journal of Operational Research*. European Journal of Operational Research, Volume 271, Issue 2, 756-768 (2018).
14. Xosé Luis Fernández, Pablo Coto-Millán, Benito Díaz-Medina: The impact of tourism on airport efficiency: The Spanish case. *Utilities Policy*, Volume 55, 52-58 (2018).
15. Yang LanXue, Thomas E.Jones: Tourism-enhancing effect of World Heritage Sites: Panacea or placebo? A meta-analysis. *Annals of Tourism Research*. Vol. 75, 29-41 (2019).
16. Zheng Xiang: From digitization to the age of acceleration: On information technology and tourism. *Tourism Management Perspectives*. Volume 25, 147-150 (2018).

# Empowering Fault-Tolerant Consensus Algorithm by Economic Leverages

Igor Mazurok, Valeriy Pienko and Yevhen Leonchyk

Odessa I.I.Mechnikov National University, 2, Dvorjanskaja st., Odessa, 65082 Ukraine  
igor@mazurok.com, vpenko@onu.edu.ua, leonchyk@ukr.net

**Abstract.** This paper describes an integrated parallel fault-tolerant consensus algorithm for systems of distributed processing and storage of information with low latency. An essential characteristic of this algorithm is the integration with an economic model, ensuring its sustainable development in accordance with the goals of functioning. The proposed algorithm is called WWH (What, Where, How much), because it allows for one pass of the protocol to obtain consistent solutions on the following issues: what information will be stored; to which place of the synchronized storage it will be recorded; determination of nodes reward for fair functioning. The algorithm is based on the ideas of the SBFT algorithms, Raft and the basic principles of the Computable general equilibrium to construct the internal economy of the system functioning. The algorithm assumes resistance to two types of errors - Byzantine errors and equipment failures.

**Keywords:** consensus, fault-tolerant algorithm, tokenomics, blockchain.

## 1 Introduction

Characteristic trend of modern information systems is the transition to a decentralized architecture. In this case it is important to provide the following requirements:

- performance;
- scalability;
- tolerance to various types of attack;
- immutable and tampering safety;
- logic consistency.

Recently to support such a set of characteristics blockchain technology has been used. Due to the decentralized nature the key item of these systems is the consensus mechanism - the ability to make agreed decisions and record the corresponding results in a distributed database, which is implemented as a set of identical linear information structures (ledger). In traditional systems based on blockchain, a consensus of the Proof-of-Work (PoW) type is used (Bitcoin, Ethereum etc.). However, for many applications this type of consensus is not acceptable due to poor system performance (and/or bandwidth) and allows the system to be temporarily in an undeterministic state (branching of the blockchain - fork). There are also other types of consensus.

Some of them provide greater performance, but are vulnerable and poorly scalable (Ripple, EOS, Stellar, NEM).

The evolution of modern blockchain systems began with Bitcoin. His mythical author Satoshi Nakamoto [1] offered a mechanism that takes into account almost all aspects that determine the dynamics of this system. This ensured the stability of the system's behavior throughout the entire lifecycle. However, the Bitcoin functionality does not satisfy modern challenges. An example of a system that provides a higher degree of flexibility and variation is Ethereum. A key feature of Ethereum is the support of smart contracts, which allowed its authors to call their system World Computer. The emergence of Ethereum was the stimulus for the huge number of blockchain startups initiated by ICO. But the experience of implementing such startups has shown that the PoW mechanism used in the Ethereum does not consider the specific requirements of their functioning and development.

Other types of consensus suffer with essentially the same drawback - by providing individual key requirements, they do not allow to consider the whole set of requirements.

Solution to this problem seems to us as follows. Instead of searching for a certain consensus mechanism that would provide the full range of required system properties, we suggest using a consensus mechanism, whose architecture contains managed components that allow the main mechanism to be adapted to specific conditions. These components are integrated into the consensus protocol, providing one or another model of the economic behavior of the nodes and the system as a whole.

This methodology was tested in the implementation of the blockchain system to support the public key architecture (PKI). The consensus mechanism implemented within this system has to meet the following requirements:

- support for enterprise-scale systems, i.e. the system sets a high entry threshold for new nodes and, as a result, the number of network nodes is limited to several hundred;
- the system must provide a high response rate to the client request;
- processing nodes of the system are functionally equal, ensuring its decentralization;
- reliability of operation, consisting in resistance to Byzantine threats and the fork occurrences;
- transactions in the system are processed separately, not combined into blocks that reduces the guaranteed transaction processing time due to high overall system performance (there is no common transaction pool).

The relevance of the presented work is justified by the necessity to overcome the limitations associated with the popular types of consensus PoW and PoS during modern decentralized systems development.

## **2 Related Works**

Listed above features make us seek a suitable consensus algorithm in a more general context of distributed computing systems. In this sense, the Paxos [2] algorithm is the

most discussed in academic publications. However, attempts to use it in real systems cause difficulties. To avoid them, various modifications of this algorithm have been proposed. In particular, Raft [3] was designed to support modularity, which in turn led to its clarity and ease of implementation. It contains sufficient tools to support a ledger and is focused on the use of the leader node and provides only CFT. However, considering the above requirements, this is not enough, since Byzantine threats may arise in the system. There is known modifications of the Raft algorithm that overcome this limitation [4, 5]. Some features of these modifications were used in this paper. However, the known modifications lack incentivization for fair nodes. This incentivization is often implemented as a separated subsystem. There are some attempts to inject adequate economic mechanism into consensus algorithms (e.g. [6]) but they still have no enough adjustability to certain economical model. But we offer to integrate economic logic into the consensus mechanism.

### 3 Consensus with integrated economic

As mentioned above, the main mechanism to obtain the required properties of decentralized system is to integrate into the consensus logic a model of economic behavior which provides necessary adjustment of the system dynamics. This model is usually called tokenomics, since it is based on the use of tokens - specialized cryptocurrency.

The system functions by transmitting and processing asynchronous messages between peer-to-peer network nodes. In effective tokenomics it is important to distinguish between the roles of nodes during their intercommunications:

- a regular node that signs and stores certificates;
- a receiving node that receives a certificate signing request (CSR) from a client, it also receives payment from the client and rewards the nodes;
- a leader node that coordinates messaging between other nodes.

To find the optimal parameters for the system functioning we define a model containing information about history of actions performed by the participants of the system.

Such a model can naturally be defined in form of an oriented weighted graph, whose nodes are the nodes of the system (or rather their participation in a certain stage of network communication), communications — messages or requests marked with information accompanying such communications.

The route in this graph describes the sequence of steps in the communication protocol, which leads to the achievement of the result. At this point, you can determine the share of the participant's rewards based on his participation in the protocol. All information necessary for such calculations is recorded in the blockchain of the system together with a certificate.

The tokenomics of the entire system functions as a cyclic process, each stage of which consists of the following steps:

- 1) When a CSR appears, each node  $i$  makes a bet, ensuring its honest and reliable functioning. The sum of these rates  $s$  and client certificate payment  $S_{cert}$  form the total budget of the certificate:



$$B_{CSR} = S_{cert} + \sum_i s_i$$

- 2) Nodes perform consensus protocol;
- 3) The budget of each certificate is distributed in accordance with the share of each node participation and its rate. As a result, the node reward is lost (reduced) if the node is an attacker or has failed (crashed).

At the moment we offer the following models of the participant's bid value:

- 1) Free Fixed Stake Model: All nodes can either play at a fixed rate  $\sigma$  or not play at all;
- 2) Free Gambling Stake Model: A model that allows you to choose bets in a certain range  $[\alpha; \beta]$ , or not to play at all;
- 3) Force Fixed Stake Model: Participants play only at a fixed rate  $\sigma$ ;
- 4) Force Gambling Stake Model: A model that obliges to play, however, allows you to independently determine the value of the bet in the range  $[\alpha; \beta]$ .

The system must accept one of these models for all participants. Given the above notation the differences between models can be represented by the following Table 1.

**Table 2.** Stake differences between models.

	<b>Free Stake</b>	<b>Force Stake</b>
Fixed Model	$s_i \in \{0, \sigma\}$	$s_i = \sigma$
Gambling Model	$s_i \in \{0\} \cup [\alpha; \beta]$	$s_i \in [\alpha; \beta]$

A comparison of these models allows us to make some preliminary conclusions about the results of their use. Forced rates make it economically unprofitable node downtime. This is important for the consensus using the majority principle. Gambling Model allows you to enter the concept of the node reputation into functioning of the system, which means the degree of its reliable operation. Trusted nodes can afford to bet larger. Thus, the option Force Stake Gambling Model is more adaptive to use in environmental conditions with possible equipment failures and communication protocol algorithms.

The optimal model of tokenomics should provide an economic motivation for the correct execution of all processes implemented by the system: extract the certificate, write to the ledger and maintain its integrity.

For a detailed description of the tokenomics parameters, we describe the communication protocols used in the system.

### 3.1 The Protocol for Issuing a Certificate Including the Node's Contribution

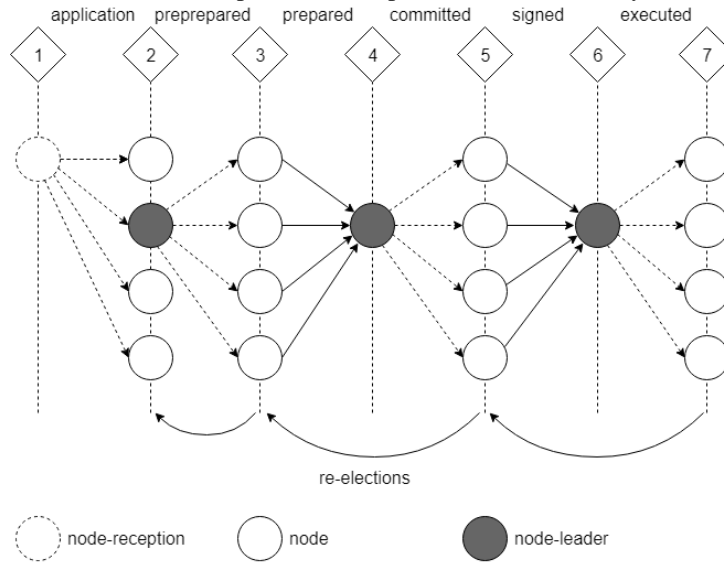
Next, the certificate issuance protocol derived from the SBFT algorithm [5] will be described. All node's messages transmit information in a cryptographically signed form in order to avoid its distortion during the transmission by the communication channel.

In order to provide sustainable functionality, the system has to satisfy the next requirement: the total node number  $n$  must be greater than  $2f+c$  where

- $f$  - the maximum number of faulty (byzantine) nodes;
- $c$  - the maximum number of crashed nodes (at least within established period of time).

At each step, one of the nodes plays the role of a leader. Its main task is to relay messages received from ordinary nodes. At every communication stage the current *leader* gets not less than  $2f+1$  uncorrupted messages with no more than  $f$  faulty messages among them. Thus, there are always at least  $f+1$  identical messages which is sufficient for the majority of considerations.

The protocol has several steps and can be presented schematically (see Fig. 1).



**Fig. 1.** The certificate issuance protocol.

At each step, the nodes send messages to each other with the following unified structure: From-Message-To. Below is a description of the actions at each step. Step is a transition from one state to another, for example, the transition from the first state to the second one is indicated by 1-2.

1-2) *node-reception* sends to all nodes the *applicationRequest* message (a request to receive a certificate with proposed payment Scert) with following content:

**From:** *node-reception*    **To:** *all nodes*    **Message:** *PK\_applicant, Payment*  
 where *PK\_applicant* is a client public key, *Payment* is amount of tokens. This message may have some additional data. All nodes record source and time of receiving the request.

Possible attack: Availability of payment information prevents spam-sending unpaid requests.

2-3) After receiving the *applicationRequest* message, current *leader* checks *Payment* and sends the following *prepreparedRequest* message to all *nodes*:

**From:** *node-leader*    **To:** *all nodes*

**Message:** *node-reception, PK\_applicant, Payment, FFLN, t\_leader, Lid, VD*

where *FFLN* is the first free number in the ledger of the current node-leader that was not previously reserved. Thus, a new certificate will be added to the end of the ledger. The node leader also transmits *t\_leader* — the term number (used to select a leader for re-election) and *Lid* — leader's identifier.

At this step, the node-leader may initiate a selective check of the the ledger block relevance. To do this, a *VD* field (verification data) is added to the *prepreparedRequest* message, containing a request for some data from the ledger blocks.

If the node-leader did not perform its functions - did not send a message within a predetermined time (time-out) at this step or sent an incorrect message - the node initiates re-election. Re-election starts when a sufficient number of nodes initiate re-election (the re-election procedure is described below). An example of an invalid message is the *prepreparedRequest* message, in which the public key does not match the public key in the initial node-reception request.

Possible attack: To compromise a node-leader, a node-reception can send a different message to it. To eliminate this, the node-leader additionally sends a message which it received from node-reception to the other nodes. All the nodes in this step verify this message with one they received directly from the node-reception and, in case of any discrepancies, ignore this request, terminating the certificate issuance protocol.

3-4) Each node sends the *preparedRequest* message to the current node-leader:

**From:** *node* **To:** *node-leader* **Message:** *preparedRequest, Lid, Nid*  
*Nid* is the node number that generated this message.

As soon as the node-leader received the first  $2f+1$  *preparedRequest* messages, the transition to the next step takes place.

4-5) Node-leader passing  $2f+1$  message in the *committedRequest* message as an array.

**From:** *node-leader* **To:** *all nodes* **Message:** *preparedRequest[2f+1]*

Each node performs a validation of the node-leader term, i.e. *t\_leader* is not less than its node term. Also, the *FFLN* relevance check is performed, providing the entry into the longest ledger.

Any violation leads to the initiation of a re-election of the leader by the node, and if a sufficiently large number of such failures are accumulated, this will lead to the re-election of the node-leader.

Further according to the majority rule node prepares the following information for inclusion in the message: *node-reception, PK\_applicant, Payment, FFLN, Lid*. The majority rule says that the value of the field is included in the message if it is encountered no less than in the  $f+1$  elements of the *committedRequest* message array (the message of the node itself is also taken into account).

Accumulated to this point in the communication messages information allows you to determine which nodes acted efficiently and correctly in step 3-4. This information is analyzed and recorded as a binary vector, *Participation\_1*, in which the *i*-th element

is 1 if the node was among the first  $2f+1$  nodes that sent the *preparedRequest* message, and its value coincided with most similar messages from other nodes.

5-6) Next, each node sends the following message to the signedRequest:

**From:** *node* **To:** *node-leader*

**Message:** *node-reception, PK\_applicant, Payment, FFLN, Nid, Lid, Cid, Participation\_1, VDR*

*Nid* is the identifier of the node that formed this message, *Cid* is the identifier of the node from which the *committedRequest* is received (*Cid* may differ from *Lid* if re-election occurred at the previous stage), *VDR* is the information sent in response to the *VD* request.

6-7) Node-leader accumulates  $2f + 1$  *signedRequest* message and sends them in the message *executedRequest* in the form of an array.

**From:** *node-leader* **To:** *all nodes* **Message:** *signedRequest[2f+1]*

Information accumulated in the *signedRequest* array makes it possible to evaluate the participation of nodes in step 5-6 (in addition to the vector *Participation\_1*) and honest storage behavior of the ladder (comparison of *VD* and *VDR*). This information is fixed in the form of two binary vectors *Participation\_2* and *DataSaving*, similarly to the vector *Participation\_1*.

Information provided in these three vectors, as well as data on the participation of nodes as leaders, is sufficient to calculate the remuneration of all participants.

If there are  $f+1$  identical records in the message, their content is considered authentic and is written to the ledger by all nodes, and the reception-node sends the signed certificate to the Client.

Here, as well as at the end of steps 2-3 and 4-5, node-leader re-election is possible.

Since unfair storage of ledger is not economically justified, the nodes are interested in updating its status. For this, any node based on *FFLN* or *VD* (*VDR*) can request the node-leader for all previous blocks, starting with a certain number, or for missing certificates to update its ledger.

Possible attack: Malicious nodes can intensively send a ledger repair requests to the leader. To prevent collapse in this case, you can pay an additional fee for servicing such requests.

### 3.2 Fault Tolerant Election Protocol

As mentioned above, a specially chosen node-leader plays an important role. The need for re-election arises if a node for a sufficiently long time does not receive messages from the current node-leader or if it receives a message with violated cryptographic integrity. The election of a new node-leader is a multi-step messaging process with the robustness feature.

### 3.3 Rewards calculation

Upon successful completion of the protocol, all nodes have information about the number of messages from each other with confirmed accuracy. Node messages are considered reliable if they fall into the final majority vector. Current node-leader mes-

sages are considered confirmed if the node's response message is valid. To define rewards participant's contributions have to be counted:

1. The contribution of term node-leader for reaching a consensus -from  $f$  to  $n$  and for replicating the ledger from 0 to  $n-f$ ;

2. The contribution of the ordinary node for reaching a consensus from 0 to 2 and for replication and storage – 0 or 1.

At different terms node  $i$  can play different roles and its total contribution  $C_i$  is summed over all terms. The weighted share of  $P_i$ 's reward, taking into account the  $s_i$  rate for the Gambling Model, is:

$$P_i = \frac{C_i s_i}{\sum_i C_i s_i}$$

Thus, the node reward is determined by the formula:  $R_i=[B_{CSR}, P_i]$ , where square brackets denote banking rounding.

## 4 Conclusions

Presented algorithm allows the participants (nodes) of the decentralized system to come to a common opinion (consensus) on the contribution of each other directly during consensus execution and does not require additional nodes that control the process. In particular, the proposed approach was implemented within a decentralized system supporting PKI and allowed to consider requirements of both consistency and needed economic features.

The method of rewarding nodes described above is one of the possible options and depends on the specific type of tasks and goals of the functioning of the system. The search for optimal parameters of tokenomics for effective work is an open question. Due to the fact that these parameters in the proposed scheme are expressed in the protocol messages, it is possible to build a multi-factor simulation model to achieve the optimal configuration.

## References

1. Nakamoto, S.: Bitcoin: A Peer-to-Peer Electronic Cash System (2009). <https://bitcoin.org/bitcoin.pdf>.
2. Lamport, L.: The Part-Time Parliament. *ACM Transactions on Computer Systems*. 16 (2): 133–169 (1998).
3. Ongaro, D., Ousterhout, J.: In Search of an Understandable Consensus Algorithm (2014). *USENIX Annual Technical Conference*. <https://ramcloud.stanford.edu/wiki/download/attachments/11370504/raft.pdf>
4. Wang D., Tai, N., An, Y.: Byzantine Fault Tolerant Raft. Stanford Computer Science Department (2018). [http://www.scs.stanford.edu/17au-cs244b/labs/projects/wang\\_tai\\_an.pdf](http://www.scs.stanford.edu/17au-cs244b/labs/projects/wang_tai_an.pdf)
5. Gueta G.G., Abraham I., Grossman S., Malkhi D. et al.: SBFT: a scalable decentralized trust infrastructure for blockchains (2018). <https://arxiv.org/abs/1804.01626>
6. Amoussou-Guenou, Y., Del Pozzo, A. et al.: Correctness and Fairness of Tendermint-core Blockchains. *IACR Cryptology ePrint Archive* (2018). <https://arxiv.org/abs/1805.08429>

# Government Financial Support of Higher Education and its Role in Economic Prosperity of a Society

Marina Bilinets<sup>1</sup> [0000-0001-5816-0080], Lidiia Hladchenko<sup>2</sup> [0000-0003-1533-3505], and Tetiana Paientko<sup>3</sup> [0000-0002-2962-308X]

<sup>1</sup> Kyiv National Economic University named after Vadym Hetman, 54/1, Peremohy Ave., Kyiv, 03680, Ukraine

marina.bilinets@icloud.com

<sup>2</sup> Kyiv National Economic University named after Vadym Hetman, 54/1, Peremohy Ave., Kyiv, 03680, Ukraine

l\_gladchenko@kneu.edu.ua

<sup>3</sup> Kyiv National Economic University named after Vadym Hetman, 54/1, Peremohy Ave., Kyiv, 03680, Ukraine

tpayentko109@gmail.com

**Abstract.** This study focuses on the role of government higher education funding in building the economic capacity of national economy. Contemporary development and competitiveness of any country crucially depends on innovations. The ability of business to provide them is directly connected with available human capital resources. Government financial support of education ensures human capital development. Government budget funding of education is one of the biggest sources of higher education funding, and thus influences economic prosperity fostering GDP per capita growth. The article purpose is to examine government higher education expenditures impact on GDP per capita growth. The research methodology uses panel data analysis based on R statistics. The data sources are the World Bank and OECD. Literature review reveals methods of education funding and the role of government. Then, five hypotheses are posited that describe possible impact of government education funding on GDP per capita growth. To test them, four models are used. The appropriate model to reveal the government higher education funding role is the fixed-effect model. It validates the strong impact of the share of higher education expenditures in the total government expenditures on the GDP per capita growth.

**Keywords:** Higher Education, Government Education Expenditures, Economic Growth, GDP per capita.

## 1 Introduction

Education is one of the key factors of a country success in the global world. Educational level of the population, the quality of education and access to education services lay the groundwork for economic development and determine institutional vectors for sustainable development. Governments of high-income countries make substantial investments in the development of education and foster favorable environ-

ment for private investments in educational sector. At the same time, expenditures on education funded by using money of taxpayers cause vast discussions. Some considerations concern problems of redistributions when taxpayers do not want to pay for services which they do not use. Other discussions are induced by the problems of proper quality of education even under high level of government expenditures in this sector.

Successful development of a country depends on many factors. The educational level of the population plays one of the leading roles in the prosperity of a society. Access to the primary education creates a requisite for further tuition. At the same time, the quality and accessibility of higher education, especially in science and technology, affects a country's development capacity in economic, innovation and other aspects. That is why this research is focused on the assessment of impact of higher education funding on the national economies development.

The research aim is to assess the impact of higher education funding through taxpayers' money on the level of economic development. The structure of the study includes:

- literature review on the issues of education funding in the world;
- research methodology;
- the assessment of government higher education expenditures impact on the level of economic development (GDP per capita growth);
- conclusions.

Based on data analytics, this paper uncovers dependency of economic development on government higher education expenditures. The obtained results demonstrate that the most appropriate model to reveal the government higher education funding role is the fixed-effect model. This model shows the strong positive impact of the share of higher education expenditures in the total government expenditures on the GDP per capita growth. At the same time, education expenditures measured as GDP share reveals negative dependence. This issue can be explained, on the one hand, by research limitations of this paper, and on the other hand, by other factors, among which differences in the rates of GDP growth and growth of governments higher education funding, natural limits of education expenses, and existence of vast range of factors influencing GDP per capita.

The paper has several limitations. First of all, the sample includes mainly high and medium-income countries. Secondly, the time horizon of panel data covers period of 2006-2015 that is caused by absence of all necessary data. At the same time, government education expenditures demonstrate predominantly long-term effects that can be more clearly observed through the period of 10-20 years or more. Thirdly, the paper examines only the government expenditures on education and their influence on economic development, while other expenses are beyond this study. At last, the research analyzes economic development expressed as GDP per capita growth while doing business index, innovation index, human development index, life expectancy and other indicators of economic development are beyond the study.

## 2 Literature Review

Public funding of education is justified by the craving for equitable access to education for all people. According to Douglass, policy in education funding doesn't concern taxpayers' income redistribution only; it also involves issues of social and economic mobility, economic competence, money, policy and big business (Douglass, J.A. [7])

The structure of education funding in the USA and Western European countries depends on the level of education. Obviously, the basic level of education generates the biggest utility for a society as it forms a requisite for all competencies development and other levels of tuition. In the case of schools, public expenditures prevail over the private funding because a government determines and guarantees the basic level of education necessary for society development. On the other hand, competencies enhancing economic development are ensured predominantly by vocational and higher education (Friedman [17]). Nowadays, the role of public finance in funding the vocational and higher education is diminishing. This trend is caused mostly by austerity policy, budget deficit and high levels of public debt.

Public mood also influences government education expenditures. The public opinion research by Busemeyer, Marius R. Garritzmann, Julian L. Neimanns, Erik Nezi [4] proves that people favor government education subsidies. Meanwhile, not all the sectors demonstrate equally high level of people support: higher basic (elementary) and vocational education expenditures are more preferable than increasing expenditures on higher and preschool education.

There are different methods for education funding. According to them, all the countries can be divided into three groups (European Commission/EACEA/Eurydice [9]):

1. Formula-based funding that applies generally accepted standards and criteria for determining the amount of funding for every institution. In the beginning of 2000-s, only 13 European countries applied formula-based funding (Levacic, R. [11]). Nowadays, this method is widely used especially due to the World Bank activity (Alonso, Juan Diego and Alonso Sánchez [1]). The formulas use indicators that can be divided into several groups (Mihály Fazekas [14]): (1) basic indicator – number of students and graduates according to the levels; (2) indicators of needs; (3) indicators as reported by training and educational plans; (4) indicators based on characteristics of educational institution.
2. Funding based on the agreed budget supposes that an educational institution prepares budget, and a public authority should approve it (C. Jencks, J. Areen [15]).
3. Discretionary approval of funding by an authority, the volume of which is determined individually or on a contractual basis.

The study of reforms in higher education funding in different countries in Europe, Asia and America revealed the key trends (Nagy Kováts, Németh [16]):

1. Diversification of higher education funding. This process should contribute to the higher efficiency of budget resources disposal.



2. Transformation of mechanisms for public funding of higher educational institutions. In order to increase universities' sensitivity to the demand and needs of customers, governments transfer part of the funds to the households or business in the form of subsidized loans or tax allowances [2], [3], [5].

Furthermore, changes in mechanisms of direct public funding are observed: (i) education budget is divided into two separate directions – funding of education and research activities; (ii) almost all countries use formula-based approach to the education funding; (iii) universities funding depends on the performance indicators; (iv) budget assignments are based on block-grants that foster universities autonomy especially strengthening on issues of public funding distribution.

At the same time, alternative sources of education funding are ambiguous; they cause discussions and searching for evidence of their effectiveness [6], [10], [17]. Performance-contracts are becoming more and more popular as one of the methods for education funding especially for higher educational institutions (Lung M., Moldovan I., Nistor Lung A. [12]). Their advantages are connected with the possibility of determining indicators and goals based on the sectoral strategic goals that should be reached by universities. This practice allows governments to influence universities' activities.

Share of public funding of education, provided on the performance-contracts based, differs between countries. However, most governments have embedded this practice into the education funding scheme. The unified set of indicators for contracts is absent. The same is true for the contracts maturity that varies from 1 to 5 years among countries. European countries usually apply such indicators as students' performance indicators, academic mobility, graduate employment rate, place of a university in the ranking, quality of university infrastructure, and other.

The study of public funding of education (Marginean I. [13]) focused on government education expenditures per capita and as GDP share. The analysis of public expenditures impact on education took into account social indicators such as education coverage according to the elementary, secondary and higher education; young people with full secondary education, and children that drop out school. The research results demonstrated substantial differences both between countries and levels of education. At the same time, the study revealed that there is a dependence between public expenditures on education and analyzed indicators for elementary and secondary education only. This is caused by the government policy in this sector: elementary and secondary education are usually funded by government budget unlike higher education where expenditures are usually considered as human capital investments.

### **3 Methodology**

The study hypothesizes that increasing government expenditures on higher education has a positive effect on the dynamics of GDP per capita. The analysis was carried out using R software. Four models were used for the analysis: pooling, random, within, and between. Data for analysis are available from World Bank and OECD data bases on tertiary educations expenditures. Data were organized as a panel data. The

panel consists of indicators for twenty-seven countries for time horizon 2006-2015. The study includes mainly high and medium-income countries. Countries included into panel are Australia; Austria; Azerbaijan; Belarus; Brazil; Colombia; Czech Republic; Denmark; Estonia; Finland; France; Germany; Hong Kong SAR, China; Hungary; Ireland; Japan; Latvia; Lithuania; Norway; Poland; Portugal; Slovak Republic; Spain; Sweden; Switzerland; Ukraine; United Kingdom. The total number of observations amounts to 262.

Five hypotheses were posited:

- Hypothesis 1: increasing share of education expenditures in the total government expenditures positively affects growth of GDP per capita;
- Hypothesis 2: increasing share of higher education expenditures in the total government expenditures positively affects growth of GDP per capita;
- Hypothesis 3: increasing share of higher education expenditures in the total education expenditures positively affects growth of GDP per capita;
- Hypothesis 4: increasing share of education expenditures in GDP positively affects growth of GDP per capita;
- Hypothesis 5: increasing share of higher education expenditures in GDP positively affects growth of GDP per capita.

## 4 Results

The first stage of analysis determined GDP per capita growth (GDPGROWTH) as a dependent variable; while independent variables included:

1. the share of education expenditures in the total government expenditures, % (EEINTOTALGOVEXP);
2. the share of higher education expenditures in the total government expenditures, % (HEINTOTALGOVEXP);
3. the share of higher education expenditures in the total education expenditures, % (HEINTOTALGOVEXPEDUC);
4. the share of education expenditures in GDP, % (GOVERNEXPEDUCINGDP);
5. the share of higher education expenditures in GDP, % (GOVENEXPHEINGDP).

The results of statistical analysis are presented in Table 1.

**Table 1.** The Hypotheses Testing Results

Residuals:				
Min.	1st Qu.	Median	3rd Qu.	Max.
-15.032009	-1.871411	0.028507	2.087064	20.270745
Coefficients:				
	Estimate	Std. Error	t-value	Pr(> t )
(Intercept)	7.86965	4.61141	1.7066	0.0891163
EEINTOTALGOVEXP	1.35033	0.35819	3.7698	0.0002029 ***
HEINTOTALCOVEXP	-3.86866	1.27219	-3.0409	0.0026033 **

HEINTOTALGOVEXPEDUC	-0.14419	0.20896	-0.6900	0.4907911
GOVERNEXPEDUCINGDP	-4.49925	1.06688	-4.2172	3.434e-05 ***
GOVENEXPHEINGDP	12.17901	3.90780	3.1166	0.0020382 **
Signif. codes: 0 '***' 0.001 '**' 0.01 '*' 0.05 '.' 0.1 ' ' 1				

Source: calculated by authors based on the World Bank and OECD data

The obtained results demonstrate that the most significant impact on GDP per capita growth has:

- the share of education expenditures in the total government expenditures;
- the share of education expenditures in GDP.

Lower level of impact on GDP per capita growth produces another two factors:

- the share of higher education expenditures in the total government expenditures;
- the share of higher education expenditures in GDP.

Analysis evidences that the share of higher education expenditures in the total education expenditures does not influence the GDP per capita growth. The reason of it can be the diversification of universities funding resources that diminishes the significance of government influence.

Panel is not balanced because data on Azerbaijan, Belarus, Columbia and Hong Kong are not available for some years. For more reliable results, models with fixed effects, random effects and between were built. The fixed-effect model is an ordinary model of linear regression in which the free terms vary by economic units  $i$ . In this model, the standard assumptions are the same as in the ordinary linear regression:

Assumption 1. Zit factors are independent of  $\epsilon_{it}$  for all  $i$  and  $t$ .

Assumption 2. Errors  $\epsilon_{it}$  are independent and equally distributed quantities,  $E(\epsilon_{it})=0$ ,  $E(\epsilon_{it}^2) = \sigma^2$  for all  $i$  and  $t$ .

The fixed-effect model should be used in the case when every economic unit is "special", and is not a result of a random selection from a general population.

Table 2 presents the obtained results of above mentioned models.

**Table 2.** The Testing Results for Models with Fixed Effects, Random Effects and Between

	Dependent variable:			
	GDPGROWTH			
	(polled)	(random)	(fixed)	(between)
EEINTOTALGOVEXP	1.4*** (0.4)	1.4*** (0.4)	2.0*** (0.5)	0.7 (0.5)
HEINTOTALCOVEXP	-3.9*** (1.3)	-3.9*** (1.3)	-1.8 (1.7)	-1.9 (1.9)
HEINTOTALGOVEXPEDUC	-0.1 (0.2)	-0.1 (0.2)	-0.1 (0.4)	-0.2 (0.2)
GOVERNEXPEDUCINGDP	-4.5*** (1.1)	-4.5*** (1.1)	-5.9*** (1.8)	-2.7*** (1.4)
GOVENEXPHEINGDP	12.2*** (3.9)	12.2*** (3.9)	4.5 (7.6)	7.3 (4.9)
Constant	7.9* (1.1)	7.9* (1.1)		8.0 (1.1)

	(4.6)	(4.6)		(4.9)
Observations	262	262	262	27
R2	0.1	0.1	0.2	0.4
Adjusted R2	0.1	0.1	0.1	0.3
F Statistic	7.9*** (df = 5; 256)	39.4***	11.4*** (df = 5; 230)	2.9** (df = 5; 21)
Note: *p<0.1; **p<0.05; ***p<0.01				

Source: calculated by authors based on the World Bank and OECD data

The testing of the models significance demonstrates:

1. F-statistic: 2.9071 on 5 and 21 DF, p-value: 0.037925

> pFtest(m.fe, m.pooled)

2. F test for individual effects

data: GDPGROWTH ~ EEINTOTALGOVEXP + YEINTOTALGOVEXP + YEINTOTALGOVEXPEDUC + ...

F = 1.8684, df1 = 26, df2 = 230, p-value = 0.008412

alternative hypothesis: significant effects

> phtest(m.fe, m.re)

3. Hausman Test

data: GDPGROWTH ~ EEINTOTALGOVEXP + HEINTOTALGOVEXP + HEINTOTALGOVEXPEDUC + ...

chisq = 28.124, df = 5, p-value = 3.443e-05

alternative hypothesis: one model is inconsistent

> plmtest(m.re, type = "bp")

4. Lagrange Multiplier Test - (Breusch-Pagan) for unbalanced panels

data: GDPGROWTH ~ EEINTOTALGOVEXP + HEINTOTALGOVEXP + HEINTOTALGOVEXPEDUC + ...

chisq = 0.24092, df = 1, p-value = 0.6235

alternative hypothesis: significant effects

5. F test

data: GDPGROWTH ~ EEINTOTALGOVEXP + HEINTOTALGOVEXP + HEINTOTALGOVEXPEDUC + ...

F = 11.353, df1 = 5, df2 = 230, p-value = 8.411e-10

> pwaldtest(m.re, test = "Chisq")

6. Wald test

data: GDPGROWTH ~ EEINTOTALGOVEXP + HEINTOTALGOVEXP + HEINTOTALGOVEXPEDUC + ...

Chisq = 39.368, df = 5, p-value = 2.002e-07

The values of determination coefficients are low. In other words, the model describes the studied dependency poorly. However, even under the low coefficient of determination, it is obvious that the third factor (the share of higher education expenditures in the total education expenditures) doesn't influence the tested variable – GDP per capita growth. It means that the third hypothesis is not confirmed.

The obtained results caused the next step. To balance the database, indicators for Azerbaijan, Belarus, Columbia and Hong Kong were excluded. At the same time, five

dummy indicators were included to the model. Table 3 presents the results of regression analysis.

**Table 3.** The Testing Results of the Model Based on the Balanced Database

Dependent variable:				
	GDPGROWTH			
	(polled)	(random)	(fixed)	(between)
EEINTOTALGOVEXP	1.1 (0.7)	1.1 (0.7)	0.2 (0.8)	2.3* (1.1)
HEINTOTALCOVEXP	-2.0 (2.9)	-2.0 (2.9)	7.5** (3.5)	-8.9* (4.7)
HEINTOTALGOVEXPEDUC	0.3 (0.4)	0.3 (0.4)	-0.1 (0.5)	1.5** (0.5)
GOVERNEXPEDUCINGDP	-1.9 (1.8)	-1.9 (1.8)	-2.3 (2.1)	1.1 (2.7)
GOVENEXPHEINGDP	0.7 (6.9)	0.7 (6.9)	-14.2 (9.2)	-6.3 (10.3)
DUMMY1	0.6 (0.9)	0.6 (0.9)	4.0 (6.0)	0.01 (0.8)
DUMMY2	1.3 (0.9)	1.3 (0.9)	7.0 (5.5)	0.3 (0.8)
DUMMY3	1.4 (0.9)	1.4 (0.9)	1.9 (3.7)	1.9** (0.8)
DUMMY4	1.4 (0.9)	1.4 (0.9)	-2.1 (2.5)	1.9** (0.8)
Constant	-4.9 (9.9)	-4.9 (9.9)		-35.3** (12.9)
Observations	230	230	230	23
R2	0.1	0.1	0.2	0.6
Adjusted R2	0.1	0.1	0.1	0.4
F Statistic	3.5*** (df = 9; 220)	31.3***	6.9*** (df = 9; 198)	2.4* (df = 9; 13)

Note: \*p<0.1; \*\*p<0.05; \*\*\*p<0.0

Source: calculated be authors based on the World Bank and OECD data

The results of models significance testing are the following:

1. F test for individual effects

data: GDPGROWTH ~ EEINTOTALGOVEXP + HEINTOTALGOVEXP + HEINTOTALGOVEXPEDUC + ...

F = 2.4167, df1 = 22, df2 = 198, p-value = 0.0007056

alternative hypothesis: significant effects

> phtest(m.fe, m.re)

2. Hausman Test

data: GDPGROWTH ~ EEINTOTALGOVEXP + HEINTOTALGOVEXP + HEINTOTALGOVEXPEDUC + ...

chisq = 46.784, df = 9, p-value = 4.306e-07

alternative hypothesis: one model is inconsistent

3. F test

data: GDPGROWTH ~ EEINTOTALGOVEXP + HEINTOTALGOVEXP + HEINTOTALGOVEXPEDUC + ...

F = 6.9449, df1 = 9, df2 = 198, p-value = 1.089e-08

> pwaldtest(m.re, test = "Chisq")

4. Wald test

data: GDPGROWTH ~ EEINTOTALGOVEXP + HEINTOTALGOVEXP + HEINTOTALGOVEXPEDUC + ...

Chisq = 31.315, df = 9, p-value = 0.0002613

After the application of dummy variables, the calculation revealed the increased value of the determination coefficient for the between model. Hausman Test demonstrates that the use of random-effect model is inappropriate. Moreover, Table 3 shows that the first factor (the share of education expenditures in the total government expenditures) doesn't have a significant impact on the examined indicator. It means that the first factor is not confirmed.

The obtained outcomes require the model correction: the share of higher education expenditures in the total education expenditures is excluded, because it has strong correlation with the first factor. The regression statistics results are presented in Table 4

**Table 4.** The Regression Statistics Results for the Finally Corrected Database

Results Description			
	Dependent variable:		
	GDPGROWTH		
	(Pooling)	(Fixed)	(Between)
EEINTOTALGOVEXP	0.8	-0.9	0.2
	(0.6)	(0.5)	(0.7)
HEINTOTALCOVEXP	-0.8	11.5***	7.1**
	(2.5)	(2.6)	(3.0)
GOVERNEXPEDUCINGDP	-2.7*	-2.0	-2.0
	(1.5)	(1.2)	(1.6)
GOVENEXPHEINGDP	3.7	-22.3***	-15.4**
	(5.7)	(5.9)	(7.1)
DUMMY1	0.7	2.5	4.1
	(0.9)	(9.0)	(6.0)
DUMMY2	1.4	1.9	7.0
	(0.9)	(7.7)	(5.5)
DUMMY3	1.3	-2.5	2.0
	(0.9)	(6.3)	(3.7)
DUMMY4	1.3	-3.7	-2.1
	(0.9)	(4.4)	(2.5)
Constant	2.6	-0.04	
	(2.0)	(0.3)	
Observations	230	207	230
R2	0.1	0.2	0.2

Adjusted R2	0.1	0.2	0.1
F Statistic	3.8*** (df = 8; 221)	7.5*** (df = 8; 198)	7.8*** (df = 8; 199)
Note: *p<0.1; **p<0.05; ***p<0.01			

Source: calculated by authors based on the World Bank and OECD data

The obtained results reveals that the most appropriate is the fixed-effect model. For the examined sample, this is a consistent outcome because economic units (countries) are examined by the same groups of indicators and time intervals. The calculations witness that the biggest influence on per capita GDP growth has:

- the share of higher education expenditures in the total government expenditures (positive impact equals +11.5);
- the share of education expenditures in GDP (negative impact equals -22.3).

In this way, the second hypothesis (increasing share of education expenditures in GDP positively affects growth of GDP per capita) is confirmed, and the fifth hypothesis (increasing share of higher education expenditures in GDP positively affects growth of GDP per capita) is not.

These opposite impacts can be explained by several factors. First of all, this paper has research limitations connected with countries data available and time horizon. Secondly, GDP per capita and government education funding can demonstrate different growth rates. Thirdly, total education expenses in national economy are not limited by the government funding. This fact puts limits on government impact on GDP growth. Furthermore, education expenses have their natural limits at a certain period of time. Finally, government education expenditures are just one of the numerous factors influencing GDP per capita growth. Thus, these study results form basis for further research.

## 5 Conclusions

All the countries have national specifics in funding education. Literature review showed that governments use mixed sources and various mechanisms to fund education. Government funding of education should ensure, among others, equitable access to the education services for all people. Budget expenditures have different share in the total amount of education expenses depending on the type of education (basic, vocational or higher) and national practice.

Governments use various methods for education funding: formula-based funding; funding based on the agreed budget; discretionary approval of funding; educational vouchers and others. The latest European tendencies proves the quick spreading of formula-based approach in universities funding.

Higher education funding in the world demonstrates several common tendencies:

- diversification of funding sources;

- transformation of government support: governments more and more use subsidized loans and tax allowances for individuals and business to induce higher sensitivity of universities to the customers' demand;
- applying the formula-based education funding;
- funding according to the university performance indicators (so called performance contracts);
- disposal of block-grants in higher education funding.

Funding of education concerns not only quality and access to the education services or income redistribution issues, but also labor resources, business environment, innovations, and sustainable development. To examine the influence of higher education expenditures on GDP per capita growth, the study posed 5 hypotheses: (1) increasing share of education expenditures in the total government expenditures positively affects growth of GDP per capita; (2) increasing share of higher education expenditures in the total government expenditures positively affects growth of GDP per capita; (3) increasing share of higher education expenditures in the total education expenditures positively affects growth of GDP per capita; (4) increasing share of education expenditures in GDP positively affects growth of GDP per capita; (5) increasing share of higher education expenditures in GDP positively affects growth of GDP per capita.

To obtain reliable results, models with fixed effects, random effects and between were used. The most appropriate model to reveal the role of government higher education funding proved to be the fixed-effect model. The fixed-effect model shows the strong positive impact of the share of higher education expenditures in the total government expenditures on the GDP per capita growth. At the same time, education expenditures measured as GDP share reveals negative dependence. This issue can be explained, on the one hand, by research limitations of this paper, and on the other hand, by other factors, among which differences in the rates of GDP growth and growth of governments higher education funding, natural limits of education expenses at a certain period of time, and existence of vast range of factors influencing GDP per capita. These are the questions for further research as well as dependence of innovation and doing business environment on education expenditures.

## References

1. Alonso, J. D. and Sanchez, A. (eds.) (2011), *Reforming Education Finance in Transition Countries. Six Case Studies in Per Capita Financing Systems*, World Bank, Washington <https://openknowledge.worldbank.org/handle/10986/2332>
2. Barr, N. (1993). Alternative Funding Resources for Higher Education. *Economic Journal*, 103, (418), pp. 718-28.
3. Barr, N. (2003). Financing Higher Education: Lessons from the UK debate. *Political Quarterly*, 74 (3), 371-81. Reprinted in Barr, N. and Crawford, I. (2005). *Financing Higher Education. Answers from the UK*. London: Routledge, pp. 268-82.
4. Busemeyer, Marius R. Garritzmann, Julian L. Neimanns, Erik Nezi. Investing in education in Europe: Evidence from a new survey of public opinion. *Journal of European Social Policy*. Vol 28, Issue 1, 2018.



5. Chapman, B. (2005). 'Income Contingent Loans for Higher Education: International Reform'. Discussion Paper No. 491. Australian National University, Centre for Economic Policy Research. [Draft of Chapman 2006a, <http://econrsss.anu.edu.au/pdf/DP491.pdf>]
6. Dearden, L. and Fitzsimons, E. and Wyness, G. (2014), "Money for Nothing: Estimating the Impact of Student Aid on Participation in Higher Education", *Economics of Education Review*, 43, 66-78
7. Douglass, J. A. (2012, February). Money, Politics and the Rise of For-Profit Higher Education in the US: A Story of Supply, Demand and the Brazilian Effect | Center for Studies in Higher Education (CSHE). Retrieved January 6, 2017, from <http://www.cshe.berkeley.edu/publications/money-politics-and-rise-profit-higher-education-usa-story-supply-demand-and-brazilian>
8. Duflo, Esther, Rema Hanna, and Stephen P. Ryan. 2012. Incentives Work: Getting Teachers to Come to School: Dataset. *American Economic Review*. <http://dx.doi.org/10.1257/aer.102.4.1241>
9. European Commission/EACEA/Eurydice, 2014. Financing Schools in Europe: Mechanisms, Methods and Criteria in Public Funding. Eurydice Report. Luxembourg: Publications Office of the European Union.
10. Finnie, R. and Usher, A. (2006). The Canadian experiment in cost sharing and its effects on access to higher education, 1990-2002. In Teixeira, P. et al. (Eds.) *Cost-Sharing And Accessibility in Higher Education: A Fairer Deal?*. Dordrecht: Springer, 159-87.
11. Levačić, R. (2011). Per Capita Financing of General Education in Estonia, in J. D. Alonso and A. Sanchez (2011)
12. Lung Maria, Moldovan Ioan , Nistor Lung Alexandra. (2012) Financing Higher Education in Europe: Issues and Challenges. *Procedia - Social and Behavioral Sciences* № 51, p. 938 – 942.
13. Mărginean Ioan (2014) Public expenditure with education and healthcare in EU countries. *Procedia Economics and Finance* № 8, p. 429 – 435.
14. Mihály Fazekas (2014) School Funding Formulas - Review of Main Characteristics and Impacts OECD. Education Working Paper No. 74
15. Jencks, C. and Areen, J. *Educational Vouchers: A Proposal For Diversity And Choice. - Restructuring American Education*, 2017 - [taylorfrancis.com](http://taylorfrancis.com).
16. Nagy S.G., Kováts G., Németh A.O. (2014) Governance and Funding of Higher Education—International Trends and Best Practices. *Procedia—Social and Behavioral Sciences*, № 116, p. 180–184.
17. The role of the government in education from Milton Friedman (1962/1982), *Capitalism and Freedom* (Chicago, IL: University of Chicago Press).
18. Wilkinson, R. (2005). *Aiding Students, Buying Students: Financial Aid in America*. Nashville: Vanderbilt University Press.

# Simulation of the Crisis Contagion Process Between Countries with Different Levels of Socio-Economic Development

Andriy Matviychuk<sup>[0000-0002-8911-5677]</sup>, Inna Strelchenko<sup>[0000-0001-5179-4304]</sup>, Serhii Vashchaiev and Halyna Velykoivanenko<sup>[0000-0001-6326-3965]</sup>

Kyiv National Economic University named after Vadym Hetman,  
54/1 Peremogy Avenue, Kyiv, 03680, Ukraine

editor@nfmte.com, iistrelchenko@gmail.com,  
dean.fisit@kneu.edu.ua, ivanenko@kneu.edu.ua

**Abstract.** The paper contains a detailed analysis of the occurrence and contagion of crisis phenomena in countries with different levels of economic development. As part of the study, a correlation analysis of classification characteristics was carried out for the preliminary division of countries into classes. The usage of neural networks tools for the mathematical modelling of the processes of transboundary contagion of crisis is substantiated. A general scheme of the system of models of transboundary distribution of crisis phenomena between countries has been built. At the first level of the scheme for dividing countries into separate groups according to types of reaction to crisis phenomena, it was proposed to cluster them using self-organizing maps. At the second level of the scheme it was decided to use a perceptron-type neural network to predict the effects of crisis transfers.

**Keywords:** crisis contagion, financial market, macroeconomic indicators, classification, perceptron, self-organizing map

## 1 Introduction

Since the 90s of the twentieth century, the world economy has experienced several waves of economic crises, covered all countries of the world. Such universality and speed of crisis contagion is predetermined, first of all, from expansion of Internet network and accelerated rates of switch to electronic money.

Specific features of modern economic crises are: the existence of a source country, in the economy of which the systemic infringements in the functioning of one or several economy sectors (financial for the most part) are born and recorded; and the time-dispersed processes of transboundary contagion of negative trends between countries.

The experience of studying the consequences and coverage of the latest world economic crises suggests that reviews of economic systems with different levels of development and initial conditions differ significantly.

Given all this, there is an urgent problem of rethinking and supplementing the existing methodology for assessing the country's economic security. In particular it's

necessary to take into account and assess the consequences of the crisis transfer to the national economy.

## **2 Purpose and Objectives of the Study**

The purpose of this study is to build a generalized scheme of a system of models of transboundary contagion of crisis between countries with different levels of socio-economic development. The purpose of the study calls for the following tasks:

1. analysis of the subject area and definition of the object of study;
2. analysis of existing approaches to modelling the processes of crisis contagion;
3. identification of features that are important for the selection of modelling tools;
4. substantiation of the choice of mathematical tools for describing the transboundary contagion of crisis between countries with different levels of socio-economic development;
5. selection of a set of criterion for preliminary separation of domain objects into classes;
6. construction of a generalized scheme of the system of models of transboundary distribution of crisis phenomena between countries with different levels of socio-economic development based on the chosen mathematical tools;
7. implement the developed system of models in specialized software module in MATLAB.

## **3 Study Summary**

As the direction of the study, the contagion of crisis between the elements of a particular closed system is not new. The task of a formal description of the contagion processes of certain properties or regularities from one object to another has been sufficiently studied in the natural sciences: physics, biology, medicine. In particular, the mathematical models of the dynamics of epidemics, models of wave propagation in various environments, and equations of the reaction-diffusion type are justified and constructed.

In economic theory, the study of such phenomena is focused on identifying the hidden mechanisms for launching sharp negative changes in the financial markets and is aimed at predicting their subsequent appearance. To date, only a small number of studies focus on the study and formal description of the other side of the crisis: the transboundary contagion of a significant deterioration in the economy functioning of one country to other countries.

Among the fundamental studies in this trend, it is necessary to single out the works of S. Schmukler and J. Franklin [1], S. Calvo and C. Reinhart [2], J. Sachs, A. Tomell and A. Velasco [3]. V. Danich [4] is an important contributor to the study of avalanche processes in the economy.

To determine the boundaries of the object of study, let us consider the basic provisions of the main theoretical concepts of this trend.

Within the W. Kermack and A. McKendrick Susceptible-Infected-Removed model (SIR), the infection "spreads either directly or indirectly from an infected to a suscep-

tible individual through discrete time and is divided into periods of occurrence and contagion" [5]. According to the theory of wave propagation, the process of fluctuation transfer is accompanied by movement of matter in time through an oscillatory medium [6].

V. Danich defines the socio-economic avalanche process as "the spread of a certain property or state in the environment of subjects of socio-economic relations with the help of socio-psychological mechanisms of infection, imitation, suggestion, which leads to a change in the economic situation or environment (demand, supply, methods of management) in a certain market segment" [4].

Taking into account the common features inherent in the phenomena of the transfer of certain regularities and properties between the elements of one system in the space, in the future, according to the purpose and objectives, object of study shall be considered as "the processes of transboundary contagion of crisis between countries with different levels of economic development from the country-sources through accessible channels of infection, which lead to a significant deterioration of the economic situation in the country".

The process of crisis contagion between countries during time can be schematically represented as follows. Let's introduce the concept: period of occurrence ( $l$ ) is the time interval from the beginning of the crisis in the source country ( $t_0$ ) until the time when the crisis begins in the country under study ( $t_p$ ), and the response period ( $v$ ) is the time interval from the moment  $t_p$  to the moment of time when recorded a reduction in the rate of economic decline ( $t_k$ ).

To date, the most well-known theoretical and methodological approaches to analyzing and predicting crises in the economy (in particular, financial crises) are the following:

1. Classic Theory of Cyclical Fluctuations in economics: developed in the works of J. Sismondi (explaining the emergence of economic crises by the fact that too much of the income is saved and a very small part of it is spent on consumer goods, as a result of which the balance between the production and sale of the produced product is violated), J. Keynes [7] (considered the variable nature of investment as the main cause of economic fluctuations, among the root causes of distrust of the market and readiness for panic, he called "instability of the business psyche of a significant part of market participants"), J. Hicks [8] (according to whom, economic fluctuations are due to the impact of the investments on the change in output), N. Kondratiev [9] (considered long periods of disruption and recovery of economic equilibrium in close relationship with the processes of depreciation of fixed capital and cyclical nature of investment), J. Schumpeter, S. Kuznets and others.

2. Balance of Payment Deficit Theory. For the first time the model was formalized in the works of P. Krugman: [10] he described that under the conditions of a fixed exchange rate, the main cause of the crisis is the financing of the budget deficit by increasing public debt. Over time, this leads to a critical reduction in gold and foreign exchange reserves, and once their level reaches the limit, the Central Bank of the country is no longer able to maintain a fixed rate. Subsequently, the Krugman model was complicated, additional variables were introduced: mistrust of the existing currency regime, the level of price flexibility, the likelihood of speculative attacks, the change in public debt, the state policy, etc.; alternative regimes were considered after abandoning a fixed rate [11].

3. Monetary Model of Exchange Market Pressure. Used to analyze and isolate the moments or periods when a speculative attack on the national currency leads to a sharp depreciation and / or a significant reduction in gold and foreign exchange reserves. To determine similar periods, the index of exchange market pressure (IEMP) is calculated as a weighted average of the degree of change in the exchange rate of the currency and the volume of gold and foreign currency reserves [12].

4. Self-fulfilling Crises Theory. It is the newest concept in the list of assumptions regarding the causes of financial shocks. Proposed for the first time by M. Obstfeld [13] it considers the behaviorist approach in explaining the causal relationships of the "avalanche" growth of negative trends in the economy. The very term "self-fulfilling" is borrowed from sociology, where it has been used since 1948 to explain the mechanism of autosuggestion [14]. The Theory of Self-fulfilling Crises suggests that sharp negative trends in the economy are preceded by an unjustified growth of negative expectations among market participants. Thus, a biased information wave, spreading among investors, causes capital outflow and in leads to devastating consequences for the country's economy a short period of time, even in the absence of initial objective conditions for their occurrence.

According to the purpose and objectives of the study and taking into account the features of the object of the study, we formulate a list of requirements for mathematical tools:

1. To model the uneven consequences of cross-border contagion of economic shocks at the stage of introduction of explanatory variables it's necessary to consider the differentiation of the set of initial conditions that significantly affect the course of the crisis within the national economies.

2. It is necessary to take into account the nonlinear relationships inherent in the object of the study.

3. In order to classify the initial information within the same system of models and predict the consequences of the contagion of economic shocks, it is necessary to ensure parallel use of several types of computing subsystems for implementing advanced approaches to processing the input data.

4. For ease of operation, the model must have the ability to adapt in case of initial data change and dynamically adjust the parameters.

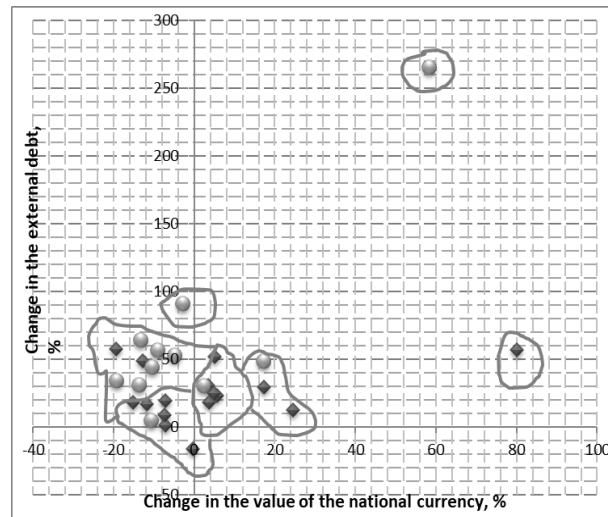
5. The practical significance of the constructed model directly depends on the possibility of an economic interpretation of the results obtained.

It is understandable that the consequences of the contagion of economic shocks, which result in the fall of the gross domestic product, the value of the national currency or the price of government bonds, are different for different countries. Therefore, the objective is to classify the countries under study in accordance with a certain set of criteria.

To simplify this stage, we can try to use the already developed system used by the IMF and the UN. It covers 181 member countries of the institution and divides countries according to the level of a market economy development to: developed market economies; emerging economies.

Let us estimate the possibility of using this classification system within this study. Based on statistical information on the course of the global crisis of 2007-2009, we construct a data field where the location of each point is determined by the coordi-

nates 'x' (percentage change in the value of the national currency) and 'y' (percentage change in the external debt). We denote seven conditional types of countries with different levels of response of economic on global crisis using markers of two types: a black rhombus – developed market economies and grey circle – emerging economies (Fig. 1).



**Fig. 1.** Point diagram of the 2007-2009 crisis impact on the economy of different countries

Interestingly, that the countries of each of the two groups on the IMF typology fell in the most zones. This makes it clear that this classification system is not convenient and universal for modeling the transboundary contagion of crisis between countries with different levels of economic development and does not correspond to the objectives of the study.

For the selection of classification criteria we use a statistical sample of economic indicators of 36 countries of the world. The sample included all two types of countries in the IMF classification:

1. Advanced economies (Austria, Italy, Netherlands, Belgium, Spain, France, Germany, United States, Japan, Greece);
2. Emerging economies (Ukraine, Hungary, Poland, Russian Federation, Kazakhstan, Bulgaria, Vietnam, Colombia, Malaysia, Philippines, Peru, South Africa, China, Argentina, Jamaica, Ghana, Sri Lanka, Indonesia, Pakistan, El Salvador, Brazil, Chile, Tunisia, Ecuador, Egypt, Turkey).

We calculate the correlation index between each classification criterion (the corruption perceptions index, the index of competitiveness, the globalization index, the economic freedom index, and the exchange rate flexibility index) and the level of GDP change, the national currency rate, the external debt. The results of the calculations are given in Table. 1.

**Table 1.** Values of the correlation indexes between the classification criterion of countries and the indicators of the crisis contagion consequences

Indicator of the crisis contagion consequences	Classification Criterion				
	Corruption Perceptions Index, points	Index of Competitiveness, points	Globalization Index, points	Index of Economic Freedom, points	Index of Exchange Rate Flexibility
GDP Growth Rate, %	-0.2436	-0.2378	-0.2764	-0.4253	-0.4522
National Currency Rate, %	0.3873	0.3875	0.1625	0.238	0.575
<b>External debt, %</b>	<b>-0.3613</b>	<b>-0.419</b>	<b>-0.2661</b>	<b>-0.1065</b>	<b>-0.3911</b>

Information for calculating the correlation indexes for the first four indexes can be found on available websites [15-18]. Index of Exchange Rate Flexibility (*ERF*) is calculated by the following formula [19]:

$$ERF_t = \frac{ME_t}{MR_t} = \frac{\sum_{k=0}^{11} |E_{t-k} - E_{t-k-1}| / E_{t-k-1}}{\sum_{k=0}^{11} |R_{t-k} - R_{t-k-1}| / H_{t-k-1}}, \quad (1)$$

where  $E_{t-k}$  – nominal exchange rate for  $k$  months till the current time  $t$ ,  $R_{t,k}$  – net foreign exchange reserves excluding gold reserves in  $t-k$  month,  $H_{t,k}$  – money supply in  $t-k$  month.

Based on the results of the correlation analysis, we assume that there is an interrelation between the selected classification criterion and indicators, reflecting the consequences of the crisis contagion between countries. We note that in this particular case the use of the Pearson correlation index is rather arbitrary and does not purport to directly estimate the coupling density between the variables.

However, the correlation indexes obtained low values. It can be explained by the nonlinearity of the relationships between the indices. This once again testifies to the futility of constructing linear models and makes it expedient to use mathematical tools that can effectively detect nonlinear regularities, in particular, neural networks.

The neural network is a mathematical tool that realizes the idea of processing information on the principle of the nervous system. The optimized network is able to build approximations for a wide class of dependencies between input parameters and the result. One of their advantages is no need for a strict mathematical specification of the model (this property is especially valuable for an adequate description of the object of study that belongs to the class of weakly formalized processes). Also, neural networks are robust, that is, they are resistant to changes in external conditions and can work with a large volume of inconsistent and incomplete information.

Among the variety of types of neural networks, the architecture known as the Kohonen Self-Organizing Map (SOM) [20] is better suited for the classification task, which is a single layer of neurons organized in the form of a two-dimensional matrix. This arrangement of neurons makes it possible to obtain a visual display of multidimensional input data. This allows to cluster the objects of study on the neurons of the

map, to carry out further analysis of the weights of the neurons and the results of the distribution of examples across clusters.

When you configure the map, its examples are provided with case studies. At each step, a neuron that has a minimal scalar product of the weights of the bonds and the input vector is defined. Such a neuron is designated as the winner in the competition of map neurons and becomes the center when adjusting the weights of both its and neuron neighbors connections.

To carry out the procedure of countries preliminary classification on the basis of the Kohonen map, we will use all five characteristics: the corruption perception index, the index of competitiveness, the globalization index, the economic freedom index, and the index of exchange rate flexibility. Taking them into account when dividing countries into classes allows us to describe the characteristics and initial conditions with which each country enters to latent period of occurrence of the crisis.

The next stage in modeling the process of transboundary crisis contagion is the construction of a neural network to predict the depth of the economic downturn in the country. The analysis of macroeconomic indicators and their testing made it possible to formulate a list of indicators of crisis processes contagion between financial sectors of different countries by the one of type of contagion channel – financial or trading (see Table 2).

**Table 2.** Indicators of transboundary contagion of crisis processes between the financial sectors of different countries

Group and Name of the Indicator	Calculation Methodology
<b>Macroeconomic indicators for assessing economic security</b>	
Ratio of the official international reserves volume to the gross external debt, %	In accordance with the methodological recommendations of relevant international financial organizations and funds
Ratio of M2 money supply to gold and foreign exchange reserves, %	
Spread of the real interest rate in the country to the same indicator abroad, % of points	
M2 money supply, %	
Deposits of commercial banks, adjusted for the consumer price index, % to the previous period	
Index of exchange market pressure (IEMP)	Weighted average of three components: changes in the exchange rate, changes in the nominal interest rate and the volume of reserves
<b>Indicators assessing the level of liberalization and integration of the stock market</b>	
Index of stock market liberalization	global index (IFCG) / investment index (IFCI)
Index of international financial integration (IFI), %	(foreign assets + financial liabilities of a country) / GDP
Net foreign assets (NFA)	By the International Monetary Fund
Corruption perception index (CPI)	By Transparency International
<b>Indicators assessing the relationship between the real and financial sectors of the economy</b>	
Tobin's index (elite enterprises shares of which are included in the stock indexes), %	market value of the company's assets / balance sheet capital
Monetization factor, %	M2 money supply (cash, cash on the accounts of enterprises and household deposits in banks) / GDP



Export of goods and services, % compared to the previous period	In accordance with the methodological recommendations for assessing the level of economic security of Ukraine
Terms of trade index (price), %	
Import of goods and services, % compared to the previous period	
Share of exports in total GDP, % compared to the previous period	[export income / GDP (previous period)] / [export income / GDP (previous period)]
Share of raw materials export income, %	raw materials export income / GDP

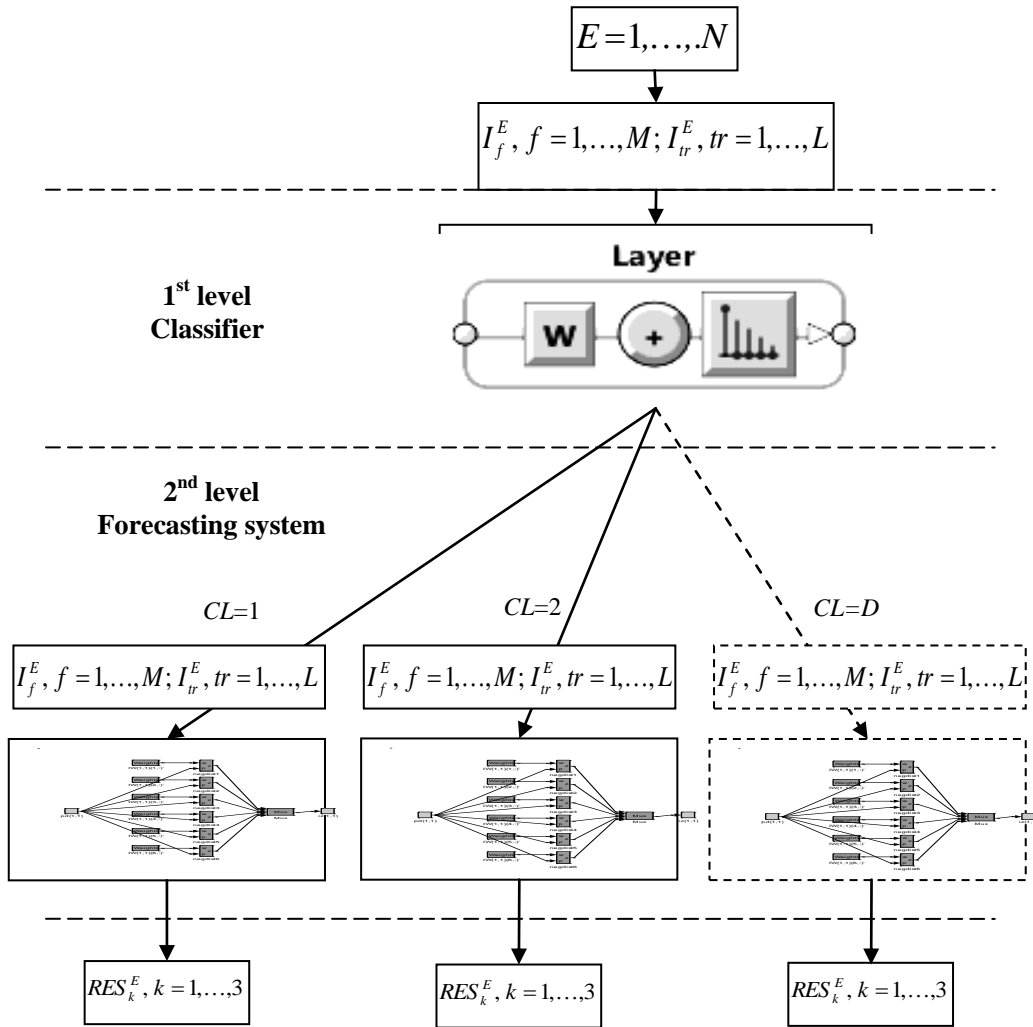
Let us consider a system consisting of economies of  $N$  countries ( $E=1, \dots, N$ ). Each economy is characterized by a set of macroeconomic indicators that record the spread of economic crises through financial ( $f$ ) or trade ( $tr$ ) channel ( $I_f^E, f=1, \dots, M; I_{tr}^E, tr=1, \dots, L$ ). According to the conditions inherent in each particular economy at time  $t$ , it can be assigned to a certain class ( $CL=1, \dots, D$ ). The consequences of the crisis for the economy of an arbitrary country can be estimated on the basis of a set of three indicators: changes in GDP, the rate of the national currency, the value of external debt ( $RES_k^E, k=1, \dots, 3$ ). Then the processes of transboundary contagion of crisis can be described by a scheme of system of models based on neural networks, as shown in Fig. 2.

As can you see from Fig. 2, the scheme of calculations consists of two levels. Each level implements one of the modeling tasks – classification or forecasting. At the first level, countries are divided into clusters according to the system of classification criterion (corruption perceptions index, exchange rate flexibility index, competitiveness index, etc.). At the second level, the task of forecasting the main macroeconomic indicators of the economy shrinks due to the crisis contagion is being solved.

The system of models presented in Fig. 2 is implemented as a separate software module in the MATLAB system and consists of two subsystems. The calculation was made based on statistical information on the course of the global crisis of 2007-2009.

The first model, based on the Kohonen map, implements the classification of researched countries by the type of reaction to the processes of cross-border transfer of crisis phenomena in financial markets. As a result of the algorithm it's obtained the Kohonen map, consisting of six clusters. Each of them is associated with a particular scenario of economic behavior of countries belonging to it:

1. Euro Area, Estonia, Lithuania, Czech Republic, Denmark, Israel, Singapore, Switzerland, United States, Brunei Darussalam, Malaysia, Myanmar, Philippines, Thailand, Albania, Bosnia and Herzegovina, Bulgaria, Croatia, Latvia, Macedonia, Montenegro.
2. Australia, Canada, New Zealand, Norway, Sweden, Indonesia, Kiribati, Samoa, Tonga, Vanuatu, Hungary, Poland, Serbia Republic.
3. Bangladesh, Armenia, Georgia, Moldova.
4. Iceland, South Korea, United Kingdom, Bhutan, India, Nepal, Solomon Islands, Romania, Turkey.
5. Special administrative region of China Hong Kong, China, P.R.: Macao, Japan, China P.R.: Mainland, Lao People's Democratic Republic, Papua New Guinea, Azerbaijan.
6. Cambodia, Fiji, Mongolia, Sri Lanka, Vietnam, Kazakhstan, Belarus, Kyrgyz Republic, Russian Federation, Tajikistan, Ukraine.

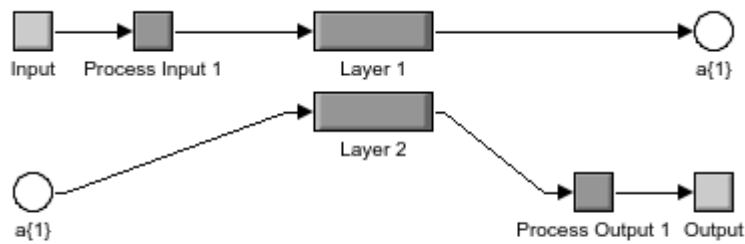


**Fig. 2.** Generalized scheme of the system of models of transboundary contagion of crisis between countries with different levels of socio-economic development

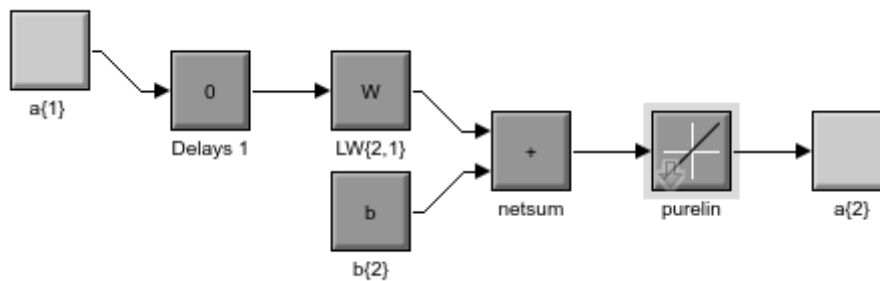
Clusters #1 and #2 combine countries characterized by a short economic recovery period and a fairly rapid return of key macroeconomic indicators to pre-crisis levels. The longer period of recovery and the higher volatility of exchange rates, gross domestic product and the reduction of export-import operations are characterized the third and fourth cluster of the Kohonen map. As for the countries from the last two clusters (including Ukraine), as a result of the crisis the average estimate of macroeconomic indicators dropped is more than 15% for the sixth cluster and by 9% for cluster #5. It is also important to note that the SOM has included in one group the countries, which are geographically neighbors with historically established close economic ties.

The second subsystem that implements the forecasting process was built on the basis of the neuron network of the perceptron type. The trained neural network performs the forecasting of the scenario of the studied country economic development under the impact of transboundary transfer processes of crisis phenomena in financial markets by establishing a correspondence between the pre-crisis level of macroeconomic indicators characterizing financial and trading channels of crisis contagion (see Table 2) and one of the six clusters obtained on the previous stage.

A detailed structure of the neural network for predicting the scenarios of response of studied economics in terms of basic macroeconomic indicators fall shown in Figures 3-4.



**Fig. 3.** A detailed structure of a two-layer neural network of perceptron type. Source: built by authors in SIMULINK



**Fig. 4.** A detailed structure of second layer of neural network of perceptron type. Source: built by authors in SIMULINK

The obtained results of carried out experiments indicate the high level of reliability of the obtained model. Constructed perceptron-predictor with a probability of 77% determines the scenario of the behavior of the studied economy in the processes of cross-border transfer of crisis phenomena in financial markets through available distribution channels.

## 4 Conclusions and Outlook

As a result of the research, weaknesses in the study of crises were identified and the need for analysis and modeling of the processes of crisis transboundary contagion in countries with different levels of economic development is emphasized. The essence of the object of study is revealed and its definition is formulated. According to the purpose, objectives and the object of study, a theoretical substantiation of the usage of neural networks as a mathematical tool is given.

Note that a separate transfer scenarios not addressed the crisis between the two countries, such as between developed and developing countries or between developing countries, etc. The problem of this type does not seem expedient to the authors, because isolate pairwise relations between countries in terms of transnational corporations and the electronic money is not possible. In this study, the transfer of the crisis is considered by analogy with the contagion of epidemics in natural sciences [5].

For the purpose of the primary division of the totality of countries into classes, a correlation analysis of the classification characteristics is carried out. Conclusions on the inadequacy of common approaches to the goals of modeling are made.

A generalized scheme of a system of models of crisis transboundary contagion between countries with different levels of socio-economic development based on neural networks is constructed. At the first level of the scheme, it is suggested to use Kohonen self-organizing maps to divide countries into separate groups according to the types of reaction to crises. To predict the consequences of crisis contagion at the second level of the scheme it was decided to use a perceptron type neural network.

An important advantage of the built system of models based on neural networks, besides the ability to forecast the scenarios of behavior of the national economy during the crisis on world capital markets, is the possibility of determining the elasticity of each of the indicators of the transmission channels to form an adequate situational policy of adaptation to imbalances in the source country's economy and mitigate its effects.

## References

1. Schmukler, S., Frankel, J.: Country Fund Discounts and the Mexican crisis December 1994: Did Local Residents Turn Pessimistic Before International Investors? *Open Economies Review* 5, 511-534 (1996)
2. Calvo, G., Reinhart, C.: Capital Inflows and Real Exchange Rate Appreciation in Latin America. *International Monetary Fund* 40, 108-151 (1995)
3. Sachs, J., Tornell, A., Velasco, A.: Financial Crises in Emerging Markets: The Lessons from 1995. *Brookings Papers on Economic Activity* 27(1), 147-216 (1996)
4. Danich, V. N.: Identifikacia bystrykh processov. *Metody i modeli*. Art-Biznes-Centr, Moscow [in Russian] (1999)
5. Kermack, W. O., McKendrick, A. G.: Contribution to the mathematical theory of epidemics. *Proc. Roy. Soc. Ser. 115*, 700-721 (1927)
6. Gorelik, G. S.: *Kolebaniya I volny. Vvedenie v akustiku, radiofiziku i optiku*. Fizmatlit, Moscow [in Russian] (2007)
7. Keynes, J. M.: The General Theory of Employment. *The Quarterly Journal of Economics* 2., 209-223 (1937)

8. Hicks, J. R.: Value and Capital: Growth Model. Oxford University Press 26(3), 159-173 (1959)
9. Kondrat'ev, N. D.: Problemy ekonomicheskoi dinamiki. Ekonomika, Moscow [in Russian] (1989)
10. Krugman, P.: A Model of Balance-of-Payments Crises. Journal of Money, Credit and Banking 1(3), 311-325 (1979)
11. Garber, M., Svensson, E.O.: The Operation and Collapse of Fixed Exchange Rate Regimes. Handbook of International Economics 3, 1865-1911 (1995)
12. Girton, L., Roper, D. A.: Monetary Model of Exchange Market Pressure Applied to Post-war Canadian Experience. American Economic Review 67, 537-548 (1977)
13. Obstfeld, M.: Rational and Self-Fulfilling Balance-of-Payments Crises. American Economic Review 76, 72-81 (1986)
14. Merton, R.: The Self-Fulfilling Prophecy. Antioch Review 8, 193-210 (1948)
15. Transparency International: Table of Results: Corruption Perceptions Index. <http://www.transparency.org/>
16. KOF Swiss Economic Institute: KOF Globalization Index. <http://www.globalization.kof.ethz.ch>
17. The Heritage Foundation. <http://www.heritage.org>
18. World Economic Forum: Reports. <https://www.weforum.org/reports/>
19. Poirson, H.: How Do Countries Choose Their Exchange Rate Regime? IMF Working Paper WP/01/46, 1-33 (2001)
20. Kohonen, T.: Self-organizing maps, 3rd ed, Springer, New-York (2001)

# Computations in Extensions of Multisorted Algebras

Michael Lvov <sup>[0000-0002-0876-9928]</sup>

Kherson State University, 27, Universytets'ka St., 73000 Kherson, Ukraine

Lvov@ksu.ksu.ua

**Abstract.** Development of algorithms of algebraic computations is one of the main problems, which arises with realization of mathematical software based on symbolic transformations. Multi-sorted algebraic systems (MAS) are mathematical model for this problem.

Present paper deals with the solution of this problem. We propose the approach to realization of interpreters of multi-sorted algebraic operations by its specifications, based on constructive improvement of notion of extension of multi-sorted algebraic system. This approach is illustrated by examples of realization of interpreters of operations in the field of rational numbers, ringing of one variable polynomial over the field, algebra of Boolean functions. Practice of this approach using for development of mathematical educational software shows its effectiveness and even universality.

**Keywords.** systems of computer mathematics, symbolic computations, multi-sorted algebras, extensions of algebras, interpreters of algebraic operations.

## Introduction

Development of algorithms that perform algebraic computations is one of the main problems that arise when one implements mathematical systems based on symbolic transformations. A mathematical model of this problem is the notion of a multi-sorted algebraic system (MAS). The practice of development of simple educational mathematical systems [1, 2, 3] showed that implementation of algebraic computations requires careful preliminary design of MAS via development of MAS sort hierarchies and specifications of interpreters of multi-sorted algebraic operations [8]. Due to a number of reasons [9], for implementing calculations based on symbolic transformations we use the system of algebraic programming APS [4, 5, 6] which was adapted for our purposes by V. Peschanenko [10].

APS uses an algebraic programming technology based on rewriting systems and rewriting strategies. Thus, an interpreter of an algebraic operation is defined by a system of rewriting rules.

## 1 Problem formulation

In the paper we propose an approach to implementing interpreters of multi-sorted algebraic operations in accordance with their specifications which is based on the constructive refinement of the concept of an extension of a multi-sorted algebraic system. The definitions of a MAS and its (constructive) extension are given in paragraph 1. A typical example of a constructive extension is the example of the field of rational numbers as an extension of the ring of integers (example 2).

Constructive MAS extensions are classified as static, linear or binary dynamic extensions (definition 1.3.1, 2.1.).

We show that an interpreter of an algebraic operation in a constructive extension can be synthesized automatically in accordance with its specification which defines the rules of interpretation of the operation in extension, and the conditions of embedding of the base algebra in its extension.

The algorithm of synthesis of an interpreter of an operation is determined by the type of an extension. Therefore, in paragraph 2.2 we give examples of implementation of interpreters of operations of the field of rational numbers (static extensions), quadratic radicals field (binary dynamic extensions), univariate polynomial rings (linear dynamic extensions) and the algebra of propositions (binary dynamic extensions).

### 1.1 Multi-sorted algebras as mathematical model of algebraic computations

**Definition 1.1.** Let  $U = \{u_1, \dots, u_k\}$  be a finite set of symbols which is called the sorts signature. The symbols  $u_l$ ,  $l \in \{1, \dots, k\}$  are called the names of sorts, or simply the sorts.

In particular, we will use the following sort names: *Variable*, *Bool*, *Nat*, *Int*, *Real*.

We will introduce other sort names within the definitions of the appropriate algebraic notions.

**Definition 1.2.** Let  $\bar{S} = \{S_{u_1}, \dots, S_{u_k}\}$  be a finite family of sets indexed by sort names, the elements of which are called the value ranges of the corresponding sorts:

- $S_{Variable}$  is the set of variables,
- $S_{Bool}$  is the set  $\{\text{False}, \text{True}\}$ ,
- $S_{Nat}$  is the set of natural numbers,
- $S_{Int}$  is the set of integers,
- $S_{Real}$  is the set of real numbers.

**Definition 1.3.** A multi-sorted operation  $f$  on a family  $\mathbf{S}$  is a map  $f : S_{u_1} \times S_{u_2} \times \dots \times S_{u_m} \rightarrow S_v$ , where  $u_1, \dots, u_m, v \in \mathbf{U}$  are sorts of arguments and values of the operation  $f$ , respectively, and  $m$  is the arity of  $f$ .

The type of an operation is determined by the list of names of sorts of its arguments and the name of the sort of its range of values. The type of an operation  $f$  will be denoted as  $(u_1, \dots, u_m) \rightarrow v$ . A signature  $\Sigma$  of operations is a finite set of symbols of operations together with a map that associates with each symbol  $\varphi \in \Sigma$  a multi-

sorted operation  $f_\varphi$  together with its type (if  $\varphi$  is a symbol of an operation, then the expression  $\varphi:(u_1, \dots, u_m) \rightarrow v$  that this symbol is associated with an operation of the type  $(u_1, \dots, u_m) \rightarrow v$ ).

An example of a multi-sorted operation is scalar multiplication in a vector space. If *VectorSpace* is the sort name of a set of vectors over the field *Real* of real numbers, then the multiplication operation *Mult* “\*” defines the map

$$\text{Mult} : \text{Real} \times \text{VectorSpace} \rightarrow \text{VectorSpace}$$

Below we will use more common, traditional mathematical notations for operations. Since the infix notation is usually used for scalar multiplication, we have:

$$\text{Real} * \text{VectorSpace} \rightarrow \text{VectorSpace}$$

**Definition 1.4.** Let *Bool* be a sort with the value range  $S_{Bool} = \{True, False\}$ . A multi-sorted predicate  $P$  is a mapping  $P: S_{u_1} \times \dots \times S_{u_m} \rightarrow S_{Bool}$ , where  $u_1, \dots, u_m \in \mathbf{U}$ , the sequence  $u_1, \dots, u_m$  determines the type of the predicate, and the number  $m$  is its arity. A signature  $\Pi$  of multi-sorted predicates is defined analogously to the signature of operations as a set of operations of predicate symbols, associated with multi-sorted predicates together with their types.

**Definition 1.5.** A multi-sorted algebraic system  $\mathbf{A}$  is a tuple  $\mathbf{A} = \langle \mathbf{S}, \mathbf{U}, \Sigma, \Pi \rangle$ , where  $\mathbf{S}$  is a set of sorts indexed by the symbols of the set  $\mathbf{U}$ ,  $\Sigma = \{\varphi_1, \dots, \varphi_l\}$  is a signature of multi-sorted operations,  $\Pi = \{\pi_1, \dots, \pi_p\}$  is a signature of multi-sorted predicates.

**Remark.** Since the sort *Bool* can be added to the set of sorts, predicates can be considered as multi-sorted operations. Therefore, instead of considering multi-sorted algebraic systems, we will combine the signatures of operations and predicates and consider multi-sorted algebras.

**Definition 1.6.** Let  $\mathbf{A} = \langle \mathbf{S}, \mathbf{U}, \Sigma \rangle$  be a multi-sorted algebra and  $u, v \in \mathbf{U}$  be sort symbols. We will say that the sort  $v$  depends on the sort  $u$ , if one of the operations of the signature  $\Sigma$  has the type of the form  $u_1 \times \dots \times u \times \dots \times u_m \rightarrow v$ . As  $\mathbf{U}_v$  denote a subset of sorts which depend on the sort  $v$ . Denote the subset of elements of  $\Sigma$  of type  $u_1 \times \dots \times u \times \dots \times u_m \rightarrow v$  as  $\Sigma_v$ , and the family of ranges of values of sorts  $\mathbf{U}_v$  as  $\mathbf{S}_v$ . A restriction  $\mathbf{A}_v$  of a multi-sorted algebra  $\mathbf{A}$  to a sort  $v$  is the multi-sorted algebra  $\mathbf{A}_v = \langle \mathbf{S}_v, \mathbf{U}_v, \Sigma_v \rangle$ .

Thus, a multi-sorted algebra  $\mathbf{A}$  can be represented by a set of restrictions (algebras)  $\mathbf{A}_v, v \in \mathbf{U}$ , that  $\mathbf{A} = \langle A_{u_1}, \dots, A_{u_k} \rangle$ .

### Example 1

Consider a software system that implements simplification of algebraic and trigonometric expressions. The core of the system must implement the computations in the ring of polynomials and the ring of multivariate trigonometric polynomials over the field of rational numbers. Specifications shall be given for the following algebras – restrictions to the mentioned sorts:



**MultiPolynom** – the ring of multivariate polynomials.

$MultiPolynom + MultiPolynom \rightarrow MultiPolynom$

$MultiPolynom * MultiPolynom \rightarrow MultiPolynom$

...

**MultiTrig** – the ring of multivariate trigonometric polynomials.

$Sin(LinComb) \rightarrow MultiTrig$

$Cos(LinComb) \rightarrow MultiTrig$

$MultiTrig + MultiTrig \rightarrow MultiTrig$

...

**LinComb** – the vector space of linear combinations of several variables (arguments of trigonometric polynomials).

$Pi$

$LinComb + LinComb \rightarrow LinComb$

$Rat * LinComb \rightarrow LinComb$

...

**Rat** – the field of rational numbers (coefficients of polynomials and trigonometric polynomials).

$Rat + Rat \rightarrow Rat$

$Rat - Rat \rightarrow Rat$

$Rat = Rat \rightarrow Bool$

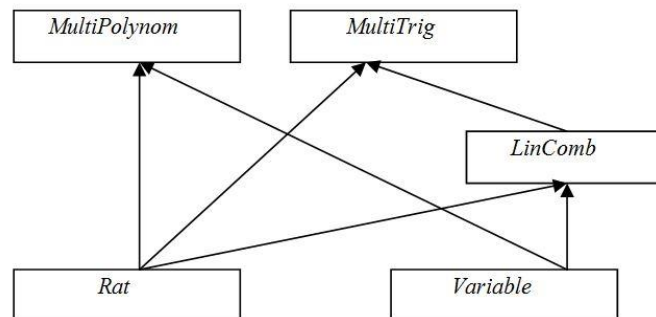
$Rat < Rat \rightarrow Bool$

...

The relation of dependence between sorts generates a structure of dependence on the set of algebras  $\mathbf{A}_u$ ,  $u \in \mathbf{U}$ : an algebra  $\mathbf{A}_v$  depends on the algebra  $\mathbf{A}_u$  if the sort  $v$  depends on the sort  $u$ . If the relation of dependence has no cycles, then a multi-sorted algebra can be constructed step by step (incrementally) by constructing an algebra  $\mathbf{A}_v$ , if algebras  $\mathbf{A}_u$  on which it depends are already constructed.

## 1.2 Axioms and constructs of multi-sorted algebra

For constructing algebras  $\mathbf{A}_u$  we use their axiomatic and constructive descriptions (definitions).



**Fig. 1.** Diagram of dependency of algebras of Example 1.

**Definition 1.7.** An axiom of an algebra  $\mathbf{A}_u$  is an identity or a conditional identity in a signature  $\Sigma_u$ . An axiomatic description in an algebra  $\mathbf{A}_u$  is a finite set of axioms (axiom system) of the algebra  $\mathbf{A}_u$ .

We will use algebraic terminology and the relevant systems of axioms from the book [11]. A constructive description of an algebra  $\mathbf{A}_u$  is a definition of a constructor of the sort  $\mathbf{S}_u$  (i.e. a definition of terms of sort  $\mathbf{S}_u$ ) and a set of interpreters of operations of  $\Sigma_u$ .

**Definition 1.8.** A signature of constructors  $T_u$  is a finite set of symbols of operations together with a map that with each symbol  $\tau \in T_u$  associates a symbols of the sort  $u$  together with a list of symbols of sorts of its arguments (if  $\tau$  an operation symbol, the expression  $u = \tau(u_1, \dots, u_m)$  means that this symbol is associated with the symbol of the sort  $u$  and the symbols of the sorts of its arguments  $u_1, \dots, u_m$ .)

A constructor of sort  $\mathbf{S}_u$  of an algebra  $\mathbf{A}_u$  is a system of equations which defines syntactically the elements of sort  $\mathbf{S}_u$  as terms in  $T_u$  signature. So, the sort  $\mathbf{S}_u$  is the set of terms in (its own) signature  $T_u$  of constructors of  $\mathbf{S}_u$  sort.

Definition 1.8 is the key one in our approach to specification of algebraic computations. Let us present the relevant examples and explanations.

**Example 2.** The field *Rat* of rational numbers.

Rational numbers are represented in the form of simple fractions. The constructor of a sort defines the standard representation of elements of this sort. The most common is the *canonical form*. That is why,

$$S_{Rat} = \left\{ \frac{p}{q} : p \in S_{Int}, q \in S_{Nat}, GCD(p, q) = 1 \right\} \quad (1)$$

Horizontal line is a symbol of the sort constructor. The same mathematical symbol is used to denote the operation of division, in particular in *Rat*. This is not convenient for the tasks of specification of algebraic computations. Therefore, we introduce the concept of a signature of operations  $\Sigma$  and a signature of constructors  $T$ . In particular, for denoting the constructor of the sort *Rat* we will use *double forward slash*:

$$S_{Rat} = \{ p // q : p \in S_{Int}, q \in S_{Nat}, GCD(p, q) = 1 \} \quad (2)$$

An important factor is that in the standard forms of presentation of elements of sorts the syntactic aspects of the definition are always combined with semantic aspects defined as contextual conditions i.e. predicates. In our case such a predicate is the equality  $GCD(p, q) = 1$ .

**Example 3.** The ring *Polynom* univariate polynomials over the field *Rat*.

Elements of this field are polynomials represented as sums of monomials, written in descending order of degrees. This definition should be recursive, and the concept of degree has to be defined separately.

$$S_{Polynom} = \{ Q : Q = M ++ P, M \in S_{Monom}, P \in S_{Polynom}, \deg Q = \deg M; \deg(M) > \deg(P) \} \cup S_{Monom} \quad (3)$$

To define the carriers of sorts we will use a special specification language, which allows non-recursive and recursive syntactic definitions of sorts' elements, definitions of the access functions and contextual conditions. For example:

```

Rat r = { (Int a) // (Nat b);    // Constructor of sort
  Num(r) = a, Den(r) = b;    // Access functions
  GCD(a, b) = 1              // Contextual condition
};
Monom M = { (Rat c)$(Const Variable x)^(Nat n);
  Coef(M) = c, Var(M) = x, Deg(M) = n // Access functions
};
Polynom P = { (Monom M)++(Polynom Q); // Constructor
  LeadMon(P) = M,           // Access functions
  LeadCoef(P) = Coef(M), Deg(P) = Deg(M);
  Deg(P) > Deg(Q)          // Contextual condition
};

```

In order to implement computations in an algebra  $\mathbf{A}_v$ ,  $v$  in  $\mathbf{U}$ , it is necessary to implement algorithms for performing each of its operations in such a way that the axioms of the algebra are satisfied.

**Definition 1.9.** An interpreter of an operation of a signature  $\Sigma_u$  is a function which is implemented by an algorithm which performs the corresponding operation.

Interpreters of operations are defined using a programming language. For our purposes we use *APLAN* language. So we include this language in the specification language.

Thus, for axiomatic and constructive description of an algebra  $\mathbf{A}_v$  to its definition we add a finite set of axioms  $Ax_v$  and finite set of interpreters  $I_v$ . Then a multi-sorted algebra  $\mathbf{A}_v$  is defined as follows:  $\mathbf{A}_v = \langle \mathbf{S}_v, \mathbf{U}_v, T_v, \Sigma_v, Ax_v, I_v \rangle$ .

### 1.3 The methods of construction of multi-sorted algebras

Construction of the structure of multi-sorted algebras means specification, prototyping and implementation of algebraic computations. Specification of the structure of multi-sorted algebra is done in terms of extensions, homomorphisms, isomorphism and inheritance of multi-sorted algebras. Thus, together with the diagrams of dependence, which are graphical models of specifications of signatures of operations and constructors, the diagrams of extensions, diagrams of morphisms (isomorphism and homomorphism) and diagrams of inheritance are designed. We consider the method of extension. The methods of morphisms and inheritance are beyond the scope of this work.

#### 1.3.1 The method of algebra extension

**Definition 1.10.** Let  $\mathbf{A}_u$  and  $\mathbf{A}_v$  be multi-sorted algebras. A multi-sorted algebra  $\mathbf{A}_v$  is called an extension of  $\mathbf{A}_u$ , if  $S_u \subseteq S_v$  and for any pair of operations  $f_1, f_2$  of types

$f_1 : (u_1, \dots, u_m) \rightarrow u$  and  $f_2 : (v_1, \dots, v_m) \rightarrow v$  respectively, if  $S_{u_1} \subseteq S_{v_1}, \dots, S_{u_m} \subseteq S_{v_m}$ , then  $\forall (a_1, \dots, a_m) \in S_{u_1} \times \dots \times S_{u_m}$  the equality  $f_1(a_1, \dots, a_m) = f_2(a_1, \dots, a_m)$  holds.

An embedding is an isomorphic map  $Red : \mathbf{S}_u \rightarrow \mathbf{S}'_v$ , which maps  $\mathbf{S}_u$  onto a subset  $\mathbf{S}'_v \subset \mathbf{S}_v$ . A restriction of an algebra  $A_v$  to a subset isomorphic to  $A_u$ , is determined by a system of conditional identities  $E_1(x), \dots, E_k(x) : \mathbf{S}_v = \{a \in \mathbf{S}_v \mid E_1(a), \dots, E_k(a)\}$ . The use of the system  $E_1(x), \dots, E_k(x)$  as a rewriting system «simplifies» the term  $a \in \mathbf{S}'_v$  to a term  $a' \in \mathbf{S}_u : Red^{-1}(a) = a'$ .

A constructive description of an extension  $\mathbf{A}_v$  means a description of a constructor of  $\mathbf{A}_v$  and an embedding of  $\mathbf{A}_u$  into an algebra  $\mathbf{A}_v$ . In Figure 2 the double arrow indicates that  $\mathbf{A}_v$  is an extension of the algebra  $\mathbf{A}_u$ , in  $\mathbf{A}_v$  the construct  $v = \tau(u_1, \dots, u_m, \dots, u_m)$  and embedding  $Red_{u,v}$  are defined.

**Note.** The relation of MAS extension (the relation “sort-subsort”) is basic in this work. Multi-sorted algebras, partially ordered by this relation, are called sorted-ordered. The fundamentals of the theory of sorted-ordered algebra in the applications to the theory of programming are presented in [12]. In Russian they are stated in [13].

**Example 4.** Consider the constructor of the field *Rat* (Example 2). According to the definition it defines a construct *Rat*, the arguments of which are sorts *Int* and *Nat*. Let us complement the specification of *Rat* sort by the embedding  $Red : Rat \rightarrow Int$ , defined by the equality  $Red(a//1) = a$ . Thus the sort *Rat* is defined constructively as an extension of sort *Int*.

Now consider the constructor of the *Polynom* ring (Example 3). It defines a recursive construct *Polynom*, the arguments of which is the sort *Monom*. Let us complement the specification of the sort *Polynom* with an embedding  $Red : Polynom \rightarrow Monom$ , defined by the equality  $Red(M++0) = M$ . So the sort *Polynom* is defined as an extension of the sort *Monom*.

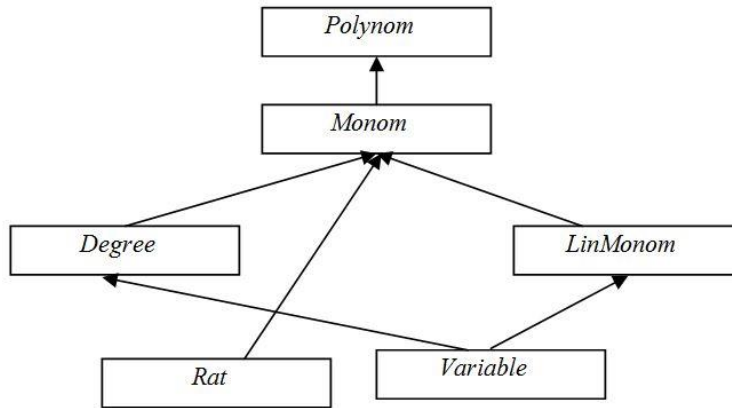


Fig. 2. Diagram of extensions in example 4.

In turn, the sort *Monom* is an extension of the sort *Degree* with a function *Red* defined by the equality  $1\$x^{k} = x^{k}$ , extension of the sort *LinMonom* with a function *Red* defined by the equality  $a\$x^{1} = a\$x$  and extension of *Rat* with a function *Red* defined by the equality  $a\$x^{0} = a$ . The Sorts *Degree* and *LinMonom* are extensions of the sort *Variable* with the functions of reduction, specified in accordance with the following equalities  $x^{1} = x$  and  $1\$x = x$ . Thus, the extensions diagram has the following form

The extension mechanism is one of the main methods of specification of multisort-algebras. In particular, it allows defining the overloaded algebraic operations and algebraic type casting functions.

## 2 Methods of synthesis of algebraic programs

### 2.1 Static and dynamic extensions

**Definition 2.1.** An extension  $B$  of an algebra  $A$  is called static (non-recursive), if in its constructor  $B = \varphi(A_1, \dots, A, \dots, A_n)$  none of the arguments coincides with  $B$ .

**Examples of static extensions:**

The field *Rat* is a static extension of the ring *Int*. Actually,  $RatR = (IntA)/(NatB)$

The semigroup of monomials *Monom* with one generator is a static extension of the coefficients *Coef* field, because  $MonomM = (Coef a)(Var.x)^{(NatN)}$ .

**Definition 2.2.** An extension  $B$  of an algebra  $A$  is called dynamic (recursive), if in its constructor  $B = \varphi(A_1, \dots, A, \dots, A_n)$  at least one of the arguments coincides with  $B$ .

A constructor of a dynamic extensions is a recursive definition, and therefore, contains both the base and recurrent part.

**Examples of dynamic extensions:**

A vector space *LinComb* of linear combinations of several variables over a field *Coef* is a linear dynamic extension of *LinMonom*, an element of which has the form  $a\$x$ . An element  $w \in LinComb$  has a form  $w = a_1\$x_1 + a_2\$x_2 + \dots + a_m\$x_m$ .

$LinComb w = (LinMonomu) ++ (LinComb w)$

An univariate polynomial ring *Polynom* over the field *Coef*. This ring is traditionally denoted as  $F[x]$ .

$Polynom w = (Monom M) ++ (Polynom w)$

**Definition 2.3.** A dynamic extension  $B$  of an algebra  $A$  is called linear, if in its constructor  $B = \varphi(A_1, \dots, A, \dots, A_n)$  exactly one of the arguments coincides with  $B$ .

A dynamic extension  $B$  of an algebra  $A$  is called binary, if in its constructor  $B = \varphi(A_1, \dots, A, \dots, A_n)$  exactly two of the arguments coincide with  $B$ .

**Example 5.** The field of square radicals

Examples 3 and 4 are examples of linear dynamic extensions. Consider an example of a dynamic binary extension:

The field *Rad*, the elements of which are linear combinations of square roots of square-free positive integers with rational coefficients, can be represented as a binary

extension of  $Rad$  using the following construction. Let  $p_1, p_2, \dots, p_n, \dots$  is a sequence of all prime numbers arranged in ascending order. Denote as  $Q$  the field of rational numbers. We introduce the following notations:

$$Rad_0 = Q, Rad_n = \{r : r = a + b * \sqrt{p_n}, a, b \in Rad_{n-1}, n=1, 2, \dots\}.$$

The field  $Rad$  is the union of the increasing sequence  $Rad_n$  of fields.

$$Rad = \bigcup_{n=0}^{\infty} Rad_n, Rad = Rad_0 \subset Rad_1 \subset \dots \subset Rad_n \subset \dots \quad (4)$$

Thus, the constructor  $Rad$  has the form

$$Rad r = (Rad a) + (Rad b) * \sqrt{Nat p} | (Rad q) \quad (5)$$

Note that sequence of extensions (4) is a sequence of finite algebraic extensions of fields with roots of polynomials  $x^2 - p_n = 0$ .

Representation (5) includes a description of basic elements  $Rad q$  and a description of the extension mechanism - the constructor  $(Rad a) + (Rad b) * \sqrt{Nat p}$ . This specification exactly corresponds to the definition (4). On the other hand, the basic element description is unnecessary if it can be got from the embedding. Indeed, the specification of the  $LinComb$  vector space with the inclusion of the item describing of the elements of the basic algebra  $LinMonom$  has the form

$$LinComb w = (LinMonom u) + (LinComb w) | (LinMonom u)$$

However, the inclusion  $LinMonom \subset LinComb$  is defined by the equality  $u + 0 = u$ . Therefore a separate description  $LinMonom u$  is unnecessary. We admit both types of specifications.

Formula (4) can be directly generalized to arbitrary dynamic extensions. If an algebra  $B$  is a dynamic extension of the algebra  $A$  with the constructor  $B = \varphi(A_1, \dots, B, \dots, A_n)$ , the increasing sequence  $B_0 \subset B_1 \subset \dots \subset B_n \subset \dots$  is defined as follows:

$$B_{(0)} = A, \quad (6)$$

$$B_{(n+1)} = \varphi(A_1, \dots, B_{(n)}, \dots, A_n) \quad (7)$$

The embedding  $Red : A \rightarrow B$  defines the embedding  $Red_i : B_{i+1} \rightarrow B_i$ , from which one obtains a representation of  $A$  in the form of an increasing sequence of algebras, where each one is a static extension of the previous one.

$$B = \bigcup_{n=0}^{\infty} B_n, B_0 \subset B_1 \subset \dots \subset B_n \subset \dots \quad (8)$$

In MAS development practice there were some generalizations of the definition (8). Namely, instead of the sequence of algebras  $\{B_i\}_{i=0}^{\infty}$  let consider the set of indexed algebras  $\{A_i\}_{i \in I}$ , where  $I$  is a linearly ordered set of indices. An algebra  $B_J, J \subset I, |J| < \infty$

is defined as a union of algebras  $A_j$ ,  $j \in J$ :  $B_J = \bigcup_{j \in J} A_j$ . Let us assume there is an embedding of algebras  $B_j$ , where  $B_{J_1} \cup B_{J_2} \subset B_{J_1 \cup J_2}$ . Then

$$B = \bigcup_{J \subset I, |J| < \infty} B_J \quad (9)$$

An example of such algebra is a ring  $K[[x]]$ , the elements of which are sums of monomial with rational degrees:

$$K[[x]] = \{P: P = \sum_{j \in J, J \subset \text{Rat}, |J| < \infty} a_j x^j\} \quad (10)$$

Dynamic extensions are sequences of static extensions. This allows one to use the general scheme of implementation of dynamic extensions to derive the appropriate rewriting systems.

## 2.2 Synthesis of algebraic programs

### 2.2.1. Example of an algebraic program output with sort specifications

**Example 7.** Below is a specification of *Rat* sort and a derivation of calculations with rational numbers. Specifications of the *Rat* sort determine this sort as a field, linear order and static extension of *Int*.

```

Sort Rat:: Field, LinOrd;      //Inherited
Constructor
Rat r = { (Int a) // (Nat b); // Sort constructor
  a // 1 = a;           // The embedding function RatToInt
  Num(r) = a, Den(r) = b; // Access functions
  GCD(a, b) = 1       // Contextual condition
  Form: Num(Form(r)) ∈ Int, Den(Form(r)) ∈ Nat,
  GCD(Num(Form(r)), Den(Form(r))) = 1;
};
Operations
Add: a//b + c//d = Form((a*d + b*c) // (b*d));
Sub: a//b - c//d = Form((a*d - b*c) // (b*d));
Mult: a//b * c//d = Form((a*c) // (b*d));
Div: a//b / c//d = Form((a*d) // (b*c));
Div: a/b = Form(a//b), a/0 = Exception('Divison by zero');
Pow: n >= 0 -> (a//b)^n = (a^n//b^n),
n < 0 -> (a//b)^n = (b^-n//a^-n);
Predicates
Equ: a//b == c//d = (a == c) & (b == d);
Gre: a//b > c//d = (a*d > b*c);
Les: a//b < c//d = (a*d < b*c);
UnLes: a//b >= c//d = (a//b > c//d) ∨ (a//b == c//d);
UnGre: a//b <= c//d = (a//b < c//d) ∨ (a//b == c//d);

```

Consider the output of the *Add* operation interpreter. From specifications we have:

$$a//b + c//d = \text{Form}((a*d + b*c)//(b*d)); \quad (11)$$

$$a//1 = a; \quad (12)$$

we get:

$$a + c//d = \text{Form}((a*d + 1*c)//(1*d)); \quad (13)$$

Applying the sort equality  $\text{Int } a*1 = 1*a = a$  to (13), we obtain:

$$a + c//d = \text{Form}((a*d + c)//d) \quad (14)$$

Similarly, for the second operand:

$$a//b + c = \text{Form}((a + b*c)//b);$$

The resulting relations are particular cases of (12) - a specification of the *Add* operation with the *RatToInt* embedding. Together with the general relation (11) they define implementation rules for addition of fractions:

```
Add:=rs{
a//b + c//d = Form((a*d + b*c), (b*d)),
a + c//d = (a*d + c)//d,
a//b + c = (a + b*c)//b
};
```

Similarly interpreters of operations of subtraction and multiplication on *Rat* can be derived. An exception is the division operation, which is absent in the signature of *Int* sort. Therefore, it is necessary to define and specify it as multi-sorted (see specification of the *Rat* sort). Another exception is the exponentiation operation, which is expressed using multiplication.

Now let us focus on the *Form* function. Definition of this function connects it with the symbol of sort constructor. The role of this function is essentially in the canonization of sort element. During execution of a rule of the general form this function is called on the result of the operation. Therefore, *Form* is an interpreter of the constructor sort symbol. For the symbol *//* of *Rat* sort constructor we will use the notation *!//*. The general rule of addition will take the form

$$a//b + c//d = a*d + b*c)!/(b*d).$$

We will always include the sign “!” in the infix notation of sorts constructors and it will always mean the call of the constructor of sort interpreter.

```
Add:=rs{
a//b + c//d = (a*d + b*c)!/(b*d),
a + c//d = (a*d + c)//d,
a//b + c = (a + b*c)//b
};
```

Interpreter of sort constructor is called only in the first rule.



The method of derivation of an interpreter of an operation of sort  $v$  from its specification in the case when the algebra  $A_v$  is defined as a static extension of algebra  $A_u$  can be generalized as an algorithm of synthesis of an algebraic program.

Note that this method can be implemented in the form of an algebraic program because it relies only on equational derivation. For automation of elimination of the *Form* functions more sophisticated methods and technologies have to be used, e.g. a theorem prover over the basic sort  $u$ .

### 2.2.2 Interpreters output in linear dynamic extensions

**Example 8.** Specifications of *Polynom* sort and calculations with univariate polynomials.

Specifications of the *Polynom* sort define this sort as a Euclidean domain and a linear dynamic extension of *Monom*.

```

Sort Polynom::EuclideanDomain;
Parameter Field Coef, Const Variable Argument;
Constructor{
Polynom P = Monom M ++ Polynom Q // Constructor of sort
0 ++ P = P, //Embedding function PolynomToPolynom
M ++ 0 = M; //Embedding function PolynomToMonom
LeadMon(P) = M, // Access functions
LeadCoef(P) = Cf(M),
Arg(P) = Arg(M), Deg(P) = Deg(M);
Deg(M) > Deg(Q), Arg(M) = Arg(Q); //Contextual condition
Form: M ∈ Monom, Q ∈ Polynom,
0 ++ P = P, M ++ 0 = M,
Arg(M) = Arg(Q), Deg(M) > Deg(Q), Cf(M) <> 0
};
Operations
Add: Deg(a) == Deg(b) → (a++A)+(b++B)=(a+b) !+ (A+B); (15)
Sub: Deg(a) == Deg(b) → (a++A)-(b++B)=(a-b) !+ (A-B);
Mult: // Polynom * Polynom → Polynom; Commutative
(a++A)*(b++B)=(a*b)++((a*B+A*b)+A*B);
Mult: // Coef * Polynom → Polynom; Commutative
c*(b++B)=c*b ++ c*B;
(b++B)*c = Form(c*b, c*B);
Div: (a++A)/b = a/b ++ A/b;
Pow: a^n=sqr(a^n div 2)*a^(n mod 2); // From sort
MiltSemiGroup
IntDiv:
Deg(P) == Deg(Q) → P div Q = LeadCoef(P)/LeadCoef(Q),
Deg(P) < Deg(Q) → P div Q = 0,
Deg(P) > Deg(Q) → P div Q = LeadMon(P)div LeadMon(Q)++
P-(LeadMon(P)div LeadMon(Q))*Q div Q);
Mod: P mod Q = P - (P div Q)*Q; // From EuclideanDomain

```

In this example, we show that the methods of derivation of specifications discussed above leads to mathematically sound systems of interpretation rules.

First of all, note that there are two fundamentally different methods of definition operations. Operations *Add*, *Sub*, *Mult*, *Div* are defined in terms of constructors of operands. Such a definition of operation will be called constructive. It demonstrated by the definition of the operation *IntDiv* (division with remainder). *Mod* operation is defined in terms of operations of signatures *Polynom* sort. We will call such definitions of operations abstract or derived. Since this signature is inherited from the abstract sort *EuclideanDomain*, the specification of *Mod* is given in this sort. In *EuclideanDomain* sort Euclidean algorithm is defined. *Pow* operation should be defined earlier – in specification of the sort *MultSemiGroup*.

A constructor of a sort is defined recursively. So the *Polynom* algebra is a sequence of nested algebras which begins with the algebra *Monom* (Monoms of one variable):

$$Mon = Pol_0 \subset Pol_1 \subset \dots \subset Pol_k \subset \dots \quad (16)$$

The algebra  $Pol_i$  is a set of polynomials of  $i$ -th degree. Then  $Pol_i$  is a vector space of dimension  $i + 1$ . In this interpretation polynomial degree determines the index in the sequence. Therefore, the operation of addition *Add* (15) is determined by three equalities, the first of which defines the rule of addition, if both operands belong to one algebra, the other two – when they belong to different algebras:

$$a, b \in Pol_i; a \in Pol_i, b \in Pol_j, i < j; a \in Pol_i, b \in Pol_j, i > j$$

Thus, the extension (16) is an extension of vector spaces. The rules of interpretation of vector operations are derived from their specifications quite similar to the case of static extensions:

$$\dim(Pol_i) = i + 1, \dim(Pol_{i+1}) = i + 2, Pol_i \subset Pol_{i+1},$$

$$V \in Pol_{i+1} \rightarrow V = a ++ A, A \in Pol_i; 0 ++ A = A, a ++ 0 = a.$$

$\text{Deg}(a) == \text{Deg}(b) \rightarrow (a ++ A) + (b ++ B) = (a + b) !+ (A + B),$  //basic rule  
 $\text{Deg}(A) < \text{Deg}(b) \rightarrow A + (b ++ B) = b !+ (A + B),$  //partial cases  
 $\text{Deg}(a) > \text{Deg}(B) \rightarrow (a ++ A) + B = a !+ (A + B)$

The derived rules still do not consider the second of the conditions  $\mathbf{M} ++ \mathbf{0} = \mathbf{M}$ . Therefore, each of these rules should still be converted:

$$\text{Deg}(a) == \text{Deg}(b) \rightarrow a + (b ++ B) = (a + b) !+ B.$$

$$\text{Deg}(a) == \text{Deg}(b) \rightarrow (a ++ A) + b = (a + b) !+ A.$$

So, for the *Add* operation of sort *Polynom* we obtain the following system of rules:

$$\text{Deg}(a) == \text{Deg}(b) \rightarrow (a ++ A) + (b ++ B) = (a + b) !+ (A + B),$$

$$\text{Deg}(a) == \text{Deg}(b) \rightarrow a + (b ++ B) = (a + b) !+ B,$$

$$\text{Deg}(a) == \text{Deg}(b) \rightarrow (a ++ A) + b = (a + b) !+ A,$$

$$\text{Deg}(A) < \text{Deg}(b) \rightarrow A + (b ++ B) = b !+ (A + B),$$

$$\text{Deg}(A) < \text{Deg}(b) \rightarrow A + b = b ++ A,$$

$$\text{Deg}(a) > \text{Deg}(B) \rightarrow (a ++ A) + B = a !+ (A + B),$$

$$\text{Deg}(a) > \text{Deg}(B) \rightarrow a + B = a ++ B;$$

Also on the sort *Monom* we define an additional partial operation *Add*:

$$a\$x + b\$x = (a + b) \$x.$$

This system takes into account both conditions, i.e. of a sequence of extensions

$$Monom = Pol_0 \subset Pol_1, Pol_i \subset Pol_{i+1}$$

**Conclusion.** Specifications of the sort *Polynom* determine a dynamic extension of the vector space. Derived operations should be excluded from the specifications of *Polynom* and included in specifications of the relevant abstracted algebras. Constructive operations of the signature of vector space are defined by the main case. The special cases are derived by the methods of derivation of static extensions.

Because there are two embedding relations for the sort *Polynom*, the derivation of a complete rules system is done sequentially: firstly by the first relation and then by the second one. Multiplication and an incomplete division are specified separately as additional operations on the vector space *Polynom*.

### 2.2.3 Example of algebraic program output within sort specifications. Dynamic binary extension

Consider an example of a binary dynamic extension of the Bool algebra – the algebra of logic *BoolAlg* [14]. This algebra is an extension of the *Variable* base sort, because the elements of sort are Latin letters interpreted as logical formulas. We will show that derivation of interpreters of logical operations is performed by the same methods.

The elements of the set *BoolAlg* are formulas of the propositional logic of many variables. Let  $F(x_1, x_2, \dots, x_n)$  be an arbitrary formula of propositional logic of  $n$  variables. Denote as  $O$  and  $I$  the truth and falsity values respectively. Then

$$F(x_1, x_2, \dots, x_n) = x_n \& F(x_1, x_2, \dots, x_{n-1}, I) \vee \neg x_n \& F(x_1, x_2, \dots, x_{n-1}, O).$$

If we denote

$$A(x_1, \dots, x_{n-1}) = F(x_1, \dots, x_{n-1}, I), B(x_1, \dots, x_{n-1}) = F(x_1, \dots, x_{n-1}, O),$$

we obtain the representation

$$F(x_1, x_2, \dots, x_n) = x_1 \& A(x_1, \dots, x_{n-1}) \vee \neg x_1 \& B(x_1, \dots, x_{n-1}) \quad (17)$$

Now perform sequentially the same transformations of formulas  $A, B$  w.r.t. the variables  $x_{n-1}, \dots, x_n$ . As a result we obtain a recursive representation of the propositional logic formulas. Indeed, through *BoolAlg<sub>m</sub>* denote the set of propositional logic formulas in variables  $x_1, \dots, x_m$ . Then

$$BoolAlg_n = \{F : F = x_n \& A \vee \neg x_n \& B, A, B \in BoolAlg_{n-1}\}$$

Thus, sort *BoolAlg* is the union of an increasing sequence of algebras *BoolAlg<sub>m</sub>*:

$$BoolAlg_0 = Bool, BoolAlg_0 \subset BoolAlg_1 \subset \dots \subset BoolAlg_m \subset \dots \quad (18)$$

$$BoolAlg = \cup BoolAlg_m$$

Note that formula (17) defines a canonical form of a formula of the algebra of propositions. Denote

$$BF(A, B, x) \stackrel{df}{=} x \& A \vee \neg x \& B \quad (19)$$

Then

$$BF(A_1, B_1, x) \& BF(A_2, B_2, x) = BF(A_1 \& A_2, B_1 \& B_2, x), \quad (20)$$

$$BF(A_1, B_1, x) \vee BF(A_2, B_2, x) = BF(A_1 \vee A_2, B_1 \vee B_2, x) \quad (21)$$

$$\neg BF(A, B, x) = BF(\neg A, \neg B, x). \quad (22)$$

Thus, the basic logic operations are performed per the argument! Finally, it is easy to check that the embedding function is defined by the equality

$$BF(A, A, x) = A \quad (23)$$

## Conclusion

In this paper we have shown that the concept of a constructive extension of MAS is the key one in design and implementation of symbolic computations. Most of all, this applies to symbolic computations in mathematical systems for educational purposes, where classical algebras and algebraic systems are used.

Actually, the constructive approach, along with the axiomatic approach in algebra is well known [12-13]. The idea of a constructive definition of an algebra element through the elements of basic algebras is systematically used in algebraic research. On the other hand, the overloading mechanism for algebraic operations is a standard tool in programming of mathematical systems.

Thus, the main theoretical result is the idea of systematic usage of the construct of extension in programming of MAS signatures as overloaded signatures. Other methodical components of proposed approach are given in [14-17].

The practice of usage of this approach in development of mathematical systems for education has shown its effectiveness and even universality. This is the main practical result.

## References

1. Lvov, M., Kuprienko, A., Volkov, V.: Applied Computer Support of Mathematical Training. Proceedings of Internal Workshop in Computer Algebra Applications. 25-26. Kiev. (1993).
2. Lvov, M.: AIST: Applied Computer Algebra System. Proceedings of ICCTE'93. 25-26. Kiev. (1993).

3. Lvov, M.: Therm VII - school computer algebra system. *Computer in school and family*. 7, 27-30 (2004).
4. Letichevsky, A., Kapitonova, J., Volkov, V., Chugajenko, A., Chomenko, V.: Algebraic programming system APS (user manual). Glushkov Institute of Cybernetics, National Academy of Sciences of Ukraine, Kiev (1998).
5. Kapitonova, J., Letichevsky, A., Volkov, V.: Deductive means of the system of algebraic programming. *Cybernetics and system analysis*. 1, 17–35 (2000).
6. Kapitonova, J., Letichevsky, A., Lvov, M., Volkov, V.: Tools for solving problems in the scope of algebraic programming. *Lectures Notes in Computer Sciences*. 958, 31-46 (1995).
7. Lvov, M.: Basic principles of constructing pedagogical software to support practical classes. *Control systems and machines*. 6, 70-75 (2006).
8. Peschanenko, V.: Extending standard modules algebraic programming system APS for use in systems for educational purposes. *Scientific journal of the National Pedagogical University named after M.P. Drahomanov*. 3 (10), 206-215 (2005).
9. Peschanenko, V.: About one approach to the design of algebraic data types. *Problems of programming (Problemy prohramuvannia)*. 2-3, 626-634 (2006).
10. Peschanenko, V.: Use of the algebraic programming system APS to build systems for supporting the study of algebra in school. *Upravlyayuschie sistemy i mashiny (Control systems and machines)*. 4, 86-94 (2006).
11. Van der Varden, B: Algebra. Nauka, Moscow (1979).
12. Goguen, J., Meseguer, J.: Ordered-Sorted Algebra I: Partial and Overloaded Operations. Errors and Inheritance. Technical Report, SRI International, Computer Science Lab (June 1983).
13. Goguen J.A., Meseguer J. (1987) Models and equality for logical programming. In: Ehrig H., Kowalski R., Levi G., Montanari U. (eds) TAPSOFT '87. TAPSOFT 1987. Lecture Notes in Computer Science, vol 250. Springer, Berlin, Heidelberg
14. Lvov, M.: About one approach to the implementation of algebraic calculations: calculations in the algebra of statements. *Bulletin of Kharkiv National University (Series "Mathematical Modeling. Information Technology. Automated Control Systems")*. 863, 157-168 (2009).
15. Lvov, M.: About one approach to verification of algebraic calculations. *Problems of programming*. 4, 23-35 (2011).
16. Lvov, M.: Inheritance method for the implementation of algebraic calculations in mathematical systems of educational purpose. *Systems of control, navigation and communication*. 3(11), 120-130 (2009).
17. Lvov, M.: The method of morphisms of the implementation of algebraic calculations in mathematical systems of educational purpose. *Information processing systems*. 6(80), 183-190 (2009).

# On Some Classes of Problems on Graphs

Volodymyr G. Skobelev<sup>1,2</sup>[0000–0002–7018–2319]

<sup>1</sup> Glushkov Institute of Cybernetics of NAS of Ukraine,  
Glushkov Ave., 40, Kyiv, 03187, Ukraine

<sup>2</sup> Institute of Applied Mathematics and Mechanics of NAS of Ukraine,  
Gen. Batjuk Str., 19, Donetsk Region, Slov’jansk, 84116, Ukraine  
[skobelevvg@gmail.com](mailto:skobelevvg@gmail.com)

**Abstract.** The relevance to research the complexity of resolving Graph Theory problems is caused by its numerous applications. In the given paper this problem is investigated in terms of space complexity of data structures that represent analyzed graphs, orgraphs, and directed graphs. The following two non-trivial the simplest sets of problems of Graph Theory are investigated in detail. The first set consists of the problems that can be resolved by some algorithm with space complexity linear relative to the size of the data structure that represents the analyzed graphs. The second set consists of the following problems, such that the size of the solution significantly exceeds the size of the input data. To resolve the problem some algorithm that operates on space linear relative to the size of the data structure that represents the analyzed graphs can be applied. Besides, this algorithm uses some memory of the same size for sequential generation, one fragment after another, the solution of the problem. Some model problems that are not in these two sets of problems are considered briefly.

**Keywords:** Graphs · Algorithms · Complexity.

## 1 Introduction

At present finite graphs (i.e. ordinary graphs, orgraphs, and directed graphs) are used as mathematical models in resolving a wide class of theoretic and applied problems. Rather new areas for application of Graph Theory models are computer and social networks, agent-based technologies, and transition systems used for verification of the developed software. Therefore, analysis of the complexity for algorithms on graphs is an actual problem from the theoretic and applied point of view. In Algorithms Theory, the main attention is paid to the analysis of time complexity, while many questions for space complexity remain obscure.

The aim of the given paper is to investigate the classification of Graph Theory problems in terms of the memory size necessary to represent the analyzed graphs by basic data structures. These data structures are vertices-adjacency matrices, edges-adjacency matrices, vertices-adjacency lists, and edges-adjacency lists. The main ratios for the complexity of these data structures are established in terms "for almost all" and "on average".

Two sets of Graph Theory problems are investigated in detail.

The first set consists of the problems that can be resolved by some algorithm with space complexity linear relative to the size of data structure that represents the analyzed graphs. For these problems, the memory size necessary to represent the solution is also bounded above by some linear function of the memory size necessary to represent the input data.

The second set consists of the problems that satisfy the following three conditions.

Firstly, the memory size necessary to represent the solution significantly exceeds the memory size necessary to represent the input data.

Secondly, to resolve the problem some algorithm that operates on space linear relative to the size of data structure that represents the analyzed graphs can be applied.

Thirdly, this algorithm uses some memory of the same size to generate sequentially, one fragment after another, the solution of the problem in the explicit form.

Some problems of Discrete Mathematics and its applications that can be naturally reformulated in Graph Theory terms, and that are not in the investigated two sets of problems are briefly considered.

The basic concepts used in the given paper are the same as in [1-3].

## 2 Mathematical Background

In the given Section the basic concepts and definitions necessary for the presentation of the main results are introduced.

### 2.1 Data Structures for Graphs Representation

It is well-known that the main data structures used for representations of graphs are matrices of adjacency (either vertices or edges), incidence matrices, and lists of adjacency (either vertices or edges). We denote  $\mathbf{R}$  any of these data structures.

Let  $\mathbf{G}(n, m)$ ,  $\vec{\mathbf{G}}^{or}(n, m)$ , and  $\vec{\mathbf{G}}^{dir}(n, m)$  be the set of all graphs, orgraphs and directed graphs  $G = (V, E)$  such that  $V = \{1, \dots, n\}$  and  $|E| = m$ ,  $\mathbf{R}(G)$  be the representation of  $G \in \mathbf{X}(n, m)$  ( $\mathbf{X} \in \{\mathbf{G}, \vec{\mathbf{G}}^{or}, \vec{\mathbf{G}}^{dir}\}$ ) by the data structure  $\mathbf{R}$ , and  $v(\mathbf{R}(G))$  be the size of memory necessary for the representation  $\mathbf{R}(G)$ . We set

$$v(\mathbf{R}, \mathbf{X}, n, m) = \max_{G \in \mathbf{X}(n, m)} V(\mathbf{R}(G)) \quad (\mathbf{X} \in \{\mathbf{G}, \vec{\mathbf{G}}^{or}, \vec{\mathbf{G}}^{dir}\}).$$

Due to the traditional approach in the Algorithms Theory, we will deal with asymptotic space complexity  $V(\mathbf{R}, \mathbf{X}, n, m)$  of  $v(\mathbf{R}, \mathbf{X}, n, m)$ .

It is well-known that for all  $\mathbf{X} \in \{\mathbf{G}, \vec{\mathbf{G}}^{or}, \vec{\mathbf{G}}^{dir}\}$ :

$V(\mathbf{R}, \mathbf{X}, n, m) = O(n^2)$  ( $n \rightarrow \infty$ ), if  $\mathbf{R}$  is the vertices-adjacency matrix;

$V(\mathbf{R}, \mathbf{X}, n, m) = O(m^2)$  ( $m, n \rightarrow \infty$ ), if  $\mathbf{R}$  is the edges-adjacency matrix;

$V(\mathbf{R}, \mathbf{X}, n, m) = O(mn)$  ( $m, n \rightarrow \infty$ ), if  $\mathbf{R}$  is the incidence matrix;

$V(\mathbf{R}, \mathbf{X}, n, m) = O(\max\{m, n\})$  ( $m, n \rightarrow \infty$ ), if  $\mathbf{R}$  are the vertices-adjacency lists;

$V(\mathbf{R}, \mathbf{X}, n, m) = O(m \cdot \max\{1, \min\{m, n\}\})$  ( $m, n \rightarrow \infty$ ), if  $\mathbf{R}$  are the edges-adjacency lists.

Since  $\mathbf{X}$  is a dummy variable in  $V(\mathbf{R}, \mathbf{X}, n, m)$ , we will write  $V(\mathbf{R}, n, m)$ .

Let  $v_{\mathcal{A}}(\mathbf{R}, \mathbf{X}, G)$  ( $\mathbf{X} \in \{\mathbf{G}, \vec{\mathbf{G}}^{or}, \vec{\mathbf{G}}^{dir}\}$ ) be the size of memory necessary for an algorithm  $\mathcal{A}$  to carry out the given processing of the data structure  $\mathbf{R}(G)$  ( $G \in \mathbf{X}(n, m)$ ) and

$$v_{\mathcal{A}}(\mathbf{R}, \mathbf{X}, n, m) = \max_{G \in \mathbf{X}(n, m)} v_{\mathcal{A}}(\mathbf{R}, \mathbf{X}, G).$$

In what follows, we will deal with asymptotic space complexity  $V_{\mathcal{A}}(\mathbf{R}, \mathbf{X}, n, m)$  of  $v_{\mathcal{A}}(\mathbf{R}, \mathbf{X}, n, m)$ .

## 2.2 Some Classes of Problems in Graph Theory

Let's distinguish the following set of algorithms on graphs.

**Definition 1.** *An algorithm  $\mathcal{A}$  is called a local algorithm on the set  $\mathbf{X}(n, m)$  ( $\mathbf{X} \in \{\mathbf{G}, \vec{\mathbf{G}}^{or}, \vec{\mathbf{G}}^{dir}\}$ ) and the data structure  $\mathbf{R}$ , if*

$$V_{\mathcal{A}}(\mathbf{R}, \mathbf{X}, n, m) = V(\mathbf{R}, n, m) \quad (n \rightarrow \infty, m \rightarrow \infty). \quad (1)$$

*Example 1.* Let  $\mathbf{X} = \mathbf{G}$  and  $\mathbf{R}$  be the representation of a graph  $G \in \mathbf{G}(n, m)$  by the vertices-adjacency matrix. It can be proved that the problem of checking the validity of the property "to be a connected graph" can be solved by some local algorithm.

It is evident that the validity of equality (1) can significantly depend on the law of the growth  $m \rightarrow \infty$ . To avoid this dependence, we will act as follows.

For any fixed positive integer  $n$  we set

$$\mathbf{X}(n) = \bigcup_m \mathbf{X}(n, m), \quad (2)$$

$$V_{\mathcal{A}}(\mathbf{R}, \mathbf{X}, n) = \max_m V_{\mathcal{A}}(\mathbf{R}, \mathbf{X}, n, m), \quad (3)$$

and

$$V(\mathbf{R}, n) = \max_m V(\mathbf{R}, n, m), \quad (4)$$

where union and maximum are over all admissible values of  $m$ .

On the base of formulae (2)-(4) we get the following definition.



**Definition 2.** An algorithm  $\mathcal{A}$  is called a local algorithm on the set  $X(n)$  ( $X \in \{G, \vec{G}^{or}, \vec{G}^{dir}\}$ ) and the data structure  $R$  for any admissible law of the growth  $m \rightarrow \infty$ , if

$$V_{\mathcal{A}}(R, X, n) = V(R, n) \quad (n \rightarrow \infty).$$

*Example 2.* Let  $X = G$ . It can be proved that following three statements are true:

1. Let  $R$  be the representation of a graph  $G \in G(n, m)$  either by the vertices-adjacency matrix, or by the vertices-adjacency lists. Then the problem of checking the validity of the property "the given two graphs are isomorphic" can be solved by some algorithm that is a local algorithm for any admissible law of the growth  $m \rightarrow \infty$ .

2. Let  $R$  be the representation of a graph  $G \in G(n, m)$  either by the vertices-adjacency matrix, or by the edges-adjacency matrix. Then the problem of checking the validity of the property "some sub-graphs of the given graph are the triangles" can be solved by some algorithm that is a local algorithm for any admissible law of the growth  $m \rightarrow \infty$ .

3. Let  $R$  be the representation of a graph  $G \in G(n, m)$  by the vertices-adjacency matrix. Then the problem of checking the validity of the property "to be a bipartite graph", and each of the problems of computing for the given graph  $G \in G(n, m)$  the radius, the diameter, the center, and the connected components can be solved by some algorithm that is a local algorithm for any admissible law of the growth  $m \rightarrow \infty$ .

On the base of Definition 2, we can distinguish the following set of Graph Theory problems.

**Definition 3.** The set  $Lcl(R, X)$  ( $X \in \{G, \vec{G}^{or}, \vec{G}^{dir}\}$ ) is the set of all Graph Theory problems  $P$ , such that the problem  $P$  can be resolved by some local algorithm on the set  $X(n)$  and the data structure  $R$  for any admissible law of the growth  $m \rightarrow \infty$ .

*Example 3.* 1. Let  $A_n$  ( $n = 1, 2, \dots$ ) be the algebraic system with the basic set

$$G(n) = \bigcup_{m \geq 0} G(n, m),$$

the set of operations

$$F_{op}^{A_n} = \{\setminus, \cup, \cap, \oplus, \neg\},$$

and the set of relations

$$F_{rel}^{A_n} = \{=, \subset\}.$$

It can be proved that in the algebraic system  $A_n$  the problems of implementation of any operation  $f \in F_{op}^{A_n}$  and checking the validity of any relation  $\rho \in F_{rel}^{A_n}$  are elements of the set  $Lcl(R, G)$  for any data structure  $R$ .

2. Let  $B$  be the algebraic system with the basic set

$$T = \bigcup_{n=1}^{\infty} G(n),$$

the set of operations

$$F_{op}^B = \bigcup_{n=1}^{\infty} F_{op}^{A_n} \cup \{\circ, \rightarrow, \bullet, *, \wedge, \vee\},$$

and the set of relations

$$F_{rel}^B = \bigcup_{n=1}^{\infty} F_{rel}^{A_n} \cup \{\leq, \triangleleft\}.$$

It can be proved that for the algebraic system  $B$  the following two statements are true:

1. The problems of implementation of any operation  $f \in \{\circ, \rightarrow\}$  and checking the validity of any relation  $\rho \in \{\leq, \triangleleft\}$  are elements of the set  $Lcl(R, G)$  for any data structure  $R$ .

2. For each operation  $f \in \{\bullet, *, \wedge, \vee\}$  the problem of its implementation is not an element of the set  $Lcl(R, G)$  for any data structure  $R$ .

*Remark 1.* The operations  $\vee$  and  $\wedge$  are often used in the design and analysis of algorithms. In particular, for parallel and concurrent computing. Indeed, let the graphs  $G_1, G_2 \in T$  be the models of the two given sub-problems. The vertices present the separate stages of solving these problems, and the edges specify what stages are the neighbors.

The graph  $G_1 \wedge G_2$  describes the situation when only simultaneous advance on stages of both sub-problems is admissible.

The graph  $G_1 \vee G_2$  describes the situation when advance on stages at least of one of the sub-problems is admissible.

For a wide class of Graph Theory problems the size of the solution significantly exceeds the size of the input data. Due to this situation, it is reasonable to distinguish the following set of Graph Theory problems.

**Definition 4.** *The set  $P$ -Work-Space( $R, X$ ) ( $X \in \{G, \vec{G}^{or}, \vec{G}^{dir}\}$ ) is the set of all Graph Theory problems  $P$ , such that the problem  $P$  can be resolved on the set  $X(n)$  and the data structure  $R$  for any admissible law of the growth  $m \rightarrow \infty$  by some algorithm  $A$  that satisfies to the following two conditions:*

*Condition 1.* *The algorithm  $A$  operates on the memory size  $V(R, n)$  ( $n \rightarrow \infty$ ).*

*Condition 2.* *The algorithm  $A$  explores as an output channel some additional memory of the size that is a polynomial of  $V(R, n)$  to generate the solution sequentially, one fragment after another.*

We denote  $\text{Work-Lcl}(\mathbf{R}, \mathbf{X})$  the set of all problems  $P \in \text{P-Work-Space}(\mathbf{R}, \mathbf{X})$ , such that the size of additional memory, pointed in Condition 2 of Definition 4 is a linear polynomial of  $V(\mathbf{R}, n)$ . It can be proved that for any  $\mathbf{X} \in \{\mathbf{G}, \vec{\mathbf{G}}^{or}, \vec{\mathbf{G}}^{dir}\}$  and any data structure  $\mathbf{R}$  the following strict inclusions hold

$$\text{Lcl}(\mathbf{R}, \mathbf{X}) \subset \text{Work-Lcl}(\mathbf{R}, \mathbf{X}) \subset \text{P-Work-Space}(\mathbf{R}, \mathbf{X}).$$

*Example 4.* It can be proved that the following three statements are true:

1. Let  $\mathbf{R}$  be the representation either by the vertices-adjacency matrix, or by the vertices-adjacency lists. Then the problem of the design of the edge-to-vertex dual graph is an element of the set  $\text{Work-Lcl}(\mathbf{R}, \mathbf{G}) \setminus \text{Lcl}(\mathbf{R}, \mathbf{G})$ .

2. The problem of the design of some the longest path between the two given vertices in a graph  $G \in \mathbf{G}(n)$ , and consequently, the problem of the design of the set of all longest paths between the two given vertices in a graph  $G \in \mathbf{G}(n)$ , are elements of the set  $\text{Work-Lcl}(\mathbf{R}, \mathbf{X}) \setminus \text{Lcl}(\mathbf{R}, \mathbf{X})$  for any data structure  $\mathbf{R}$ .

3. In the algebraic system  $B$  (see example 3.2), the problem of implementation of any operation  $f \in \{\bullet, *, \wedge, \vee\}$  is an element of the set  $\text{Work-Lcl}(\mathbf{R}, \mathbf{G}) \setminus \text{Lcl}(\mathbf{R}, \mathbf{G})$  for any data structure  $\mathbf{R}$ .

### 3 Analysis of Graphs Representations

Similarly to the algebraic systems  $A_n$  ( $n = 1, 2, \dots$ ) and  $B$  (see example 3), there can be defined the algebraic system  $\vec{A}_n^{or}$  ( $n = 1, 2, \dots$ ) with the basic set  $\vec{\mathbf{G}}^{or}(n)$ , the algebraic system  $\vec{B}^{or}$  with the basic set

$$\vec{\mathbf{T}}^{or} = \bigcup_{n=1}^{\infty} \vec{\mathbf{G}}^{or}(n),$$

the algebraic system  $\vec{A}_n^{dir}$  ( $n = 1, 2, \dots$ ) with the basic set  $\vec{\mathbf{G}}^{dir}(n)$ , and the algebraic system  $\vec{B}^{dir}$  with the basic set

$$\vec{\mathbf{T}}^{dir} = \bigcup_{n=1}^{\infty} \vec{\mathbf{G}}^{dir}(n).$$

In Subsection 2.2, when we were speaking about complexity, we meant "complexity in the worst case". From the theoretic and applied point of view, both, a significant role also play "the average-case complexity" and "complexity for almost all input data".

The following factors form the strong base for the application of this approach for the detailed analysis of complexity for problems formulated in terms of the algebraic systems  $Y_n$  ( $Y \in \{A, \vec{A}^{or}, \vec{A}^{dir}\}$ ) and  $Z$  ( $Z \in \{B, \vec{B}^{or}, \vec{B}^{dir}\}$ ).

On the base of standard methods used for computing the mathematical expectation of the random variable defined on a finite set, the following theorem can be proved.

**Theorem 1.** Let  $X \in \{G, \vec{G}^{or}, \vec{G}^{dir}\}$ . For chosen randomly element of the set  $X(n)$  the average number of edges equals to:

- 1)  $0.25n(n-1)$ , if  $X = G$ ;
- 2)  $\frac{1}{3}n(n-1)$ , if  $X = \vec{G}^{or}$ ;
- 3)  $0.5n(n-1)$ , if  $X = \vec{G}^{dir}$ .

Proceeding from this theorem, the following two propositions can be proved.

**Proposition 1.** Let the elements of the basic set  $X(n)$  ( $X \in \{G, \vec{G}^{or}, \vec{G}^{dir}\}$ ) be chosen randomly. Then in the relevant algebraic system  $Y_n$  ( $Y \in \{A, \vec{A}^{or}, \vec{A}^{dir}\}$ ) the average time for the implementation of any operation, as well as the average time for checking validity of any relation, is asymptotically the same for representations of elements of the basic set  $X(n)$  by the vertices-adjacency lists and by the vertices-adjacency matrices.

**Proposition 2.** Let the elements of the basic set  $X(n)$  ( $X \in \{G, \vec{G}^{or}, \vec{G}^{dir}\}$ ) be chosen randomly. Then in the relevant algebraic system  $Y_n$  ( $Y \in \{A, \vec{A}^{or}, \vec{A}^{dir}\}$ ) the average time for the implementation of any operation, as well as the average time for checking validity of any relation, for representations of elements of the basic set  $X(n)$  by the edge-adjacency lists is less asymptotically than the appropriate time for representations of elements of the basic set  $X(n)$  by the edges-adjacency matrices.

On the base of standard methods used for computing the variance of the random variable defined on a finite set, and using Chebyshev's inequality, the following theorem can be proved.

**Theorem 2.** Let  $X \in \{G, \vec{G}^{or}, \vec{G}^{dir}\}$ . For almost all elements of the set  $X(n)$  ( $n \rightarrow \infty$ ) the number  $m$  of edges satisfy to the following asymptotic equality

$$m = \Theta(n^2) \quad (n \rightarrow \infty).$$

Proceeding from this theorem, the following two propositions can be proved.

**Proposition 3.** In the algebraic system  $Y_n$  ( $Y \in \{A, \vec{A}^{or}, \vec{A}^{dir}\}$ ) for almost all elements of the relevant basic set  $X(n)$  ( $X \in \{G, \vec{G}^{or}, \vec{G}^{dir}\}$ ) the time for the implementation of any operation, as well as the time for checking validity of any relation, is asymptotically the same for representations of elements of the basic set  $X(n)$  by the vertices-adjacency lists and by the vertices-adjacency matrices.

**Proposition 4.** In the algebraic system  $Y_n$  ( $Y \in \{A, \vec{A}^{or}, \vec{A}^{dir}\}$ ) for almost all elements of the relevant basic set  $X(n)$  ( $X \in \{G, \vec{G}^{or}, \vec{G}^{dir}\}$ ) the time for the implementation of any operation, as well as the time checking validity of any relation, for representations of elements of the basic set  $X(n)$  by the edge-adjacency lists is asymptotically less than the appropriate time for representations of elements of the basic set  $X(n)$  by the edges-adjacency matrices.

#### 4 Some Remark About the Set $\text{Work-Lcl}(\mathbf{R}, \mathbf{X}) \setminus \text{Lcl}(\mathbf{R}, \mathbf{X})$

One of the main reason owing to which the considerable number of problems of Graph Theory are elements of the set  $\text{Work-Lcl}(\mathbf{R}, \mathbf{X}) \setminus \text{Lcl}(\mathbf{R}, \mathbf{X})$  is based on the following factor. The problem of the design of any object is an element of the set  $\text{Lcl}(\mathbf{R}, \mathbf{X})$ , but the number of objects, which are required to be designed as the solution of the analysed problem, is an exponent or some sub-exponent of  $n$  and  $m$ . This situation can be illustrated as follows.

*Example 5.* It can be proved that for all  $\mathbf{X} \in \{\mathbf{G}, \vec{\mathbf{G}}^{or}, \vec{\mathbf{G}}^{dir}\}$  and for all data structures  $\mathbf{R}$  the following problems are elements of the set  $\text{Lcl}(\mathbf{R}, \mathbf{X})$ :

1. The problem of the design of some the shortest path between the given two vertices in  $G \in \mathbf{X}(n)$ .
2. The problem of the design of some Hamiltonian path between the given two vertices in  $G \in \mathbf{X}(n)$ .
3. The problem of the design of some Hamiltonian cycle in  $G \in \mathbf{X}(n)$ .
4. The problem of the design of some cycle that visits the given vertex in  $G \in \mathbf{X}(n)$ .
5. The problem of the design of some spanning tree in  $G \in \mathbf{X}(n)$ .
6. The problem of the design of some minimum spanning tree in  $G \in \mathbf{X}(n)$ .

On the base of estimation the number of objects which can be designed in each of listed above case, it can be proved that for all  $\mathbf{X} \in \{\mathbf{G}, \vec{\mathbf{G}}^{or}, \vec{\mathbf{G}}^{dir}\}$  and for all data structures  $\mathbf{R}$  the following problems are elements of the set  $\text{Work-Lcl}(\mathbf{R}, \mathbf{X}) \setminus \text{Lcl}(\mathbf{R}, \mathbf{X})$ :

1. The problem of the design of the set of all shortest paths between the two given vertices in  $G \in \mathbf{X}(n)$ .
2. The problem of the design of the set of all Hamiltonian path between the given two vertices in  $G \in \mathbf{X}(n)$ .
3. The problem of the design of the set of all Hamiltonian cycles in  $G \in \mathbf{X}(n)$ .
4. The problem of the design of the set of all cycles that visit the given vertex in  $G \in \mathbf{X}(n)$ .
5. The problem of the design of the set of all spanning trees in  $G \in \mathbf{X}(n)$ .
6. The problem of the design of the set of all minimum spanning trees in  $G \in \mathbf{X}(n)$ .

#### 5 Out of the Set $\text{Work-Lcl}(\mathbf{R}, \mathbf{X})$

Analysis of problems pointed in the Section 4, show that each of them can be solved by backtracking with linear space complexity. Unfortunately, there is a wide class of problems of Discrete Mathematics and its applications, such that the following two conditions hold:

1. Searching is the only known method of the solution of the given problem.
2. At implementation of searching there is an essential growth of lengths and the number of the designed and analyzed sequences of objects, both (just this factor results in exponential space complexity of searching).

All these problems formulated in terms of Graph Theory are the problems that are out of the set  $\text{Work-Lcl}(\mathbb{R}, \mathbb{X})$ .

An important non-trivial subset of the above-pointed problems of Discrete Mathematics consists of the problems that can be reduced to the design of some strategy for walks of special type on some graph. This subset includes in itself the problems, at least, of the following three types:

1. The problems that can be reduced to the design some unconditional, adaptive or cooperative strategy for some walk on the given graph, intended to identify the vertices covered by blots. In particular, to these problems can be reduced problems of identification of states for finite automata. Interpretation of these adaptive and cooperative strategies in terms of automata-experimenters demonstrates high complexity for computing the values of predicates defined on graphs by some finite automaton or some interacting group of finite automata.

2. The problems that are connected with the design of the supervisor intended to carry out adaptive control for discrete events systems presented by finite automata models.

3. The problems connected with the design of the winning strategies for considerable number of two persons games on graphs.

## 6 Conclusions

In the given paper we have analyzed two sets of Graph Theory problems. The first set consists of all Graph Theory problems that can be resolved by algorithms with linear space complexity. The second set consists of all Graph Theory problems, for which the size of the solution essentially exceeds the size of the input data, but there exists some algorithm that operates on space linear relative to the size of the input data, and this algorithm uses some additional memory of the same size, intended to generate the solution sequentially, one fragment after another.

It has been illustrated that these sets consist of sufficiently wide class of Graph Theory problems.

The carried-out analysis of sufficiently powerful algebraic systems on graphs gave the possibility to establish a number of estimates in terms "in average" and "for almost all objects".

Presented in the given paper results form some strong base for research of the structure of the set  $\text{P-Work-Space}(\mathbb{R}, \mathbb{X})$ , for analysis complexity, accuracy and efficiency of local search strategies on graphs, for investigation problems of design different strategies for walks on graphs, etc.

## References

1. Harary, F.: Graph theory. Addison-Wesley Publishing Company, Inc., Reading, MA, USA (1969)
2. Aho, A.V., Hopcroft, J.E., and Ullman, J.D.: The design and analysis of computer algorithm. Addison-Wesley Longman Publishing Co., Inc., Boston, MA, USA (1975)
3. Bollobas, B.: Modern graph theory. Springer-Verlag, New York, Berlin, Heidelberg (1998)

# Extending the SMT-Lib Standard with Theory of Nominative Data

Liudmyla Omelchuk<sup>1[0000-0002-2287-1304]</sup>, Olena Shyshatska<sup>1[0000-0001-8791-8989]</sup>

<sup>1</sup> Taras Shevchenko National University of Kyiv, Akademika Hlushkova Ave, 4d,

Kyiv, 03680 Ukraine

`l.omelchuk@knu.ua`, `shyshatska@knu.ua`

**Abstract.** We describe the theory of nominative data, formulate the basic principles of the composition-nominative approach, and define the class of nominative data and functions. By using nominative data, we can increase the level of adequacy of representation data structures, functions, and compositions that are used in programming languages. Thus, in terms of composition-nominative approach, we can build systems of verification of programs based on a unified conceptual basis. Computer-aided verification of computer programs often uses SMT (satisfiability modulo theories) solvers. A common technique is to translate preconditions, postconditions, and assertions into SMT formulas in order to determine if required properties can hold. The SMT-LIB Standard was created for forming a common standard and library for solving SMT problems. Now, it is one of the most used libraries for SMT systems. Formulas in SMT-LIB format are accepted by the great majority of current SMT solvers. The theory of nominative data is of interest for software modelling and verification, but currently lacks support in the SMT-LIB format. In the article, we propose the declaration for the theory of nominative data for the SMT-LIB Standard 2.6. The goal is the development of SMT solvers with nominative data support.

**Keywords:** SMT solver, partial logic, nominative data, composition programming.

## 1 Introduction

Composition programming studies the systems at different levels of abstraction – abstract, Boolean, and nominative (attribute) levels. Systems of the last level, based on the composition-nominative methods [1], are rather expressible for a quite adequate representation of the models of data structures and programs. Thus, the composition-nominative approach provides a unified methodological basis to formalize the concept of program specification. By using nominative data, we can increase the level of adequacy of representation data structures, functions, and compositions that are used in programming languages. The axiomatic theory of nominative data [2] is developed in the spirit of the theory of admissible sets (S. Kripke, R. Platek, J. Barwise,

Yu.L. Yershov). This theory has a number of advantages with respect to the adequacy of programming: on the one hand, it is strong enough to generate computable functions over different data structures, on the other hand, it is not so restrictive as different versions of constructive logic, but it is not excessively powerful and does not allow, for example, the use of axiom of constructing the set of all subsets (compared with theory of sets by Zermelo-Frankel). Moreover, this theory uses basic data corresponding to the methods of constructing data in programming. In terms of composition-nominative approach, while using nominative data one can increase the adequacy of representation data structures, functions, and compositions used in programming languages and build the systems of program specifications based on the single conceptual framework. Basic data types of programming languages were specified in [2], in addition, the functions over nominative data were specified in [1-4].

It is therefore natural to expect program analysis and verification tools to be able to reason about programs, by means of deciding the validity of formulas containing variables of such types. Application of such tools requires a standard exchange format for these types of formulas.

Dafny [5] is one of the formal verification languages. It is a hybrid language, with functional and object-oriented features, which can automatically check programs against specifications. Behind the scenes, Dafny converts programs for its users into the mathematical expressions of Hoare logic with the aid of an intermediate verification language called Boogie, and then it sends the code to an automatic proving program called Z3 [6]. Z3 input format is an extension of the one defined by the SMT-LIB 2 standard [7, 8]. This conversion process benefits Dafny users in eliminating the need to write out long proofs in confusing notation while still being able to verify their programs. As a result, Dafny requires that programmers use a strict form of syntax in order to properly convert their code into mathematical expressions.

The standardization of formats in logic has played a major role in accelerating research in the past. Examples for successful standardization efforts are the DIMACS format for Boolean formulas in conjunctive normal form (CNF), and the SMT-LIB format [6] dedicated to various first-order theories that are used in verification.

SMT-LIB was created in 2003 with the expectation that the availability of common standards and a library of benchmarks would greatly facilitate the evaluation and the comparison of SMT (satisfiability modulo theories) systems. Now, SMT-LIB contains more than 100,000 benchmarks and continues to grow. Formulas in SMT-LIB format are accepted by the great majority of current SMT solvers.

In computer science and mathematical logic, the satisfiability modulo theories problem is a decision problem for logical formulas with respect to combinations of background theories expressed in classical first-order logic with equality. Examples of theories typically used in computer science are the theory of real numbers, the theory of integers, and the theories of various data structures such as lists, arrays, bit vectors and so on. SMT can be thought of as a form of the constraint satisfaction problem and thus a certain formalized approach to constraint programming.

The following systems (listed alphabetically) were under active development in 2018: Alt-Ergo, AProVE, Boolector, CVC4, MathSAT 5, OpenSMT 2, raSAT, SMTInterpol, SMT-RAT, STP, veriT, Yices 2, Z3 [6-8].



A new sublogic, or simply logic, is defined in the SMT-LIB language by a logic declaration. Logic declarations have a similar format to theory declarations. Attributes with the following predefined keywords are predefined attributes, with prescribed usage and semantics in logic declarations [7]:

```
:theories :language :extensions :notes :values .
Additionally a logic declaration can contain any number of user-defined attributes.
<logic_attribute> := :theories ( <symbol> + )
    | :language <string>
    | :extensions <string>
    | :values <string>
    | :notes <string>
    | <attribute>
<logic> ::= ( logic <symbol> <logic_attribute> + )
```

SMT-LIB logics refer to one or more theories:

- Functional arrays with extensionality (ArraysEx),
- Bit vectors with arbitrary size (FixedSizeBitVectors),
- Core theory, defining the basic Boolean operators (Core),
- Floating point numbers (FloatingPoint),
- Integer numbers (Ints),
- Real numbers (Reals),
- Real and integer numbers (Reals\_Ints) [6-8].

We propose to add a theory of nominative data to SMT-LIB, serving as a standard format for formulas that include operations on nominative data.

## 2 Composition-Nominative Approach

One of the approaches to software specification is composition programming [1-4]. Composition programming studies the systems at different levels of abstraction – abstract, Boolean and nominative (attribute) levels. Systems of the last level based on the composition-nominative methods [1] are rather expressive for adequate representation of the models of data structures and programs.

Thus, the composition-nominative approach provides a single methodological basis to formalize the concept of program specification, bringing their features and their further specification to programming languages of the lower level. This approach is based on the following principles [1, 4]:

Development principle (from abstract to concrete): program notions should be introduced as a process of their development that starts from abstract understanding, capturing essential program properties, and proceeds to more concrete considerations.

The principle of priority of semantics over syntax: program semantic and syntactic aspects should be first studied separately, then in their integrity in which semantic aspects prevail over syntactic ones.

Compositionality principle: programs can be constructed from simpler programs (functions) with the help of special operations, called compositions, which form a kernel of program semantics structures.

Nominativity principle: nominative (naming) relations are basic ones in constructing data and programs.

Here we have formulated only principles relevant to the topic of the article. A richer system of principles is developed in [1-4].

### 3 Nominative Data

Class  $ND$  of nominative data is constructed by the following recursive definition based on some sets of names of  $V$  and values of  $W$ :  $ND = W \cup (V \xrightarrow{m} ND)$ , where  $V \xrightarrow{m} ND$  is the class of partial multi-valued (non-deterministic) functions.

For nominative data representation we use the form  $d = [v_i \mapsto a_i \mid i \in I]$ , where  $I$  is some set of indices. Nominative membership relation is denoted by  $\in_n$ . Thus,  $v_i \mapsto a_i \in_n d$  means that the value of  $v_i$  in  $d$  is defined and is equal to  $a_i$ ; this can be written in another form as  $d(v_i) \Downarrow = a_i$ . The class  $ND \setminus W$  is called the class of proper nominative data, or hierarchical nominative data; data from the class  $V \xrightarrow{m} ND$  will be called flat nominative data, or nominative sets

Main functions over the nominative data are the following functions: naming  $\Rightarrow v_D$  and denaming of  $v \Rightarrow_D$  with a parameter  $v \in V$ , and binary operations and predicates, such as: union  $\cup_D$ , subtraction  $\setminus_D$ , equality  $(=_{W})_D$  on  $W$ . The function of construction of the empty nominative data  $\overline{[\ ]}_D$ , predicate of membership on  $W$ :  $\in W_D$  are also defined. Operation of renaming  $r_x^y$  for the nominative data  $([a_1 \mapsto b_1, \dots, v \mapsto b_i, \dots])$  yields  $[a_1 \mapsto b_1, \dots, x \mapsto b_i, \dots]$ . The main compositions of functions over nominative data are binary compositions: multiplication  $\circ_D$ , iteration  $*_D$ , merging  $\Theta_D$  and branching ternary composition  $\diamond_D$ . It is shown that the composition of multiplication corresponds to the consecutive application of functions, composition of branching – to the conditional operator if-then-else of programming languages, composition of iteration  $*_D$  – to operator until-do, and composition of merging  $\Theta_D$  connects nominative data resulting from function-arguments.

The special kind of computability – nominative computability – is introduced for consideration and studied in [3]. Nominative functions are the functions over the nominative data obtained by closing of functions

$$\{\Rightarrow 0, \Rightarrow 1, \overline{[\ ]}_D, \setminus_D, \cup_D, (=_{W})_D, as_D, cn_D, \in W_D\}$$

under compositions  $\{\circ_D, \diamond_D, *_D, \Theta_D\}$ .

It is demonstrated [3] that an arbitrary partial recursive function can be represented by nominative computable functions over the set of natural numbers by modelling in the class of nominative data. In addition, it is shown in [3] that each nominative function can be represented by some binary  $\Sigma$ -predicate  $P(x, y)$ , i.e.  $f(x) = y$  if and only if  $P(x, y)$  [2, 3]. For this purpose, the presentation of all functions specified in the definition of nominative computability are built, as well as all the functions obtained by using the compositions.

Axiomatic theory of nominative data [2] is developed in the spirit of the theory of admissible sets (S. Kripke, R. Platek, J. Barwise, Yu.L. Yershov). This theory has a number of advantages with respect to the adequacy of the programming: on the one hand, it is quite powerful to generate computable functions over the different data structures, on the other hand, it is not so restrictive as different versions of constructive logic, but it is not excessively powerful and does not allow, for example, the use of axiom of constructing the set of all subsets (compared with theory of sets by Zermelo-Frankel). Moreover, this theory uses the basic data (elements) corresponding to the methods of constructing data in programming. The unary predicate  $U$  is used, true on the elements of the basic set  $W$ ; the structure  $\langle A, \in_n, =, U \rangle$  is considered. The theory of nominative data is constructed as the axiomatic theory of the first-order logic with equality and ternary nominative membership relation (predicate) of the that written in the infix form  $x \mapsto y \in_n a$  (or  $(x, y) \in_n a$ ).

The class of  $\Delta_0$  - formulas is the smallest class  $Y$ , containing the basic formulas and closed under the following rules:

- 1) if  $\varphi \in Y$ , then also  $\neg\varphi \in Y$ ,
- 2) if  $\varphi, \psi \in Y$ , then  $\varphi \wedge \psi \in Y$  and  $\varphi \vee \psi \in Y$ ,
- 3) if  $\varphi \in Y$ , then  $\forall x \mapsto y \in_n a \varphi, \exists x \mapsto y \in_n a \varphi \in Y$  for all variables  $x, y, a$ .

Class of  $\Sigma$ -formulas is the smallest class  $Z$ , containing  $\Delta_0$ -formulas and closed in relation to the conditions 2) and 3) determining the class of  $\Delta_0$ -formulas and further conditions of existential quantification: if  $\varphi \in Z$ , then  $\exists u \varphi \in Z$ .

## 4 The Domain of Nominative Data

The theory of nominative data is of interest for software modelling and verification, but currently lacks support in the SMT-LIB format. Therefore, we propose the theory of nominative data for the SMT-LIB Standard 2.6 [7, 8].

For convenience, the definition of nominative data in the SMT-LIB Standard is presented via the concepts of nominative pair  $(x \mapsto y)$  and nominative set  $([a_1 \mapsto b_1, \dots, x \mapsto b_i, \dots])$ . Nominative pair of two typed elements are the most basic collection datatype that we propose for an SMT-LIB theory. Semantically, assuming that the type  $t_1$  denotes the non-empty domain (name)  $a$  and the type  $t_2$  denotes the domain (value)  $b$ , the type *NdPair*  $a$  to  $b$  denotes the domain  $a \mapsto b$ . Table 1 contains all proposed operations on nominative pairs in mathematical and in concrete SMT-LIB notation.

This table gives a signature of the proposed SMT-LIB theory of nominative pairs. In the first column of Table 1, we specify a mathematical notation for the functions used with nominative pairs. In the mathematical notation, we use the following notation:  $a_i$  or  $v$  are names in the nominative pairs,  $b_i$  is the value in the nominative pair, and  $d$  is the nominative pair. In the second column of Table 1, we specify a proposed SMT-LIB notation for each operation. In the third column of Table 1, we specify a signature for each operation. In the signature definition, we use the following notation:  $\alpha$  is a set of names in nominative pairs, and  $\beta$  is a set of values in nominative pairs.

**Table 1.** Signature of the SMT-LIB the theory of nominative data for nominative pair

<b>Math. notation</b>	<b>Proposed SMT-LIB notation</b>	<b>Prop. SMT-LIB typing</b>
$a_1 \mapsto b_1 =_v a_2 \mapsto b_2 =$ $= \begin{cases} T, \text{ if } a_1 = a_2 \\ F, \text{ otherwise} \end{cases}$ equality by name =	(ndpair <term> <term>) (pairnameequal <term> <term>)	(NdPair $\alpha$ to $\beta$ , NdPair $\alpha$ to $\beta$ )
$a_1 \mapsto b_1 \equiv a_2 \mapsto b_2 =$ $= \begin{cases} T, \text{ if } b_1 = b_2 \\ F, \text{ otherwise} \end{cases}$ equality by value $\equiv$	(pairvalueequal <term> <term>)	(NdPair $\alpha$ to $\beta$ , NdPair $\alpha$ to $\beta$ )
$a_1 \mapsto b_1 = a_2 \mapsto b_2 =$ $= \begin{cases} T, \text{ if } (a_1 = a_2) \text{ and } (b_1 = b_2) \\ F, \text{ otherwise} \end{cases}$ equality=	(ndpairequal <term> <term>)	(NdPair $\alpha$ to $\beta$ , NdPair $\alpha$ to $\beta$ )
$\Rightarrow v_D(d) = (v, d)$ denaming	(naming <term> <term> <term>)	( $\alpha$ , $\beta$ , NdPair $\alpha$ to $\beta$ )
$r_a^v([v \rightarrow b_1]) = [a \rightarrow b_1]$ Renaming	<pairrenaming <term> <term> <term>)	( $\alpha$ , $\beta$ , NdPair $\alpha$ to $\beta$ , NdPair $\alpha$ to $\beta$ )

Note, that the type of an  $n$ -ary predicate SMT-LIB is in specified by an  $n$ -tuple  $(t_1 \dots t_n)$ , while the type of an  $n$ -ary function with result type  $t_0$  is given by an  $(n + 1)$ -tuple  $(t_1 \dots t_n t_0)$ .

A Declaration for a nominative pair for theory of nominative data for the SMT-LIB Standard is given in Fig. 1.

```
(theory NominativePair

:smt-lib-version 2.6
:written_by "Liudmyla Omelchuk"
:date "15/01/2019"

:sorts ((Int 1) (NdPair 2)))

:funs (
  (par (X Y) (ndpair X Y (NdPair X Y)))
  (par (X Y) (naming X Y (NdPair X Y)))
  (par (X Y) (pairrenaming (NdPair X Y) X (NdPair X Y)))
  (par (X Y) (pairnameequal (NdPair X Y) (NdPair X Y) Bool))
  (par (X Y) (pairvalueequal (NdPair X Y) (NdPair X Y) Bool))
  (par (X Y) (pairequal (NdPair X Y) (NdPair X Y) Bool)))

:definition

"Let Q be a set of sort symbols including NdPair and Bool, and let S
be the set of all (ground) sort terms over Q. For any s in S and any
```

```

function symbol f, let [[s]] and [[f]] respectively denote the inter-
pretation of s and f in some given structure.

For any S like the above, NominativePair(S) is the theory consisting
of all structures satisfying the following restrictions for all s, s'
in S:
- [[(NdPair s s')]] is the pair from [[s]] to [[s']].

- For all name n and data d
  [[naming]](n, d) = [[(NdPair n d)]].

- For all nominative pair p from [[n]] to [[v]] and all name x
  [[paitrenaming]](p, x) = [[(NdPair x v)]].

- For all nominative pairs a from [[n1]] to [[v1]] and nominative
pair b from [[n2]] to [[v2]],
  [[pairnameequal]](a, b) =      true      if n1 = n2
                             false     otherwise.

- For all nominative pairs a from [[n1]] to [[v1]] and nominative
pair b from [[n2]] to [[v2]],
  [[pairvalueequal]](a, b) =  true      if v1 = v2
                             false     otherwise.

- For all nominative pairs a from [[n1]] to [[v1]] and nominative
pair b from [[n2]] to [[v2]],
  [[pairequal]](a, b) =  true      if (v1 = v2) and (n1 = n2)
                        false     otherwise.
"
:note
"
For any given S, NominativePair(S) has several models which differ
not only on how they interpret the base sorts of S other than Int and
Bool, but also on how they interpret the 'apply' function symbol when
the value of a map is queried at a point outside of its domain.
")

```

**Fig. 1.** A declaration for a theory of nominative pair

Nominative set of nominative pairs is the collection datatype that we propose for SMT-LIB theory. Semantically, the nominative set types denote sets  $NdSet(A, B)$  of finite partial functions. The Table 2 contains all proposed operations on nominative sets in mathematical and in concrete SMT-LIB notation. This table gives a signature of the proposed SMT-LIB theory of nominative set.

In the first column of Table 2, we specify a mathematical notation for the functions used with nominative data. In the mathematical notation, we use the following notation:  $a_i$  or  $v$  are names in the nominative pairs,  $b_i$  is the value in the nominative pair, and  $d$  is the nominative set. In the second column of Table 2, we specify a proposed SMT-LIB notation for each operation. In the third column of Table 2, we specify a signature for each operation. In the signature definition, we use the following notation:  $\alpha$  is a set of names in nominative pairs,  $\beta$  is a set of values in nominative pairs, and  $\gamma$  is a set of nominative pairs.

**Table 2.** Signature of the SMT-LIB theory of nominative data for nominative set

<b>Math. notation</b>	<b>Proposed SMT-LIB notation</b>	<b>Proposed SMT-LIB typing</b>
$[a_1 \mapsto b_1, \dots]$	$(\text{NdSet } \langle \text{term} \rangle^*)$	$((\gamma)^* \text{NdSet } \alpha \text{ to } \beta)$
$a \rightarrow b \in {}_n d$	$(\text{ndin } \langle \text{term} \rangle \langle \text{term} \rangle)$	$(\gamma, \text{NdSet } \alpha \text{ to } \beta)$
$\Rightarrow v_D(d) = [v \rightarrow d]$	$(\text{naming } \langle \text{term} \rangle \langle \text{term} \rangle)$	$(\alpha \beta \text{NdSet } \alpha \text{ to } \beta)$
$f \nabla g = g \cup \{(v, w) \mid (v, w) \in {}_n f \ \& \ \neg \exists w' (v, w') \in {}_n g\}$	$(\text{ndoverlay } \langle \text{term} \rangle \langle \text{term} \rangle \langle \text{term} \rangle)$	$(\text{NdSet } \alpha \text{ to } \beta \text{NdSet } \alpha \text{ to } \beta \text{NdSet } \alpha \text{ to } \beta)$
$\cup_D (d_1, \dots, d_n) = [v \mapsto d \mid v \mapsto d \in {}_n d_1 \dots \vee v \mapsto d \in {}_n d_n]$	$(\text{ndunion } \langle \text{term} \rangle^+)$	$(\text{NdSet } \alpha \text{ to } \beta)^+ \text{NdSet } \alpha \text{ to } \beta$
$\setminus D(d_1, d_2) = [v \mapsto d \mid v \mapsto d \in {}_n d_1 \wedge v \mapsto d \notin {}_n d_2]$	$(\text{ndsetminus } \langle \text{term} \rangle \langle \text{term} \rangle)$	$(\text{NdSet } \alpha \text{ to } \beta \text{NdSet } \alpha \text{ to } \beta \text{NdSet } \alpha \text{ to } \beta)$
$\overline{[\ ]}_D(d) = [ ]$	$(\text{emptyNdSet } \langle \text{term} \rangle)$	$(\text{NdSet } \alpha \text{ to } \beta \text{NdSet } \alpha \text{ to } \beta)$
$=_D (d_1, d_2) = \begin{cases} T, & \text{if } d_1, d_2 \in W, d_1 = d_2 \\ F, & \text{if } d_1, d_2 \in W, d_1 \neq d_2 \\ \uparrow, & \text{otherwise} \end{cases}$	$(\text{ndequal } \langle \text{term} \rangle \langle \text{term} \rangle)$	$(\text{NdSet } \alpha \text{ to } \beta \text{NdSet } \alpha \text{ to } \beta)$
$r_x^v([a_1 \mapsto b_1 \dots, v \mapsto b_i, \dots]) = [a_1 \mapsto b_1 \dots, x \mapsto b_i]$	$(\text{ndrenaming } \langle \text{term} \rangle \langle \text{term} \rangle \langle \text{term} \rangle \langle \text{term} \rangle)$	$(\alpha \alpha \text{NdSet } \alpha \text{ to } \beta \text{NdSet } \alpha \text{ to } \beta)$
$\subseteq_D (d_1, d_2)$	$(\text{ndsubset } \langle \text{term} \rangle \langle \text{term} \rangle)$	$(\text{NdSet } \alpha \text{ to } \beta \text{NdSet } \alpha \text{ to } \beta)$

The theory of nominative data defines a parameterized sort and functions to read and write elements of NdSet.

The new sort symbol NdSet takes two sort parameters: the first is the sort of the name, the second is the sort of the value of the nominative data elements.

Two values of the same NdSet sort are equal if the Set elements are equal for every value of the name sort.

A declaration for a nominative set of the theory of nominative data for the SMT-LIB Standard is presented in Fig. 2.

```
(theory NominativeSet
  :smt-lib-version 2.6
```

```
:written-by "Liudmyla Omelchuk"
:date "2019-02-25"
```

```
:sorts ((Int 1) (NDSet 2))
```

```
:funs (((par (X) (emptyNdSet (NdSet X)))
(par X) (naming X X (NdSet X) (NdSet X) :right_assoc)
(par X) (denaming X (NdSet X) (NdSet X) :right_assoc)
(par X) (ndin (NdPair(X Y)) (NdSet Z) Bool))
(par X) (ndsubset (NdSet X) (NdSet X) Bool :chainable))
(par X) (ndunion (NdSet X) (NdSet X) (NdSet X) :right_assoc))
(par X) (ndoverlay (NdSet X) (NdSet X) (NdSet X) :right_assoc))
(par X) (ndsetminus (NdSet X) (NdSet X) (NdSet X) :right_assoc))
(par X) (ndequal (NdSet X) (NdSet X) Bool :chainable))
(par X) (renaming X X (NdSet X) (NdSet X) :right_assoc))
```

```
:definition
```

"Let  $Q$  be a set of sort symbols including Set, Int, and Bool, and let  $S$  be the set of all (ground) sort terms over  $Q$ . For any  $s$  in  $S$  and any function symbol  $f$ , let  $[[s]]$  and  $[[f]]$  respectively denote the Interpretation of  $s$  and  $f$  in some given structure.

For any  $S$  like the above,  $\text{NominativeSet}(S)$  is the theory consisting of all structures satisfying the following restrictions for all  $s$  in  $S$ :

- $[[\text{Set } s]]$  is the set of all finite subsets of  $[[s]]$ .
- $[[f]]$  is as expected if  $f$  is in  $\{\text{subset}, \text{in}\}$ .
- $[[\text{NdSet } s \text{ } s']]]$  is the nominative set of all finite partial maps from  $[[s]]$  to  $[[s']]$ .
- $[[\text{emptyNdSet}]]$  is the function from  $[[s]]$  to  $[[s']]$  undefined everywhere.
- For all nominative sets  $m$  and name  $x$ ,  
 $[[\text{naming}]](x, m) = [[\text{NdPair } x \text{ } m]]$  is the nominative set of all finite partial maps from  $[[x]]$  to  $[[m]]$ .
- For all nominative set  $m$  and name  $x$ ,  
 $[[\text{denaming}]](x, m) = \begin{matrix} b & \text{if } [[\text{NdPair } x \text{ } b]] \text{ in } m \\ \text{undefined} & \text{otherwise.} \end{matrix}$
- For all nominative set  $m$ , name  $n$  and nominative set  $v$ ,  
 $[[\text{ndin}]]([[ \text{NdPair } n \text{ } v ]], m) = \begin{matrix} \text{true} & \text{if } [[\text{NdPair } x \text{ } b]] \text{ in } m \\ \text{false} & \text{otherwise.} \end{matrix}$
- For all  $n > 0$ , nominative set  $a$  and nominative set  $b$  of  $[[b_1]], \dots, [[b_n]]$ ,  
 $[[\text{ndsubset}]](b, a) = \begin{matrix} \text{true} & \text{if } b_i \text{ ndin } a \text{ for all } i = 1, \dots, n \\ \text{false} & \text{otherwise.} \end{matrix}$
- For all  $n, m > 0$ , nominative set  $a$  of  $[[a_1]], \dots, [[a_n]]$  and nominative set  $b$  of  $[[b_1]], \dots, [[b_m]]$ ,  
 $[[\text{ndunion}]](b, a) = [[a_1, \dots, a_n, b_1, \dots, b_m]]$ .

```

- For all n, m > 0, nominative set a of [(NdPair a1 b1)],...[(
NdPair an bn))] and nominative set b,
  [[ndoverlay]](a, b) = [[ndunion]](b,
  { x ndin [(NdPair a1 b1)],...[( NdPair an bn))] |
  there in not any d (NdPair ai d) ndin b }).

- For all k > 0, nominative set a of [[a1]], ..., [[an]] and nomi-
native set b of [[b1]], ..., [[bm]],
  [[ndsetminus]](a, b) = {x ndin [[s1],...[[sk]] |
  for all i <=k si idin a and not (si indin b)}.

- For all nominative set a of [(NdPair a1 b1)],...[( NdPair an
bn))] and name x,

  [[renaming]](x, y, a) = {x ndin [(NdPair a1 b1)],...
  [( NdPair am bm))] | for all i<=m
  ((NdPair ai bi) dnin [(NdPair a1 b1)],...
  [( NdPair an bn)]]) and (not ai = x) } ndunion
  { [[(NdPair y bj)] | [(NdPair x bj)] ndin
  [(NdPair a1 b1)],...[( NdPair an bn)]]}.

- For all k > 0, nominative set a [[a1]], ..., [[an]] and nomina-
tive set b,
  [[ndsubset]](a, b) =      true    if for all i <=n ai idin b
                          false   otherwise.

- For all nominative sets a, b
  [[ndequal]](a, b) = (a ndsubset b) and (b ndsubset a).

- [[n]] is as expected if n is a numeral.

- [[(NdSet s)]] is the set of all finite subsets of [[s]].

- [[f]] is as expected if f is in
  { emptyNdSet, naming, denaming, ndin, ndsubsetm ndunion,
  ndoverlay, ndsetminus, ndsubset, ndequal, renaming}.
")

```

**Fig. 2.** A declaration for a theory of nominative set

Using proposed by the authors the SMT-LIB theory of nominative data, we can adequately determine the structure of programming data and operations on them.

For example, the following statement in terms of the theory of nominative data:

$$\forall a \exists s (a \in_n s)$$

can be specified in the form of the following SMT- LIB notation:

```
(forall ((a (NdPair Int))) (exists ((s (NdSet Int))) (ndin a s)))
```

Fig. 3-4 give an example of the use of nominative data structures in theorem prover Z3, which is one of the SMT solvers.



```

1 (set-option :smt.auto-config false) ; disable automatic self configuration
2 (set-option :smt.mbqi true)
3 (declare-datatypes (T) ((NdPair (mk-ndpair (first T) (second NdSet)))
4 (NdSet nil (cons (hd NdPair) (tl NdSet))))))
5 (declare-const emptyNdSet (NdSet Int))
6 (assert (= emptyNdSet nil))
7 (define-fun-rec ndin ((x (NdPair Int)) (s (NdSet Int))) Bool
8 (if (= s emptyNdSet) false
9 (if (= x (hd s)) true
10 (ndin x (tl s))))))
11
12 (declare-const s1 (NdSet Int))
13 (declare-const p1 (NdPair Int))
14 (declare-const x Int)
15 (assert (forall ((p (NdPair Int))) (exists ((s (NdSet Int))) (ndin p s))))
16
17 (check-sat)
18 (get-model)

```

Fig. 3. An example of the use of nominative data structures in Z3

```

sat
(model
  (define-fun emptyNdSet () (NdSet Int)
    nil)
  (define-fun s!0 ((x!0 (NdPair Int))) (NdSet Int)
    (cons (mk-ndpair 0 nil) nil))
  (define-fun ndin ((x!0 (NdPair Int)) (x!1 (NdSet Int))) Bool
    (let ((a!1 (not (or (= x!1 (hd x!0)) (ndin x!1 (tl x!0))))))
      (not (or (= x!0 nil) a!1))))
)

```

samples      about Z3 - Efficient Theorem Prover

Fig. 4. An example of a satisfiable of nominative data structures in Z3

The link to <https://sites.google.com/knu.ua/nominative-data> contains information that relates the description of Extended SMT-Lib Standard with Theory of Nominative Data [10].

## 5 Conclusion

In the article, we have proposed the extension of the SMT-LIB Standard with theory of nominative data. This theory is of interest for software modelling and verification. At the same time, the declaration for the SMT-LIB Standard for the theory of nominative data has not yet been proposed.

To construct the extension of the SMT-LIB Standard for the constructed theory of nominative data, we have described the main principles of the composition-nominative approach and the definition of the class of nominative data. Such data form a basis for adequate definition of data structures, functions, and compositions of programming languages [2-4].

We are developing SMT solvers with nominative data support. In the forthcoming articles we will demonstrate applications of the proposed theory.

## References

1. Nikitchenko, N.: A Composition Nominative Approach to Program Semantics. Techn. Report IT-TR. Technical University of Denmark, Lyngby (1998).
2. Omelchuk, L.: Aksiomatychni systemy specyfikacij program nad nominatyvnymi danymy [Axiomatic Systems of Specifications of Programs over Nominative Data]. Candidate's thesis. Kyiv [in Ukrainian] (2007).
3. Nikitchenko, N., Omelchuk, L., Shkilniak S.: Formalisms for Specification of Programs over Nominative Data. Electronic computers and informatics (ECI 2006). Košice, Herľany, Slovakia, 134-139 (2006).
4. Kryvolap, A., Nikitchenko, M., Schreiner, W.: "Extending Floyd-Hoare logic for partial pre- and postconditions", CCIS 412, Springer, Heidelberg, pp. 355-378. (2013).
5. Leino, K.R.M.: Dafny: An Automatic Program Verifier for Functional Correctness. In LPAR-16, 6355:348-370. LNCS. Springer. (2010).
6. Moura, L., Bjørner, N.: Z3: An efficient smt solver. In In Conference on Tools and Algorithms for the Construction and Analysis of Systems (TACAS). (2008).
7. Barrett, C., Fontaine, P., Tinelli, C.: The SMT-LIB Standard: Version 2.6. Publishing house of Department of Computer Science, The University of Iowa. (2017). Homepage, <http://www.SMT-LIB.org> , last accessed 2019/03/11.
8. Nieuwenhuis, R., Oliveras, A., Tinelli, C.: Solving SAT and SAT Modulo Theories: From an Abstract Davis-Putnam-Logemann-Loveland Procedure to DPLL(T). Journal of the ACM. T. 53, vol. 6, pp. 937-977. (2006).
9. Sutcliffe, G., Suttner, C.: The TPTP problem library—CNF release v1.2.1. J. Autom. Reasoning, 21(2). pp. 177-203. (1998).
10. Theory of Nominative Data, <https://sites.google.com/knu.ua/nominative-data>, last accessed 2019/04/21.

# Data Compression and Representation as Multicolor Barcodes

Ivan Dychka<sup>[0000-0002-3446-3076]</sup> and Olga Sulema<sup>[0000-0001-6450-0993]</sup>

National Technical University of Ukraine “Igor Sikorsky Kyiv Polytechnic Institute”,  
37 Prospekt Peremohy, 03056 Kyiv, Ukraine  
dychka@pzks.fpm.kpi.ua, olga.sulema@pzks.fpm.kpi.ua

**Abstract.** A method for data compression and representation of textual information in the form of a barcode is proposed in the paper. The main idea of the proposed method is preliminary data compressing along with the use of three colors. Increasing the number of colors used in a barcode symbol allows to encode data with higher density in comparison with two-color barcodes. Thus, the advantage of the proposed method is that it enables either representation of the same amount of input data on a smaller area or a larger amount of data in a barcode symbol of the same size. The matter of a color contrast is also discussed in the paper. Since an information carrier (e.g. goods package) can have an arbitrary background color depending on a use case, a contrast ratio value should be considered while choosing a specific set of colors for barcode elements in each particular use case to make the barcode reading procedure more accurate.

**Keywords:** Barcoding, Multicolor Barcode, Data Compression, Color Contrast.

## 1 Introduction

Although barcodes as a technology appeared in the early 1950s, when the first patent for the barcode was received, their popularity has not been reduced even in the contemporary era of smartphones and mass digitalization. On the contrary, barcoding technology use is widening in practical applications because of its evident advantages: data entering accuracy, processing time reduction, scanning simplicity, etc.

Matrix, or two-dimensional, barcodes deserve particular attention. Among multiple benefits any barcode offers, 2D barcodes allow to encode more information than it would be possible using a classical one-dimensional barcode, due to storing data both horizontally and vertically. As a result, there are countless possible applications for matrix barcodes starting from logistics and advertising and finishing with hospitals and financial institutions. New use cases are constantly appearing as the use of portable digital devices, smartphones in particular, is headily expanding.

Along with the emergence of new applications, new problems concerned with barcodes arise. Specifically, one of the subjects of particular interest is increasing amounts of encoded data with preservation of a barcode symbol size. The possible way of resolving this problem is to augment number of colors, which are used in a

barcode. Normally, black and white are the colors of any barcode. Adding the third color allows to increase data storing capacity of a barcode symbol in comparison with a black-and-white barcode.

The most well-known among multicolor barcodes is Microsoft's High Capacity Color Barcode (HCCB) [1]. The main benefit of the HCCB code is that greater compression can be achieved due to the use of 4 or 8 colors, instead of standard black-and-white palette. Moreover, data can occupy smaller space at the barcode symbol because of the triangle shape of HCCB symbols. However, a HCCB code requires Microsoft libraries and software to be installed in order to create or use it, and there are no open source libraries. It limits new applications development to a certain extent.

In [2] the authors propose the High Capacity Colored Two Dimensional (HCC2D) code approach aimed at increasing data amount that can be stored along with preserving the strong reliability and robustness properties of a standard QR code. The authors provided their experimental results, which showed that HCC2D has higher data density than QR code does, although its computational overhead is lower. The main advantage of HCC2D is that this new approach solves most of the problems appearing in detection and alignment of a standard 2D code.

The authors of the paper [3] present a new approach to color barcode decoding which does not require a reference color palette. They also propose algorithms to select subsets of barcode elements which can be decoded with low error probability.

In the patent [4] the authors propose the way of storing data decoded from a barcode as character-based data in an auxiliary field (e.g. a comment field) of an image file.

An approach to the localization and segmentation of a 2D color barcode as well as its evaluation on a diverse collection of images of Microsoft's HCCB is presented and discussed in [5].

Multicolor barcodes have considerable potential that should be developed. There are numerous problems, which can be solved in various ways, and one of such problems is, in particular, compressing data before encoding them, what would result in increasing an overall barcode capacity. In this paper we propose a new method of the tricolor barcoding, which combines the multicolor concept and additional data compression.

## 2 The Tricolor Barcoding Method

### 2.1 Method Description

A *matrix barcode symbol*, which is the subject of the proposed research, consists of a set of tricolor barcode patterns. In its turn, a *barcode pattern* is considered as a graphical representation of  $s$  elements, which are matrix cells of one of three colors.

Maximum capacity of a barcode symbol is  $V_{max} = 3^s$  barcode patterns, as we consider 3 colors and  $s$  is a number of cells in the barcode pattern. Table 1 presents the relationship between barcode symbol maximal capacity and barcode pattern digital capacity.

**Table 1.** Barcode symbol maximal capacity dependence on barcode pattern digital capacity

$s$	$3^s$	$V_{max}$
4	$3^4$	81
5	$3^5$	243
6	$3^6$	729
7	$3^7$	2187
8	$3^8$	6561
9	$3^9$	19683
10	$3^{10}$	59049

As it is shown in Table 1, a tricolor barcode can consist of 59049 matrix cells, which means that 7 Kbyte can be stored in a barcode symbol of size  $243 \times 243$  cells. If comparing with a standard QR code, there are 40 preset sizes referred to as versions [6]. Version 1 has  $21 \times 21$  cells size. The highest version is Version 40, which has  $177 \times 177$  cells and, therefore, consists of 31329 cells that can encode 3 Kbyte of data. Thus, the approach we propose in this paper allows to store much larger amount of information in one barcode, even though of bigger size.

Let us define a *symbolism of the barcode*, which is an alphabet  $\Omega$  of cardinality  $P_\Omega = 3^s$ . The alphabet  $\Omega$  consists of all possible  $s$ -digits tricolor barcode patterns. Barcode patterns can be divided into two groups: informational patterns  $\Omega_{inf}$  and auxiliary patterns  $\Omega_{aux}$ . Capacity of informational patterns is  $P_{\Omega_{inf}}$  and capacity of auxiliary patterns is  $P_{\Omega_{aux}}$ . Since  $\Omega = \Omega_{inf} \cup \Omega_{aux}$ , then  $P_{\Omega_{inf}} + P_{\Omega_{aux}} = P_\Omega = 3^s$ . Informational barcode patterns are used to encode input information that shall be represented on a carrier. Auxiliary patterns are aimed to store additional information, such as indicators of switching between encoding modes, START and STOP signs, scanner settings, etc.

An initial input textual data can be considered as a sequence of alphanumeric symbols  $\mathbb{T} = t_1 t_2 \dots t_h$ , where  $t_i \in \text{ASCII}(256)$  and  $h$  is a length of the text. Each symbol can belong to one of the character sets: a set of letters  $L$ , a set of digits  $D$  or a set of special symbols  $C$ .

To be encoded, the input sequence  $\mathbb{T}$  is divided into adjacent subsequences  $w_1 w_2 \dots w_k$ , where  $w_i = t_1 t_2 \dots t_n$  contains elements  $t_i$  from either  $L$ ,  $D$  or  $C$  character sets. In  $\mathbb{T}$ , the subsequences can follow each other in any order.

In general, alphanumeric symbols  $t_i$  belong to extended ASCII. However, practically there is no need to consider 256 ASCII characters, as each use case uses a certain set of characters. Thus, we consider *an alphabet*  $A$ , which is a subset of extended ASCII with cardinality  $P_A$  consisted of a restricted number of characters that are used in the certain domain. The alphabet  $A$  corresponds to a numeric set  $\{0, 1, \dots, P_A - 1\}$  that represents numbers of the symbols as they are ordered in the alphabet  $A$ .

Let us now overview the proposed Tricolor Barcoding Method. Generally, each subsequence  $w_i = t_1 t_2 \dots t_n$  of the symbols of the alphabet  $A$  must be transformed into a barcode pattern. The consecutive set of barcode pattern form then a tricolor matrix barcode symbol that can be located on a physical carrier.

Thus, in the barcode form, the subsequence  $t_1 t_2 \dots t_n$  of  $n$  alphanumeric characters corresponds to a subsequence  $u_z$  of  $m$  barcode patterns:  $u_z = \omega_1 \omega_2 \dots \omega_m$ , where  $\omega \in \Omega_{inf}$ .

At the first stage of the method, the transformation  $w_i \rightarrow u_z$ , i.e.  $(t_1 t_2 \dots t_n) \rightarrow (\omega_1 \omega_2 \dots \omega_m)$  has to be fulfilled. Practically, the transformation of  $n$  adjacent symbols of the alphabet  $A$  into  $m$  barcode patterns of the alphabet  $\Omega_{inf}$  (i.e. the barcode symbolism) means a transformation of  $n$ -digits number in a notation  $P_A$  into  $m$ -digits number in a notation  $P_{\Omega_{inf}}$ :

$$n(P_A) \rightarrow m(P_{\Omega_{inf}}) \quad (1)$$

As the main purpose of this method is to encode input information with a maximal compression so that more textual data can be represented in the same barcode symbol, the following conditions have to be true when fulfilling the transformation (1):

$$\begin{cases} n \lfloor \log_3 P_A \rfloor > ms \\ P_A^n \leq P_{\Omega_{inf}}^m \end{cases} \quad (2)$$

where  $n \lfloor \log_3 P_A \rfloor$  is a length of the ternary sequence, which corresponds to an alphanumeric sequence  $w_i = t_1 t_2 \dots t_n$ , and  $ms$  is a number of tricolor cells on a carrier that represent the subsequence  $w_i$ .

The conditions (2) are necessary to ensure compact data representation on a carrier and to increase data density in barcode patterns with the unchanging carrier size.

In order to assess input data compression, we calculate a ratio of a length of the ternary sequence that corresponds with alphanumeric sequence  $w_i$  to a number of cells on a carrier that represents subsequence  $w_i$  in barcoded form:

$$U_{P_{\Omega_{inf}}}^{(s)}(P_A) = \frac{n \lfloor \log_3 P_A \rfloor}{ms} \quad (3)$$

A number obtained in (3) is called a *compression coefficient* and is the main indicator of the tricolor barcoding method efficiency.

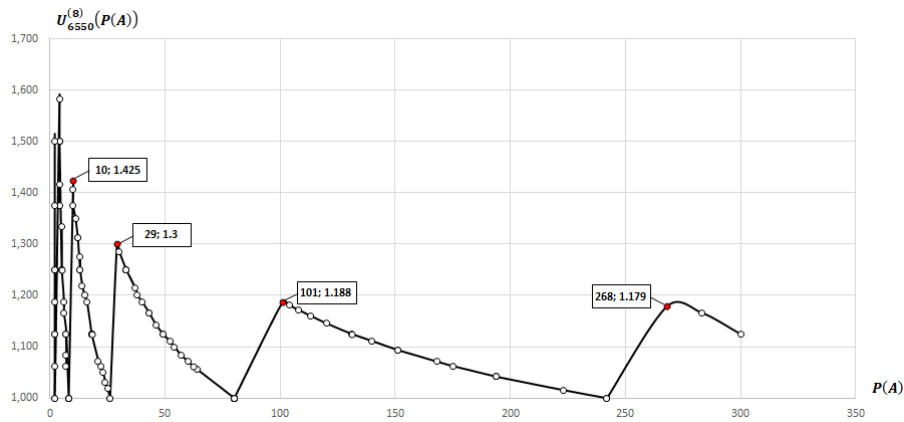
## 2.2 Results Analysis

The method proposed in the section above can provide different results depending on the  $s$  parameter and, consequently, a maximum barcode symbol capacity. In Table 1 the dependency between a number of elements in one barcode pattern and the overall barcode capacity is shown.

The  $s$  parameter is essential for a resulting barcode and compression of data stored in this barcode, as it follows from (2) and (3). The inequality system (2) has to be solved in order to proceed the Tricolor Barcoding Method. Obtained solutions must be analyzed with relation to barcode practical implementation. We search for such alphabet sets that would meet a field of problem, for which a barcode is creating.

Figure 1 shows the dependence of compression coefficient (3) on the alphabet cardinality  $P_A$  for  $s = 8$ . It is easy to see that there are several local extremums among all the solutions of the inequality system (2).

The important remark is that we consider only those values, which are greater than 10. The reason for such restriction is attributable to the fact that an alphabet with cardinality  $P_A = 10$  is the smallest possible alphabet for numerals from 0 to 9. There is no sense to consider smaller alphabets with cardinality  $P_A < 10$ , for example, for parting certain punctuation symbols as a separate alphabet, since they would hardly form a long sequence that could have an impact upon the overall data compression.



**Fig. 1.** The compression coefficient  $U_{6550}^{(8)}(P_A)$  dependence on the alphabet cardinality  $P_A$

The extremums shown at Figure 1 can be considered as possible alphabet cardinalities that shall be used for encoding initial data into a barcode symbol. However, when choosing the alphabets, we must also take into account the transformation (4) as well as a required size of an alphabet. If a determined extremum does not match applied requirements, the nearest proper solution must be considered.

For instance, one of the extremums for  $s = 6$  is equal to 31 with  $U_{718}^{(6)}(31) = 1,267$ . It has quite good compression coefficient, but an alphabet of cardinality  $P_A = 31$  is not enough to cover both Latin letters and numerals from 0 to 9. Therefore, we search for the nearest solution that would meet the size of such alphanumeric alphabet. Such a solution is  $P_A = 38$ . Its compression coefficient is  $U_{718}^{(6)}(38) = 1,200$ , which is 6% less than the extremum has, however it perfectly matches the alphanumeric alphabet consisted of 26 Latin letter and 10 numerals. Moreover, its transformation (4) is "9"  $\rightarrow$  "5", and it is much better than the transformation for the extremum  $P_A = 31$ , which is "19"  $\rightarrow$  "10". Therefore, even though  $P_A = 38$  provides us with smaller compression, it benefits comparing to the extremum.

Thus, a set of requirements has to be taken into consideration, such as: an alphabet cardinality, a compression coefficient value, and complexity of  $n \rightarrow m$  transformation. Practically, these are criteria for the most efficient in particular field alpha-

bets, which poses a multicriteria optimization problem that can be solved with appropriate optimization methods.

The alphabets chosen from among the solutions of (3) form a set of barcoding modes that shall be used when encoding an input alphanumeric sequence. We consider a *barcoding mode* as an alphabet of cardinality  $P_k$ , where  $k$  is one of determined above alphabets comprising all adjacent symbols from subsequence  $w_i \in \mathbb{T}$ . Switching between modes occurs in accordance with a set of rules, which are developed for each field of practical use depending on possible input data and the  $n \rightarrow m$  transformation type. Basically, these rules show what symbols and how many of them must be considered as a  $w_i$  subsequence. To mark a mode switch, auxiliary symbols  $S$ , so-called *mode switchers*, are used.

For example, regarding  $s = 5$ , we can use the following 4 barcoding modes: the ASCII mode with an alphabet  $A$  of cardinality  $P_A = 134$ , the decimal numbers mode with an alphabet  $D$  of cardinality  $P_D = 10$ , the hexadecimal numbers mode with an alphabet  $H$  of cardinality  $P_H = 28$ , and the textual mode with an alphabet  $L$  of cardinality  $P_L = 93$ .

### 3 Color Contrast Ratio in Barcoding

The Tricolor Barcoding Method described in the subsection above is aimed at increasing data density, which is especially important when representing large amount of information. In the general case, these three colors are black, gray, and white (BGW) that makes the method being an extension of a classical matrix black-and-white barcoding approach.

The use of black, gray, and white colors is conditioned by the simplicity of producing such barcode symbols. All it requires is an ordinary black-and-white printer, which also makes a barcode production process cheap and affordable. However, in specific cases the BGW barcodes can be rather hard to be scanned because of inappropriate background colors of a barcode carrier.

The BGW palette is quite a good choice for monochromatic carriers, contrasting to a barcode symbol. In such case, a BGW barcode can easily be read by scanners. The situation is worsening when a carrier background (e.g. packing of goods) either is insufficiently contrasting to BGW palette or consists of several colors or a multicolor pattern. Depending on specific colors and type of environment illumination, scanning might become inaccurate. To overcome the scanning problem, a concept of both contrast range and color models can be used.

In color theory, contrast is the difference in luminance between two adjacent colors or overlaid colors (foreground and background). Luminance is the intensity of light emitted from a surface per unit area in a given direction [7].

In order to raise successfulness of barcode scanning procedure, it is important that colors using in tricolor barcode would be contrast to a background of a carrier object. Thus, background colors must be analyzed in the view of contrast degree before producing a barcode symbol, so that barcode cells would be painted over colors with high contrast ratio.



A color contrast ratio is the ratio of the luminance of the brightest color (which is white in the extreme case) to the luminance of the darkest color (which is black in the extreme case) [8]:

$$r_c = (L_1 + 0.05)/(L_2 + 0.05) \quad (4)$$

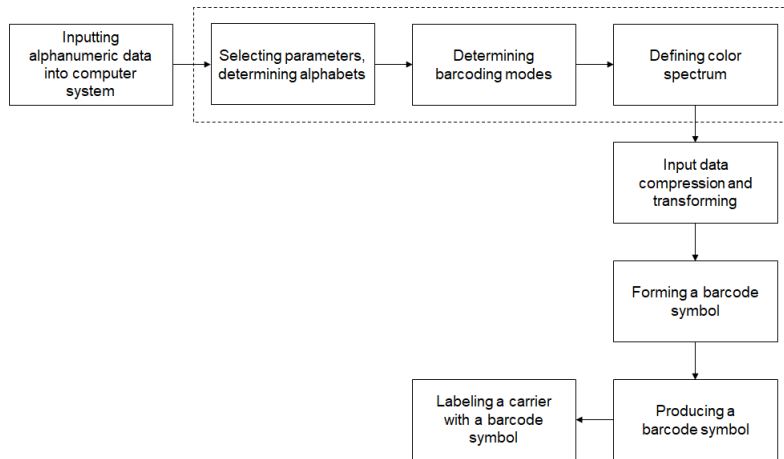
where  $L_1$  is the relative luminance of the lightest of the colors and  $L_2$  is the relative luminance of the darkest of the colors.

Let us consider an example for monochromatic background with the color code #69afdb. If we choose barcode colors  $C_1$  and  $C_2$  with the codes #22047d and #d2ff7f respectively, the contrast ratio for these two colors is 13.28. Then let us take the third color  $C_3$  with the code #e04ceb. The contrast between  $C_1$  and  $C_3$  is 4.63 and the contrast between  $C_2$  and  $C_3$  is 2.86. Thus, the average contrast between barcode colors is 6.9. The average contrast between the background and the barcode is 4.9, which is sufficient for error-free scanning.

#### 4 Technology of Tricolor Barcoding

The proposed Tricolor Barcoding Method allows us to suggest a technology of tricolor or barcoding aimed at encoding input textual data into a tricolor barcode of higher data density and, respectfully, greater information capacity.

The barcoding process can be divided into several phases presented at Figure 2.



**Fig. 2.** The functional model of tricolor barcoding technology

The first phase is inputting textual, mainly alphanumeric, data into computer system. A scanner or a smartphone camera can be used for this purpose.

The second phase is setting the barcoding software up in accordance with the relevant data domain. This process consists of 3 steps: (1) selecting appropriate parame-

ters and defining alphabets, (2) determining barcoding modes, and (3) defining a color spectrum based on the carrier characteristics.

At the third phase initial data are being compressed and transformed into corresponding barcode patterns that form an overall barcode symbol at the next stage.

The process of production of the barcode symbol is considered as the fifth phase of the barcoding technology. At the last stage the ready-made barcode symbol is being located on the carrier as a label. Size and location of the label depend on a use case.

## 5 Conclusion

The barcoding method proposed in this paper allows to encode textual information with increasing data density when representing encoded information as a barcode. The approach combines tricolor barcoding with the auxiliary procedure of data compression. The use of the third color alongside with additional data compression allows to represent more information on the same area of a barcode symbol.

Although the most efficient version of the proposed tricolor barcode is BGW Code, as it uses the black-gray-white palette, which makes a barcode production process to be quite easy and cheap, sometimes these colors are not suitable for accurate scanning from a colored carrier. In this case selection of appropriate colors can increase a contrast ratio for such a carrier and, thus, ensures error-free reading of the barcode.

The tricolor barcoding approach has its potential for further research and development. As barcode labeling is used in multiple use cases, an additional study can be fulfilled in order to determine proper alphabets and, consequently, barcoding modes to make the proposed approach widely used.

## References

1. High capacity color barcodes, <http://research.microsoft.com/en-us/projects/hccb>, last accessed 2019/03/24.
2. Grillo A., Lentini A., Querini M., Italiano G.: High Capacity Colored Two Dimensional Codes. In: International Multiconference on Computer Science and Information Technology, pp. 709–716 (2010).
3. Bagherinia H., Manduchi R.: A theory of color barcodes. IEEE International Conference on Computer Vision, ICCV Workshops (2011).
4. Barrus J, Wolff G. J.: Embedding barcode data in an auxiliary field of an image file. U.S. Patent 7 150 399 (2006).
5. Parikh D., Jancke D.: Localization and Segmentation of A 2D High Capacity Color Barcode. IEEE Workshop on Applications of Computer Vision (2008).
6. QR Codes - How Much Data Can A QR Code Store?, <http://qrcode.meetheed.com/question7.php?s=s>, last accessed 2019/05/06.
7. The Science of Color Contrast—An Expert Designer’s Guide, <https://medium.muz.li/the-science-of-color-contrast-an-expert-designers-guide-33e84c41d156>, last accessed 2019/03/24.
8. Web Content Accessibility Guidelines (WCAG) 2.0, <https://www.w3.org/TR/2008/REC-WCAG20-20081211>, last accessed 2019/03/24.

# On the Kleene Algebra of Partial Predicates with Predicate Complement

Ievgen Ivanov, Mykola Nikitchenko<sup>[0000–0002–4078–1062]</sup>

Taras Shevchenko National University of Kyiv, Ukraine  
ivanov.eugen@gmail.com, nikitchenko@unicyb.kiev.ua

**Abstract.** In the paper we investigate the question of expressibility of partial predicates in the Kleene algebra extended with the composition of predicate complement and give a necessary and sufficient condition of this expressibility in terms of the existence of an optimal solution of an optimization problem. The obtained results may be useful for development of (semi-)automatic deduction tools for an extension of the Floyd-Hoare logic for the case of partial pre- and postconditions.

**Keywords:** Formal methods, software verification, partial predicate, Floyd-Hoare logic.

## 1 Introduction

Floyd-Hoare logic [1, 2] is a logic which is useful for proving partial correctness of sequential programs. It is based on properties of triples (assertions) of the form  $\{p\}f\{q\}$ , where  $f$  is a program and  $p, q$  are predicates which specify pre- and post-conditions. An assertion of this kind means that if the program's input  $d$  satisfies the pre-condition  $p$ , and the program terminates on  $d$ , the program's output satisfies the post-condition  $q$ . In the classical Floyd-Hoare logic the program is allowed to be non-terminating (or have an undefined result of execution), but the pre- and postconditions are assumed to be always defined (have a well defined truth value). In the presence of pre- and postconditions defined by partial predicates (which can be undefined on some data) the inference rules (in particular, the sequence rule) of the classical Floyd-Hoare logic become unsound [13, 14], when a triple  $\{p\}f\{q\}$  is understood in the following way: if a precondition  $p$  is defined and true on the program's input, and the program  $f$  terminates with a result  $y$ , and the postcondition  $q$  is defined on  $y$ , then  $q$  is true on  $y$ .

In the previous works [15, 3, 4, 10, 12, 11, 8] we investigated an inference system for an extension of Floyd-Hoare logic which remains sound in the case of partial pre- and postconditions, assuming the above mentioned interpretation of Floyd-Hoare triples. The formulations of the rules of this inference system, however, require introduction of a new composition into the logical language used to express pre- and postconditions. Whereas the formulation of the rules of the classical Floyd-Hoare logic depends on the usual boolean compositions ( $\neg$ ,  $\wedge$ ) of pre- and postcondition predicates (which are assumed to be total), the mentioned extension depends on the compositions of negation ( $\neg$ ) and conjunction

( $\wedge$ ) of partial predicates defined in accordance with the tables of Kleene's strong 3-valued logic, and on one additional unary composition of partial predicates which we call the composition of predicate complement and denote as  $\sim$ . This composition extends the signature of the Kleene algebra of partial predicates [9]. In this paper we investigate the question of expressibility of partial predicates in the Kleene algebra extended with the composition of predicate complement and give a necessary and sufficient condition of this expressibility in terms of the existence of an optimal solution of a special constrained optimization problem. The obtained results may be useful for development of (semi-)automatic deduction tools for the mentioned extension of the Floyd-Hoare logic for the case of partial pre- and postconditions.

## 2 Notation

We will use the following notation. The notation  $f : A \rightarrow B$  means that  $f$  is a partial function on a set  $A$  with values in a set  $B$ , and  $f : A \rightarrow B$  means that  $f$  is a total function from  $A$  to  $B$ . For a function  $f : A \rightarrow B$ :

- $f(x) \downarrow$  means that  $f$  is defined on  $x$ ;
- $f(x) \downarrow = y$  means that  $f$  is defined on  $x$  and  $f(x) = y$ ;
- $f(x) \uparrow$  means that  $f$  is undefined on  $x$ ;
- $dom(f) = \{x \in A \mid f(x) \downarrow\}$  is the domain of a function.

We will denote as  $f_1(x_1) \cong f_2(x_2)$  the *strong equality*, i.e.  $f_1(x_1) \downarrow$  if and only if  $f_2(x_2) \downarrow$ , and if  $f_1(x_1) \downarrow$ , then  $f_1(x_1) = f_2(x_2)$ .

The symbols  $T, F$  will denote the "true" and "false" values of predicates.

We will denote  $Bool = \{T, F\}$ . The symbol  $\perp$  will denote a nowhere defined partial predicate.

Let  $D \neq \emptyset$  be a set, and  $P_0, P_1, \dots, P_n$  be partial predicates on  $D$ .

Let  $APr_{P_1, \dots, P_n}(D) = (D \rightarrow \{T, F\}; \vee, \wedge, \neg, \sim, P_1, P_2, \dots, P_n)$  be an algebra of partial predicates with constants  $P_1, \dots, P_n$ , where

1.  $\vee, \wedge, \neg$  are the operations of disjunction, conjunction and negation on partial predicates defined in accordance with Kleene's strong three-valued logic as follows:

$$(P \vee Q)(d) = \begin{cases} T, & \text{if } P(d) \downarrow = T \text{ or } Q(d) \downarrow = T; \\ F, & \text{if } P(d) \downarrow = F \text{ and } Q(d) \downarrow = F; \\ \text{undefined} & \text{in other cases.} \end{cases}$$

$$(P \wedge Q)(d) = \begin{cases} T, & \text{if } P(d) \downarrow = T \text{ and } Q(d) \downarrow = T; \\ F, & \text{if } P(d) \downarrow = F \text{ or } Q(d) \downarrow = F; \\ \text{undefined} & \text{in other cases.} \end{cases}$$

$$(\neg P)(d) = \begin{cases} T, & \text{if } P(d) \downarrow = F; \\ F, & \text{if } P(d) \downarrow = T; \\ \text{undefined} & \text{in other case.} \end{cases}$$

2.  $\sim$  is the unary operation of predicate complement:

$$(\sim P)(d) = \begin{cases} T, & \text{if } P(d) \uparrow; \\ \text{undefined}, & \text{if } P(d) \downarrow. \end{cases}$$

We will call  $APr_{P_1, \dots, P_n}(D)$  the Kleene algebra of partial predicates on  $D$  with predicate complement and constants  $P_1, \dots, P_n$ .

### 3 Main Result

Let  $F^{(n)}$  be the set of all  $n$ -ary functions (operations)  $f : \{-1, 0, 1\}^n \rightarrow \{-1, 0, 1\}$ . The elements of  $F^{(n)}$  will represent functions of 3-valued logic  $P_3$  (where 1 corresponds to the “true” value and  $-1$  corresponds to the “false” value, and 0 is an intermediate truth value).

Let  $F = \bigcup_{n \geq 0} F^{(n)}$ .

We will denote as  $\bar{x} = (x_1, x_2, \dots, x_n)$  a tuple of values  $x_i \in \{-1, 0, 1\}$ .

Let us consider  $\{-1, 0, 1\}^n$  as a metric space with Chebyshev distance:

$$\rho_n((x_1, \dots, x_n), (y_1, \dots, y_n)) = \max_{i=1}^n |x_i - y_i|.$$

We will say that a function  $f \in F^{(n)}$  is *short*, if it is a short map, i.e. if for all  $\bar{x}, \bar{y}$  we have

$$|f(\bar{x}) - f(\bar{y})| \leq \rho_n(\bar{x}, \bar{y}).$$

For any predicate  $P : D \rightarrow \{T, F\}$  denote by  $\Phi(P)$  a function  $D \rightarrow \{-1, 0, 1\}$  such that for all  $d \in D$ :

$$\Phi(P)(d) = \begin{cases} 1, & \text{if } P(d) \downarrow = T, \\ 0, & \text{if } P(d) \uparrow, \\ -1, & \text{if } P(d) \downarrow = F. \end{cases}$$

Let  $D \neq \emptyset$  be a set,  $P_1, P_2, \dots, P_n : D \rightarrow \{T, F\}$  be partial predicates, and

$$APr_{P_1, \dots, P_n}(D) = (D \rightarrow \{T, F\}; \vee, \wedge, \neg, \sim, P_1, P_2, \dots, P_n).$$

Let  $p_i = \Phi(P_i)$  for  $i = 0, 1, 2, \dots, n$ .

Denote  $\|f\| = \sum_{\bar{x} \in \{-1, 0, 1\}^n} |f(\bar{x})|$  for  $f \in F^{(n)}$  and consider the following (constrained) optimization problem<sup>1</sup>:

$$\|f\| \rightarrow \min \tag{1}$$

$$f(p_1(d), p_2(d), \dots, p_n(d)) = p_0(d), \quad d \in D \tag{2}$$

**Theorem 1.** *If  $n \geq 1$ , a predicate  $P_0$  is expressible in the algebra  $APr_{P_1, \dots, P_n}(D)$  if and only if on the set  $F^{(n)}$  the problem (1)-(2) has an optimal solution which is a short function.*

<sup>1</sup> If one interprets partiality in terms as possibility, minimization of  $\|f\|$  may be related to the principle of minimum specificity of D. Dubois et al. from possibility theory, or other similar principles.

## 4 Proof of the Main Result

Denote for all  $x, y \in \{-1, 0, 1\}$ :

$$\begin{aligned}\neg x &= -x \\ \sim x &= 1 - |x| \\ x^{[y]} &= \begin{cases} x, & \text{if } y = 1 \\ \sim x, & \text{if } y = 0 \\ \neg x, & \text{if } y = -1 \end{cases}\end{aligned}$$

**Lemma 1.**  $\rho_n(\bar{x}, \bar{y}) = 1 - \min_{i=1}^n x_i^{[y_i]}$  for every  $n \geq 1$  and  $\bar{x}, \bar{y} \in \{-1, 0, 1\}^n$ .

*Proof.* It is easy to see that for all  $x, y \in \{-1, 0, 1\}$ :

$$x^{[y]} = 1 - |x - y|$$

Then  $\rho_n(\bar{x}, \bar{y}) = \max_{i=1}^n |x_i - y_i| = \max_{i=1}^n (1 - x_i^{[y_i]}) = 1 - \min_{i=1}^n x_i^{[y_i]}$ .  $\square$

Consider  $\{-1, 0, 1\}$  as a lattice with operations:

$$x \vee y = \max(x, y);$$

$$x \wedge y = \min(x, y).$$

Below we will assume that in expressions involving operations on  $\{-1, 0, 1\}$  the operation  $x^{[y]}$  has the highest priority, and is followed (by priority) by the unary operations  $\neg, \sim$ , which are followed by the binary operations  $\wedge$  and  $\vee$ . As usual, among  $\wedge, \vee$ , the operation  $\wedge$  has higher priority.

**Lemma 2.** For each short function  $f \in F^{(n)}$  and  $\bar{x} \in \{-1, 0, 1\}^n$ :

$$f(\bar{x}) = \hat{f}(\bar{x}) \wedge f_{\neq 0}(\bar{x}) \vee \neg f_{\neq 0}(\bar{x})$$

where

$$\begin{aligned}\hat{f}(\bar{x}) &= \begin{cases} \bigvee_{\bar{y}: f(\bar{y})=1} \bigwedge_{i=1}^n x_i^{[y_i]}, & \text{if } \exists \bar{y} f(\bar{y}) = 1 \\ -1, & \text{otherwise} \end{cases} \\ f_{\neq 0}(\bar{x}) &= \begin{cases} \bigvee_{\bar{y}: f(\bar{y}) \neq 0} \bigwedge_{i=1}^n \sim (x_i^{[y_i]} \wedge \sim x_i^{[y_i]}) \wedge \sim \sim x_i^{[y_i]}, & \text{if } \exists \bar{y} f(\bar{y}) \neq 0 \\ 0, & \text{otherwise.} \end{cases}\end{aligned}$$

*Proof.* It is easy to see that for each  $x, y \in \{-1, 0, 1\}$ :

$$\sim (x^{[y]} \wedge \sim x^{[y]}) \wedge \sim \sim x^{[y]} = \begin{cases} 1, & \text{if } x = y \\ 0, & \text{if } x \neq y. \end{cases}$$

Then

$$f_{\neq 0}(\bar{x}) = \begin{cases} 1, & \text{if } f(\bar{x}) \neq 0 \\ 0, & \text{if } f(\bar{x}) = 0. \end{cases}$$

By Lemma 1,

$$\hat{f}(\bar{x}) = \begin{cases} \bigvee_{\bar{y}:f(\bar{y})=1} (1 - \rho_n(\bar{x}, \bar{y})), & \text{if } \exists \bar{y} f(\bar{y}) = 1, \\ -1, & \text{otherwise.} \end{cases}$$

If  $f(\bar{x}) = 1$ , then  $\hat{f}(\bar{x}) = 1$  and  $f_{\neq 0}(\bar{x}) = 1$ , so  $\hat{f}(\bar{x}) \wedge f_{\neq 0}(\bar{x}) \vee \neg f_{\neq 0}(\bar{x}) = 1$ .

If  $f(\bar{x}) = 0$ , then  $f_{\neq 0}(\bar{x}) = 0$ , so

$$\hat{f}(\bar{x}) \wedge f_{\neq 0}(\bar{x}) \vee \neg f_{\neq 0}(\bar{x}) = (\hat{f}(\bar{x}) \wedge 0) \vee 0 = 0.$$

If  $f(\bar{x}) = -1$ , then for each  $\bar{y}$  such that  $f(\bar{y}) = 1$  we have  $\rho_n(\bar{x}, \bar{y}) \geq |f(\bar{x}) - f(\bar{y})| = 2$  which implies that  $1 - \rho_n(\bar{x}, \bar{y}) = -1$ . Then  $\hat{f}(\bar{x}) = -1$  and  $f_{\neq 0}(\bar{x}) = 1$ , so  $\hat{f}(\bar{x}) \wedge f_{\neq 0}(\bar{x}) \vee \neg f_{\neq 0}(\bar{x}) = -1$ .

Thus

$$f(\bar{x}) = \hat{f}(\bar{x}) \wedge f_{\neq 0}(\bar{x}) \vee \neg f_{\neq 0}(\bar{x}).$$

□

**Lemma 3.** *The set of all short functions from  $F$  is a precomplete class in  $F$  and is the functional closure of the set  $\{f_0, f_1, f_2, f_3, f_4\}$ , where  $f_0 \in F^{(0)}$ ,  $f_1, f_2 \in F^{(1)}$ ,  $f_3, f_4 \in F^{(2)}$  and  $f_0 = 0$ ,  $f_1(x) = -x$ ,  $f_2(x) = 1 - |x|$ ,  $f_3(x, y) = \max(x, y)$ ,  $f_4(x, y) = \min(x, y)$ .*

*Proof.* Denote by  $S$  the set of all short functions from  $F$ . In accordance with its definition, a short function from  $F$  can be alternatively characterized as a function  $\{-1, 0, 1\}^n \rightarrow \{-1, 0, 1\}$  ( $n \geq 0$ ) which does not change sign on each of the sets  $\prod_{i=1}^n \{0, a_i\}$ , where  $a_1, \dots, a_n \in \{-1, 1\}^n$ . In the terminology of [18], such functions correspond to the precomplete class  $T_{\mathcal{E}_1, 1}^3$  of functions for which the image of the product of sets, 1-equivalent to  $\mathcal{E}_1$  is a subset of a set, 1-equivalent to  $\mathcal{E}_1$ , where two sets are 1-equivalent, if their symmetric difference has no more than 1 element. Thus  $S$  is a precomplete class in  $F$ . Obviously,  $\{f_0, f_1, f_2, f_3, f_4\} \subseteq S$ . On the other hand, since the constant function with value  $-1$  is expressible as  $f_1 \circ f_2 \circ f_0$ , from Lemma 2 and the definition of  $x^{[y]}$  it follows that each  $f \in S$  can be expressed as a composition of elements of  $\{f_0, f_1, f_2, f_3, f_4\}$  and of projections  $\pi_k^n(x_1, \dots, x_n) = x_k$  ( $n \geq 1$ ,  $k = 1, 2, \dots, n$ ). Thus  $S$  is the functional closure of  $\{f_0, f_1, f_2, f_3, f_4\}$ . □

**Lemma 4.** *For each  $P, Q : D \rightarrow \{T, F\}$  and  $d \in D$  we have:*

$$\begin{aligned} \Phi(\perp)(d) &= 0 \\ \Phi(\neg P)(d) &= -(\Phi(P)(d)) \\ \Phi(\sim P)(d) &= 1 - |\Phi(P)(d)| \\ \Phi(P \vee Q)(d) &= \max(\Phi(P)(d), \Phi(Q)(d)) \\ \Phi(P \wedge Q)(d) &= \min(\Phi(P)(d), \Phi(Q)(d)) \end{aligned}$$

*Proof.* Follows immediately from the definition  $\Phi$  and operations  $\neg, \sim, \vee, \wedge$  on partial predicates. □

Let  $M^{(n)}$  be the set of all short functions from  $F^{(n)}$ .

**Lemma 5.** *The problem (1)-(2) has an optimal solution on  $F^{(n)}$  if and only if  $p_0$  is continuous in the initial topology on  $D$  induced by  $p_1, \dots, p_n$  (where the codomain of  $p_i$ ,  $\{-1, 0, 1\}$ , is considered as a discrete space).*

*Proof.* “If”: assume that  $p_0$  is continuous in the initial topology on  $D$  induced by  $p_1, \dots, p_n$ . Then there exists  $f \in F^{(n)}$  such that  $p_0(d) = f(p_1(d), \dots, p_n(d))$  for all  $d \in D$ . Then since the set  $F^{(n)}$  is finite, the problem (1)-(2) has an optimal solution on  $F^{(n)}$ .

“Only if”: assume that the problem (1)-(2) has an optimal solution  $f \in F^{(n)}$ . Then  $p_0(d) = f(p_1(d), \dots, p_n(d))$  for all  $d \in D$ , so  $p_0$  is continuous in the initial topology on  $D$  induced by  $p_1, \dots, p_n$ .  $\square$

**Lemma 6.** *If the problem (1)-(2) has an optimal solution on  $F^{(n)}$ , then this solution is unique.*

*Proof.* Assume that the problem (1)-(2) has optimal solutions  $f, g \in F^{(n)}$ . Then  $\|f\| = \|g\|$  and  $f(p_1(d), \dots, p_n(d)) = p_0(d) = g(p_1(d), \dots, p_n(d))$  for all  $d \in D$ .

Suppose that  $f \neq g$ . Then there exists  $\bar{x}^* = (x_1^*, \dots, x_n^*) \in \{-1, 0, 1\}^n$  such that  $f(\bar{x}^*) \neq g(\bar{x}^*)$ .

Consider the case when  $f(\bar{x}^*) \neq 0$ . Let us define a function  $h \in F^{(n)}$  as follows:  $h(\bar{x}) = f(\bar{x})$ , if  $\bar{x} \neq \bar{x}^*$ , and  $h(\bar{x}) = 0$ , if  $\bar{x} = \bar{x}^*$ . Then for all  $d \in D$ ,  $(p_1(d), \dots, p_n(d)) \neq \bar{x}^*$ , so  $h(p_1(d), \dots, p_n(d)) = p_0(d)$ . Moreover,  $\|h\| = \|f\| - |f(\bar{x}^*)| = \|f\| - 1 < \|f\|$  which contradicts the assumption that  $f$  is an optimal solution of (1)-(2).

Consider the case when  $f(\bar{x}^*) = 0$ . Then  $|g(\bar{x}^*)| = 1$ . Let us define a function  $h \in F^{(n)}$  as follows:  $h(\bar{x}) = g(\bar{x})$ , if  $\bar{x} \neq \bar{x}^*$ , and  $h(\bar{x}) = 0$ , if  $\bar{x} = \bar{x}^*$ . Then for all  $d \in D$ ,  $(p_1(d), \dots, p_n(d)) \neq \bar{x}^*$ , so  $h(p_1(d), \dots, p_n(d)) = p_0(d)$ . Moreover,  $\|h\| = \|g\| - |g(\bar{x}^*)| = \|g\| - 1 < \|g\|$  which contradicts the assumption that  $g$  is an optimal solution of (1)-(2).

Thus  $f = g$ . So if the problem (1)-(2) has an optimal solution on  $F^{(n)}$ , then this solution is unique.  $\square$

**Lemma 7.** *Let  $f \in M^{(n)}$ ,  $g \in F^{(n)}$  and  $g(\bar{x}) \in \{f(\bar{x}), 0\}$  for each  $\bar{x} \in \{-1, 0, 1\}^n$ . Then  $g \in M^{(n)}$ .*

*Proof.* Let  $\bar{x}, \bar{y} \in \{-1, 0, 1\}^n$ . Consider the following cases.

- 1)  $g(\bar{x}) = f(\bar{x}), g(\bar{y}) = f(\bar{y})$ . Then  $|g(\bar{x}) - g(\bar{y})| = |f(\bar{x}) - f(\bar{y})| \leq \rho(\bar{x}, \bar{y})$ .
- 2)  $g(\bar{x}) = f(\bar{x}), g(\bar{y}) = 0$ . Then  $|g(\bar{x}) - g(\bar{y})| = |f(\bar{x})| \leq \rho(\bar{x}, \bar{y})$ , if  $\bar{x} \neq \bar{y}$ , and  $|g(\bar{x}) - g(\bar{y})| = 0 \leq \rho(\bar{x}, \bar{y})$ , if  $\bar{x} = \bar{y}$ .
- 3)  $g(\bar{x}) = 0, g(\bar{y}) = f(\bar{y})$ . Then  $|g(\bar{x}) - g(\bar{y})| = |f(\bar{y})| \leq \rho(\bar{x}, \bar{y})$ , if  $\bar{x} \neq \bar{y}$ , and  $|g(\bar{x}) - g(\bar{y})| = 0 \leq \rho(\bar{x}, \bar{y})$ , if  $\bar{x} = \bar{y}$ .
- 4)  $g(\bar{x}) = 0, g(\bar{y}) = 0$ . Then  $|g(\bar{x}) - g(\bar{y})| \leq \rho(\bar{x}, \bar{y})$ .

Thus  $g \in M^{(n)}$ .  $\square$

**Lemma 8.** *The problem (1)-(2) has an optimal solution on  $M^{(n)}$  if and only if it has an optimal solution on  $F^{(n)}$  which belongs to  $M^{(n)}$ .*



*Proof.* “If”: assume that the problem (1)-(2) has an optimal solution  $f \in F^{(n)}$  which belongs to  $M^{(n)}$ . Then  $f(p_1(d), p_2(d), \dots, p_n(d)) = p_0(d)$  for all  $d \in D$ . Moreover, for each  $g \in M^{(n)}$  such that  $g(p_1(d), p_2(d), \dots, p_n(d)) = p_0(d)$  for all  $d \in D$ , we have  $g \in F^{(n)}$ , so  $\|f\| \leq \|g\|$ . So  $f$  is an optimal solution of (1)-(2) on  $M^{(n)}$ .

“Only if”: assume that the problem (1)-(2) has an optimal solution  $f$  on  $M^{(n)}$ . Then  $f(p_1(d), p_2(d), \dots, p_n(d)) = p_0(d)$  for all  $d \in D$ . Then since  $F^{(n)}$  is finite, the problem (1)-(2) has an optimal solution on  $F^{(n)}$ . By Lemma 6, the problem (1)-(2) has a unique optimal solution of  $F^{(n)}$ . Denote it as  $g$ . Then  $g(p_1(d), p_2(d), \dots, p_n(d)) = p_0(d)$  for all  $d \in D$  and  $\|g\| \leq \|f\|$ . Let us define a function  $h \in F^{(n)}$  as follows: for each  $\bar{x} \in \{-1, 0, 1\}^n$ ,  $h(\bar{x}) = f(\bar{x})$ , if  $g(\bar{x}) \neq 0$ , and  $h(\bar{x}) = g(\bar{x})$ , if  $g(\bar{x}) = 0$ . Then for all  $d \in D$ ,  $h(p_1(d), \dots, p_n(d)) = p_0(d)$ . Moreover,  $h \in M^{(n)}$  by Lemma 7. Then  $\|h\| = \|f\|$ , so for each  $\bar{x}$  such that  $g(\bar{x}) = 0$  we have  $f(\bar{x}) = 0$ . Then  $\|f\| \leq \|g\|$ . Since  $\|g\| \leq \|f\|$  as mentioned above, we have  $\|f\| = \|g\|$ . The  $f$  is an optimal solution of (1)-(2) on  $F^{(n)}$  and  $f$  belongs to  $M^{(n)}$ .  $\square$

Now we can give a proof of the main Theorem 1 from the previous section.

*Proof (of Theorem 1).* “If”: assume that the problem (1)-(2) has an optimal solution on the set  $F^{(n)}$  which is a short function. Denote by  $f$  such a solution. Then we have  $p_0(d) = f(p_1(d), p_2(d), \dots, p_n(d))$  for all  $d \in D$ . By Lemma 3,  $f$  belongs to the functional closure of  $\{f_0, f_1, f_2, f_3, f_4\}$ , where  $f_i$  are defined as in Lemma 3. From Lemma 4 it follows that  $p_0(d) = \Phi(P)(d)$  for all  $d \in D$  for some predicate  $P : D \rightarrow \{T, F\}$  expressible in the algebra  $(D \rightarrow \{T, F\}; \vee, \wedge, \neg, \sim, \perp, P_1, P_2, \dots, P_n)$ . Since  $n \geq 1$  and the predicate  $\perp$  can be expressed as  $\sim P_1 \wedge \sim \sim P_1$ , we conclude that  $P$  is expressible in the algebra  $APr_{P_1, \dots, P_n}(D)$ . Then  $\Phi(P_0)(d) = \Phi(P)(d)$  for all  $d \in D$ . Then the definition of  $\Phi$  implies that  $P_0 = P$ , so  $P_0$  is expressible in  $APr_{P_1, \dots, P_n}(D)$ .

“Only if”: assume that a predicate  $P_0$  is expressible in algebra  $APr_{P_1, \dots, P_n}(D)$ . Then Lemma 4 implies that  $\Phi(P_0)(d) = f(\Phi(P_1)(d), \Phi(P_2)(d), \dots, \Phi(P_n)(d))$  for all  $d \in D$  for some function  $f \in F^{(n)}$  which belongs to the functional closure of  $\{f_0, f_1, f_2, f_3, f_4\}$ , where  $f_i$  are defined as in Lemma 3. Then by Lemma 3,  $f$  is a short function and  $p_0(d) = f(p_1(d), \dots, p_n(d))$  for all  $d \in D$ . Then since  $M^{(n)} \subseteq F^{(n)}$  is a finite set, the problem (1)-(2) has an optimal solution on the set  $M^{(n)}$ . Then Lemma 8 implies that the problem (1)-(2) has an optimal solution on  $F^{(n)}$  which is a short function.  $\square$

Note that the problem (1)-(2) has the following addition property.

**Lemma 9.** *If the problem (1)-(2) has an optimal solution on  $M^{(n)}$ , then this solution is unique.*

*Proof.* Assume that  $f, g$  are optimal solutions of (1)-(2) on  $M^{(n)}$ . Then by Lemma 8, (1)-(2) has an optimal solution on  $F^{(n)}$  which belongs to  $M^{(n)}$ . By Lemma 6 this solution is unique. Denote it as  $h$ . Then  $\|h\| \leq \|f\|$  and  $\|h\| \leq \|g\|$ . Then  $h$  is an optimal solution of (1)-(2) on  $M^{(n)}$  and  $\|h\| = \|f\| = \|g\|$ . Then  $f, g$  are optimal solutions of (1)-(2) on  $F^{(n)}$ . Then by Lemma 6,  $f = g$ .  $\square$

## 5 Example

In this example of application of the main result of the paper we will use the notation and terminology of the composition-nominative approach to program formalization [16, 17] and [7, 6, 5].

Let  $v$  be a fixed name,  $V = \{v\}$ ,  $A = \{T, F\}$ .

Let  $D = {}^V A$  be the set of named sets on  $V$  which take values in  $A$ . Then

$$D = \{\ [], [v \mapsto T], [v \mapsto F] \}.$$

Let  $P_1$  be a partial predicate on  $D$  such that

$$P_1(d) \cong (v \Rightarrow (d))$$

where  $v \Rightarrow$  is the denaming operation [16, 17] (which has undefined value, if  $v \notin \text{dom}(d)$ ).

Let  $P_0$  be a partial predicate on  $D$  such that

$$P_0(d) = \begin{cases} T, & \text{if } v \Rightarrow (d) \uparrow; \\ F, & \text{if } v \Rightarrow (d) \downarrow. \end{cases}$$

Let us check if  $P_0$  is expressible in the algebra

$$APr_{P_1}(D) = (D \xrightarrow{\sim} \{T, F\}; \vee, \wedge, \neg, \sim, P_1).$$

Let  $p_i : D \rightarrow \{-1, 0, 1\}$ ,  $i = 0, 1$  be functions such that

$$p_i(d) = \begin{cases} 1, & \text{if } P_i(d) \downarrow = T, \\ 0, & \text{if } P_i(d) \uparrow, \\ -1, & \text{if } P_i(d) \downarrow = F. \end{cases}$$

Then

$$p_1(d) = \begin{cases} 1, & \text{if } v \Rightarrow (d) \downarrow = T, \\ 0, & \text{if } v \Rightarrow (d) \uparrow, \\ -1, & \text{if } v \Rightarrow (d) \downarrow = F. \end{cases}$$

$$p_0(d) = \begin{cases} -1, & \text{if } v \Rightarrow (d) \downarrow = T, \\ 1, & \text{if } v \Rightarrow (d) \uparrow, \\ -1, & \text{if } v \Rightarrow (d) \downarrow = F. \end{cases}$$

The initial topology on  $D$  induced by  $p_1$  is the power set of  $D$ , so  $p_0$  is continuous. We have

$$p_0(\{d \in D \mid p_1(d) = -1\}) = \{-1\}$$

$$p_0(\{d \in D \mid p_1(d) = 0\}) = \{1\}$$

$$p_0(\{d \in D \mid p_1(d) = 1\}) = \{-1\}$$

Then a function with the graph

$$\{(-1, -1), (0, 1), (1, -1)\}$$

is the unique optimal solution of the problem (1)-(2), but it is, obviously, not a short function. Then Theorem 1 implies that  $P_0$  is not expressible in the algebra

$$APr_{P_1}(D) = (D \xrightarrow{\sim} \{T, F\}; \vee, \wedge, \neg, \sim, P_1).$$

## 6 Conclusion

We have investigated the question of expressibility of partial predicates in the Kleene algebra extended with the composition of predicate complement and have given a necessary and sufficient condition of this expressibility in terms of the existence of an optimal solution of a special optimization problem. The obtained results may be useful for development of (semi-)automatic deduction tools for an extension of the Floyd-Hoare logic for the case of partial pre- and postconditions.

## References

1. Floyd, R.: Assigning meanings to programs. *Mathematical aspects of computer science* **19**(19-32) (1967)
2. Hoare, C.: An axiomatic basis for computer programming. *Commun. ACM* **12**(10), 576–580 (1969)
3. Ivanov, I., Kornilowicz, A., Nikitchenko, M.: Implementation of the composition-nominative approach to program formalization in mizar. *Computer Science Journal of Moldova* **26**, 59–76
4. Ivanov, I., Kornilowicz, A., Nikitchenko, M.: Formalization of nominative data in mizar. pp. 82–85. *Proceedings of TAAPSD 2015, 23-26 December 2015, Taras Shevchenko National University of Kyiv, Ukraine* (2015)
5. Ivanov, I.: An abstract block formalism for engineering systems. In: Ermolayev, V., Mayr, H.C., Nikitchenko, M., Spivakovsky, A., Zholtkevych, G., Zavileysky, M., Kravtsov, H., Kobets, V., Peschanenko, V.S. (eds.) *Proceedings of the 9th International Conference on ICT in Education, Research and Industrial Applications: Integration, Harmonization and Knowledge Transfer, Kherson, Ukraine, June 19-22, 2013*. CEUR Workshop Proceedings, vol. 1000, pp. 448–463. CEUR-WS.org (2013)
6. Ivanov, I.: On existence of total input-output pairs of abstract time systems. In: Ermolayev, V., Mayr, H.C., Nikitchenko, M., Spivakovsky, A., Zholtkevych, G. (eds.) *Information and Communication Technologies in Education, Research, and Industrial Applications*. *Communications in Computer and Information Science*, vol. 412, pp. 308–331. Springer International Publishing, Cham (2013)
7. Ivanov, I.: On representations of abstract systems with partial inputs and outputs. In: Gopal, T.V., Agrawal, M., Li, A., Cooper, S.B. (eds.) *Theory and Applications of Models of Computation*. *Lecture Notes in Computer Science*, vol. 8402, pp. 104–123. Springer International Publishing, Cham (2014)
8. Ivanov, I., Nikitchenko, M.: Inference rules for the partial floyd-hoare logic based on composition of predicate complement. In: Ermolayev, V., Suárez-Figueroa, M.C., Yakovyna, V., Mayr, H.C., Nikitchenko, M., Spivakovsky, A. (eds.) *Information and Communication Technologies in Education, Research, and Industrial Applications*. pp. 71–88. Springer International Publishing, Cham (2019)
9. Kornilowicz, A., Ivanov, I., Nikitchenko, M.: Kleene algebra of partial predicates. *Formalized Mathematics* **26**, 11–20 (2018)
10. Kornilowicz, A., Kryvolap, A., Nikitchenko, M., Ivanov, I.: An approach to formalization of an extension of Floyd-Hoare logic. In: *Proceedings of the 13th International Conference on ICT in Education, Research and Industrial Applications. Integration, Harmonization and Knowledge Transfer, Kyiv, Ukraine, May 15-18, 2017*. pp. 504–523 (2017)

11. Kornilowicz, A., Kryvolap, A., Nikitchenko, M., Ivanov, I.: Formalization of the algebra of nominative data in mizar. In: Ganzha, M., Maciaszek, L.A., Paprzycki, M. (eds.) Proceedings of the 2017 Federated Conference on Computer Science and Information Systems. ACSIS, vol. 11, pp. 237–244 (2017)
12. Kornilowicz, A., Kryvolap, A., Nikitchenko, M., Ivanov, I.: Formalization of the Nominative Algorithmic Algebra in Mizar, *Advances in Intelligent Systems and Computing*, vol. 656, pp. 176–186. Springer International Publishing, Cham (2018)
13. Kryvolap, A., Nikitchenko, M., Schreiner, W.: Extending Floyd-Hoare logic for partial pre- and postconditions. In: Ermolayev, V., Mayr, H., Nikitchenko, M., Spivakovsky, A., Zholtkevych, G. (eds.) *Information and Communication Technologies in Education, Research, and Industrial Applications, Communications in Computer and Information Science*, vol. 412, pp. 355–378. Springer International Publishing (2013)
14. Nikitchenko, M., Kryvolap, A.: Properties of inference systems for Floyd-Hoare logic with partial predicates. *Acta Electrotechnica et Informatica* **13**(4), 70–78 (2013)
15. Nikitchenko, M., Ivanov, I., Kornilowicz, A., Kryvolap, A.: Extended Floyd-Hoare logic over relational nominative data. In: Bassiliades, N., Ermolayev, V., Fill, H.G., Yakovyna, V., Mayr, H.C., Nikitchenko, M., Zholtkevych, G., Spivakovsky, A. (eds.) *Information and Communication Technologies in Education, Research, and Industrial Applications*. pp. 41–64. Springer International Publishing, Cham (2018)
16. Nikitchenko, N.S.: A composition nominative approach to program semantics. Tech. rep., IT-TR 1998-020, Technical University of Denmark (1998)
17. Skobelev, V., Nikitchenko, M., Ivanov, I.: On algebraic properties of nominative data and functions. In: Ermolayev, V., Mayr, H., Nikitchenko, M., Spivakovsky, A., Zholtkevych, G. (eds.) *Information and Communication Technologies in Education, Research, and Industrial Applications, Communications in Computer and Information Science*, vol. 469, pp. 117–138. Springer International Publishing (2014)
18. Yablonskii, S.: Functional constructions in a k-valued logic. *Trudy Mat. Inst. Steklov.* **51**, 5–142 (1958)

# Computational Modeling and Structural Stability

Alexander Weissblut<sup>1</sup>[0000-0002-1476-8884]

<sup>1</sup>Kherson State University, 27, Universitetska st., Kherson, 73000 Ukraine  
veitsblit@gmail.com

**Abstract.** The structural stability of a mathematical model with respect to small changes is a necessary condition for its correctness. The same condition is also necessary for the applicability of numerical methods, a computational experiment. But after S. Smale's works it became clear that in smooth dynamics the system of a general form is not structurally stable, therefore there is no strict mathematical basis for modeling and computational analysis of systems. The contradiction appeared in science: according to physicists dynamics is simple and universal. The paper proposes a solution to this problem based on the construction of dynamic quantum models (DQM). DQM is a perturbation of a smooth dynamical system by a Markov cascade (time is discrete). The dynamics obtained in this way are simpler than smooth dynamics: the structurally stable DQM realizations are everywhere dense and open on the set of all DQM realizations. This dynamics in contrast to the classical one has a clear structural theory, which makes it possible to construct effective algorithms for study of concrete systems. For example this paper shows the use of computer simulation for rigorous proof of hyperbolicity of the Henon system attractor. On the other hand, when fluctuations tend to zero, i.e. in the semiclassical limit, the dynamics of the DQM goes into the initial smooth dynamics. In this paper the equivalence of structural stability and hyperbolicity for smooth discrete dynamical systems is established along this path.

**Keywords:** modeling, computer simulation, structural stability, dynamical system, dynamic quantum model, Markov cascade, attractor.

## 1 Introduction

Computational modeling derives from two steps: (i) modeling, i.e. finding a model description of a real system, and (ii) solving the resulting model equations using computational methods [1]. Computational modeling has been used in physics, chemistry and related engineering for many decades because in practice hardly any model equations of systems of interest can be solved analytically, and this is where the computer comes in [2].

However, if an arbitrarily small perturbation of the model leads to a qualitatively different picture of the dynamics, then such a model is not applicable to the real process: strictly speaking, perturbations are included in the definition of a model. Therefore traditionally the stability of a mathematical model with respect to relatively small changes is a necessary condition for its correctness [3]. The same stability condition is

necessary for applicability of numerical methods, computational experiments since they inevitably lead to errors of discretization and rounding in calculations [4].

The qualitative invariance of a mathematical model under small perturbations is usually called structural stability. This formally means equivalence, in some exact sense, between the model and its small enough perturbation. For the smooth dynamical systems (sets of differential or difference equations) this equivalence is usually a homeomorphism between the phase portraits of these systems. Such theory of a structural stability going back to H. Poincare, has been developed by A. Andronov and L. Pontrjagin in the case of small dimension of the phase space (1 or 2) [5]. However, the optimism generated by the successes of this theory disappeared after S. Smale's works [6]. It was shown in [7] that when the phase space has larger dimension, then there exist smooth dynamic systems whose neighborhoods do not contain any structurally stable system. For the theory of smooth dynamical systems (its old name is the qualitative theory of differential equations) this result has the same value as Liouville's theorem on insolvability of the differential equations in quadratures has for the theory of their integration. Namely, it shows that the problem of full topological classification of smooth dynamical systems is hopeless. This means also that there is no strict mathematical basis for modeling and computational analysis. The contradiction has appeared in science, because physicists believe that the dynamics is simple and universal [8].

The paper proposes solution to this problem, based on the construction of dynamic quantum models (DQM). It turns out that taking into account random fluctuations, necessary for the transition to the quantum model of reality, allows us to return in fact to the simple picture of A. Poincare's dynamics: a dense set of structurally stable systems.

DQM is so named because for Hamiltonian systems it is simply related to the corresponding Schrödinger equation, and its construction is the basis of the method for solving spectral problems [9]. But the definition of DQM is not formally related to Hamiltonian systems; it is defined for any ordinary differential equation or any diffeomorphism on any smooth Riemannian manifold.

The structural stability of the general form DQM opens the way to a mathematically grounded numerical analysis of the dynamics. As an example, this paper shows the use of computer simulation for rigorous proof of hyperbolicity of the Henon system attractor [10] at certain values of parameters. DQM is the natural basis for solving the traditional problems of machine learning [11].

On the other hand, when fluctuations tend to zero, i.e. in the semiclassical limit, the dynamics of the DQM goes into a more complex initial smooth dynamics. The old problem – the equivalence of structural stability and hyperbolicity for smooth discrete dynamical systems [12] is established by this way in this paper.

The **paper goal** is 1) to build the foundations of the theory of dynamic quantum models (DQM); 2) to demonstrate the application of this theory for computer research of concrete systems and for solving traditional problems of the theory of smooth dynamical systems.

The paper is organized as follows: in part 2 we synthesize the dynamic quantum models (DQM), in section 2.2 we define the DQM attractor, show the uniqueness of this definition and establish properties of the DQM attractor; in part 3 we show that structurally stable realizations of DQM are dense and open on the set of all its

realizations; in part 4 we demonstrate the use of computer modeling for rigorous proof of hyperbolicity of the attractor of Henon system; part 5 concludes.

We had to omit proofs of some theorems in order to fit the paper format.

## 2 The Dynamic Quantum Model: Basic Definitions

### 2.1 DQM Definition

Let  $p(x)$  be an  $n$ -dimensional smooth vector field on an  $n$ -dimensional smooth Riemannian manifold  $M$ , where  $x(x_1, x_2, \dots, x_n)$  are local Euclidean coordinates on  $M$ ,  $p_i(x) \in C^\infty(R^n)$  ( $i=1, \dots, n$ ). On each phase curve  $x(t) \in M$  of the dynamical system generated by this vector field

$$\frac{dx_i}{dt} = p_i(x), \quad (i=1, \dots, n) \quad (1)$$

consider the integral of the “shortened action”  $s(t) = \int_{x(t)} p(x) dx = \int_0^t \|p(\tau)\|^2 d\tau$ ,

where  $\|p(\tau)\|^2 = \sum_{i=1}^n p_i^2(\tau)$ . The value of  $s(t)$  on each curve  $x(t)$ , which is different from a fixed point, is diffeomorphically expressed in  $t$  and is called “optical time”. Let  $\rho$  be a metric such that  $s(t) = \int_{x(t)} d\rho: d\rho = \|p(t)\|^2 dt$ . The following is the heuristic derivation or explanation of the definition of dynamic quantum model (Definition 1).

So, the distance  $d$  traveled by a point along the path of (1) during the time  $\Delta t$  is equal to  $d = \int_0^{\Delta t} \|p(\tau)\| d\tau = \|p(t_c)\| \cdot \Delta t$ , where  $p_c = p(t_0)$  is the average value

( $0 \leq t_0 \leq \Delta t$ ). (Of course this is with a single bypass of trajectory during  $\Delta t$ : turning points are the special case). Further, we assume that the fluctuations generate “white noise”  $\xi(t)$ , acting on the configuration space with the dispersion  $D\xi(t) = \sigma^2 t$ , where the diffusion coefficient  $\sigma^2$  is constant over the considered time interval. It will take some time  $\Delta t$ , until the point moves to a distance  $d$  from the initial position, which exceeds the mean square error caused by  $\xi(t)$  during the time  $\Delta t$ , i.e.  $\|p_c\| \Delta t$  will exceed  $\sqrt{\sigma^2 \Delta t}$ . With such a minimal  $\Delta t$   $\|p_c\| \Delta t = \sigma \sqrt{\Delta t}$ , whence  $\sigma^2 = \|p_c\|^2 \Delta t$  and therefore

$$\Delta t = \frac{\sigma^2}{\|p_c\|^2}, \quad d = \|p_c\| \Delta t = \frac{\sigma^2}{\|p_c\|} \quad (2)$$

Here by assumption  $\Delta t$  is the minimal time interval after which it becomes possible to make a new measurement, the difference from which will exceed the error, i.e. get a significantly different measurement. Owing to (2)

$$\sigma^2 = \|p_c\|^2 \Delta t \approx \int_0^{\Delta t} \|p(\tau)\|^2 d\tau = s(\Delta t). \text{ Thus 1) the time interval between the}$$

nearest significant measurements is unchanged on the optical time scale and is equal to  $\sigma^2$ . (In other words, the distance between them in the metric  $\rho$  is equal to  $\sigma^2$ ). 2) During this time “white noise”  $\xi(t)$  generates an irremovable random error, the standard deviation of which is equal to the distance  $d$  between the nearest significant measurements along the trajectory.

So, a dynamic quantum model first shifts each point along the phase curve of a given dynamic system over the optical time  $\sigma^2$  (or  $\rho$  – length  $\sigma^2$ ), and then randomly shifts on a distance not exceeding the length of the trajectory from the original to the new point. The following rigorous definition summarizes this description. The definition of a dynamic quantum model is given for an arbitrary dynamic system (1) on an arbitrary compact Riemannian manifold  $M$ .

Let  $G$  be the shift map along the phase trajectories of (1) during the lag time  $\Delta t$ . Consider a smooth function  $q(y, z) \geq 0$  ( $y, z \in M$ ) such that

$$\|z - Gy\| \leq d(y), \quad \int_M q(y, z) dz = 1, \quad \left\| \int_M z q(y, z) dz - Gy \right\| \leq d(y), \quad (3)$$

where  $d(y) > 0$  is a continuous function on  $M$ . Here  $q(y, z)$  defines the density of “local random dissipation caused by white noise,” the numbers  $d(y)$  are assumed to be small. Of course, the function  $q(y, z)$  can also be assumed continuous, approximating it on  $M$  with a smooth function for any given accuracy. Then

**Definition 1.** The Markov process with the transition function

$$P(y, A) = \int_A q(y, z) dz \quad (A \subset M) \quad (4)$$

is called the dynamic quantum model (DQM) for the dynamic system (1). Given the initial distribution, we obtain a Markov process  $P$  with this initial distribution and the transition function  $P(y, A)$ : if  $\mu_t$  is the distribution at time  $t$ ,  $\Delta t$  is the lag between the two nearest measurements, then the DQM sets new distribution  $P(\mu_t) = \mu_{t+\Delta t}$  at time  $t + \Delta t$ .



Thus, based on the differential equations (1), we arrive at difference equations with a lag of at least  $\sigma^2$  on the optical time scale. At first glance, the DQM may surprise with the discreteness of time: in the traditional model of quantum mechanics errors are explicitly taken into account only for spatial variables. But, as can be seen from the deduction, the discreteness of the measurement process is an inevitable consequence of the unavoidable errors of coordinates and pulses. Indeed, to measure time ultimately requires a clock or other device in which readings on a scale are measured in proportion to time at a certain speed. But if these readings and speed are determined inaccurately, then the time is also known only with some error.

**Definition 2.** Let  $\Delta_i$  be cells with a diameter  $\varepsilon$  of some partition of the phase space of a dynamical system and  $\mu_0$  is the initial state. Then the Markov chain with transition probabilities from  $\Delta_i$  to  $\Delta_j$  equal to  $p_{ij} = \frac{1}{\mu_0(\Delta_i)} \int_{y \in \Delta_i} P(y, \Delta_j) d\mu_0$  will be called the  $\varepsilon$ -discretization of DQM with transition function  $P(y, A)$  and initial state  $\mu_0$ .

## 2.2 DQM Attractor

Attractor is the key concept of the theory of dynamical systems; its physical meaning is that it is “the space of steady-state regimes”. The point of the phase space is contained in the attractor if it belongs to the carrier of the “stationary state of the system”, i.e. to a measure not changing over time.

Let  $M$  be a compact phase space,  $P$  is some DQM on  $M$ .

**Definition 3.** The probability measure  $\mu$  on  $M$  will be called the stationary (equilibrium) state of DQM if  $P(\mu) = \mu$ . The DQM attractor is the union of the carriers of all stationary states.

**Theorem 1.** (Perron-Frobenius theorem for DQM). Let  $\Lambda \subset M$  be an invariant closed set of DQM  $P$  that does not contain its own invariant closed subsets (that is minimal with respect to  $P$ ). Then

1. there is a unique stationary state  $\mu$ , whose carrier is  $\Lambda$ . The state  $\mu$  is ergodic (that is the flow  $P$  is ergodic with respect to measure  $\mu$ ).
2. For any other state (probability measure)  $\nu$  on  $\Lambda$   $\lim_{n \rightarrow \infty} \frac{1}{n} \sum_{k=1}^n P^k \nu = \mu$ .
3. If  $\bar{\mu}_\varepsilon$  is a probabilistic stationary measure of some  $\varepsilon$ -discretization of the given DQM on  $\Lambda$  then  $\lim_{\varepsilon \rightarrow 0} \bar{\mu}_\varepsilon = \mu$ .

**Proof.** Let  $\Lambda \subset M$  be an invariant closed set of DQM that does not contain its own invariant closed subsets. Let  $\bar{\mu}_\varepsilon$  be a stationary measure of some discretization of the given DQM on  $\Lambda$  with cells of diameter  $\varepsilon$  (that is, a probability invariant measure of a Markov chain defined by Definition 3). On a compact subset  $\Lambda$  of the phase space

the set of probability measures  $R = R(\Lambda)$  forms a convex metrizable compact in the weak topology. Therefore in any sequence of measures  $\bar{\mu}_{\varepsilon_k}$  one can find a subsequence  $\bar{\mu}_{\varepsilon_n}$ , converging to some measure  $\bar{\mu}$  from  $R$ :  $\lim_{n \rightarrow \infty} \bar{\mu}_{\varepsilon_n} = \bar{\mu} \in R$  in the sense of the weak topology on  $R$ . Since  $P\bar{\mu}_{\varepsilon_n} - \bar{\mu}_{\varepsilon_n} \xrightarrow{\varepsilon_n \rightarrow 0} 0$  (in the sense of the weak topology) by virtue of definition 3, then  $P\bar{\mu} = \bar{\mu}$  i.e.  $\bar{\mu}$  is a stationary state of DQM. Since by the condition  $\Lambda$  does not contain non-empty proper invariant subsets of DQM (i.e. it is metrically transitive), then for any  $P$ -invariant measure on  $\Lambda$  the ergodic Neumann theorem holds: for any continuous function  $f$  on  $\Lambda$

$$L^2 - \lim_{n \rightarrow \infty} \frac{1}{n} \sum_{k=1}^n f(P^k) = \int f d\bar{\mu} \quad (5)$$

Since left side of this equality does not depend on the choice of a sequence of measures  $\bar{\mu}_{\varepsilon_k}$ , then any weakly convergent sequence  $\bar{\mu}_{\varepsilon_n}$  converges to the same measure  $\bar{\mu}$ . Therefore  $\lim_{\varepsilon \rightarrow 0} \mu_\varepsilon = \mu$  and it proves 3). Since (5) holds for any stationary state on  $\Lambda$ , then from (5) the uniqueness of an invariant measure  $\bar{\mu}$  also follows, which establishes 1). Finally, since for any other probability measure  $\nu$  on  $\Lambda$   $\lim_{n \rightarrow \infty} \frac{1}{n} \sum_{k=1}^n P^k \nu$  exists by virtue of (5) and is an invariant measure, then it coincides with  $\bar{\mu}$ , which proves 2), QED.

Obviously, there are only finitely many components of the DQM attractor  $\Lambda_k$  on  $M$ , that is such invariant subsets of the attractor that do not contain proper invariant non-empty subsets. On each component  $\Lambda_k$  of the DQM attractor there is a unique probability invariant measure  $\bar{\mu}_k$ :  $P\bar{\mu}_k = \bar{\mu}_k$ . The density of  $\bar{\mu}_k$  is positive on the interior of  $\Lambda_k$  by the definition of DQM. Any stationary state on  $M$  is a convex combination of stationary states  $\bar{\mu}_k$  on  $\Lambda_k$ .

Let  $G$  be shift map along the phase trajectories of (1) during the lag time of DQM.

**Definition 4.** For the DQM trajectory  $\omega$  for the time  $t_n$ :  $y_0, y_1, \dots, y_n$  its differential is  $D_n(\omega) = DG(y_n) \cdot \dots \cdot DG(y_1) \cdot DG(y_0)$  where  $DG(y_k)$  is the differential of  $G$  at the point  $y_k \in \Lambda$ ,  $k \leq n = 0, 1, \dots$ . For the DQM trajectory  $\omega$ :  $y_{-n}, \dots, y_{-1}, y_0$  differential  $D_n(\omega) = DG(y_n) \cdot \dots \cdot DG(y_1) \cdot DG(y_0)$  at  $n = 0, 1, \dots$ .

The measure  $\bar{\mu}$ , induced by the measure  $\mu$  in accordance with the Kolmogorov theorem [13], is defined on the space  $\Omega$  of DQM trajectories on the component  $\Lambda$  of the DQM attractor.

**Theorem 2.** Let  $\Lambda \subset M$  is a component of the DQM attractor of dimension  $m = \dim M$ . Then for DQM with sufficiently small  $d = \min_{y \in \Lambda} d(y)$  (where  $d(y) > 0$  are constants from (3))

1. for almost all under measure  $\bar{\mu}$  DQM trajectories  $\omega$  at any nonzero vector  $u \in R^m$  ( $\|u\| = 1$ ) there are limits

$$\lim_{n \rightarrow \pm\infty} \frac{1}{n} \ln \|D_n(\omega)u\| = \pm\lambda_r,$$

where  $r = 1, 2, \dots, s \leq m = \dim M$ .

2. At each point of each such trajectory  $\omega$ , the filtering of subspaces is uniquely defined:

$$\text{forward } L_1^+(y) \subset L_2^+(y) \subset \dots \subset L_s^+(y) = R^m$$

$$\text{and back } L_s^-(y) \subset \dots \subset L_2^-(y) \subset L_1^-(y) = R^m,$$

associated with the numbers  $\lambda_1 < \lambda_2 < \dots < \lambda_s$  so that

$$\lim_{n \rightarrow \infty} \frac{1}{n} \ln \|D_n(\omega)u\| = \lambda_r \Leftrightarrow u \in L_r^+(y) \text{ and } u \notin L_{r-1}^+(y),$$

$$\lim_{n \rightarrow -\infty} \frac{1}{n} \ln \|D_n(\omega)u\| = -\lambda_r \Leftrightarrow u \in L_r^-(y) \text{ and } u \notin L_{r+1}^-(y).$$

These filtrations are invariant with respect to the DQM differential. Exactly if  $y_n$  and  $y_{n+1}$  are consecutive points of the trajectory  $\omega$  at times  $t_n$  and  $t_{n+1}$  respectively then the differential  $DG(y_n)$  translates the filtering at the point  $y_n$  in the filtering at the point  $y_{n+1}$ .

**Proof.** Consider DQM on  $\Lambda$  as a random process  $X(t, \omega)$ , where  $t$  is discrete time,  $t = t_k, k = 0, \pm 1, \pm 2, \dots$ ,  $\omega$  is a DQM trajectory. Namely, for  $\eta_k \in M$  let  $\boldsymbol{\eta} = (\dots, \eta_{-k}, \dots, \eta_{-1}, \eta_0, \eta_1, \dots, \eta_k, \dots)$ . Then the DQM trajectory  $\omega = \omega(t, y_0)$  with an initial point  $y_0 \in M$  is the sequence  $X(t_0, \omega) = y_0, X(t_1, \omega) = y_1 = Gy_0 + \eta_0, X(t_2, \omega) = y_2 = Gy_1 + \eta_1, \dots, X(t_k, \omega) = y_k = Gy_{k-1} + \eta_{k-1}, \dots$ . (Here  $d$  is assumed to be so small that the addition of  $Gy_{k-1} + \eta_{k-1}$  when  $\|\eta_k\| \leq d$  performed on the local map of the manifold  $M$  in  $R^m$ ). Thus, the DQM trajectory  $\omega$  is defined uniquely by a sequence of vectors  $\boldsymbol{\eta}$  and an initial point  $y_0 : \omega = \omega(y_0, \boldsymbol{\eta})$ .

On the set  $\Omega$  of DQM trajectories  $X(t, \omega)$  on  $\Lambda$  induces the dynamic process  $T$  – the trajectory of the trajectories:  $T\omega_0 = \omega_1, T\omega_1 = \omega_2, \dots, T\omega_{k-1} = \omega_k, \dots$ . Namely if  $\omega_0 = \omega(y_0, \eta_0)$ , where  $y_0 = X(t_0, \omega_0)$ ,  $\eta_0 = (\dots, \eta_{-k}, \dots, \eta_{-1}, \eta_0, \eta_1, \dots, \eta_k, \dots)$  and  $\omega_1 = \omega(y_1, \eta_1)$ , then  $y_1 = Gy_0 + \eta_0 = X(t_1, \omega_0)$ ,  $\eta_1 = R\eta_0$ , where  $R$  is shift operator to the right. If  $\omega_2 = \omega(y_2, \eta_2)$  then  $y_2 = Gy_1 + \eta_1 = X(t_2, \omega_0)$ ,  $\eta_2 = R\eta_1$ ; in the general case for  $\omega_k = \omega(y_k, \eta_k)$  we get  $y_k = Gy_{k-1} + \eta_{k-1} = X(t_k, \omega_0)$ ,  $\eta_k = R\eta_{k-1}$ . By the Kolmogorov theorem on the set  $\Omega$  of DQM trajectories on  $\Lambda$  the probability measure  $\bar{\mu}$  was determined, induced there by a stationary state  $\mu$  on  $\Lambda$ . By construction measure  $\bar{\mu}$  inherit from measure  $\mu$  the invariance with respect to  $T$  ( $\bar{\mu}(T) = \bar{\mu}$ ) and ergodicity of  $T$  (i.e. its metric transitivity) under measure  $\bar{\mu}$ .

Let  $a(n, \omega) = D_n(\omega)$  for  $\omega = \omega(y_0, \eta)$ . Then  $a(n, \omega)$  are measurable functions on a probability space  $\Omega$  with measure  $\bar{\mu}$  and  $a(n+k, \omega) = a(k, T^k \omega)$ . This means that the square matrices  $a(n, \omega)$  of order  $m$  are a multiplicative cocycle on the space of trajectories  $\Omega$  with respect to its automorphism  $T$  by the definition of the cocycle [11]. Since  $G$  is a diffeomorphism, then  $\|DG(y)\| \neq 0$  for all  $y \in \Lambda$ , whence  $\ln(\|DG(y)\|)$  is continuous function on compact  $\Lambda$  and  $\int_{y \in \Lambda} \ln\|DG(y)\| d\mu < \infty$ . On the other hand by definition a measure for any open

subset  $C \subseteq \Lambda$  with the characteristic function  $\chi_C$

$$\int_{\Omega} \chi_C d\bar{\mu} = \bar{\mu}(\{\omega = (y, \eta) | y \in C\}) = \mu(\{y | y \in C\}) = \int_M \chi_C d\mu.$$

Therefore for any piecewise continuous function  $g$  on  $M$   $\int_{\Omega} g d\bar{\mu} = \int_M g d\mu$ . In

particular since  $a(0, \omega) = DG(y)$  on each trajectory  $\omega = \omega(y, \eta)$ , then

$$\int_{\omega \in \Omega} \ln\|a(0, \omega)\| d\bar{\mu} = \int_{y \in \Lambda} \ln\|DG(y)\| d\mu < \infty. \text{ This inequality means that the cocycle}$$

$a(n, \omega)$  is Lyapunov and this is the condition under which the multiplicative ergodic theorem for this cocycle holds.

This theorem asserts that almost all trajectories  $\omega \in \Omega$  under measure  $\bar{\mu}$  are Lyapunov correct. This means, in particular, that

1. for such  $\omega$  with  $u \in R^m$  ( $\|u\| = 1$ ) there are limits

$$\lim_{n \rightarrow \pm\infty} \frac{1}{n} \ln \|a(n, \omega)u\| = \pm\lambda_r(\omega),$$

where  $r = 1, 2, \dots, s = s(\omega) \leq m$ .

2. On each such trajectory  $\omega$ , the filtering of subspaces is uniquely defined:

$$\text{forward } L_1^+(y) \subset L_2^+(y) \subset \dots \subset L_s^+(y) = \mathbb{R}^m$$

$$\text{and back } L_s^-(y) \subset \dots \subset L_2^-(y) \subset L_1^-(y) = \mathbb{R}^m,$$

associated with the numbers  $\lambda_1 < \lambda_2 < \dots < \lambda_s$  ( $s = s(\omega)$ ) so that

$$\lim_{n \rightarrow \infty} \frac{1}{n} \ln \|a(n, \omega)u\| = \lambda_r \Leftrightarrow u \in L_r^+(y) \text{ and } u \notin L_{r-1}^+(y),$$

$$\lim_{n \rightarrow -\infty} \frac{1}{n} \ln \|a(n, \omega)u\| = -\lambda_r \Leftrightarrow u \in L_r^-(y) \text{ and } u \notin L_{r+1}^-(y).$$

These filtrations are invariant with respect to the automorphism  $T$ : if  $T\omega_n = \omega_{n+1}$ , then the cocycle  $a(n, \omega)$  takes the filtration  $\omega_n$  to the filtration  $\omega_{n+1}$ .

Since by the Kolmogorov theorem flow  $T$  on a probability space  $\Omega$  with a measure  $\bar{\mu}$  inherits ergodicity from ergodicity  $P$  on  $\Lambda$  with a measure  $\mu$ , which was established in Theorem 1. Then the values of  $\lambda_r(\omega) \equiv \lambda_r$ ,  $s(\omega) \equiv s$  coincide for almost all DQM trajectories  $\omega \in \Omega$  under measure  $\bar{\mu}$ . In view of the correspondence  $a(n, \omega) = D_n(\omega)$  the theorem immediately follows from here, QED.

By analogy with the theory of smooth dynamical systems the numbers  $\lambda_r$  we will call the Lyapunov characteristic exponents of the component  $\Lambda$  of the DQM attractor.

### 3 Structural Stability in DQM

**Definition 5.** The DQM realization is a sequence of smooth mappings  $G_k(y)$  on  $\Lambda$  in  $\Lambda \subseteq M$  ( $k = 0, \pm 1, \pm 2, \dots$ ) if  $\|G_k(y) - G(y)\|_{C^1} \leq d(y) \leq d$ , where  $d(y)$  are the constants from (3).

Here all the maps  $G_k(y)$  are diffeomorphisms on  $\Lambda$  in  $\Lambda$  for sufficiently small  $d$ . In terms of content  $\eta(t_k, y) = G_k(y) - G(y)$  are small random deviations caused by “white noise” at the point  $y$  at time  $t_k$ . By definition, any DQM trajectory  $\omega = \omega(y_0, \boldsymbol{\eta})$ :  $y_k = G y_{k-1} + \eta_k$  ( $k = 0, \pm 1, \pm 2, \dots$ ) is given by the initial point  $y_0 \in M$  and sequence of deviations  $\boldsymbol{\eta} = (\dots, \eta_{-k}, \dots, \eta_{-1}, \eta_0, \eta_1, \dots, \eta_k, \dots)$ . But on

the DQM realization the function of deviations  $\eta(t_k, y)$  is fixed; therefore, on it the DQM trajectory  $\omega$  with the initial point  $y_0$  is uniquely determined:  $\omega = \omega(y_0)$ .

**Definition 6.** A DQM realization  $G_k(y)$  ( $k = 0, \pm 1, \pm 2, \dots$ ) on a compact set  $K \subseteq \Lambda$  will be called a hyperbolic realization of DQM if at each point  $y \in K_k \subseteq \Lambda$ , where  $K_0 = K, G_k(K_{k-1}) = K_k$  there exists a decomposition of the tangent bundle  $TK_k$  into the Whitney sum of the subbundles  $E_k^s(y)$  and  $E_k^u(y)$ :  $TK_k = E_k^s(y) + E_k^u(y)$ , satisfying the following conditions:

1. the tangent map  $DG_k$  preserves the subbundles:

$$DG_k(E_k^s) \subseteq E_{k+1}^s, \quad DG_k(E_k^u) \subseteq E_{k+1}^u;$$

2.  $DG_k$  compresses  $E_k^s$ : on every trajectory  $\omega$  with an initial point  $y \in K_k$  at the time moment  $t_k$  there are such constants  $b > 0$  and  $\lambda$  ( $0 < \lambda < 1$ ) that for any  $u \in E_k^s$  and any natural  $n$

$$\|D_n(\omega)u\| \leq b\lambda^n \|u\| \quad (u \in E_k^s(y)).$$

3.  $DG_k$  stretches  $E_k^u(y)$ , more precisely, on each trajectory  $\omega$  with an initial point  $y \in K_k$  at the time moment  $t_k$  for any  $u \in E_k^u$  and a natural  $n$

$$\|D_n(\omega)u\| \geq \frac{1}{b\lambda^n} \|u\| \quad (u \in E_k^u(y)).$$

**Theorem 3.** Hyperbolic realizations are everywhere dense on the set of DQM realizations. More precisely, for any DQM realization  $G_k(y)$  ( $k = 0, \pm 1, \pm 2, \dots$ ) and for any sufficiently small  $\varepsilon > 0$  there exists such hyperbolic realization  $\widehat{G}_k(y)$  of this DQM on the compact  $K \subseteq \Lambda$ , that

1.  $\mu(\Lambda / K \cup K / \Lambda) < \varepsilon$  for the probabilistic invariant DQM measure  $\mu$  on  $\Lambda$ ;
2. on  $K_k$   $\|G_k(y) - \widehat{G}_k(y)\|_{C^1} < \varepsilon$  ( $k = 0, \pm 1, \pm 2, \dots$ ).

**Definition 7.** The realization of the DQM  $G_k(x)$  on a compact  $K \subseteq \Lambda$  and the realization  $\widetilde{G}_k(x)$  of this DQM on a compact  $\widetilde{K} \subseteq \Lambda$  are topologically equivalent if they are conjugate by means of homeomorphisms  $H_k$  defined on some neighborhoods

of the compacts  $K_k \subseteq \Lambda$ , where  $G_k(K_{k-1}) = K_k$ ,  $\tilde{G}_k(\tilde{K}_k) = \tilde{K}_{k+1}$ ,  $K_0 = K$ ,  $\tilde{K}_0 = \tilde{K}$ :  $\tilde{G}_k \circ H_k = H_{k+1} \circ G_k$  ( $k = 0, \pm 1, \pm 2, \dots$ ).

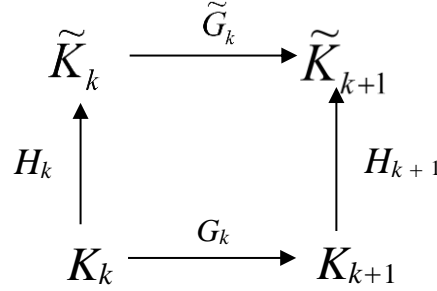


Fig. 1. Commutative diagram of topological equivalence.

**Definition 8.** A DQM realization  $G_k(x)$  on a compact  $K \subseteq \Lambda$  is structurally stable if any realization of this DQM sufficiently close to  $G_k(x)$  in  $C^1$  topology for all  $k = 0, \pm 1, \pm 2, \dots$  is topologically equivalent to it.

In more detail: If for every point  $x \in K_k$  there are numbers  $d_k(x) > 0$  such that for any realization of this DQM  $\tilde{G}_k(x)$  from  $\|G_k(x) - \tilde{G}_k(x)\|_{C^1} \leq d_k(x)$  for all  $k$  and  $x \in K_k$  the topological equivalence of the realizations  $G_k$  and  $\tilde{G}_k$  follows, then  $G_k$  is structurally stable.

If all  $G_k(x)$  and all compacts  $K_k$  coincide for all  $k$ , then we obtain the definition of the structural stability of a diffeomorphism.

**Theorem 4.** Any hyperbolic realization of the DQM  $G_k$  on the compact set  $K \subseteq \Lambda$  is structurally stable.

**Corollary 1.** A diffeomorphism  $G$  on a compact manifold  $M$  is structurally stable in the sense of Definition 8 if and only if it is (non-uniformly) hyperbolic.

**Proof.** Let a diffeomorphism  $G$  be structurally stable. By Definition 8, this means that for some  $d(x) \leq d = \varepsilon$  from  $\|G(x) - \tilde{G}(x)\|_{C^1} \leq d(x)$  ( $x \in M$ ) it follows that the diffeomorphisms  $G$  and  $\tilde{G}$  are topologically equivalent, that is, are conjugate on  $M$  by means of a homeomorphism. Consider DQM for  $G$  with the same  $d(x)$  in (3) for all  $x \in M$ . By Theorem 1, this DQM has an attractor, let  $\Lambda$  be a component of this attractor. By Theorem 3 there is a realization  $\tilde{G}_k(x)$  of this DQM, hyperbolic in the sense of Definition 6 on a compact set  $K$ , which differs from  $\Lambda$  only by the order  $d = \varepsilon$  on the measure  $\mu$  of the stationary state on  $\Lambda$ . Then by virtue of the

structural stability of  $G$  every diffeomorphism  $\tilde{G}_k$  of this realization is conjugate to  $G$  in a neighborhood of  $\Lambda$ . Therefore the realization with zero deviations, i.e. coinciding with  $G$  for each  $k$ , is also hyperbolic in  $\Lambda$  in the sense of Definition 6, and the component  $\Lambda$  itself is invariant with respect to  $G$  with accuracy  $\varepsilon$ . But then the complement  $M \setminus \Lambda$  is invariant with respect to  $G$  with accuracy  $\varepsilon$  too. Unless it turns out that with this accuracy  $M = \Lambda$ , then on  $M \setminus \Lambda$  we can similarly consider DQM for  $G$  with perhaps smaller than the earlier  $d(y) \leq \varepsilon$ . You can find there its component  $\Lambda_1$  and establish for realization  $\overline{G}_k$  with zero deviations hyperbolicity in neighborhood of in the sense of Definition 6  $\Lambda_1$  as we did it early; and so on. In general let  $\Delta$  be the greatest  $G$ -invariant with accuracy  $\varepsilon$  subset in  $M$ , in which the realization with zero deviations  $\overline{G}_k(x)$  is hyperbolic in the sense of Definition 6. If  $\Delta \neq M$  with accuracy  $\varepsilon$ , then on  $M \setminus \Delta$  as above we can obtain a new component, in which the realization with zero deviations  $\overline{G}_k$  is hyperbolic contrary to the assumption about  $\Delta$ . Tending  $\varepsilon$  to zero, we obtain the hyperbolicity of the realization  $\overline{G}_k$  with zero deviations at almost all points  $x \in M$ . In this case, generally speaking, we have  $\inf d(x) = 0$ . This means the non-uniform hyperbolicity of the diffeomorphism  $G$  onto  $M$ .

Conversely, the fact that the non-uniform hyperbolicity of a diffeomorphism  $G$  onto  $M$  implies its structural stability in the sense of Definition 8 directly follows from Theorem 4, QED.

**Corollary 2.** If for some  $\varepsilon > 0$  from  $\|G(x) - \tilde{G}(x)\|_{C^1} \leq \varepsilon$  ( $x \in M$ ) follows that diffeomorphisms  $G$  and  $\tilde{G}$  are topologically equivalent, then  $G$  is (uniformly) hyperbolic diffeomorphism on  $M$ .

**Proof.** It follows from Corollary 1 that  $G$  is hyperbolic, in general, non-uniform. If  $G$  is hyperbolic exactly non-uniformly and so  $\inf d(y) = 0$  for  $d(y)$  from definition 8, then we can get some diffeomorphism  $\tilde{G}$  inequivalent to  $G$  with arbitrarily small perturbations. However from  $\|G(x) - \tilde{G}(x)\|_{C^1} \leq \varepsilon$  ( $x \in M$ ) follows that  $G$  and  $\tilde{G}$  are topologically equivalent by the condition of the corollary. Therefore  $G$  is uniformly hyperbolic on  $M$ , QED.



#### 4 Example of DQM Application: Henon System Attractor

For the two-dimensional M. Henon system [10]:  $(x, y) \rightarrow (1 + y - ax^2, bx)$  values of parameters  $a = 1.7, b = 0.5$  are chosen such that the hyperbolicity of dynamics on the attractor with this parameters is rigorously proved for R. Lozi system [14]  $(x, y) \rightarrow (1 + y - a|x|, bx)$ . The proof of the hyperbolic dynamics here is based on the following statement, specifically focused on the study of concrete dynamical systems. For ease of application to the Henon system in the formulation we restrict ourselves to the two-dimensional case, although the multidimensional generalization is also true.

**Corollary 3.** Let  $\Delta_i$  be the cells of  $\varepsilon$ -discretization of the DQM attractor for the system given by the diffeomorphism  $G$ ,  $x_i \in \Delta_i$  ( $1 \leq i \leq N$ ). Let the eigenvalues  $\lambda_1(x_i)$  and  $\lambda_2(x_i)$  of the differential  $DG$  at each point  $x_i \in \Delta_i$  ( $1 \leq i \leq N$ ) satisfy the conditions  $\lambda_1(x_i) < \mu$ ,  $\lambda_2(x_i) > \frac{1}{\mu}$  for some  $\mu$  ( $0 < \mu < 1$ ) and

$$\varepsilon \leq \frac{(1 - \mu)^2}{4(4\|G\|_2 + 1)}, \quad (6)$$

where  $\|G\|_2$  is the norm of  $G$  in  $C^2$ . Then

1. the initial system given by the diffeomorphism  $G$  is hyperbolic on its attractor;
2. any DQM  $\varepsilon$ -realization of this system is hyperbolic on the DQM attractor and is topologically equivalent to the initial system;
3. the support of the attractor of the initial hyperbolic system and the attractor of its DQM  $\varepsilon$ -realization coincide with an accuracy of order  $\varepsilon$ .

The proof of this statement essentially reproduces the proof of Theorem 4, estimate (6) is actually obtained there. The verification of the conditions of Corollary 3 for the Henon system uses 4 *Maple* procedures.

1. The *Animate* procedure visualizes system behavior using animation technologies in *Maple*. This allows you to localize the region of the phase space in which the system attractor is hypothetically contained. In the graph of next fig.2 for each iteration  $t$  shows the point in phase space of Henon system.

On the basis of outcomes of the numerical researches, visually presented in Figure 2, we choose a rectangle  $\Omega = \{(x, y) \mid -1 \leq x \leq 1.5; -0.1 \leq y \leq 0.1\}$ . In next Figure 3 for each iteration  $t = 1, 2, \dots, 500$  of Henon system corresponds its coordinate  $x(t)$  on the ordinate axis.

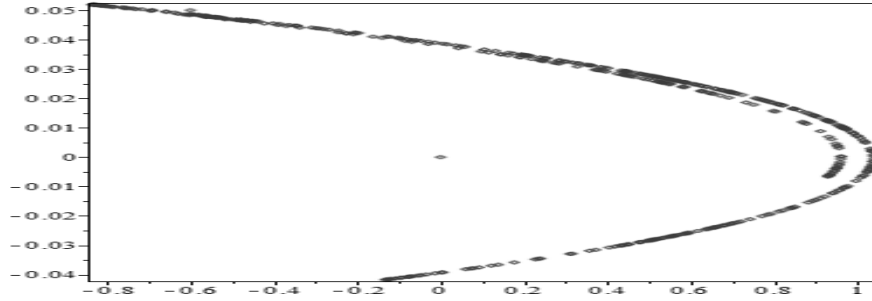


Fig. 2. Phase curve of Henon system.

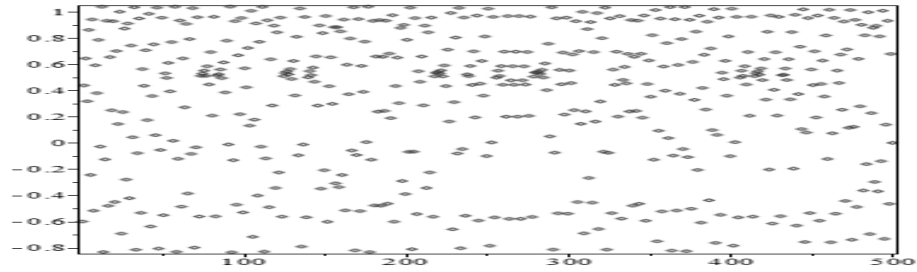


Fig. 3. Trajectory of Henon system.

The animation in Figure 3 suggests that the system is hyperbolic.

2. The *Prestep* procedure splits the rectangle  $\Omega$  into cells  $\Delta_i$  - squares with sides of length 0.01 parallel to the axes of coordinates ( $1 \leq i \leq N$ ). Then each cell  $\Delta_i$  *Prestep* associates a set of cells into which points from  $\Delta_i$  can fall into one step of the dynamics of the Henon system. In this case it is formally verified that the domain  $\Omega$  is indeed invariant with respect to the discretization of the DQM, given by the constructed partition of  $\Omega$ . In other words *Prestep* defines a topological Markov chain  $H$ , the state space of which is the set of cells  $\Delta_i \subset \Omega$ .
3. The *Findattr* procedure finds in  $\Omega$  the attractor of a topological Markov chain  $H$  defined in *Prestep*. Its algorithm is based on the following consideration. On the state space  $\Omega = \{\Delta_i\}$  consider a transitive quasi-order relation:  $\Delta_i \prec \Delta_j$  if there exists a trajectory  $H$  from  $\Delta_i$  to  $\Delta_j$ . The state  $\Delta_i$  is recurrent if  $\Delta_i \prec \Delta_i$ . Recurrent states are divided into equivalence classes:  $\Delta_i \sim \Delta_j \Leftrightarrow \Delta_i \prec \Delta_j \prec \Delta_i$ . On  $\Omega = \{\Delta_i\}$   $H(\Omega) \supseteq H^2(\Omega) \supseteq H^3(\Omega) \supseteq \dots \supseteq H^n(\Omega)$ . If  $H^n(\Omega) = H^{n+1}(\Omega)$  then  $H^n(\Omega)$  is the DQM attractor. In the case under consideration, the attractor turns out to be connected, which corresponds to Fig. 2, obtained by the *Animate* procedure.

4. The *Hyperproc* procedure performs a main check: do the conditions of Corollary 3 be satisfied on the attractor found by *Findattr*? For the Henon system under consideration on a rectangle  $\Omega = \{(x, y) | -1 \leq x \leq 1.5; -0.1 \leq y \leq 0.1\}$  we obtain  $\|G\|_2 = \max_{\Omega} \{\sqrt{(2ax)^2 + b^2} + 1, 2a\} \approx 6.1$ . The *Hyperproc* procedure establishes that for the differential  $DG$  eigenvalues  $\lambda_1(x_i) < 0.4$  and  $\lambda_2(x_i) > 1.7$  for all  $x_i \in \Delta_i$ . The value  $1/1.7 \approx 0.59$ . Thus  $\mu \geq 0.59$ ; however, we choose the value  $\mu = 0.7$  with a margin. Then, in accordance with (6), it is necessary that  $\varepsilon \leq 0.00089$ .

Now the cell length of  $\Delta_i$  (the length of a square with sides parallel to the axes of coordinates) is chosen equal to 0.0005 ( $1 \leq i \leq N$ ) and already for such a small partition of the rectangle  $\Omega$  we repeat the *Prestep*  $\rightarrow$  *Findattr*  $\rightarrow$  *Hyperproc* cycle described above. Now the other smaller cells are  $\Delta_i$ , the other  $x_i \in \Delta_i$  and the other eigenvalues  $\lambda_1(x_i)$  and  $\lambda_2(x_i)$  respectively ( $1 \leq i \leq N$ ). If now again  $\lambda_1(x_i) < 0.4$  and  $\lambda_2(x_i) > 1.7$  holds for all  $i$ , then (6) holds for such a partition and therefore Corollary 3 holds. In our case, the test was successful, which proves the hyperbolicity of the dynamics on the attractor of the Henon system for the values of the parameters  $a = 1.7$ ,  $b = 0.5$ . As a result, the structure of a topological Markov chain obtained in the course of computer calculations, by virtue of 2) and 3) of Corollary 3, gives detailed and rigorously proved data on the dynamics of this system.

The selected values of the parameters  $a = 1.7$ ,  $b = 0.5$  are not the only ones. For example, similar results are obtained for  $a = 1.4$ ,  $b = 0.35$ .

## 5 Conclusion

The structural stability of a mathematical model is a necessary condition for its correctness. It is also necessary for applicability of numerical methods, computational experiments since they inevitably lead to errors.

But after S. Smale's works it became clear that in smooth dynamics the system of a general form is not structurally stable and therefore there is no strict mathematical basis for modeling and computational analysis of systems. The contradiction appeared in science: according to physicists dynamics is simple and universal.

The paper proposes a solution to this problem based on the construction of dynamic quantum models (DQM). DQM is a perturbation of a smooth dynamical system by a Markov cascade (time is discrete). The dynamics obtained in this way are simpler than the classical smooth dynamics: the structurally stable realizations of DQM are everywhere dense (Theorem 3) and open (Theorem 4) on the set of all DQM realizations. This dynamics has a clear structural theory: unlike the classical systems, the DQM attractor is uniquely defined (Theorem 1), Lyapunov exponents exist for any DQM (Theorem 2).

As a Markov cascade, the DQM is approximated by a Markov chain and on a compact set by a finite Markov chain arbitrarily exactly (Theorem 1). This allows you to clearly understand the DQM dynamics and build effective algorithms for the study of concrete systems that are always oriented towards parallel computing and do not require stable (according to Hadamard) solutions. For example, in part 4 we demonstrate the use of computer simulation for rigorous proof of hyperbolicity of the attractor of Henon system.

On the other hand, when fluctuations tend to zero, i.e. in the semiclassical limit, the dynamics of the DQM goes into the initial smooth dynamics. In part 3 the equivalence of structural stability and hyperbolicity for smooth discrete dynamical systems is established along this path (Corollaries 1 and 2).

In the future, we intend to apply the DQM algorithms, that oriented towards parallel computing and do not require stable solutions, to traditional problems of computational methods.

We also intend to generalize dynamic quantum models on dynamical systems that using logical operations: proofs of theorems, software applications, information and network systems, etc. A natural and even obvious implementation tools for such a generalization are the specialized neural network. This will allow the use of DQM methods for problems of artificial intelligence: identification, prediction, filtering, etc.

## References

1. Morrison, M. Models, measurement and computer simulation: the changing face of experimentation. *Philosophical Studies*, 143, 33–57 (2012).
2. G. Dubois, Taylor, Francis (2018). *Modeling and Simulation*. CRC Press.
3. Peschard, I. Modeling and Experimenting. In: P. Humphreys and C. Imbert (eds), *Models, Simulations, and Representations*. pp. 42–61 London: Routledge (2010).
4. Yang, X. S. (2008). *Introduction to Computational Mathematics*. World Scientific.
5. V. I. Arnold (1982). *Mathematical methods of classical mechanics*. Springer-Verlag.
6. Teschl, Gerald (2012). *Ordinary Differential Equations and Dynamical Systems*. Providence: American Mathematical Society.
7. Smale S. (1966) Structurally stable systems are not dense. *Am. J. Math.*, 88, P. 491 – 496.
8. Tesse E. (2011) *Principals of Dynamic Systems and the Foundations of Quantum Physics*. SIAM.
9. Weissblut A. (2011) Non-Hamiltonian Quantum Mechanics and the Numerical Researches of the Attractor of a Dynamical System. *Informational Technologies in Education* 11 P. 73 – 78
10. Henon M. (1976) A two – dimensional mappings with a strange attractor. *Commun. Math. Phys.* 50, N 1, P. 69 – 77
11. David D. Nolte (2015). *Introduction to Modern Dynamics: Chaos, Networks, Space and Time*. Oxford University Press.
12. Katok A., Hasselblatt B. (1996). *Introduction to the modern theory of dynamical systems*. Cambridge
13. David Stirzaker (2005). *Stochastic Processes and Models*. Oxford University Press.
14. Lozi R. (1978) Un attracteur etrange du type attracteur de Henon. *J. Phis. Col.*, 39, P. 9 – 10

# Event Universes: Specification and Analysis Using Coq Proof Assistant

Grygoriy Zholtkevych<sup>[0000-0002-7515-2143]</sup>

School of Mathematics and Computer Science  
V.N. Karazin Kharkiv national University,  
4, Svobody Sqr., Kharkiv, 61022, Ukraine  
[g.zholtkevych@karazin.ua](mailto:g.zholtkevych@karazin.ua)

**Abstract.** In the paper, the formal specification of event universes theory developed with using Coq Proof Assistant is presented. The main attention is paid on the discussion of the definition and obtained facts. In the same time, a proof technique is not the subject of this discussion. The reader can get acquainted with the details of the proof technique, referring to the source text of Coq-scripts hosted on the GitHub, using the links provided in the text of the paper.

**Keywords:** causality relationship· Calculus of Inductive Constructions· Coq Proof Assistant· decidability· class type· Category Theory

## 1 Introduction

Inception of distributed computation technology has posed a problem of orchestration of different computational device operating. One of the key problem in this context is to ensure adequate responses of a computational device involved into the computation to requests of other computational devices involved into the computation too in order to ensure all these computational devices behave consistently and purposefully. Thus, it is needed to give system developers tools for specification and analysis of timing constraints for ensuring the consistent behaviours of hardware and software constituted the system being under design. Hence, we may claim that carefully vetted specification guaranteeing the system behaviour consistency in the time is the important part of a good design for a distributed system.

The specificity of the design process for distributed systems is the impossibility to apply the methods of dynamic analysis of program code to ensure its correctness. The reason for the validity of this claim is that any additional observations of the system are not possible without inclusion into the system special components, which collect the needed information but at the same time these components change the system behaviour. In some sense, we have behaviour like quantum behaviour: any observation changes essentially the system behaviour. In the situation when dynamical analysis of the system correctness is not useful, the static analysis remains the unique method for assessment of system behaviour correctness. Thus, the creation of a rigorous theory, which

would ensure computer aided in developing special software for verification and analysis of causality specifications for distributed systems is a very important problem for nowadays.

To solve the problem we propose to use Coq Proof Assistant [1] and for constructing the corresponding formal theory. Informally, we use as the theoretical framework for our construction the following papers, which had initiated and developed a number of logical time models. First of all, this is L. Lamport's paper [2]. Further, we need to mention G. Winskel's papers [3]. We use also as informal background papers of C. André and F. Mallet [4,5,6]. Own results presented in [7,8] are also used.

## 2 Preliminaries: Binary Relations

Theory of binary relations form a mathematical basis for studying causality relationship. Therefore, we present the Coq-specification<sup>1</sup> used below for the some needed for us fragment of the binary relation theory in this section.

We stress that we assume the some variant of the extensionality formalised as the axiom called `extensionality`.

`Axiom extensionality :`

$$\forall (A B : \text{Type}) (f g : A \rightarrow B), (\forall x : A, f x = g x) \rightarrow f = g.$$

The next code section defines binary relations and their properties.

`Section EventPreliminaries.`

`Variable U : Type.`

`Definition BiRel : Type := U → U → Prop.`

`Definition Reflexive (R : BiRel) : Prop :=  $\forall x : U, R x x$ .`

`Definition Irreflexive (R : BiRel) : Prop :=  $\forall x : U, \neg R x x$ .`

`Definition Symmetric (R : BiRel) : Prop :=  $\forall x y : U, R x y \rightarrow R y x$ .`

`Definition Transitive (R : BiRel) : Prop :=`

$$\forall x y z : U, R x y \rightarrow R y z \rightarrow R x z.$$

`Inductive Preorder (R : BiRel) : Prop :=`

$$\text{PreorderDef} : \text{Reflexive } R \rightarrow \text{Transitive } R \rightarrow \text{Preorder } R.$$

`Inductive Equivalence (R : BiRel) : Prop :=`

`EquivalenceDef :`

$$\text{Reflexive } R \rightarrow \text{Transitive } R \rightarrow \text{Symmetric } R \rightarrow \text{Equivalence } R.$$

`Inductive StrictOrder (R : BiRel) : Prop :=`

$$\text{StrictOrderDef} : \text{Irreflexive } R \rightarrow \text{Transitive } R \rightarrow \text{StrictOrder } R.$$

`Definition Decidable (R : BiRel) : Prop :=`

$$\forall x y : U, R x y \vee \neg R x y.$$

`End EventPreliminaries.`

<sup>1</sup> This specification is contained in <https://github.com/gzholtkevych/Causality/blob/master/Coq/EventPreliminaries.v>.

Further, we give definitions for the polymorphic identity function and composition of functions.

**Definition** `id`  $\{A : \text{Type}\} := \text{fun } x : A \Rightarrow x$ .

**Definition** `compose`  $\{A B C : \text{Type}\} (f : A \rightarrow B) (g : B \rightarrow C) : A \rightarrow C :=$   
`fun x : A => g (f x)`.

**Notation** `"g * f"`  $:= (\text{compose } f \text{ } g)$   
(at level 40, `left` associativity) : `event_scope`.

Now we prove the following propositions.

**Proposition 1** (`id_is_leftId`).

*For any sets  $A$  and  $B$  and function  $f : A \rightarrow B$ , the equation  $\text{id}_B f = f$  holds.*

**Proposition 2** (`id_is_rightId`).

*For any sets  $A$  and  $B$  and function  $f : A \rightarrow B$ , the equation  $f \text{id}_A = f$  holds.*

**Proposition 3** (`compose_is_assoc`).

*For any sets  $A, B, C$ , and  $D$  and functions  $f : A \rightarrow B, g : B \rightarrow C$ , and  $h : C \rightarrow D$ , the equation  $(h.g) f = h(g.f)$  holds.*

We need also the following concept

**Definition** `Decidable`  $(R : \text{BiRel}) : \text{Prop} := \forall x y : U, R x y \vee \neg R x y$ .

**End** `EventPreliminaries`.

### 3 Event Universes

This section introduces in the logical time model that focuses on the causality relationships between event occurrences called instants below.

#### 3.1 Informal Meaning and Mathematical Definitions

The principal causality relationship between events  $A$  and  $B$  is labelled by the sentence “the event  $A$  causes the event  $B$ ”. We consider informally that the semantic meaning this sentence is the statement “if the event  $A$  has not occurred then the event  $B$  cannot occur” rather than the statement “if the event  $A$  has occurred then the event  $B$  should also occur”. It is evident that this semantic meaning leads to the following properties of the causality relationship

1. each event causes itself;
2. if an event  $A$  causes an event  $B$  and the event  $B$  causes an event  $C$  then the event  $A$  causes the event  $C$ .

Thus, we can accept the following definition of an event universe.

**Definition 1.** A set  $U$  equipped with a preorder (quasi-order) relation “ $\ll$ ” is below called an event universe.

The statement “ $x \ll y$ ” where  $x, y \in U$  is pronounced as “ $x$  causes  $y$ ”.

It is well known that each preorder generates an equivalence and a strict order, which are below called synchronisation and precedence and denoted by “ $\doteq$ ” and “ $<$ ” respectively. The definitions of these relations are the following

**Definition 2.** Let a set  $U$  equipped with a preorder “ $\ll$ ” be an event universe then

1. the relation  $x \doteq y$  between any  $x, y \in U$  (pronounced  $x$  and  $y$  are synchronous) is defined by the condition  $x \ll y$  and  $y \ll x$  and called the synchronisation relation;
2. the relation  $x < y$  between any  $x, y \in U$  (pronounced  $x$  precedes  $y$ ) is defined by the condition  $x \ll y$  and  $\neg y \ll x$  and called the precedence relation.

Moreover, the next two relations called mutual exclusion and independence are useful too.

**Definition 3.** Let a set  $U$  equipped with a preorder “ $\ll$ ” be an event universe then

1. the relation  $x \# y$  between any  $x, y \in U$  (pronounced  $x$  and  $y$  are mutually exclusive) is defined by the condition  $x < y$  or  $y < x$  and called the mutual exclusive relation;
2. the relation  $x \parallel y$  between any  $x, y \in U$  (pronounced  $x$  and  $y$  are independent) is defined by the condition  $\neg x \ll y$  and  $\neg y \ll x$  and called the independence relation.

### 3.2 Formal Model of an Event Universe and Used Notation

Now we are ready to specify the formal model of the concept of an event universe using Coq Proof Assistant. We consider the type classes [9,10] as the appropriate construction of the Gallina specification language to describe the required model. More details, one can find in the following fragment of Coq-script<sup>2</sup>.

The concept of an event universe introduces as follows

```
Class Event {A : Type} :=
  { universe := A ;
    causality : BiRel universe ;
    (* Constraints *)
    causality_constraint (* causality is a preorder *) :
      Preorder universe causality ;
    (* Derived relations *)
    synchronisation : BiRel universe :=
      fun x y => causality x y & causality y x ;
```

<sup>2</sup> The complete code is contained in <https://github.com/gzholtkevych/Causality/blob/master/Coq/EventDefinitions.v>



```

precedence : BiRel universe :=
  fun x y => causality x y ∧ ¬ causality y x ;
exclusion : BiRel universe :=
  fun x y => precedence x y ∨ precedence y x ;
independence : BiRel universe :=
  fun x y => ¬ causality x y ∧ ¬ causality y x
}.

```

This script specifies an event universe as some type called `universe` equipped with a binary relations `causality`. The script imposes only one constraint, namely, the relation `causality` should be a preorder. The class definition determines also the derived relations `synchronisation`, `precedence`, `exclusion`, and `independence` in accordance with Def. 2 and 3.

In order for scripts specifying the formal theory being developed and giving proofs of the facts are more compact and readable, the following notation is introduced.

```

Notation "x << y" (* x causes y *) := (causality x y)
  (at level 70) : event_scope.
Notation "x ≐ y" (* x and y are synchronous *) := (synchronisation x y)
  (at level 70) : event_scope.
Notation "x < y" (* x precedes y *) :=
  (precedence x y) (at level 70) : event_scope.
Notation "x # y" (* x and y are mutually exclusive *) := (exclusion x y)
  (at level 70) : event_scope.
Notation "x || y" (* x and y are independent *) := (independence x y)
  (at level 70) : event_scope.

```

## 4 Properties of an Event Universe

In this section, we establish several properties of the relations mentioned in the specification of the type class `Event`. In this section, we present several simple properties of the relations mentioned in the specification of type class `Event`. Our presentations are the formulations of the properties as mathematical statements. Each such a statement is equipped with the reference to the corresponding CIC-term [11], which one can find in <https://github.com/gzholtkevych/Causality/blob/master/Coq/EventRelationFacts.v>.

Everywhere in this section, we assume that  $U$  is an event universe equipped with the causality relation “ $\ll$ ” and the synchronisation relation “ $\doteq$ ”, precedence relation “ $<$ ”, mutual exclusion relation “ $\#$ ”, and independence relation “ $\parallel$ ” are defined by Def. 2 and Def. 3.

### 4.1 Simple Properties of Relations

Firstly, we establish the properties of the synchronisation relation.

**Proposition 4** (`synchronisation_implies_causality`).

*For any events  $x$  and  $y$ ,  $x \doteq y$  implies  $x \ll y$ .*

**Lemma 1** (`synchronisation_is_reflexive`).  
*The synchronisation relation is reflexive.*

**Lemma 2** (`synchronisation_is_transitive`).  
*The synchronisation relation is transitive.*

**Lemma 3** (`synchronisation_is_symmetric`).  
*The synchronisation relation is symmetric.*

These lemmas ensure immediately the following proposition.

**Proposition 5** (`synchronisation_is_equivalence`).  
*The synchronisation relation is an equivalence.*

Further, we establish properties of the precedence relation.

**Proposition 6** (`precedence_implies_causality`).  
*For any events  $x$  and  $y$ ,  $x < y$  implies  $x \ll y$ .*

**Lemma 4** (`precedence_is_irreflexive`).  
*The precedence relation is irreflexive.*

**Lemma 5** (`precedence_is_transitive`).  
*The precedence relation is transitive.*

These lemmas ensure immediately the following proposition.

**Proposition 7** (`precedence_is_strictOrder`).  
*The precedence relation is a strict order.*

Now we establish properties of the mutual exclusion relation.

**Proposition 8** (`exclusion_is_irreflexive`).  
*The mutual exclusion relation is irreflexive.*

**Proposition 9** (`exclusion_is_symmetric`).  
*The mutual exclusion relation is symmetric.*

The independence relation has the same properties.

**Proposition 10** (`independence_is_irreflexive`).  
*The independence relation is irreflexive.*

**Proposition 11** (`independence_is_symmetric`).  
*The independence relation is symmetric.*

## 4.2 Relations Incompatibility

The next group of facts concerns the incompatibility of the relations being studied.

**Proposition 12** (`incompatibility_of_synchronisation_and_exclusion`).

*For any events  $x$  and  $y$ , at most one of the statements  $x \dot{\div} y$  and  $x \# y$  is fulfilled.*

**Proposition 13** (`incompatibility_of_synchronisation_and_independence`).

*For any events  $x$  and  $y$ , at most one of the statements  $x \dot{\div} y$  and  $x \parallel y$  is fulfilled.*

**Proposition 14** (`incompatibility_of_exclusion_and_independence`).

*For any events  $x$  and  $y$ , at most one of the statements  $x \# y$  and  $x \parallel y$  is fulfilled.*

One can note that the mutual exclusion relation between events  $x$  and  $y$  ensures either  $x < y$  or  $y < x$  but does not determine what of these precedence statements is fulfilled. To determine what precedence statement is valid one can use the following fact.

**Proposition 15** (`causality_distinguishes_exclusion`).

*For any events  $x$  and  $y$  such that  $x \# y$ ,  $x \ll y$  implies  $x < y$ .*

Further reasoning is aimed at identifying conditions that ensure the fulfillment of the following statement called `ixsDecomposition` that means the following

$$\text{for any events } x \text{ and } y, x \parallel y \vee x \# y \vee x \dot{\div} y.$$

The next theorem formulates the obtained result.

**Theorem 1** (`decidable_causality_is_equivalent_to_ixsDecomposition`).

*`ixsDecomposition` is fulfilled if and only if the causality relation is decidable.*

## 4.3 Congruence Properties

In this subsection, we establish interrelations between the synchronisation relation and other relations being studied. The corresponding scripts proving these facts one can find at <https://github.com/gzholtkevych/Causality/blob/master/Coq/EventSynchronisationCongruenceProperties.v>.

**Proposition 16** (`congruence_causality`). *For any events  $x, x'$  and  $y, y'$  such that  $x \dot{\div} x'$  and  $y \dot{\div} y'$ ,  $x \ll y$  implies  $x' \ll y'$ .*

**Proposition 17** (`congruence_precedence`). *For any events  $x, x'$  and  $y, y'$  such that  $x \dot{\div} x'$  and  $y \dot{\div} y'$ ,  $x < y$  implies  $x' < y'$ .*

**Proposition 18** (`congruence_exclusion`). *For any events  $x, x'$  and  $y, y'$  such that  $x \dot{\div} x'$  and  $y \dot{\div} y'$ ,  $x \# y$  implies  $x' \# y'$ .*

**Proposition 19** (`congruence_independence`). *For any events  $x, x'$  and  $y, y'$  such that  $x \dot{\div} x'$  and  $y \dot{\div} y'$ ,  $x \parallel y$  implies  $x' \parallel y'$ .*

Summing up the above we can state that the synchronisation relation is a congruence for all other considered relations.

## 5 Morphisms of Event Universes

In this section, we beat a path to using Category Theory<sup>3</sup> for studying causality in distributed systems. The concept of morphism is the key to such consideration. The specification of type class presented below `EventMorphism` can be found at <https://github.com/gzholtkevych/Causality/blob/master/Coq/EventDefinitions.v>.

```
Class EventMorphism {A B : Type} '{Event A} '{Event B} (f : A → B) :=
{
  arrow := f ;
  (* Constraints *)
  preserving_sync : ∀ x y : A, x ≐ y → arrow x ≐ arrow y ;
  preserving_precedence : ∀ x y : A, x < y → arrow x < arrow y
}.
```

In other words, an event morphism is a mapping of corresponding event sets that preserves the synchronisation and precedence relations.

The proving scenarios for the facts presented above one can find at <https://github.com/gzholtkevych/Causality/blob/master/Coq/EventMorphisms.v>

First of all, we establish that morphism preserves all relations, except perhaps independence relations.

**Proposition 20** (`preserving_sync`).

*For any event universes  $A$  and  $B$ , morphism  $f : A \rightarrow B$ , and events  $x$  and  $y$  of  $A$  such that  $x \doteq y$ , the statement  $fx \doteq fy$  is fulfilled.*

**Proposition 21** (`preserving_prec`).

*For any event universes  $A$  and  $B$ , morphism  $f : A \rightarrow B$ , and events  $x$  and  $y$  of  $A$  such that  $x < y$ , the statement  $fx < fy$  is fulfilled.*

Now we check that identity mapping is a morphism.

**Proposition 22** (`id_is_morphism`).

*For any event universe  $A$ ,  $id_A$  is a morphism.*

Let us make sure that the composition of morphisms is a morphism.

**Proposition 23** (`composition_of_morphisms_is_morphism`).

*For any event universes  $A$ ,  $B$ , and  $C$  and morphisms  $f : A \rightarrow B$  and  $g : B \rightarrow C$ ,  $gf$  is a morphism.*

Combining Prop. 22 and 23 with Prop. 1–3 one can obtain the following theorem.

**Theorem 2.** *The class of event universes equipped with morphisms is a category.*

Category-theoretic studying causality relationships was initiated in the papers [7,8].

---

<sup>3</sup> See, for example, [12]

## 6 Conclusion

This paper presents the formal approach to study causality relationships in distributed systems.

In the paper, the basic formal theory developed with Coq Proof Assistant has been described.

Further research and development may be focused on

- the formalisation with Coq Proof Assistant of finiteness conditions to emphasise the subclass of discrete event universes;
- the identification of states related to events to try to construct a natural coalgebra for specifying the behaviour of systems being studied;
- the identification of logical clocks for obtaining some complete and usable causality constraint specification language.

## References

1. Bertot, Y., Castéran, P.: *Interactive Theorem Proving and Program Development*. Springer-Verlag Berlin Heidelberg (2004)
2. Lamport, L.: Time, clocks, and the ordering of events in a distributed system. *Communications of the ACM* 21(7), 558–565 (1978)
3. Winskel, G.: Event structures. In: Brauer, W., Reisig, W., Rozenberg, G. (eds.) *Petri Nets: Applications and Relationships to Other Models of Concurrency*. LNCS, vol. 255, pp. 325–392 (1986)
4. André, C., Mallet, F.: UML/MARTE CCSL, Signal and Petri nets. Research Report RR-6545, INRIA (2008)
5. André, C., Mallet, F., De Simone, R.: Logical time: specification vs. implementation. *ACM SIGSOFT Software Engineering Notes* 36(1), 1–8 (2011)
6. Mallet, F.: MARTE/CCSL for modeling cyber-physical systems. In: Drechsler, R., Kühne, U. (eds.) *Formal Modeling and Verification of Cyber-Physical Systems*. Springer Vieweg, Wiesbaden (2015)
7. Zholtkevych, G., El Zein, H.: Two Approaches to Modelling Logical Time in Cyber-Physical Systems. In: Basliades, N., et al. (eds.) *ICT in Education, Research, and Industrial Applications*, CCIS, vol. 826, pp. 21–40. Springer International Publishing AG (2018)
8. Zholtkevych, G., El Zein, H., Polyakova, L.: Category Methods for Modelling Logical Time Based on the Concept of Clocks. In: Ermolayev, V., et al. (eds.) *ICT in Education, Research, and Industrial Applications*, CCIS, vol. 1007, pp. 89–101. Springer International Publishing AG (2019)
9. The Coq Development Team: Type Classes. In: *The Coq Reference Manual*. INRIA, 8.9.0 edn. (2019), <https://coq.inria.fr/distrib/current/refman/index.html>, (accessed 2.02.2019)
10. Lampropoulos, L., Pierce, P.C.: QuickChick: Property-Based Testing in Coq, *Software Foundations*, vol. 4 (2018), <https://softwarefoundations.cis.upenn.edu/qc-current/index.html>, (accessed 2.02.2019)
11. The Coq Development Team: The Gallina specification language. In: *The Coq Reference Manual*. INRIA, 8.9.0 edn. (2019), <https://coq.inria.fr/distrib/current/refman/index.html>, (accessed 2.02.2019)
12. Awodey, S.: *Category Theory*, *Oxford Logic Guides*, vol. 52. Oxford University Press, 2nd edn. (2010)

# Formalization and Algebraic Modeling of Tokenomics Projects

Oleksandr Letychevskyi<sup>1</sup>[0000-0003-0856-9771], Volodymyr Peschanenko<sup>1</sup>[0000-0003-1013-9877],  
Viktor Radchenko<sup>1</sup>[0000-0003-4218-5376], Maksym Poltoratskyi<sup>2</sup>[0000-0001-9861-4438]  
and Yuliia Tarasich<sup>2</sup>[0000-0002-6201-4569]

<sup>1</sup>Garuda AI V.B., Het Poortgebouw, Beech Avenue 54-62, Schiphol, 1119 PW, Netherlands  
<sup>2</sup>Kherson State University, Universytets'ka St. 27, 73000, Kherson, Ukraine

{oleksandr.letychevskyi, volodymyr.peschanenko, viktor.radchenko}@garuda.ai, {mpoltorackiy, YuTarasich}@gmail.com

**Abstract.** This article provides a brief description of the technology and the methods and tools developed by the authors for token economy modeling and for the analysis and study of its properties. The article also describes the formalization of the tokenomics model on the example of the SKILLONOMY project and presents the specific and symbolic SKILLONOMY models and its simulation results.

**Keywords:** tokenomic modeling, blockchain, tokenomics, crypto-economics, symbolic modeling, insertion modeling.

## Introduction

The development of blockchain technologies has led to the development of a new direction in the economy, referred to as crypto-economics or “tokenomics”. Developing an effective tokenomics model is key to the long-term life of the blockchain project. Thus, it is important to understand and to analyze the effectiveness of a crypto-economy model.

There are many approaches to check the crypto-economy models, including games theory, probability and modeling approaches.

A review of the current state of information about the approaches, methods and tools for analyzing and simulating crypto-economic shows that the question of the right approach is still a real open question, with concerns about open access to a wide audience. The largest number of authors use the agent modeling as a tool for analysis. In [1], approaches for analyzing various crypto-economics are described. The author solves the problem associated with the modeling of microtokenomics using agent-based modeling. To optimize the analysis using agent-based modeling, the author also uses machine learning methods and genetic algorithms. In [2], the economic system as a discrete finite automaton is considered. The principle of simulation is based on the following methods: deterministic stochastic processes, stochastic processes and

the Monte Carlo Simulation. Some examples of visualization and simulation modeling were also described in [3] and evaluated in [4]. Thus, we can conclude that there is still a relevant need for tokenomics models that can verify and simulate and that new solutions are required. The authors of this article proposes using methods of algebraic programming and insertion modeling [5] for verification and simulation of crypto-economics models using the example of the SKILLONOMY project [6].

In the first section of this article, a brief description of the proposed methods and tools is given. The second section of this article describes the formalization of the tokenomics model in the SKILLONOMY project. In the third and fourth sections, the specific and symbolic SKILLONOMY models and their simulation results are described.

## 1 Our contribution

We propose an algebraic approach to tokenomic modeling that is implemented in the scope of the insertion modeling system (IMS) [5]. Insertion modeling focuses on building models and studying the interaction of agents and environments in complex distributed multi-agent systems [5,7].

With regard to mathematical refinements, we chose a transition system for the agent that is the most abstract mathematical concept, modeling a system that evolves over time. This approach is used for the formalization stage and the verification stage of the properties, which are the main stages of tokenomics analysis.

We used the behavior algebra specifications for the formalization for the insertion modeling method [7] and the deductive or symbolic method in IMS based on the such external provers and solvers, as Presburger – omega [8], Fourier-Motzkin - reallib (our tool), cvc3 [9], z3 [10] and MathSAT [11].

We considered the composition of the language of the basic protocols along with the language of UCM diagrams [12, 13] as the language for the formal presentation of system specifications. We considered the set of formulas of first-order logic over polynomial arithmetic as a basic logical language.

All the basic conceptions, such as environment, agents, basic protocols, behavior-algebra, etc., are considered in the SKILLONOMY project formalization example described in the next sections of the article.

## 2 Formalization of the tokenomics model

SKILLONOMY project is an educational online platform that tokenizes productive activities in the learning process and is focused on gaining monetized online knowledge and skills. The SKILLONOMY ecosystem is built around an IT platform that allows participants to effectively build and administer the relationships that are related to training, investing and sharing experience.

Developing the SKILLONOMY project required a set of essential functions of the blockchain for ensuring a stable and efficient system that works[6].

The main purposes of the tokenomics model formalization of the SKILLONOMY project are:

- the search for modeling errors, such as finding failings or possible contradictions;
- the search for effective scenarios of the system in the model, etc.;
- the possibilities for analyzing and predicting the model; and
- the possibilities for analyzing the feasibility of project financing.

The process of the formalization of the tokenomic project consists of the following steps: selection of the agents and definition of their attributes corresponding to the level of abstraction demanded, definition of agents' actions and the design of agents' behavior.

According to the project requirements, we determined the next set of agents for this model: coaches, managers, node owners, the platform owner, holders of tokens and the stock exchange, and students. Six categories of students are described: the first agent includes students whose average grade is equal 1, the second agent includes students whose average grade is equal 2, the third agent includes students whose average grade is equal 3, the fourth agent includes students whose average grade is equal 4, the fifth agent includes students whose average grade is between 3 and 4 and the sixth agent includes students whose average grade is equal 5.

The agent description will be present in the IMS language in the following form:

```
PLATFORM_OWNER
{
SMInvestToken: (int) -> real,
tokenICOSTageEmission: (ICO_STAGE) -> real,
commonEmission: real,
RESERVE: real.
...}
```

The interaction between agents is performed by the Basic Protocols (BP).

For this model, we have more than forty protocols. Examples of two of them are provided below:

- **studentONE\_BuyTokens** — Starting from the seventh month (the end of the closed ICO), students (students whose average grade is equal 1) acquire tokens to replenish their skillmining account. Node receives cash income.

```
student-
tONE_BuyTokens=Operator(( (month>6) & (std_o.tokenAvailable<basicNeeds*percStdON) ) ->
<("Purchase of tokens by students one")>
(std_o.tokenAvailable:=std_o.tokenAvailable+percStdON* basicNeeds - std_o.tokenAvailable;
listPurchases(ONE):=listPurchases(ONE) + (percStdON * basicNeeds - std_o.tokenAvailable) * tokenPrice;
```



```

stock.tokens:=stock.tokens - (percStdON *basicNeeds -
    std_o.tokenAvailable);
stock.bought:=stock.bought + (percStdON *basicNeeds -
    std_o.tokenAvailable)

```

- **stageEmission** — emits tokens for sale in periods (SEED, PRE\_TGE, TGE\_OPEN\_SALE) in the first month of the period in which the emission is planned. In the precondition of these basic protocols we used the existential quantifier “Exist.”

```

stageEmission=Operator(Exist
(i:ICO_STAGE)((month=monthStartStage(i)))->
    <"Emission by period">
(platform.tokenICOSTageForSale(i):=
    platform.tokenICOSTageEmission(i);
platform.commonEmission:=platform.commonEmission -
    platform.tokenICOSTageEmission(i)))

```

At the highest level, the SKILLONOMY model can be represented as a sequential and parallel composition of behaviors in the following form (this is the expression of behaviors algebra):

```

B0 = (UnlockBeh; EmissionBeh; ReductionBeh; {SaleBeh || Skill-
    MiningBeh || StockExchange }; PriceBeh;
    AddNewStdBeh; B2),

```

where: UnlockBeh — behavior of token unlocking, EmissionBeh — behavior of token emissions, SaleBeh — behavior of token sale, ReductionBeh — behavior of recounting the number of students when they reach their limit of purchasing ability; StockExchange — behavior of buying and selling tokens for the agent holders, SkillMiningBeh — Skillmining behavior, PriceBeh — behavior of token price change, B2 — behavior for the month counter and AddNewStdBeh — behavior of recounting the number of students after the arrival of new users on the platform. Each of these behaviors, in turn, represents a finite sequence of protocols. As example, lets describe the EmissionBeh behavior:

```

EmissionBeh = stageEmission.EB1 + not_stageEmission.EB1,
EB1 = tokenHolders.EB2 + !tokenHolders.EB2,
EB2 = skillMiningInvest + not_skillMiningInvest

```

where stageEmission, not\_stageEmission, tokenHolders, skillMiningInvest and not\_skillMiningInvest are the basic protocols.

Initial values for the initialization of the environment are given in a special logic formula. The construction of a specific model involves the determination of specific values of the agents and the environment attributes. Some values were defined initially in the documentation, but other parts were determined by conducting relevant sur-

veys for target groups. The description, analysis and results from using the data obtained from the surveys is presented in the next section of the article.

### 3 Specific model. Simulation results

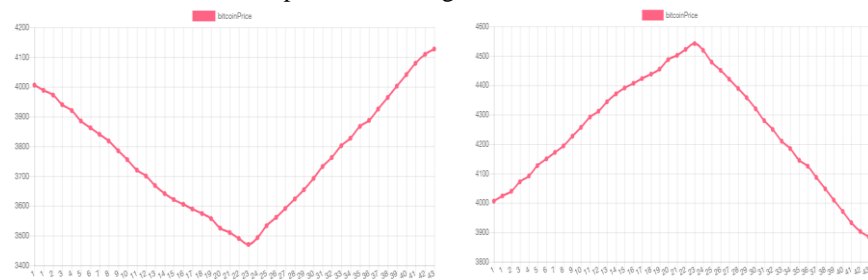
As described above, the construction of a specific model involves the determination of specific values of the agents and environment attributes. So, for example, we must determine the required ranges of the transfer of tokens between agents. Thus, it became necessary to conduct surveys, allowing us to determine the initial values of a number of attributes, such as the limit of students' ability to buy, the desire to sell to make a profit with an attachment to the time interval and the ratio of cashable profit to the income received, etc.

As a result of the simulation of the model and with the selection of different values of attributes, we were able to analyze the behavior of the SKILLONOMY model according to different bitcoin trends.

When we model the specifications, we simulated the activity of all agents that take part in such processes as sending and receiving tokens and selling and purchasing tokens on the stock exchange. In the process of modeling, we were able to monitor the dynamics of attributes and main tokenomic indicators.

We determined four different bitcoin trends: 1. The trajectory of bitcoin price is evenly falls up to the twenty-third month, and after this it evenly increases until to forty-third month; 2. The trajectory of bitcoin price evenly grows up to twenty-third month, and after this it evenly falls until to forty-third month; 3. There is uniform growth in bitcoin price; 4. There is a uniform fall in bitcoin price.

To better visualize the results we obtained, let us consider the behavior of the model according to first and second trends we noted. The trajectory of bitcoin price for first and second trend presented in Fig.1.

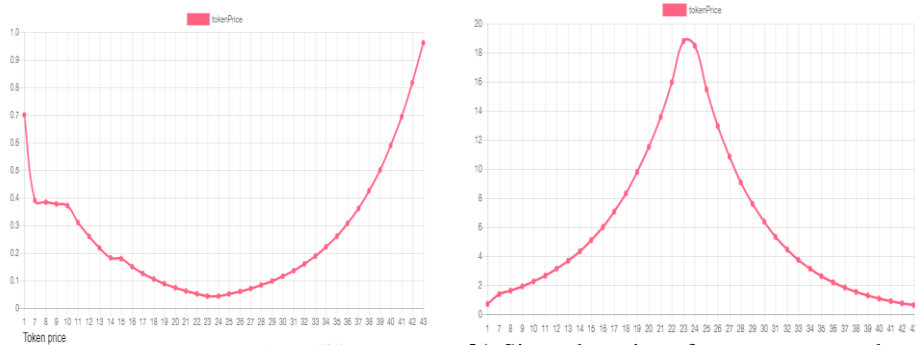


**a)** The initial price of bitcoin is 4006.1. From the first to the twenty-third month, the price of bitcoin falls to 3470.4. Between the twenty-third and the forty-third months, the price of bitcoin increases to 4127.4

**b)** The initial price of bitcoin is 4006.1. From the first to the twenty-third month, the price of bitcoin increases to 4541.8. Between the twenty-third and the forty-third months, the price of bitcoin falls to 3884.8

**Fig.1.** The trajectory of bitcoin price

The trajectory of the token price (based on the price of bitcoin and on the demand for a token inside the ecosystem) is represented in Fig.2.

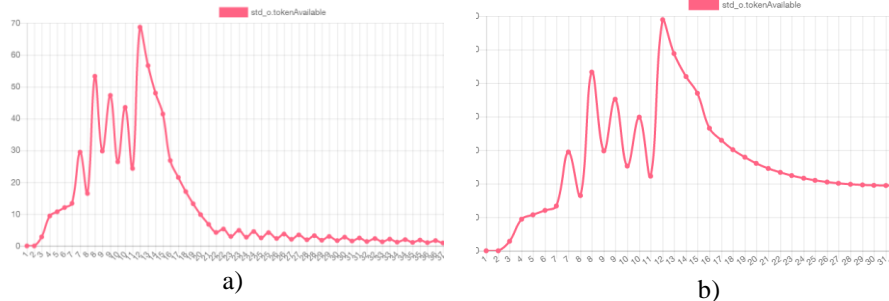


**a)** Since the price of an ecosystem token reacts to the fall of bitcoin price, the price of the token falls below the starting price up to twenty-third month. After this, the price evenly increases.

**b)** Since the price of an ecosystem token reacts to increases in bitcoin price, the price of the token increases up to the twenty-third month and then starts to fall almost to the initial price.

**Fig.2.** The trajectory of the token price

In our minds, the most interesting trajectory of the available tokens for students is the trajectory for students whose marks are equal (1), because the trajectory depends more on the bitcoins and the token prices than for other categories of students.



**Fig.3.** The trajectory of the token price

As we can see in Fig.3 (part a), the students in this category do not approach the limit of purchased ability immediately because the token price is not large. Therefore, from the twenty-third month we see a small amount volatility. The students buy the missing tokens for mining. As seen in the part b of Fig.3, when the price of tokens has increased and is quite high, students in this category begin to buy the missing tokens for mining. When they buy tokens, they exceed their purchasing ability and begin to leave the system. The number of students becomes so small that they have enough of what they need for mining. Therefore, we do not see volatility on this chart.

Users can come to these and other conclusions using this process of studying the different attributes of agents and changing the initial values used in this project. This

model allows changing hypotheses to evaluate the risks when selecting the worst conditions in the process of tokenomic modeling. One of most important advantages of tokenomic modeling is the opportunities to debug the system and to change the algorithm or boundary values of attributes to reach the demanded results.

## 4 Symbolic model

Unlike in concrete modeling, symbolic modeling provides us with opportunities to check the reliability and stability of our model.

The main feature of the system soundness is retaining the tokenomics indicators. Symbolic modeling cannot give us the opportunities to create charts as concrete modeling can, but symbolic modeling allows us to create formulae that characterize the monitored attributes. Thus, for this project all unknown parameters were considered in the supposed and desirable boundaries of the main indicators were checked.

As an example, let us consider such parameters as:

1) the price of a token, 2) the portion of the sold tokens that are open sale and 3) the purchasing ability of students.

In the given project they can be presented by the following formulas:

1)  $0.5 < \text{tokenPrice} < 6$ ; 2)  $(\text{pSale} \geq 0.01) \ \&\& \ (\text{pSale} \leq 0.5)$ ; 3)  $(\text{criticalLimit} \geq 10) \ \&\& \ (\text{criticalLimit} \leq 100)$ .

After we denoted the initial unknown parameters as variables, we can evaluate their boundaries, if possible. In the process of tokenomic modeling for these examples, we can obtain the following formulas:

1)  $\text{tokenPrice} = F1(p1, p2, \dots)$ , 2)  $\text{pSale} = F2(s1, s2, \dots)$ , 3)  $\text{criticalLimit} = F3(l1, l2, \dots)$ , where  $p1, p2, \dots$ ;  $s1, s2, \dots$ ;  $l1, l2, \dots$  are the unknown parameters of tokenomics. Proving that these parameters enter into the described intervals can confirm or refute the property. This kind of property is called a safety property.

Another strength of the algebraic method is the ability to consider the security of the project. We must analyze the malicious or undesirable actions and create an additional formalization in the UCM behavior and basic protocols and combine it with a positive scenario. As example, in this model such actions could include the massive purchase of tokens or the lowering of the price by some subjects in market, etc.

The demanded boundaries of critical attributes shall be retained for stability.

## Discussion and Conclusions

Using the proposed approach provides us with opportunities to study the reliability, stability, safety and properties of the models. Symbolic modeling allows us to evaluate the possible risks and to avoid losing money at critical moments, such as when the price of bitcoin falls, etc. It is possible to take into account the different scenarios of behavior to determine some predictions.

In the process of formalizing such models, there may arise some problems at the interdisciplinary level. Also, due to the complexity of the model, the problem of taking into account of possible scenarios may also arise. It is possible, that multiple at-

tributes with undefined values may appear, the exact definition of which will be required for adequate model building. Accordingly, there is a need for additional research. In this case, as mentioned above, questioning and analysis methods were used to determine the initial values of some attributes for SKILLONOMY.

## Acknowledgements

We would like to thank the company garuda.ai [14] for the opportunity to work with the platform for modeling, formal verification and testing of Blockchain / DLT systems behavior and cybersecurity research for our research and experiments in the modeling area. We are also grateful to the Glushkov Institute of Cybernetics of NAS of Ukraine for the theoretical and practical results in the field of verification that were used as a basis for our studies of formalization and algebraic modeling in the tokenomics projects area and to the Kherson State University for the active supporting of Insertion Modeling System.

## References

1. Kampakis, S.: Three Case Studies in Tokenomics. *The JBBA*, 1(2), 79-82 (2018).
2. Token Engineering Fundamentals, <https://www.slideshare.net/MichaelZargham/token-engineering-presentation-5-1318>.
3. ABM, <https://github.com/ShrutiAppiah/Simulating-an-Economy-ABM>.
4. Appiah, S.: Decentralized Organizations as Multi-Agent Systems - A Complex Systems Perspective. Technical Report (2017).
5. Letichevsky, A., Letychevskiy, O., Peschanenko, V.: Insertion Modeling and Its Applications. *Computer Science Journal of Moldova* 24 (3), 357-370 (2016).
6. SKILLONOMY, <https://SKILLONOMY.org/ru>.
7. Letichevsky, A., Gilbert, D.: A Model for Interaction of Agents and Environments. In: Bert D., Choppy C., Mosses P.D. (eds) *Recent Trends in Algebraic Development Techniques*. WADT 1999, LNCS, vol. 1827, pp.311-328. Springer, Berlin, Heidelberg (1999).
8. Omega: a solver for quantifier-free problems in Presburger Arithmetic, <https://coq.inria.fr/refman/addendum/omega.html>.
9. CVC3, <https://cs.nyu.edu/acsys/cvc3/>.
10. Z3Prover, <https://github.com/Z3Prover/z3>.
11. Mathsat, <http://mathsat.fbk.eu/>.
12. ITU-T Recommendation, Z.151, User Requirements Notation (URN) – Language definition, <https://www.itu.int/rec/T-REC-Z.151/en>.
13. Letichevsky, A., Kapitonova, J., Letichevsky Jr, A., Volkov, V., Baranov, S., & Weigert, T.: Basic protocols, message sequence charts, and the verification of requirements specifications. *Computer Networks*, 49(5), 661-675. (2005).
14. Gruda AI BV, [www.garuda.ai](http://www.garuda.ai).

# Formalization and Algebraic Modeling of University Economics

Volodymyr Peschanenko <sup>[0000-0003-1013-9877]</sup>, Maksym Poltoratskyi <sup>[0000-0001-9861-4438]</sup>,  
Karina Pryimak <sup>[0000-0001-7922-9534]</sup>

Kherson State University, Universytets'ka St. 27, 73000, Kherson, Ukraine  
{vpeschanenko, mpoltorackiy, priymak.karina}@gmail.com

**Abstract.** The article discusses the approach to modeling economic processes at the university using the methods of algebraic modeling and insertional modeling. The formal model of the economic processes of the university is presented in the article.

**Keywords:** insertion modeling, formal methods, economic modeling, formalization of the economic model.

## 1 Introduction

Modeling is one of the main methods of knowledge, is a form of reflection of reality and is to ascertain or reproduce certain properties of real objects, objects and phenomena using other objects, processes, phenomena, or using an abstract description in the form of an image, plan, map, a set of equations, algorithms and programs.

The possibilities of modeling, that is, the transfer of the results obtained during the construction and study of the model to the original, are based on the fact that the model in a certain sense reflects (reproduces, models, describes, simulates) some of the object features of interest to the researcher. Modeling as a form of reflection of reality is widespread, and a fairly complete classification of possible types of modeling is extremely difficult, if only because of the ambiguity of the concept of "model", widely used not only in science and technology, but also in art and in everyday life.

## 2 Overview

Consider the list of software products for modeling of economic-mathematical and mathematical models.

**The Maple** program is still one of the leaders among universal systems of symbolic calculations. It provides the user with a convenient intellectual environment for mathematical research at any level and is particularly popular in the scientific community. Maple's symbol analyzer is the strongest part of this software [1-2]. Maple provides a convenient environment for computer experiments, during which different approaches to the problem are tried, particular solutions are analyzed, and if pro-

programming is necessary, fragments requiring special speed are selected. The package allows you to create integrated environments with other systems and high-level universal programming languages. In this package Maple is not like a traditional programming environment, where a rigid formalization of all the variables and actions with them. Here, the choice of suitable types of variables is automatically ensured and the correctness of operations is checked, so that in the general case, the description of variables and the strict formalization of the record are not required. The Maple package consists of a kernel (procedures written in C and well optimized), a library written in Maple, and a developed external interface. The kernel performs most of the basic operations, and the library contains many commands — procedures performed in the interpretation mode. The Maple interface is based on the concept of a worksheet or a document containing I/O lines and text, as well as graphics [2].

**MATLAB** is one of the most powerful data processing packages today. The name stands for Matrix Laboratory. MatLab system refers to the average level of products intended for symbolic mathematics. MatLab is one of the oldest, thoroughly developed and time-tested systems for automation of mathematical calculations, built on an expanded view and application of matrix operations [3]. However, the syntax of the system programming language is thought out so carefully that this orientation is almost not felt by those users who are not directly interested in matrix calculations. Despite the fact that MatLab was originally intended solely for computing, in the process of evolution, in addition to computing tools, under the license for MatLab, Waterloo Maple acquired the core of symbolic transformations, as well as libraries that provide functions unique to MatLab for mathematical packages [4]. For example, the well-known library Simulink, realizing the principle of visual programming, allows you to build a logic diagram of a complex control system from standard blocks alone, without writing a single line of code. The MatLab system also has ample opportunities for programming. Its C Math library (MatLab compiler) is object and contains over 300 data processing procedures in C. Inside the package, you can use both the procedures of the MatLab itself and the standard procedures of the C language, which makes this tool a powerful tool for developing applications (using the C Math compiler, you can embed any MatLab procedures into ready-made applications).

**The Powersim** package is an excellent tool for creating continuous models. However, from the point of view of discrete modeling, it is not effective enough. Powersim is suitable for users who need to build continuous models and who want to learn a rather complex Systems Dynamics notation. The Powersim package stands out among the other packages with the ability to process arrays and support teamwork, as well as the fact that it contains a library with a large number of functions [5]. Arrays are also convenient for creating models, in the construction of which the levels change their state, and the developer wants to follow these changes. Powersim includes more than 150 functions, divided into 16 groups, including financial, mathematical, statistical, graphic and historical. Like other packages, Powersim uses animation tools when running models. Key parameters, charts and tables can be displayed directly on the simulation screen, thereby simplifying the viewing of results. The Multiuser Game feature allows multiple users to simultaneously run a model to work together on it. Powersim contains many standard Windows tools, such as menus and

toolbars, and supports Dynamic Data Exchange (DDE) and Object Linking and Embedding (OLE) technologies [6]. For example, using OLE, a developer can embed a Powersim model into a document created by a word processor, so that changes to the model are automatically reflected in the document. The simulation language Powersim can be used to build models of both simple and complex systems. Nevertheless, Powersim is quite a powerful tool that allows you not only to quickly and visually build and analyze system-dynamic models, but also to demonstrate in an accessible form the simulation results to a wide range of people who are not necessarily experts in mathematical modeling. Powersim belongs to the family of imitation modeling languages (Dynamo, Stella / iThink, Vensim, Rusim), which rather quickly and efficiently allows you to master the technique of simulation modeling to representatives of not only the natural sciences, but also the humanities.

**The iThink** software product was developed specifically for modeling system dynamics, the company ISee systems, inc. The program allows users to run models created as graphical representations of the system using four fundamental building blocks [7]. Ithink is one of the most powerful products we are considering. From the point of view of continuous modeling, it lags behind Powersim, but it is better to support discrete modeling. In addition, the Ithink package is equipped with excellent tutorials and documentation, as well as a large number of blocks for building a model. The package is available in two versions - Basic and Authoring [8]. The version of Authoring, which was compared with other packages, allows the developer to include in the ruler model with engines and other model management tools, as well as enter diagrams and other images directly into the model, so that users can control the modeling process and immediately see its results. Like Powersim, Ithink uses the Systems Dynamics notation, which is mainly focused on continuous modeling. To implement this system, four types of structures are used: stations, streams, converters, and connectors corresponding to the connections. The Ithink package offers the developer a list of 14 valid variables for defining mathematical relationships. Ithink provides a sensitivity analysis of the model by launching it repeatedly with various input parameters. The results of each run are displayed in a separate line of the output diagram. Baseline data are the main types of distributions used for statistical analysis or a chart. When a model is executed, Ithink uses animation tools that move stations located at different levels in accordance with the model logic. Although the choice of formats for outputting results in Ithink is not as wide as in Extend, from this point of view it is superior to both Powersim and Process Charter.

**Arena**, developed by Systems Modeling Corporation software for simulation, allows you to create mobile computer models. The basis of Arena technologies is SIMAN modeling language and Cinema Animation system. SIMAN, first implemented in 1982, is an extremely flexible and expressive modeling language [9]. He is constantly improving by adding new features. To display the simulation results used animation system Cinema animation. Arena is equipped with a convenient object-oriented interface and has amazing possibilities for adaptation to various subject areas. In general, the system is extremely easy to use. The Arena simulation model includes the following main elements: Create and Dispose, Process and Queue [10]. Create are elements from which information or objects come into the model. The rate



at which data or objects are received from a source is usually given by a statistical function. A drain is a device for receiving information or objects. The concept of a queue is close to the concept of a data warehouse - this is the place where objects are waiting to be processed. The processing time of objects (performance) in different processes may be different. As a result, some processes may accumulate objects waiting for their turn. Often, the purpose of simulation is to minimize the number of objects in the queues. The type of queue in the simulation model can be specified. A queue can be similar to a stack — the objects that arrived last in the queue are sent first for further processing (LIFO: last-in - first-out). An alternative to the stack can be sequential processing, when the objects that arrive first (FIFO: first-in - first-out) are sent first for further processing. More complex queue processing algorithms can be specified. Processes are an analogue of work in a functional model. In the simulation model, the performance of processes can be specified. Arena is a simulation system that allows you to create mobile (simulation) computer models, using which you can adequately describe and predict real processes.

**Extend + BPR package.** The Extend package as a universal modeling tool is convenient for reorganizing various business processes. To create models in a package, a block development environment is used, which is much easier to use than the Systems Dynamics notation for Powersim and Ithink packages. The Extend package, which has the means of building continuous and discrete models, a wide range of preformed blocks, support from third-party suppliers and the possibility of expansion, is a powerful product from the ones we are considering. Initially, it was focused on the convenient user interface of Macintosh computers [11], then transferred to the Windows environment using the Win32 application programming interface, and now even performs the installation of Win32 on systems that do not have Win32. The package is available in four versions: Basic, Extend + BPR (Business Process Reengineering), Extend + Manufacturing and Extend + BPR + Manufacturing [12]. Additional BPR and Manufacturing facilities include a number of features for vertical markets. In addition, there are many third-party products that support Extend and are targeted to specific applications. The basic package of Basic includes more than 90 preformed blocks combined into libraries, of which Discrete-Event, Generic and Plotter are most often used. The Discrete-Event library includes various actions, queues, gateways, and timers. The Generic library contains random number and source data generators, files for input and output information, and blocks for mathematical, boolean, and financial data. The Plotter library consists of blocks for creating output diagrams and tables. The remaining libraries have a special purpose, for example, they collect statistical information. BPR and Manufacturing packages are provided with additional libraries. In addition, Extend has a built-in language Modl, which allows the developer to build specialized blocks. Selecting a block from the Discrete-Event library automatically builds a discrete model; otherwise, a continuous model. The Extend package is equipped with authoring models creation functions, with the help of which the developer includes text, geometric images and control blocks in the model window so that users can independently modify the model. To control the process of modeling and displaying the results on the display, a tool based on the notepad principle is used. The Extend package provides detailed user guidance, a tutorial, and model examples

from a wide variety of areas of activity that can serve as the basis for creating new models, which undoubtedly facilitates the modeling process.

We propose an algebraic approach to economic modeling that is implemented in the scope of the insertion modeling system (IMS) [13]. Insertion modeling focuses on building models and studying the interaction of agents and environments in complex distributed multi-agent systems [13,14].

### 3 Insertion Modeling System

Insertion modeling is concerned with the construction of models and the study of the interaction of agents and environments in complex distributed multiagent systems.

Environments is an agent that has a dip function. More precisely, the environment is the set of  $\langle E, C, A, \text{Ins} \rangle$ , where  $E$  - is the set of environment states (identified with behaviors),  $C$  - is the set of actions of the medium,  $A$  - is the set of actions of agents immersed in the environment,  $\text{Ins}: E \times F(A) \rightarrow E$  - immersion function. Here  $F(A)$  - is the complete algebra of the behavior of agents with the set of actions  $A$ . Thus, every medium  $E$  admits the immersion of any agent with the set of actions  $A$ .

The behavior of agents is described by the algebra of behavior. The algebra of behavior has several basic operations: the prefixing  $a.u$  and the non-deterministic selection  $u + v$ , where  $a$  is the action,  $u$ , and  $v$ -behavior. Parallel and sequential composition ( $u \parallel v, u; v$ ).

It should also be noted that there are two terminal constants in algebra of behavior: successful completion and dead-end behavior  $0$ .

Basic protocols are used to represent the insertion models. The general theory of basic protocols is presented in [14]. The methods of verification of requirements and specifications of distributed systems in the field of telecommunications, embedded systems and real-time systems have been developed with the help of the language of basic protocols.

$\forall x (Ux \rightarrow \langle P \rangle Vx)$ , where  $U(x)$  is the precondition that defines the state when the protocol can be used;  $V(x)$  is the postcondition that defines the transition to a new state;  $P$  is the process that illustrates this transition. The basic idea of the theory of basic protocols is presented in [15].

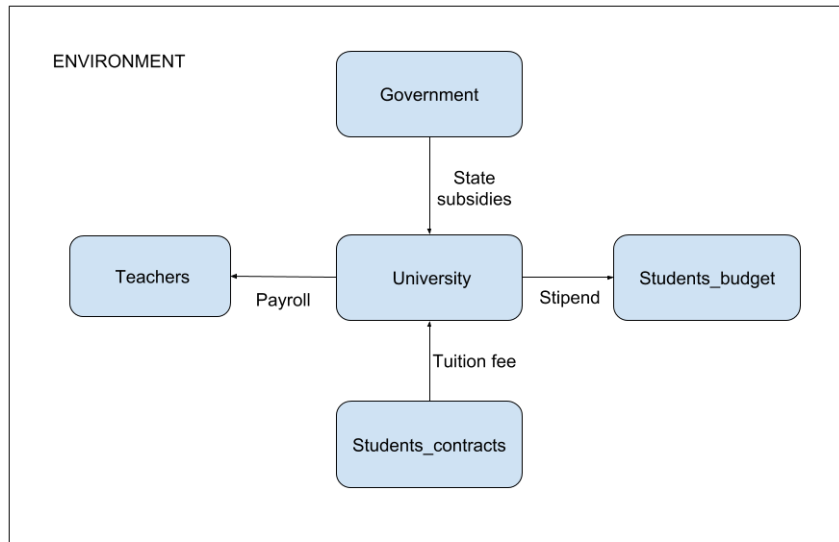
Further, let's consider the formalization of the University's economy using the methods of algebraic programming and insertion simulation.

### 4 Formalization of economic model of university

The process of formalizing the economy of a university consists of several stages: the selection and description of agents that are involved in the model, the definition of their attributes corresponding to the required level of abstraction, the definition of agent actions and the design of agent behavior.

Based on the model requirements, we selected the following types of agents: country, university, teachers (professor, associate professor, teacher, assistant), state employees, contract service students.

The list of agents and their interaction with each other can be represented by the following diagram.



**Fig. 1.** Diagram of agents and their interaction with each other

The main objectives of the formalization of the university's economic processes are:

1. The search for modeling errors, such contradictions, deadlocks
2. Search for effective system scenarios in the model, etc.
3. Opportunities to analyze and predict the model;

The initial stage of modeling is the definition of both agents and their attributes. Agents in among inertial modeling can be represented as follows, consider an example of the description of the agents of the university and the state:

```

GOVERNMENT:obj (
score:real
.....
),

UNIVERSITY:obj (
score:(Score_TYPE)->real
.....
)
  
```

It should also be noted that the score attribute of the university agent has an enumerated type, this is based on the requirements, since the university has two accounts: special and basic, this fact among inertial modeling can be represented as follows:

```
Score_TYPE: (SPECIAL, GENERAL)
```

The interaction between agents is carried out through the language of the basic protocols [15]. The following are examples of the basic protocol formalizations and their description in natural language:

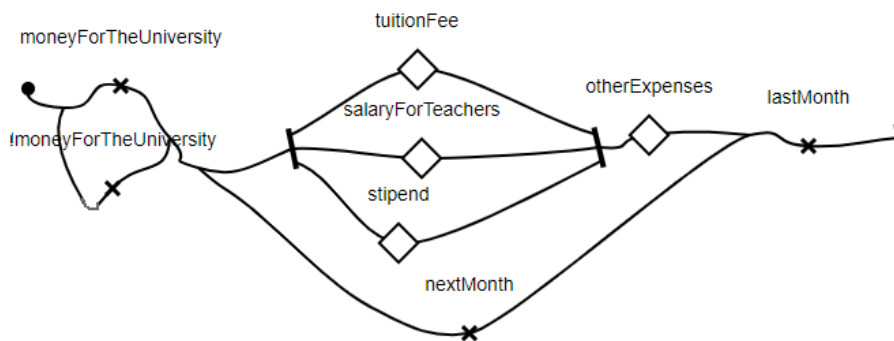
**Table 1.** The examples of the basic protocol formalizations

Basic protocol	Description
<pre><b>calcTuitionFee</b> = Operator(Forall(i:int, j:int) ( (i&gt;=1&amp;i&lt;=2&amp;j&gt;=1&amp;j&lt;=max&amp;(current Month=1)) -&gt; &lt;"calculation ratio of tuition fee by month"&gt; (sumTuitionFee:= sumTuition- Fee+(countStudents *tuitionFee(i, j)*rationStd(i, j) )))</pre>	<p>Calculation of the monthly amount of tuition fees for all students of contract. It is important to note that: tuitionFee (i, j) is the cost of tuition for one month according to the distribution "department / course" where,</p> <ul style="list-style-type: none"> <li>i - department; j - course.</li> <li>tuitionFee(1,1)=1200</li> <li>tuitionFee(1,2)=1300</li> <li>....</li> <li>tuitionFee(2,2) = 1700</li> </ul>
<pre><b>tutionFee</b> = Operator( (currentMonth&gt;=1 &amp;&amp; (~(currentMonth=11) &amp;&amp;( ~(currentMonth=12)) ) -&gt; &lt;"Tuition fee"&gt; (univ.score(GENERAL):=univ.score(GRNERAL) +sumTuitionFee*coef; univ.score(SPECIAL):=univ.score(SPECIAL) + sumTuitionFee * coef))</pre>	<p>Tuition fees, the amount that is calculated in the protocol is transferred to the university account. calcTuitionFee.</p> <ol style="list-style-type: none"> <li>1. 50% - transferred to a special fund.</li> <li>2. 50% is transferred to the general fund.</li> </ol>
<pre><b>sumSalary</b>=Operator(Forall (i:Teachers_TYPE) ( (i&gt;=1&amp;i&lt;=4 &amp; (currentMonth&gt;1))- &gt; &lt;"calculation ratio of salary by month"&gt;</pre>	<p>The calculation of the monthly amount that the university spends on salaries for faculty members, where:</p> <ul style="list-style-type: none"> <li>Salary(Professor) = n1</li> <li>Salary(Docent) = n2</li> <li>.....</li> <li>Salary(Assistant)=n3</li> </ul>

Basic protocol	Description
<pre>(sumSalary:=sumSalary + countTeachers * Salary(i) )</pre>	<p>It should be noted that Salary (Professor) = n1 - the value that the university spends to pay salaries for all professors of the university.</p>
<pre><b>salary</b> = Operator( (currentMonth&gt;=1)-&gt; &lt;"payment of wages"&gt; (univ.score(GENERAL):=univ.score(GENERAL) - coef * sumSalary; univ.score(SPECIAL):=univ.score(SPECIAL) - coef * sumSalary; coach.score:=coach.score + sumSalary) )</pre>	<p>Payment of wages.</p>

At the highest level of agent behavior can be represented as follows, and fig. 2. Presents a graphical version of the behavior algebra. Consider each of the subprocesses in more detail:

1. **tuitionFee** - the process of paying for tuition; contract-based students pay university tuition fees.
2. **salaryForTeachers** - payroll process.
3. **stipend** - scholarship payment.
4. **otherExpenses** - a process representing unplanned expenses of a university (business trips, organization of conferences, and so on).



**Fig. 2.** Graphic representation of behavior algebra

It should be noted that the tuitionFee, salaryForTeachers, otherExpenses processes are parallel processes. The diagram presented in fig. 2, can be represented in algebraic form as follows:

```

B0 = moneyForTheUniversity . EB1 + !moneyForTheUniversity
    . EB1,
EB1 = (
{tuitionFee || salaryForTeachers || stipend}; otherExpenses; EB2
),
EB2 = nextMonth . B0 + lastMonth . Delta

```

Initial values for model initialization are given in a special logical formula. Building a model with specific values includes defining specific values for agents and attributes of the environment.

In contrast to a specific model, the symbolic one allows us to analyze the formal model for stability and stability. To test stability, the first step is to select the indicator of stability of the economic model. Since, the tuition fee is directly related to the number of applicants, and often changes, we have chosen deltaPriceEducation as a parameter of stability. This parameter is very important because a very small average tuition fee will negatively affect the economy of the university, and a very high one will affect the number of applicants. In this project, this fact can be described as follows:

```
2000 >= deltaPriceEducation >= 1000
```

In the process of modeling, we can get the following formulas;  $\text{deltaPriceEducation} = P(p_1, p_2, \dots, p_n)$  - where,  $p_1, p_2, \dots, p_n$  are unknown parameters for the model. Proof that these parameters fall within specified intervals, can confirm or refute the properties of the model.

## 5 Conclusions

Using the proposed approach gives us the opportunity to study the reliability and stability of economic models to check the safety and properties of models. In the process of formalizing such models, there may be some problems associated with the interdisciplinary level. The article presents a method for analyzing and modeling economic models, provided a formal model of the economy of the university. This approach makes it possible to evaluate the model, and to take into account various scenarios of behavior. Using the methods of algebraic programming, we can analyze models on inconsistencies and seek non-determinism and deadlocks.

## References

1. Gander, W., Gander, M. J., Kwok, F.: Scientific computing: an introduction using Maple and MATLAB. Springer, Heidelberg (2014).
2. Biran, A., Breiner, M.: MATLAB for Engineers. Pearson Education, Harlow, Essex (2002).
3. Herniter, M. E.: Programming in MATLAB. Brooks/Cole Publishing Co, Florence, Kentucky, U.S.A (2000).
4. Malczynski, L. A.: Best practices for system dynamics model design and construction with Powersim studio. Sandia National Laboratories, Albuquerque, New Mexico and Livermore, California (2013).
5. Giammarini, M., Orcioni, S., Conti, M.: Powersim: power estimation with SystemC. In: Solutions on Embedded Systems, pp. 285-300. Springer, Dordrecht (2011).
6. Sumari, S., Ibrahim, R., Zakaria, N. H., Ab Hamid, A. H.: Comparing three simulation model using taxonomy: System dynamic simulation, discrete event simulation and agent based simulation. International Journal of Management Excellence 1(3), 54-59 (2013).
7. Murphy, B.P., Randolph, C.M.: Simulation packages today: new user classes and order-of-magnitude breakthroughs in development costs. Computational statistics & data analysis 16(4), 471-479 (1993).
8. Hammann, J. E., Markovitch, N. A.: Introduction to Arena [simulation software]. In: Proceedings of the Winter Simulation Conference, pp. 519-523. IEEE (1995).
9. Batarseh, O., McGinnis, L. F.: System modeling in SysML and system analysis in arena. In: Proceedings of the Winter Simulation Conference, p. 258. IEEE (2012).
10. Krahl, D.: An introduction to Extend [hierarchical simulation modelling tool]. In: Proceedings of the Winter Simulation Conference, pp. 538-545. IEEE (1994).
11. Krahl, D.: Extend: the Extend simulation environment. In: Proceedings of the 34th conference on Winter simulation: exploring new frontiers, pp. 205-213. IEEE (2002).
12. Letichevsky, A. A., Letychevskiy, O. A., Peschanenko, V. S.: Insertion modeling system. In: International Andrei Ershov Memorial Conference on Perspectives of System Informatics, pp. 262-273. Springer, Berlin, Heidelberg (2011).
13. Letichevsky, A., Gilbert, D.: A model for interaction of agents and environments. In: International Workshop on Algebraic Development Techniques, pp. 311-328. Springer, Berlin, Heidelberg (1999).
14. Letichevsky, A., Kapitonova, J., Letichevsky Jr, A., Volkov, V., Baranov, S., Weigert, T.: Basic protocols, message sequence charts, and the verification of requirements specifications. Computer Networks 49(5), 661-675 (2005).

# Formalization of the Model of Management of the Technological Innovations

Vitalina Babenko<sup>[0000-0002-4816-4579]</sup>

V.N. Karazin Kharkiv National University, 4 Svobody Sq., Kharkiv, 61022, Ukraine  
vitalinababenko@karazin.ua

**Abstract.** *Research goals and objectives:* to describe the discrete dynamic system consisting of technological innovation (TI), to formulate a meaningful statement of the goal of managing TI taking into account risks, to develop a formal statement of the task of TI-management with risks. It is subject to the influence of controlled parameters (controls) and uncontrolled parameter (vector of risk or interference).

*Subject of research.* The process of formalization of management of technological innovations is investigated. To describe the process of managing technological innovation, it is needed to know the parameters of the system. The process of management of technological innovations is described by a discrete vector (recurrent) equation. The phase vector characteristic of management of technological innovations includes three components: the same unrealized products for the period, products for the period, and flow rates for the next period.

*Research methods used:* to build an economic and mathematical model, a class of deterministic models is used. Its dynamics is described by a vector linear discrete recurrent relation.

*Results of the research:* The obtained model of management of the TI can be used for economic-mathematical modeling and the practical use of optimal processes for predicting data management. The development of modular models can serve as the basis for the development of software and hardware systems for training programs that are effective in the operational strategies of innovative technologies.

**Keywords.** technological innovation, dynamic optimization, model formalization, deficiency conditions.

## 1 Introduction

The researching of the task of a management of the technological innovations (TI) requires the decision of a dynamic economic-mathematical model, taking into account the presence of control influences. It has uncontrolled parameters as risks, modelling errors, etc. and a lack of information. Existing approaches for solution this problem is based mainly on static models and use a stochastic modelling apparatus. However, its application requires knowledge of the probability characteristics of the basic parameters of the model and special conditions for the providing of the considered process.



Note for using of the stochastic modelling apparatus, very stringent conditions are needed, which in practice are usually not feasible in advance.

In this article a deterministic approach to formalize the initial dynamic task of management of the TI at a given point in time, taking into account the presence of risks is proposed. In this case, the risks in the TI system of management will be understood as the factors which has negatively or even catastrophically affect on the results of the considered processes in it.

## **2 Analysis of Literature and Problem Statement**

To formalization of the model of TI-management it is necessary research the procedure of their identification. The term "identification" has become widely used as one of the basic sections of the theory of control in the 50s of the last century. Today, researchers from many spheres of science and technology, in particular, for the synthesis of control systems, consider the problem of building adequate, efficient models. One of the founders of the theory of identification is Professor P. Eikhoff [1]. Subsequently, other approaches to task of the problems of constructing models for different classes of objects, methods of their description, signals used in the case of different approaches and algorithms of identification, other problems of construction and analysis of models of processes or systems. In addition, among the most significant works devoted to the questions of the identification of dynamic systems, one should point out the research of D. Grope [2], E.P. Sage and J.L. Melsa [3], L. Leung [4], and also Y.Z. Tsipkin [5], N.S. Raybman [6], S.E. Steinberg [7] and others.

The active development of computer technology in recent decades has led to the emergence of new algorithms and software tools designed to automate professional activities. This significantly affected the methods of solving identification problems. The using of specialized software for scientific, technical and engineering calculations, on the one hand, enables us to learn the studied industry more deeply. At the same time transforming the main part of tasks for the researching, debugging of algorithms and programs for the correct statement of the problem. Usually this frees the researcher from solving many related issues: confirmation of the model validation, studying the identification error, the properties from received estimates, etc. On the other hand, the pace of software development is quite high. However, the comprehension of the obtained results and their competent use is often impossible. There is a certain contradiction between the ease of execution of a large number of rather complicated tasks, rapid achievements of results and insufficient understanding of their content. This leads to the impossibility of their further effective use [8-10].

Construction of economic and mathematical models of one or another type based on the obtained results of observations on the behavior of objects and the researching of their properties is the main content of the formalization problem.

### **3 The Meaningful Statement of the Task of Management of the Technological Innovations**

The purpose of the paper is to research of the TI-management with the influence of the risks and the formalization

of the model of the management of TI for the solving of a problem of identifying parameters of the linear dynamic system. It provides the development of a method that allows combining the procedures for solving multidimensional systems of the linear algebraic equations and interpolation of output data. In this case, the goal is to evaluate the parameters that are missing in separate periods.

To achieve the research task, the following objectives were set:

- to formulate a meaningful statement of the goal of managing TI taking into account risks;

- to develop a formal statement of the task of TI-management with risks.

TI involves the transition to production based on the innovation process. This process takes into account various types of factors of production, raw materials, options for the using and storage of materials, intermediate and final products, the influence of various internal production and external factors, including risks, as well as other components of the technological process. It can consist of certain technological ways of organizing production. They provide using of exist or replacement (full or partial) of technological equipment.

Management of TI is carried out in separate periods of life cycle of the innovation during their implementation. Management of TI includes the value of production volumes of new products, the vector of replenishment of material and labor resources for its production and the vector of investments for the providing of TI [11, 12]. They form a management scenario for relevant innovation. There is the possibility of using different scenarios of innovation management, depending on the variation of the values of its respective components.

It is necessary to implement such rational management of TI with the appropriate scenario for a given time interval of its life cycle by choosing from a variety of alternatives to possible influence of management [13]. In this case, the overall performance criterion should be maximum [14]. Moreover, if several implementation options of various TI are considered based on relevant innovation processes, then you must also make a choice between them and find rational management according to the chosen criterion [15].

Having developed a meaningful economic-mathematical model of TI management, let us turn to its formal formulation [16].

### **4 Formulation of the Task of Management of the Technological Innovations in the Presence of Risks**

Let us introduce the designation: let it be  $\bar{x}(t) = (x_1(t), x_2(t), \dots, x_n(t))' \in \mathbf{R}^{\bar{n}}$  – a phase vector that characterizes the state of management of technological innovations (the

availability of production volumes of the enterprise, financial, investment, technological, other productive resources, etc.) in the period  $t$  [17].

To describe the process of managing technological innovation, it is necessary to know the initial values of system parameters (at the beginning of the investigated time interval). Consider its structure. It includes volumes of products, other initial productive resources, etc., as well as investments aimed at TI [18]. At the expense of initial investments  $I_0$ , the purchase of equipment, production resources, etc. necessary for the "launch" of technological innovation. Since the volume of initial investment is a key factor for the implementation of the innovative technological process, in the phase vector  $\bar{x}(0)$  we select them separately, that is  $\bar{x}(0) = \{x_0, I_0\}$ .

The process of controlling TI is described by a vector discrete (recurrent) equation:

$$\bar{x}(t+1) = A(t)\bar{x}(t) + B(t)\bar{u}(t) + C(t)\bar{v}(t), \quad \bar{x}(0) = \{x_0, I_0\} \quad (1)$$

where  $t \in \overline{0, T-1} = \{0, 1, 2, \dots, T-1\}$  – discrete moments of time, divided by the period in the month, quarter, year, in which the choice of management is carried out;  $\overline{0, T}$  – a given time interval ( $T > 0$  and integer);

$\bar{x}(t+1) \in \mathbf{R}^{\bar{n}}$  – a phase vector that characterizes the state of management of TI over a period of time  $(t+1)$  and consists of vectors of volumes of production, inventories, costs, financial resources, and investment volumes formed over a period of time  $(t+1)$  (stocks in the period  $(t+1)$ ).

Consider the formation (1) by the example of the vector of production volumes of the enterprise:  $x_i(t+1)$  – is the quantity of the  $i$ -th type of products  $i \in \overline{1, n}$  that formed in the warehouse before the beginning of the time period  $(t+1)$  (product stocks in the period  $(t+1)$ ), which is formed from the stocks  $x_i(t)$  of the previous period of time and produced at the enterprise products for the period  $t$ .

Equation (1) consists of three components, which we shall consider below (the balances of unrealized output during the period, manufactured products in the period and the impact of risks for the period under study).

*Balances of unrealized products during the period  $t+1$ .*

Note that if at the beginning of the time period  $t$  in the warehouse there were stocks in the number  $x(t)$ , then by the end of this period, that is, before the beginning of the time period  $t+1$ , only the part that is equal will be available for sale equal to  $A(t)\bar{x}(t)$ ;

$A(t) = \|a_{ii}(t)\|_{i \in \overline{1, n}}$  – diagonal matrix characterizing the implementation of products (the matrix of "implementation") over a period of time  $\overline{t, t+1}$ ;

$\bar{x}(t) = (x_1(t), x_2(t), \dots, x_n(t))' \in \mathbf{R}^n$  – the vector of product stocks in the period  $t$  ( $t \in \overline{0, T-1}$ ), in which each  $i$ -th coordinate  $x_i(t)$  denotes the output of the  $i$ -th form  $i \in \overline{1, n}$  ( $n$  – the total number of produced products types),  $\mathbf{R}^n$  –  $n$ -dimensional vector space of column vectors.

*The products are manufactured in the period  $t+1$  (vector  $B(t)\bar{u}(t)$ ),*

where  $\bar{u}(t) \in \mathbf{R}^p$  – the vector of management of innovation technology (managerial influence), the components of which are the intensities of using the  $j$ -th technological method of production (according to the corresponding innovation technology) in the period  $t, p \in \mathbf{N}$ , for which each  $j$ -th coordinate  $u_j(t)$  is the value of the volume of material and labor resources and investment production for innovation technology ( $j \in \overline{1, n}$ ),  $\forall t \in \overline{0, T-1}$   $\bar{u}(t) \in U_1$ ,  $U_1$  – a finite set of alternatives that limits the resource of managerial influence;

$B(t) = \|b_{ij}(t)\|_{i \in \overline{1, n}, j \in \overline{1, p}}$  – "technological matrix" of production, components of which can be represented in the  $j$ -way that corresponds to the organization of production in the period  $t (t \in \overline{0, T-1}, T > 0)$ , which is characterized by the vector  $(b_{1j}(t), b_{2j}(t), \dots, b_{nj}(t))$  of the resources cost for the production of the unit volume of production of the  $i$ -th type ( $i \in \overline{1, n}$ ).

If  $b_{ij}(t) < 0$ , then  $b_{ij}(t)$  determines the consumption of  $i$ -th ingredient during the  $j$ -th mode of production in a period of time.

If  $b_{ij}(t) > 0$ , the quantity  $b_{ij}(t)$  determines the release of the  $i$ -th ingredient during the  $j$ -th mode of production in the period  $t$ .

An add-on that takes into account the impact of risks, modelling errors on products in the period  $t+1$  (vector  $C(t)\bar{v}(t)$ ), where  $\bar{v}(t) \in \mathbf{R}^q$  – vector of risks that affects the production and storage of products, that is, the process of forming a vector  $\bar{x}(t+1)$   $q \in \mathbf{N}$ . For example, investment payments (or their lack of remuneration), lack of delivery of materials, damage to agricultural products during storage or transportation, non-compliance with quality requirements for raw materials or finished products, insufficient investments, etc.;  $\forall t \in \overline{0, T-1}$   $\bar{v}(t) \in V_1$  – convex, closed and bounded polyhedron in  $\mathbf{R}^q$ .

$C(t) = \|c_{it}(t)\|_{i \in \overline{1, n}, t \in \overline{1, q}}$  – matrix consisting of coefficients of transferring the influence of the risk vector on the products of each species.

$A(t), B(t), C(t)$  – dimensional matrices  $(n \times n)$ ,  $(n \times p)$  i  $(n \times q)$  respectively, which are formed on the basis of preliminary information from the company's reporting documents, available statistical data on the considered process, with the help of experts, economic forecasts and other sources through application methods of data evaluation and solving a separate problem of identifying the values of the parameters of the system being studied.

## 5 Discussion of the Results

Formalization of the model of management of the TI requires *formation of constraints for the process of management of TI*. Introduced above vector of innovative innovation management  $\bar{u}(t) = (u_1(t), u_2(t), \dots, u_p(t))' \in \mathbf{R}^p$  and a vector of risks  $\bar{v}(t) = (v_1(t), v_2(t), \dots, v_q(t))' \in \mathbf{R}^q$  in the system (1) such that each pair must satisfy the following given limit:

$$\begin{aligned}
& (\bar{u}(t), \bar{v}(t)) \in UV(t) = \{(\bar{u}(t), \bar{v}(t)) : \bar{u}(t) \in \mathbf{R}^p, \bar{v}(t) \in \mathbf{R}^q, \\
& S_{\min}(t) \leq \langle B(t)\bar{u}(t) \rangle_n \leq S_{\max}(t), K_{\min}(t) \leq \langle C(t)\bar{v}(t) \rangle_n \leq K_{\max}(t)\}, \quad (2)
\end{aligned}$$

where  $S_{\min}(t) = (S_{\min 1}(t), S_{\min 2}(t), \dots, S_{\min n}(t))' \in \mathbf{R}^n$  – the vector of the minimum acceptable production volume, for which each  $i$ -th coordinate  $S_{\min i}(t)$  is the value of the minimum acceptable volume of production of the  $i$ -th type ( $i \in \overline{1, n}$ ) (for example, the break-even point for each type of product);

$S_{\max}(t) = (S_{\max 1}(t), S_{\max 2}(t), \dots, S_{\max n}(t))' \in \mathbf{R}^n$  – the vector of the upper limit of output, for which each  $i$ -th coordinate is the value of the maximum acceptable output of the  $i$ -th type ( $i \in \overline{1, n}$ ) (for example, the maximum capacity of the market for each product, maximum production capacity, etc.).  $K_{\min}(t) = (K_{\min 1}(t), K_{\min 2}(t), \dots, K_{\min n}(t))'$  and  $K_{\max}(t) = (K_{\max 1}(t), K_{\max 2}(t), \dots, K_{\max n}(t))'$  – vectors of the smallest and largest values of the influence of the risk vector on output of each species [19].

At the same time,  $t \in \overline{0, T-1}$  all the following restrictions must also apply to all:

$$\begin{cases} x_i(t) \geq 0 & (i \in \overline{1, n}), \\ u_j(t) \geq 0 & (j \in \overline{1, p}), \\ v_l(t) \geq 0 & (l \in \overline{1, q}). \end{cases} \quad (3)$$

Note that in the process of controlling technological innovation, the constraints (2) and (3) are a prerequisite that must satisfy the parameters of the system state of generated by the realizations of optimal managerial influences in a discrete dynamic system (1).

In the case if the available statistics on the background of the phase vector  $x$ , the vector of control  $u$  and the risk vector  $v$  are such that the system of linear algebraic equations of the form (1) has an infinite set of solutions, then discrete dynamic models of the form (1) – (3) there will be infinitely a lot. In this case, we form the dependence of the basic unknown values of the system of equations of the form (1) on its free unknowns. Then, substituting arbitrary values of free unknown quantities, we obtain different models from which, based on the introduction of an additional quality criterion, we can form a concrete model suitable for solving this task of TI management.

The obtained results can be applied for the tasks of identifying economic and mathematical models and solving other problems of dynamic optimization of forecasting and data estimation processes taking into account the influence of risks in the conditions of information deficit and uncertainty.

## 6 Conclusions

The author proposed the formalization of the model of TI in the form of a discrete dynamic system. Its dynamic is described by a vector discrete linear recurrence relation

and is subject to the influence of controlled parameters (controls) and an uncontrolled parameter (risk vector or interference).

Such an approach makes it possible to solve the dynamic optimization task of the management of TI. In this case, it is possible to use an algorithm that reduces to the implementation of solutions of systems of linear algebraic equations. This allows to develop efficient numerical procedures that allow one to realize computer simulations of the dynamics of the considered system of the management of TI.

The results presented in the article can be used for economic-mathematical modeling and solving tasks of optimization of the processes of forecasting and management in the condition of lack of information and risk, as well as for developing appropriate software and technological systems to support making effective decisions in practice.

## References

1. Aikhoff, P.: *Fundamentals of Identification of Control Systems*. Mir, Moscow (1975)
2. Grop, D.: *Methods of System Identification*. Mir, Moscow (1979)
3. Sage, E.P., Mels, J.L.: *Identification of Control Systems*. Nauka, Moscow (1974)
4. Ljung, L.: *System Identification: Theory for the user*. Nauka, Moscow (1991)
5. Tsyppkin, Ya. *Fundamentals of the Information Theory of Identification*. Science, Moscow (1984)
6. Reibman, N.: *What is identification?* Science, Moscow (1970)
7. Shteinberg, Sh.: *Identifications in Control Systems*. Energoatomizdat, Moscow (1987)
8. Doehf, R., Visop, R.: *Modern Control Systems*. 13rd ed. Pearson, New Jersey (2013)
9. Teece, D.J.: Business models, business strategy and innovation. *Long Range Planning*, **43**(2-3), 172–194 (2010). doi:10.1016/j.lrp.2009.07.003
10. Rafalski, R.A.: New concept of evaluation of the production assets. *Foundations of Management*, **4**(1), 75-104 (2012). doi:10.2478/fman-2013-0005
11. Kaplan, S. (ed.): *The Business Model Innovation Factory: How to Stay Relevant When the World is Changing*. Wiley, Boston (2015)
12. Oliinyk, V., Kozmenko O., Wiebe I., Kozmenko S.: Optimal control over the process of innovative product diffusion: the case of sony corporation. *Economics and Sociology*, **11**(3), 265–285 (2018). doi:10.14254/2071 789X.2018/11-3/16
13. Martinelli, R.J., Waddell, J.M., Rahschulte, T.J.: *Program Management for Improved Business Results*. Wiley, Boston (2014)
14. Babenko, V., Chebanova, N., Ryzhikova, N., Rudenko, S, Birchenko, N.: Research into the process of multi-level management of enterprise production activities with taking risks into consideration. *Eastern-European Journal of Enterprise Technologies*, **1**(3), 4-12. doi:10.15587/17294061.2018.123461
15. Chorna, M., Nord, G., Avanesova, N., Stoian, O.: Innovative impressionability as a basis for stimulation of agents behavior regarding energy saving. *Academy of Strategic Management Journal*. <https://www.abacademies.org/articles/innovative-impressionability-as-a-basis-for-stimulation-of-agents-behavior-regarding-energy-saving-7554.html> (2018), Accessed 15 March 2019
16. Gontareva, I, Chorna, M., Pawliszczy, D., Barna, M., Dorokhov, O., Osinska, O.: Features of the entrepreneurship development in digital economy. *TEM Journal*, **7**(4), 813-822 (2018)
17. Babenko, V., Romanenkov, Yu., Yakymova, L., Nakisko, A.: Development of the model of minimax adaptive management of innovative processes at an enterprise with consideration of risks. *Eastern-European Journal of Enterprise Technologies*, **5/4**(89), 49-56 (2017). doi:10.15587/1729-4061.2017.112076

18. Babenko, V., Alisejko, E., Kochuyeva, Z.: The task of minimax adaptive management of innovative processes at an enterprise with risk assessment. *Innovative technologies and scientific solutions for industries*, **1**(1), 6-13 (2017). doi:10.30837/2522-9818.2017.1.006
19. Shorikov, A.F., Babenko, V.A.: Optimization of assured result in dynamical model of management of innovation process in the enterprise of agricultural production complex. *Economy of Region*, **1**(37), 196–202 (2014). doi:10.17059/2014-1-18

# Program Logics of Renominative Level with the Composition of Predicate Complement

Mykola Nikitchenko<sup>[0000-0002-4078-1062]</sup>, Oksana Shkilniak<sup>[0000-0003-4139-2525]</sup>,  
Stepan Shkilniak<sup>[0000-0001-8624-5778]</sup>

Taras Shevchenko National University of Kyiv,  
60 Volodymyrska Street, City of Kyiv, Ukraine, 01033  
mykola.nikitchenko@gmail.com, me.oksana@gmail.com,  
sssh@unicyb.kiev.ua

**Abstract.** Program logics are widely used for software verification. Such logics are based on formal program models and reflect main program properties. Among various program logics, Floyd-Hoare logic and its variants take a special place because of its naturalness and simplicity. But such logics are oriented on total pre- and post-conditions, and in the case of partial conditions they become unsound. Different methods to overcome this problem were proposed in our previous works. One of the methods involves extension of program algebras with the composition of predicate complement. This permits to modify rules of the logic making them sound. Such modification requires introduction of undefinedness conditions into logic rules. In this paper we continue our research of such logics. We investigate a special predicate logic called logic of renominative (quantifier-free) level with the composition of predicate complement. This logic is a constituent part of the program logic. We introduce a special consequence relation for this logic, construct a sequent calculus, and prove its soundness and completeness.

**Keywords:** software verification, program logic, Floyd-Hoare logic, partial predicate, soundness, completeness.

## 1 Introduction

The formalism of program logics is the main instrument for software verification [1]. To be effective, such logics should reflect main program properties. Therefore, adequate formal program models should be constructed which will form a base for a program logic. Among such logics we should point to Floyd-Hoare logic and its variants as quite natural and simple [2, 3]. But such logics are oriented on total pre- and post-conditions, and in the case of partial conditions (predicates) they become unsound.

In our previous works [4, 5] we considered several methods to extend Floyd-Hoare logic for partial predicates, in particular, we proposed two methods: 1) introduction of special rule constraints; and 2) restriction of the class of program assertions (of Hoare triples). Both methods make a logic sound but they are difficult for practical usage or



are rather restrictive. Here we study one more method which proposes to extend program algebras with the composition of predicate complement [6, 7]. Introduction of this composition permits to modify rules in such a way that they become sound, but a negative side of this proposal is that logic becomes more complicated. In this case, undefinedness conditions for predicates should be taken into account.

In this paper we continue our research of logics with the composition of predicate complement. We concentrate on a base logic which is a constituent part of program logic. This logic is a special logic of partial quasiary predicates of renominative (quantifier-free) level. We introduce a consequence relation with undefinedness conditions, study its properties, and define a sequent calculus. We prove the soundness and completeness theorems for this logic with the composition of predicate complement.

## 2 Program Algebras with the Composition of Predicate Complement

According to the principles of *composition-nominative approach* [8, 9] we construct program logics based on program algebras. Such algebras are defined in the following way [9, 10]:

- 1) a set  $D$  of *data* processed by programs is defined;
- 2) the classes of *partial predicates*  $Pr = D \xrightarrow{p} Bool$  and *partial functions*  $Fn = D \xrightarrow{p} D$  are defined;
- 3) *operations (compositions)* over  $Pr$  and  $Fn$  are specified.

This scheme leads to *two-sorted program algebras*. In our previous works we considered program algebras with traditional compositions. But the problem of defining sound rules for program logics requires new compositions. Therefore, here we consider a program algebra extended with the *composition of predicate complement*. This unary predicate composition is defined in the following way ( $p \in Pr, d \in D$ ):

$$(\square p)(d) = \begin{cases} T, & \text{if } p(d) \text{ is undefined,} \\ \text{undefined,} & \text{if } p(d) \text{ is defined.} \end{cases}$$

Specifying  $D$  as the class  $D_{CC}(V, A)$  of *hierarchical nominative data* [7, 11] with complex names and values built over the set of basic names  $V$  and the set of basic values  $A$ , we can define a *complemented program algebra* as a two-sorted algebra [7]

$$\begin{aligned} CPAND_{CC}(V, A) &= (Pr_{CC}(V, A), Fn_{CC}(V, A); \\ AS^u, id, IF, WH, S_F^{\bar{u}}, S_P^{\bar{u}}, \Rightarrow v, v \Rightarrow_a, \vee, \neg, \exists x, \square) \end{aligned}$$

where  $Pr_{CC}(V, A)$  and  $Fn_{CC}(V, A)$  are classes of partial predicates and partial function over  $D_{CC}(V, A)$  respectively;  $AS^u, id, IF, WH, S_P^{\bar{u}}, S_F^{\bar{u}}$  are compositions of assignment, identity, conditional, cycle, superposition into predicate, superposition into function respectively;  $\Rightarrow v$  and  $v \Rightarrow_a$  are naming and denaming functions;  $\vee, \neg, \exists x, \square$  are composition of disjunction, negation, existential quantification, and predicate complement;  $v, u, x \in V^+$  are complex names,  $\bar{u} \in \bar{U}$  is a sequence of

complex names. This algebra is quite expressive to present formal semantics of rather complex programs.

A special program logic of Floyd-Hoare type based on such algebras is presented in [7]. Its distinctive feature is introduction of new rules which are sound for partial predicates and which use preconditions constructed with the help of the composition of predicate complement.

For example, a classical rule of Floyd-Hoare logic for sequential execution of operators  $f$  and  $g$  has the form

$$R\_SEQ \frac{\{p\}f\{q\}, \{q\}g\{r\}}{\{p\}f \bullet g\{r\}}$$

where  $f \bullet g$  denotes sequential execution of  $f$  and  $g$ .

This rule is not sound in the case of partial predicates [4]. Therefore, a new sound rule based on extended program algebra was introduced [7]:

$$R\_SSEQ \frac{\{p\}f\{q\}, \{q\}g\{r\}, \{\bar{q}\}g\{r\}}{\{p\}f \bullet g\{r\}}.$$

Obtained program logic can be an important instrument of program verification. So, its thorough investigation is required. This is a rather complicated challenge; therefore, we start with more simple logics. First, we identify a special predicate logic as a constituent part of the program logic. Such predicate logic can be considered as a logic defining constraints (program annotations). Second, we will consider here only logic  $L^{QCR}$  of renominative level which can be characterized as quantifier-free predicate logic of partial quasiary predicates with the composition of predicate complement. The case of first-order logic with quantifiers and functions is planned to study in the forthcoming papers.

### 3 Logic of Partial Quasiary Predicates of Renominative Level with the Composition of Predicate Complement

To define a logic  $L^{QCR}$  we should define [9, 10]

- its class of algebras;
- its language (based on logic signature);
- its class of interpretations;
- its consequence relation;
- its inference relation based on some calculus.

Formal definitions will be given in the next section. We will use the following notations:

- $S \xrightarrow{p} S'$  ( $S \xrightarrow{t} S'$ ) is the class of partial (total) mappings from  $S$  to  $S'$ ;
- $p(d) \downarrow$  ( $p(d) \uparrow$ ) means that  $p$  is defined (undefined) on  $d$ ;
- $p(d) \downarrow = T$  ( $p(d) \downarrow = F$ ) means that  $p$  is defined on  $d$  with value  $T$  ( $F$ ). For this case we also use simpler notation  $p(d) = T$  ( $p(d) = F$ ).

The terms and notations, not defined here, are treated in the sense of [12].

### 3.1 Complemented Algebras of Partial Quasiary Predicates of Renominative Level

Let  $V$  be a set of *names* (*variables*) and  $A$  be a set of *values*. The class  ${}^V A$  of *nominative sets* (*partial assignments*, *partial data*) is defined as the class of all partial mappings from  $V$  to  $A$ , thus,  ${}^V A = V \xrightarrow{p} A$ .

Nominative sets represent *states of program variables*.

The main operation for nominative sets is a total unary parametric *renomination*  $r_{x_1, \dots, x_n}^{v_1, \dots, v_n} : {}^V A \xrightarrow{t} {}^V A$ , where  $v_1, \dots, v_n, x_1, \dots, x_n$  are names, and  $v_1, \dots, v_n$  are distinct [12]. Intuitively, given nominative set  $d$  this operation yields a new nominative set changing the values of  $v_1, \dots, v_n$  to the values of  $x_1, \dots, x_n$  respectively. We also use simpler notation for this renomination:  $r_{\bar{x}}^{\bar{v}}$ . We write  $x \in \bar{v}$  to denote that  $x$  is a variable from  $\bar{v}$ ; we write  $\bar{v} \cup \bar{x}$  to denote the set of variables that occur in the sequences  $\bar{v}$  and  $\bar{x}$ .

The set of *assigned variables* (*names*) in  $d$  is denoted  $asn(d)$ .

Let  $Pr_A^V = {}^V A \xrightarrow{p} Bool$  be the set of all *partial predicates* over  ${}^V A$ . Such predicates are called *partial quasiary predicates*. For a predicate  $p \in Pr_A^V$  its *truth*, *falsity*, and *undefinedness domains* are denoted  $T(p)$ ,  $F(p)$ , and  $\perp(p)$  respectively. Please note that these domains do not intersect pairwise and their union is equal to  ${}^V A$ ; thus, predicate  $p$  is defined by  $T(p)$  and  $F(p)$  only, because  $\perp(p) = {}^V A \setminus (T(p) \cup F(p))$ .

Operations over  $Pr_A^V$  are called *compositions*. Basic compositions of renominative level over quasiary predicates are *disjunction*  $\vee$ , *negation*  $\neg$ , and *renomination*  $R_{\bar{x}}^{\bar{v}}$ .

We extend this set with the composition of *predicate complement*  $\square$ .

These compositions are defined by the following formulas ( $p, q \in Pr_A^V$ ):

- $T(p \vee q) = T(p) \cup T(q)$ ;  $F(p \vee q) = F(p) \cap F(q)$ ;
- $T(\neg p) = F(p)$ ;  $F(\neg p) = T(p)$ ;
- $T(R_{\bar{x}}^{\bar{v}}(p)) = \{d \in {}^V A \mid r_{\bar{x}}^{\bar{v}}(d) \in T(p)\}$ ;  $F(R_{\bar{x}}^{\bar{v}}(p)) = \{d \in {}^V A \mid r_{\bar{x}}^{\bar{v}}(d) \in F(p)\}$ ;
- $T(\square p) = \perp(p)$ ;  $F(\square p) = \emptyset$ .

Please note that definitions of disjunction and negation are similar to *strong Kleene's connectives* [13]. We consider  $\square$  as a composition of propositional level.

A tuple

$$A^{QCR}(V, A) = \langle Pr_A^V; \neg, \vee, R_{\bar{x}}^{\bar{v}}, \square \rangle$$

is called a *complemented algebra of partial quasiary predicates of renominative level*.

A class of such algebras (with different  $A$ ) forms a semantic base for a logic  $L^{QCR}$ .

Now we describe the main properties of  $A^{QCR}(V, A)$ . We do not formulate traditional properties of propositional compositions of disjunction and negation [9, 14], but concentrate on properties of compositions of renomination and complement.

Compositions of disjunction and negation have traditional properties; in contrast to these compositions, the composition of predicate complement is more complicated: it does not have the monotonicity property and it does not have distributivity properties with respect to disjunction. For this composition we identify the following properties.

**Lemma 1.** For any  $p \in Pr_A^V$  we have

$$\Box \neg p = \Box p ; \Box \Box p = \Box p ; \Box \Box \Box p = \Box \Box p .$$

**Lemma 2.** For any  $p \in Pr_A^V$  we have

- 1)  $T(\neg \Box p) = \emptyset ; F(\neg \Box p) = T(\Box p) ; \perp(\neg \Box p) = \perp(\Box p) ;$
- 2)  $T(R_{\bar{x}}^{\bar{v}}(\Box p)) = T(\Box(R_{\bar{x}}^{\bar{v}}(p))) ; F(R_{\bar{x}}^{\bar{v}}(\Box p)) = \emptyset ; \perp(R_{\bar{x}}^{\bar{v}}(\Box p)) = \perp(\Box(R_{\bar{x}}^{\bar{v}}(p))) .$

The notion of unessential variable is important for the composition of renomination. A name (variable)  $z$  is *unessential* for predicate  $p \in Pr_A^V$ , if for any  $d \in {}^V A$  the value of  $p$  does not depends on the value of  $z$  [9, 12].

**Lemma 3.** The following properties of the compositions of renomination and predicate complement hold for any  $p \in Pr_A^V$ :

- $R\vee$ )  $R_{\bar{x}}^{\bar{v}}(p \vee q) = R_{\bar{x}}^{\bar{v}}(p) \vee R_{\bar{x}}^{\bar{v}}(q) ;$
- $R\neg$ )  $R_{\bar{x}}^{\bar{v}}(\neg p) = \neg R_{\bar{x}}^{\bar{v}}(p) ;$
- $RR$ )  $R_{\bar{x}}^{\bar{v}}(R_{\bar{y}}^{\bar{w}}(p)) = R_{\bar{x}}^{\bar{v}} \circ_{\bar{y}}^{\bar{w}}(p) ;$
- $R\Box$ )  $R_{\bar{x}}^{\bar{v}}(\Box p) = \Box R_{\bar{x}}^{\bar{v}}(p) ;$
- $R$ )  $R(p) = p ;$
- $RI$ )  $R_{z,\bar{x}}^{z,\bar{v}}(p) = R_{\bar{x}}^{\bar{v}}(p) ;$
- $RU$ )  $R_{y,\bar{x}}^{z,\bar{v}}(p) = R_{\bar{x}}^{\bar{v}}(p)$  if  $z \in V$  is unessential for  $p$ .

### 3.2 Language (signature and formulas) of $L^{QCR}$

Let  $Ps$  be a set of *predicate symbols*,  $V$  be an infinite set of *names (variables)*. Usually, within  $V$  a subset  $U$  of *unessential variables* is identified but here we will not go into detail [12]. A tuple

$$\Sigma^{QCR} = (V, U; \vee, \neg, R_{\bar{x}}^{\bar{v}}, \Box; Ps)$$

is called the *language signature*.

For simplicity, we use the same notation for symbols of compositions and compositions themselves.

Given  $\Sigma^{QCR}$ , we define inductively the *language* of  $L^{QCR}$  – the *set of formulas* denoted  $Fr(L^{QCR})$  or simply  $Fr$ :

- if  $P \in Ps$  then  $P \in Fr$ . Formulas of such forms are called *atomic*;
- if  $\Phi, \Psi \in Fr$  then  $\Phi \vee \Psi, \neg \Phi, R_{\bar{x}}^{\bar{v}} \Phi, \Box \Phi \in Fr$ .

### 3.3 $L^{QCR}$ -interpretations

Let  $A^{QCR}(V, A) = \langle Pr_A^V; \neg, \vee, R_{\bar{x}}^{\bar{v}}, \square \rangle$  be a complemented algebra of a signature  $\Sigma^{QCR} = (V, U; \vee, \neg, R_{\bar{x}}^{\bar{v}}, \square; Ps)$ ,  $I_Q^{Ps} = Ps \xrightarrow{t} Pr_A^V$  be an *interpretation mapping of predicate symbols*. Then a tuple  $J(\Sigma^{QCR}) = (A^{QCR}(V, A), I_Q^{Ps})$  is called an  $L^{QCR}$ -*interpretation*.

We simplify notation for  $L^{QCR}$ -interpretation  $J(\Sigma^{QCR})$  omitting  $L^{QCR}$  and  $\Sigma^{QCR}$ .

In interpretation  $J$ , an algebra  $A^{QCR}(V, A)$  defines interpretations of composition symbols while  $I_Q^{Ps}$  defines interpretations of predicate symbols.

For given interpretation  $J$  and formula  $\Phi$ , we can define by induction on the structure of  $\Phi$  its value in  $J$ . Obtained predicate is denoted  $\Phi_J$ .

**Lemma 4.** Let  $J$  be an interpretation and  $\Phi, \Psi \in Fr$ . Then

$$\begin{aligned} R) & R(\Phi)_J = \Phi_J; \\ RI) & R_{z, \bar{x}}^{z, \bar{v}}(\Phi)_J = R_{\bar{x}}^{\bar{v}}(\Phi)_J; \\ RU) & R_{y, \bar{x}}^{z, \bar{v}}(\Phi)_J = R_{\bar{x}}^{\bar{v}}(\Phi)_J \text{ if } z \in V \text{ is unessential for } \Phi; \\ R\neg) & R_{\bar{x}}^{\bar{v}}(\neg\Phi)_J = \neg R_{\bar{x}}^{\bar{v}}(\Phi)_J; \\ R\vee) & R_{\bar{x}}^{\bar{v}}(\Phi \vee \Psi)_J = R_{\bar{x}}^{\bar{v}}(\Phi)_J \vee R_{\bar{x}}^{\bar{v}}(\Psi)_J; \\ RR) & R_{\bar{x}}^{\bar{v}}(R_{\bar{y}}^{\bar{w}}(\Phi))_J = R_{\bar{x}}^{\bar{v}} \circ_{\bar{y}}^{\bar{w}}(\Phi)_J; \\ R\square) & R_{\bar{x}}^{\bar{v}}(\square\Phi)_J = \square R_{\bar{x}}^{\bar{v}}(\Phi)_J. \end{aligned}$$

### 3.4 Logical Consequence Relation under Conditions of Undefinedness

Introduction of composition  $\square$  requires more complicated consequence relation because undefinedness domains should be taken into consideration. Here we introduce new consequence relation between sets of formulas denoted  $|\models_{IR}^\perp$  which generalizes irrefutability relation  $|\models_{IR}$  [7].

Let  $\Sigma \subseteq Fr$  and  $J$  be an interpretation.

We denote:

$$\bigcap_{\Phi \in \Sigma} T(\Phi_J) \text{ as } T^\wedge(\Sigma_J), \bigcap_{\Phi \in \Sigma} F(\Phi_J) \text{ as } F^\wedge(\Sigma_J), \bigcap_{\Phi \in \Sigma} \perp(\Phi_J) \text{ as } \perp^\wedge(\Sigma_J).$$

Here  $\Sigma_J$  denotes set  $\{\Phi_J \mid \Phi \in \Sigma\}$ .

Set  $\Sigma$  can be empty. In this case

$$T^\wedge(\Sigma) = T^\wedge(\emptyset) = F^\wedge(\Sigma) = F^\wedge(\emptyset) = \perp^\wedge(\Sigma) = \perp^\wedge(\emptyset) = {}^V A.$$

Let  $\Gamma, U, \Delta \subseteq Fr$ . Informally, the statement “ $\Delta$  is irrefutable consequence of  $\Gamma$  under undefinedness conditions  $U$  in interpretation  $J$ ” means

“for any  $d \in {}^V A$  if  $\varphi_J(d) \uparrow$  for any  $\varphi \in U$  then it is not possible that  $(\xi_J(d) = T$  for any  $\xi \in \Gamma$  and  $\psi_J(d) = F$  for any  $\psi \in \Delta$ )”.

This statement is equivalent to the following statement:

“for any  $d \in {}^V A$  if  $d \in \perp^\wedge(U_J)$  then it is not possible that  $d \in T^\wedge(\Gamma_J) \cap F^\wedge(\Delta_J)$ ”.

The former statement can be reformulated as follows:

“for any  $d \in {}^V A$  it is not possible that  $(d \in \perp^\wedge(U_J))$  and  $d \in T^\wedge(\Gamma_J) \cap F^\wedge(\Delta_J)$ ”.

Finally, we obtain the following statement:

$$\perp^\wedge(U_J) \cap T^\wedge(\Gamma_J) \cap F^\wedge(\Delta_J) = \emptyset.$$

So, we come to the following formal definition:  $\Delta$  is *irrefutable consequence* of  $\Gamma$  under undefinedness conditions  $U$  in interpretation  $J$  (denoted  $U / \Gamma_J \models_{IR}^\perp \Delta$ ) if

$$T^\wedge(\Gamma_J) \cap \perp^\wedge(U_J) \cap F^\wedge(\Delta_J) = \emptyset.$$

In particular, for  $U = \emptyset$  we obtain *irrefutability consequence relation*  $\Gamma_J \models_{IR} \Delta$ .

$\Delta$  is *logical irrefutability consequence* of  $\Gamma$  under undefinedness conditions  $U$  (denoted  $U / \Gamma \models_{IR}^\perp \Delta$ ), if  $U / \Gamma_J \models_{IR}^\perp \Delta$  for any interpretation  $J$ .

In particular, for  $U = \emptyset$ , we get traditional *logical irrefutability relation*  $\Gamma \models_{IR} \Delta$ .

Let us now describe the main properties of the consequence relation  $\models_{IR}^\perp$  for propositional level.

By definition of  $\models_{IR}^\perp$ , we obtain *monotonicity*:

M) Let  $\Gamma \subseteq \Lambda$ ,  $U \subseteq W$ , and  $\Delta \subseteq \Sigma$ ; then  $U / \Gamma \models_{IR}^\perp \Delta \Rightarrow W / \Lambda \models_{IR}^\perp \Sigma$ .

The following properties describe conditions under which  $\models_{IR}^\perp$  holds.

**Theorem 1.** For any  $U, \Gamma, \Delta \subseteq Fr$ ,  $\Phi \in Fr$ :

- C)  $U / \Phi, \Gamma \models_{IR}^\perp \Delta, \Phi$ ;
- $C_{UL}$ )  $U, \Phi / \Phi, \Gamma \models_{IR}^\perp \Delta$ ;
- $C_{UR}$ )  $U, \Phi / \Gamma \models_{IR}^\perp \Delta, \Phi$ ;
- $C_{\square}$ )  $U / \Gamma \models_{IR}^\perp \Delta, \square \Phi \square$ .

*Proof.* Property C holds because  $T(\Phi_J) \cap F(\Phi_J) = \emptyset$ .

For property  $C_{UL}$  we take into consideration that  $\perp(\Phi_J) \cap T(\Phi_J) = \emptyset$ .

For property  $C_{UR}$  we take into consideration that  $\perp(\Phi_J) \cap F(\Phi_J) = \emptyset$ .

Property  $C_{\square}$  holds because  $F(\square \Phi \square) = \emptyset$ .

For  $\models_{IR}^\perp$  the following properties of formula decomposition hold.

**Theorem 2.** For any  $U, \Gamma, \Delta \subseteq Fr$ ,  $\Phi, \Psi, \Theta \in Fr$ :

- $\neg_L$ )  $U / \neg \Phi, \Gamma \models_{IR}^\perp \Delta \Leftrightarrow U / \Gamma \models_{IR}^\perp \Delta, \Phi$ ;
- $\neg_R$ )  $U / \Gamma \models_{IR}^\perp \Delta, \neg \Phi \Leftrightarrow U / \Phi, \Gamma \models_{IR}^\perp \Delta$ ;
- $\vee_L$ )  $U / \Phi \vee \Psi, \Gamma \models_{IR}^\perp \Delta \Leftrightarrow U / \Phi, \Gamma \models_{IR}^\perp \Delta$  and  $U / \Psi, \Gamma \models_{IR}^\perp \Delta$ ;
- $\vee_R$ )  $U / \Gamma \models_{IR}^\perp \Delta, \Phi \vee \Psi \Leftrightarrow U / \Gamma \models_{IR}^\perp \Delta, \Phi, \Psi$ ;
- $\neg_U$ )  $U, \neg \Theta / \Gamma \models_{IR}^\perp \Delta \Leftrightarrow U, \Theta / \Gamma \models_{IR}^\perp \Delta$ ;
- $\vee_U$ )  $U, \Phi \vee \Theta / \Gamma \models_{IR}^\perp \Delta \Leftrightarrow U, \Phi, \Theta / \Gamma \models_{IR}^\perp \Delta$  and  $U, \Phi / \Gamma \models_{IR}^\perp \Theta, \Delta$  and  $U, \Theta / \Gamma \models_{IR}^\perp \Phi, \Delta$ ;
- $\square_U$ )  $U, \square \Phi \square / \Gamma \models_{IR}^\perp \Delta \Leftrightarrow U / \Phi, \Gamma \models_{IR}^\perp \Delta$  and  $U / \Gamma \models_{IR}^\perp \Delta, \Phi$ ;
- $\square_L$ )  $U / \square \Phi, \Gamma \models_{IR}^\perp \Delta \Leftrightarrow U, \Phi / \Gamma \models_{IR}^\perp \Delta$ .

*Proof.* Property  $\neg_U$  holds because  $\perp(\neg \Phi_J) = \perp(\Phi_J)$ .

Property  $\vee_U$  holds because

$$\perp(\Phi_J \vee \Psi_J) = (\perp(\Phi_J) \wedge \perp(\Psi_J)) \cup (\perp(\Phi_J) \wedge F(\Psi_J)) \cup (F(\Phi_J) \wedge \perp(\Psi_J)).$$

Property  $\Box_U$  holds because  $\perp(\Box\Phi_J) \equiv T(\Phi_J) \cup F(\Phi_J)$ .

Properties  $\neg_L, \neg_R, \vee_L, \vee_R$  are similar to properties of  $\models_{IR}$  [9, 12, 13]. Properties  $\neg_U, \vee_U, \Box_L, \Box_U$  are special for  $L^{QCR}$ .

Let us consider properties of relation  $\models_{IR}^U$  of a renominative level. Their proofs are based on Theorem 2. Each of properties  $R, RI, RU, RR, R\neg, R\vee, R\Box$  of Lemma 4 induces three corresponding properties for  $\models_{IR}^U$ , depending on the position of a formula (in the left side of  $\models_{IR}^U$ , in the right side of  $\models_{IR}^U$ , in the undefinedness conditions of  $\models_{IR}^U$ ). Such properties are formulated in a similar way, for example, the following properties  $R\Box_L, R\Box_R, R\Box_U$  are induced by  $R\Box$ :

$$R\Box_L) U / R_x^{\bar{\vee}}(\Box\Phi), \Gamma \models_{IR}^{\perp} \Delta \Leftrightarrow U / \Box R_x^{\bar{\vee}}(\Phi), \Gamma \models_{IR}^{\perp} \Delta;$$

$$R\Box_R) U / \Gamma \models_{IR}^{\perp} \Delta, R_x^{\bar{\vee}}(\Box\Phi) \Leftrightarrow U / \Gamma \models_{IR}^{\perp} \Delta, \Box R_x^{\bar{\vee}}(\Phi);$$

$$R\Box_U) U, R_x^{\bar{\vee}}(\Box\Phi) / \Gamma \models_{IR}^{\perp} \Delta \Leftrightarrow U, \Box R_x^{\bar{\vee}}(\Phi) / \Gamma \models_{IR}^{\perp} \Delta.$$

#### 4 Sequent Calculus for $L^{QCR}$

Usually, inference relations are defined by some axiomatic systems (calculi). We present here a system that formalizes logical consequence relation between two sets of formulas. Such systems are called *sequent calculi*.

We construct a sequent calculus  $C^{QCR}$  for relation  $\models_{IR}^{\perp}$ .

The main objects of this calculus are *sequents*. Here we consider only the case with *finite* sequents. We construct calculus in the style of semantic tableau, so, we will treat sequents as finite sets of formulas signed (marked, indexed) by symbols  $\vdash, \dashv$ , and  $\perp$ .

Formulas from  $\Gamma$  (they are signed by  $\vdash$ ) are called *T-formulas*, formulas from  $\Delta$  (they are signed by  $\dashv$ ) are called *F-formulas*, and formulas from  $U$  (they are signed by  $\perp$ ) are called  *$\perp$ -formulas*.

Sequents are denoted  $\vdash\Gamma\perp U\dashv\Delta$ , in abbreviated form  $\Sigma$ .

The *derivation* in a sequent calculus has the form of a tree whose vertices are sequents. Such trees are called *sequent trees*.

The rules of sequent calculus are called *sequent forms*. They are syntactical analogs of the semantic properties of the corresponding relations of logical consequence. Details of the definition of *sequent tree* can be found in [12].

*Closed sequents* are axioms of the sequent calculus.

A *closed sequent* is specified in such a way that the following condition should hold:

$$\text{if sequent } \vdash\Gamma\perp U\dashv\Delta \text{ is closed then } U / \Gamma \models_{IR}^{\perp} \Delta.$$

Sequent calculus is defined by basic sequent forms and closure conditions of sequents.

For  $C^{QCR}$  we take the following closure conditions:

sequent  $\vdash \Gamma \perp U \perp \Delta$  is closed if condition  $C \vee C_{UL} \vee C_{UR} \vee C_{\square}$  holds.

Here  $C, C_{UL}, C_{UR}, C_{\square}$  are the following basic closure conditions:

- $C$ ) exists  $\Phi$ :  $\Phi \in \Gamma$  and  $\Phi \in \Delta$ ;
- $C_{UL}$ ) exists  $\Phi$ :  $\Phi \in \Gamma$  and  $\Phi \in U$ ;
- $C_{UR}$ ) exists  $\Phi$ :  $\Phi \in \Delta$  and  $\Phi \in U$ ;
- $C_{\square}$ ) exists  $\Phi$ :  $\square \Phi \in \Delta$ .

**Theorem 3.** If sequent  $\vdash \Gamma \perp U \perp \Delta$  is closed then  $U/\Gamma \models_{IR}^{\perp} \Delta$ .

*Proof.* The theorem statement follows directly from Theorem 1.

The sequent forms of decomposition of compositions  $\vee, \neg, \square$  are induced by the corresponding properties of formulas decomposition, in particular, basic sequent forms of  $C^{QCR}$  calculus are induced by the formula decomposition properties  $\neg_L, \neg_R, \vee_L, \vee_R, \neg U, \vee U, \square U, \square L$ :

$$\begin{array}{l} \vdash \neg \frac{\neg \Phi, \Sigma}{\neg \neg \Phi, \Sigma}; \quad \neg \neg \frac{\vdash \Phi, \Sigma}{\neg \neg \Phi, \Sigma}; \quad \perp \neg \frac{\perp \Phi, \Sigma}{\perp \neg \Phi, \Sigma}; \\ \vdash \vee \frac{\vdash \Phi, \Sigma \quad \vdash \Psi, \Sigma}{\vdash \Phi \vee \Psi, \Sigma}; \quad \neg \vee \frac{\neg \Phi, \neg \Psi, \Sigma}{\neg \Phi \vee \Psi, \Sigma}; \quad \perp \vee \frac{\perp \Phi, \perp \Psi, \Sigma \quad \perp \Phi, \neg \Psi, \Sigma \quad \neg \Phi, \perp \Psi, \Sigma}{\perp \Phi \vee \Psi, \Sigma}; \\ \perp \square \frac{\vdash \Phi, \Sigma \quad \neg \Phi, \Sigma}{\perp \square \Phi, \Sigma}; \quad \vdash \square \frac{\perp \Phi, \Sigma}{\vdash \square \Phi, \Sigma}. \end{array}$$

For the composition of renomination we use the following forms of equivalent transformations:

$$\begin{array}{l} \vdash R \neg \frac{\vdash \neg R_x^{\bar{v}}(\Phi), \Sigma}{\vdash R_x^{\bar{v}}(\neg \Phi), \Sigma}; \quad \neg R \neg \frac{\neg \neg R_x^{\bar{v}}(\Phi), \Sigma}{\neg R_x^{\bar{v}}(\neg \Phi), \Sigma}; \quad \perp R \neg \frac{\perp \neg R_x^{\bar{v}}(\Phi), \Sigma}{\perp R_x^{\bar{v}}(\neg \Phi), \Sigma}; \\ \vdash R \vee \frac{\vdash R_x^{\bar{v}}(\Phi) \vee R_x^{\bar{v}}(\Psi), \Sigma}{\vdash R_x^{\bar{v}}(\Phi \vee \Psi), \Sigma}; \quad \neg R \vee \frac{\neg R_x^{\bar{v}}(\Phi) \vee R_x^{\bar{v}}(\Psi), \Sigma}{\neg R_x^{\bar{v}}(\Phi \vee \Psi), \Sigma}; \quad \perp R \vee \frac{\perp R_x^{\bar{v}}(\Phi) \vee R_x^{\bar{v}}(\Psi), \Sigma}{\perp R_x^{\bar{v}}(\Phi \vee \Psi), \Sigma}; \\ \vdash R \square \frac{\vdash \square R_x^{\bar{v}}(\Phi), \Sigma}{\vdash R_x^{\bar{v}}(\square \Phi), \Sigma}; \quad \neg R \square \frac{\neg \square R_x^{\bar{v}}(\Phi), \Sigma}{\neg R_x^{\bar{v}}(\square \Phi), \Sigma}; \quad \perp R \square \frac{\perp \square R_x^{\bar{v}}(\Phi), \Sigma}{\perp R_x^{\bar{v}}(\square \Phi), \Sigma}; \\ \vdash RR \frac{\vdash R_x^{\bar{v}} \circ_y^{\bar{w}}(\Phi), \Sigma}{\vdash R_x^{\bar{v}}(R_y^{\bar{w}}(\Phi)), \Sigma}; \quad \neg RR \frac{\neg R_x^{\bar{v}} \circ_y^{\bar{w}}(\Phi), \Sigma}{\neg R_x^{\bar{v}}(R_y^{\bar{w}}(\Phi)), \Sigma}; \quad \perp RR \frac{\perp R_x^{\bar{v}} \circ_y^{\bar{w}}(\Phi), \Sigma}{\perp R_x^{\bar{v}}(R_y^{\bar{w}}(\Phi)), \Sigma}. \end{array}$$

Here  $R_x^{\bar{v}} \circ_y^{\bar{w}}(\Phi)$  represents application of two successive renominations  $R_x^{\bar{v}}(R_y^{\bar{w}}(\Phi))$  [12].

Forms of simplification:

$$\vdash R \frac{\vdash \Phi, \Sigma}{\vdash R(\Phi), \Sigma}; \quad \neg R \frac{\neg \Phi, \Sigma}{\neg R(\Phi), \Sigma}; \quad \perp R \frac{\perp \Phi, \Sigma}{\perp R(\Phi), \Sigma};$$



$$\begin{array}{ccc}
\vdash_{\text{RI}} \frac{\vdash R_{\bar{x}}^{\bar{v}}(\Phi), \Sigma}{\vdash R_{z, \bar{x}}^{z, \bar{v}}(\Phi), \Sigma}; & \vdash_{\text{RI}} \frac{\neg R_{\bar{x}}^{\bar{v}}(\Phi), \Sigma}{\neg R_{z, \bar{x}}^{z, \bar{v}}(\Phi), \Sigma}; & \perp_{\text{RI}} \frac{\perp R_{\bar{x}}^{\bar{v}}(\Phi), \Sigma}{\perp R_{z, \bar{x}}^{z, \bar{v}}(\Phi), \Sigma}; \\
\vdash_{\text{RU}} \frac{\vdash R_{\bar{u}}^{\bar{v}}(\Phi), \Sigma}{\vdash R_{z, \bar{u}}^{y, \bar{v}}(\Phi), \Sigma}; & \vdash_{\text{RU}} \frac{\neg R_{\bar{u}}^{\bar{v}}(\Phi), \Sigma}{\neg R_{z, \bar{u}}^{y, \bar{v}}(\Phi), \Sigma}; & \perp_{\text{RU}} \frac{\perp R_{\bar{x}}^{\bar{v}}(\Phi), \Sigma}{\perp R_{y, \bar{x}}^{z, \bar{v}}(\Phi), \Sigma}.
\end{array}$$

The names of the sequent forms are consistent with the names of the properties of the decomposition of the formulas. Introduction of undefinedness formulas additionally leads to new sequent forms with three premises (rule  $\perp\vee$ ).

For basic rules of  $C^{QCR}$  we have the following main properties.

**Theorem 4.**

1. Let  $\frac{\vdash \Lambda_{\perp} W_{\perp} K}{\vdash \Gamma_{\perp} U_{\perp} \Delta}$  be basic sequent form. Then
  - a)  $U / \Gamma \models_{IR}^{\perp} \Delta \Leftrightarrow W / \Lambda \models_{IR}^{\perp} K$ ;
  - b)  $U / \Gamma \not\models_{IR}^{\perp} \Delta \Leftrightarrow W / \Lambda \not\models_{IR}^{\perp} K$ .
2. Let  $\frac{\vdash \Lambda_{\perp} W_{\perp} K \quad \vdash X_{\perp} V_{\perp} Z}{\vdash \Gamma_{\perp} U_{\perp} \Delta}$  be basic sequent form. Then
  - a)  $U / \Gamma \models_{IR}^{\perp} \Delta \Leftrightarrow W / \Lambda \models_{IR}^{\perp} K$  and  $V / X \models_{IR}^{\perp} Z$ ;
  - b)  $U / \Gamma \not\models_{IR}^{\perp} \Delta \Leftrightarrow W / \Lambda \not\models_{IR}^{\perp} K$  or  $V / X \not\models_{IR}^{\perp} Z$ .
3. Let  $\frac{\vdash \Lambda_{\perp} W_{\perp} K \quad \vdash X_{\perp} V_{\perp} Z \quad \vdash M_{\perp} Y_{\perp} N}{\vdash \Gamma_{\perp} U_{\perp} \Delta}$  be basic sequent form. Then
  - a)  $U / \Gamma \models_{IR}^{\perp} \Delta \Leftrightarrow W / \Lambda \models_{IR}^{\perp} K$  and  $V / X \models_{IR}^{\perp} Z$  and  $Y / M \models_{IR}^{\perp} N$ ;
  - b)  $U / \Gamma \not\models_{IR}^{\perp} \Delta \Leftrightarrow W / \Lambda \not\models_{IR}^{\perp} K$  or  $V / X \not\models_{IR}^{\perp} Z$  or  $Y / M \not\models_{IR}^{\perp} N$ .

*Proof.* The proof of the theorem is obtained by set-theoretic methods using a formula specifying relation  $\models_{IR}^{\perp}$ .

## 5 Soundness and Completeness of $C^{QCR}$

Now we prove soundness and completeness theorems for  $C^{QCR}$ .

**Theorem 5 (soundness).** Let sequent  $\vdash \Gamma_{\perp} U_{\perp} \Delta$  be derivable in  $C^{QCR}$ . Then  $U / \Gamma \models_{IR}^{\perp} \Delta$ .

*Proof.* If  $\vdash \Gamma_{\perp} U_{\perp} \Delta$  is derivable then a finite closed tree was constructed. From this follows that for any leaf of this tree its sequent  $\vdash \Lambda_{\perp} W_{\perp} K$  is closed. Thus, by Theorem 4,  $W / \Lambda \models_{IR}^{\perp} K$  holds. Therefore, for the root of the tree (sequent  $\vdash \Gamma_{\perp} U_{\perp} \Delta$ ) we have that  $U / \Gamma \models_{IR}^{\perp} \Delta$  holds.

The completeness is traditionally proved on the basis of theorems of the existence of a counter-model for the set of formulas of a non-closed path in the sequent tree. In this case a method of *model sets* is used.

We apply this method to the  $C^{QCR}$  calculus.

Set  $H$  of signed formulas is a *model set* (*Hintikka's set*) for  $L^{QCR}$  if the following conditions hold:

*Decomposition conditions:*

$HC_U$ ) For any  $\Phi \in Fr$  at most one of  $\vdash \Phi$ ,  $\neg \Phi$ ,  $\perp \Phi$  can belong to  $H$ ;

$HC_{\Box}$ ) For any  $\Phi \in Fr$  it is not possible that  $\neg \Box \Phi \in H$ ;

$H_{\neg L}$ ) If  $\vdash \neg \Phi \in H$ , then  $\neg \Phi \in H$ ;

$H_{\neg R}$ ) If  $\neg \neg \Phi \in H$ , then  $\vdash \Phi \in H$ ;

$H_{\vee L}$ ) If  $\vdash \Phi \vee \Psi \in H$ , then  $\vdash \Phi \in H$  or  $\vdash \Psi \in H$ ;

$H_{\vee R}$ ) If  $\neg \Phi \vee \Psi \in H$ , then  $\neg \Phi \in H$  and  $\neg \Psi \in H$ ;

$H_{\neg U}$ ) If  $\perp \neg \Phi \in H$ , then  $\perp \Phi \in H$ ;

$H_{\vee U}$ ) If  $\perp \Phi \vee \vartheta \in H$ , then  $\perp \Phi \in H$  and  $\perp \vartheta \in H$

or  $\perp \Phi \in H$  and  $\neg \vartheta \in H$  or  $\neg \Phi \in H$  and  $\perp \vartheta \in H$ ;

$H_{\Box L}$ ) If  $\vdash \Box \Phi \in H$ , then  $\perp \Phi \in H$ ;

$H_{\Box U}$ ) If  $\perp \Box \Phi \in H$ , then  $\vdash \Phi \in H$  or  $\neg \Phi \in H$ .

*Conditions for the composition of renomination* are formulated in a similar way, for example, sequent forms  $RI$  and  $R\Box$  induce the following conditions:

$HRI_L$ )  $\vdash R_{z,\bar{x}}^{\exists,\forall}(\Phi) \in H \Rightarrow \vdash R_{\bar{x}}^{\forall}(\Phi) \in H$ ;

$HRI_R$ )  $\neg R_{z,\bar{x}}^{\exists,\forall}(\Phi) \in H \Rightarrow \neg R_{\bar{x}}^{\forall}(\Phi) \in H$ ;

$HRI_U$ )  $\perp R_{z,\bar{x}}^{\exists,\forall}(\Phi) \in H \Rightarrow \perp R_{\bar{x}}^{\forall}(\Phi) \in H$ ;

$HR_{\Box L}$ )  $\vdash R_{\bar{x}}^{\forall}(\Box \Phi) \in H \Rightarrow \vdash \Box R_{\bar{x}}^{\forall}(\Phi) \in H$ ;

$HR_{\Box R}$ )  $\neg R_{\bar{x}}^{\forall}(\Box \Phi) \in H \Rightarrow \neg \Box R_{\bar{x}}^{\forall}(\Phi) \in H$ ;

$HR_{\Box U}$ )  $\perp R_{\bar{x}}^{\forall}(\Box \Phi) \in H \Rightarrow \perp \Box R_{\bar{x}}^{\forall}(\Phi) \in H$ .

In the same way conditions  $HR_L$ ,  $HR_R$ ,  $HR_U$ ,  $HRU_L$ ,  $HRU_R$ ,  $HRU_U$ ,  $HRR_L$ ,  $HRR_R$ ,  $HRR_U$ ,  $HR_{\neg L}$ ,  $HR_{\neg R}$ ,  $HR_{\neg U}$ ,  $HR_{\vee L}$ ,  $HR_{\vee R}$ ,  $HR_{\vee}$  can be formulated.

A set  $H \subseteq Fr$  is called *satisfiable* if there exist a set  $A$ , an interpretation  $J$ , and a nominative set  $\delta \in {}^V A$  such that

- $\vdash \Phi \in H \Rightarrow \Phi_A(\delta) \downarrow = T$ ;
- $\neg \Phi \in H \Rightarrow \Phi_A(\delta) \downarrow = F$ ;
- $\perp \Phi \in H \Rightarrow \Phi_A(\delta) \uparrow$ .

A set  $H$  of signed formulas for which the above-written conditions hold is called  $H^{QCR}$ -model.

**Theorem 6.** Let  $H$  be  $H^{QCR}$ -model for  $L^{QCR}$ . Then  $H$  is satisfiable.

*Proof.* Given  $H^{QCR}$ -model  $H$ , we should construct a set  $A$ , an interpretation  $J$ , and a nominative set  $\delta \in {}^V A$  that demonstrate satisfiability of  $H$ . These constructions are rather complicated due to undefinedness conditions therefore here we do not present the proof in all details but demonstrate only its main parts.

Let  $W = nm(H)$  be a set of subject names (variables) that occur in  $H$ . Let a set  $A$  duplicates  $W$  and  $\delta \in {}^V A$  be a nominative set such that  $asn(\delta) = W$ .

Let us prescribe values of basic predicates on nominative set  $\delta$  and nominative sets of the form  $r_{\bar{x}}^{\bar{v}}(\delta)$ . To do this, we use notations  $P_A(\delta) = T$ ,  $P_A(\delta) = F$ , and  $P_A(\delta) \uparrow$  to prescribe the value of  $P$  on  $d$  in algebra  $A^{QCR}(V, A)$  equal to  $T$ , equal to  $F$ , and to be undefined respectively:

- $\vdash P \in H \Rightarrow P_A(\delta) = T$ ;
- $\neg \vdash P \in H \Rightarrow P_A(\delta) = F$ ;
- $\perp \vdash P \in H \Rightarrow P_A(\delta) \uparrow$ ;
- $\vdash R_{\bar{x}}^{\bar{v}}(P) \in H \Rightarrow P_A(r_{\bar{x}}^{\bar{v}}(\delta)) = T$ ;
- $\neg \vdash R_{\bar{x}}^{\bar{v}}(P) \in H \Rightarrow P_A(r_{\bar{x}}^{\bar{v}}(\delta)) = F$ ;
- $\perp \vdash R_{\bar{x}}^{\bar{v}}(P) \in H \Rightarrow P_A(r_{\bar{x}}^{\bar{v}}(\delta)) \uparrow$ .
- Formulas of the form  $\vdash R_{\bar{x}}^{\bar{v}}(P)$  are called *primitive*.

For a predicate symbol  $P \in Ps$  that does not occur in  $H$ , its value can be chosen in arbitrary way. Also, we should treat variables from  $U$  as unessential.

For atomic and primitive formulas the satisfiability statements follow from their definitions.

Now the proof goes on by induction on the formula structure.

Let us prove the theorem for conditions  $HRI_L$ ,  $HR\Box_R$ ,  $HR\Box_U$ ,  $H\neg_L$ ,  $H\neg_R$ ,  $H\neg_U$ ,  $H\vee_L$ ,  $H\vee_R$ ,  $H\vee_U$ ,  $H\Box_U$ ,  $H\Box_L$ .

Let  $\vdash R_{z, \bar{x}}^{z, \bar{v}}(\Phi) \in H$ . By  $HRI_L$  we have  $\vdash R_{\bar{x}}^{\bar{v}}(\Phi) \in H$ . By induction hypothesis  $R_{\bar{x}}^{\bar{v}}(\Phi)_A(\delta) = T$ , therefore  $R_{z, \bar{x}}^{z, \bar{v}}(\Phi)_A(\delta) = T$ .

Let  $\neg \vdash R_{\bar{x}}^{\bar{v}}(\Box \Phi) \in H$ . By  $HR\Box_R$  we have  $\neg \vdash \Box R_{\bar{x}}^{\bar{v}}(\Phi) \in H$ . By induction hypothesis  $\Box R_{\bar{x}}^{\bar{v}}(\Phi)_A(\delta) = F$ , therefore  $R_{\bar{x}}^{\bar{v}}(\Box \Phi)_A(\delta) = F$ .

Let  $\perp \vdash R_{\bar{x}}^{\bar{v}}(\Box \Phi) \in H$ . By  $HR\Box_U$  we have  $\perp \vdash \Box R_{\bar{x}}^{\bar{v}}(\Phi) \in H$ . By induction hypothesis  $\Box R_{\bar{x}}^{\bar{v}}(\Phi)_A(\delta) \uparrow$ , therefore  $R_{\bar{x}}^{\bar{v}}(\Box \Phi)_A(\delta) \uparrow$ .

Let  $\vdash \neg \Phi \in H$ . By  $H\neg_L$  we have  $\neg \vdash \Phi \in H$ . By induction hypothesis  $\Phi_A(\delta) = F$ , therefore  $\neg \Phi_A(\delta) = T$ .

Let  $\neg \vdash \neg \Phi \in H$ . By  $H\neg_R$  we have  $\vdash \Phi \in H$ . By induction hypothesis  $\Phi_A(\delta) = T$ , therefore  $\neg \Phi_A(\delta) = F$ .

Let  $\vdash \Phi \vee \Psi \in H$ . By  $H\vee_L$  we have  $\vdash \Phi \in H$  or  $\vdash \Psi \in H$ . By induction hypothesis  $\Phi_A(\delta) = T$  and  $\Psi_A(\delta) = T$ , therefore  $(\Phi \vee \Psi)_A(\delta) = T$ .

Let  $\neg \vdash \Phi \vee \Psi \in H$ . By  $H\vee_R$  we have  $\neg \vdash \Phi \in H$  and  $\neg \vdash \Psi \in H$ . By induction hypothesis  $\Phi_A(\delta) = F$  and  $\Psi_A(\delta) = F$ , therefore  $(\Phi \vee \Psi)_A(\delta) = F$ .

Let  $\perp \vdash \neg \Phi \in H$ . By  $H\neg_U$  we have  $\perp \vdash \Phi \in H$ . By induction hypothesis  $\Phi_A(\delta) \uparrow$ , therefore  $\neg \Phi_A(\delta) \uparrow$ .

Let  $\perp \vdash \Phi \vee \vartheta \in H$ . By  $H\vee_U$   $\perp \vdash \Phi \in H$  and  $\perp \vdash \vartheta \in H$  or  $\perp \vdash \Phi \in H$  and  $\neg \vdash \vartheta \in H$  or  $\neg \vdash \Phi \in H$  and  $\perp \vdash \vartheta \in H$ . By induction hypothesis  $\Phi_A(\delta) \uparrow$  and  $\vartheta_A(\delta) \uparrow$  or  $\Phi_A(\delta) \uparrow$  and  $\vartheta_A(\delta) = F$  or  $\Phi_A(\delta) = F$  and  $\vartheta_A(\delta) \uparrow$ . Therefore  $(\Phi \vee \vartheta)_A(\delta) \uparrow$ .

Let  $\perp \Box \Phi \in H$ . By  $H \Box \cup$  we have  $\perp \Phi \in H$  or  $\neg \Phi \in H$ . By induction hypothesis  $\Phi_A(\delta) = T$  or  $\Phi_A(\delta) = F$ , this gives  $\Phi_A(\delta) \downarrow$ , therefore  $\Box \Phi_A(d) \uparrow$ .

Let  $\perp \Box \Phi \in H$ . By  $H \Box \perp$  we have  $\perp \Phi \in H$ . By induction hypothesis  $\Phi_A(\delta) \uparrow$ , therefore  $\Box \Phi_A(d) = T$ .

**Theorem 7.** Let  $\wp$  be unclosed path in a sequent tree for  $\perp \Gamma \perp U \neg \Delta$  and  $H$  be the set of all formulas in  $\wp$ . Then  $H$  is a model set.

*Proof.* We should check that  $H$  satisfies all requirements that specify a model set. Details can be found in [12] but additionally undefinedness conditions should be taken into account.

The completeness theorem follows from Theorems 6 and 7.

**Theorem 8 (completeness).** Let  $U/\Gamma \models_{IR} \Delta$  hold. Then sequent  $\perp \Gamma \perp U \neg \Delta$  is derivable in  $C^{QCR}$ .

*Proof.* Assume that  $U/\Gamma \models_{IR} \Delta$  and  $\perp \Gamma \perp U \neg \Delta$  is not derivable. In this case a sequent tree for  $\perp \Gamma \perp U \neg \Delta$  is not closed. Thus, an unclosed path  $\wp$  exists in this tree. Let  $H$  be the set of all formulas of this path. By Theorem 7,  $H$  is a model set. By theorem 6 this means that a counter-model for  $\perp \Gamma \perp U \neg \Delta$  was constructed. But this contradicts to  $U/\Gamma \models_{IR} \Delta$ .

## 5. Conclusion

The efficiency of program verification heavily depends on program logics supporting corresponding verification methods. Traditional Floyd-Hoare logic and its variants are oriented on total pre- and post-conditions (total predicates) and do not support partial predicates. In this paper we have studied a new method for constructing sound program logics. This method is based on extending program logics with the composition of predicate complement. The method permits to construct a sound calculus for program logic but it makes the calculus more complicated because undefinedness conditions should be taking into consideration.

Also, introduction of partial predicates required extension of a base predicate logic to a logic of partial quasiary predicate. For this logic we have defined and investigated a special consequence relation called irrefutability consequence relation with undefinedness conditions. For a case of quantifier-free predicate logic of partial quasiary predicates (renominative level) we have constructed a calculus of sequent type and proved its soundness and completeness.

In the future we plan to construct a sequent calculus for predicate logic over hierarchical nominative data and prove its soundness and completeness. Also, we plan to develop a prototype of theorem prover oriented on such logics. Initial steps were made in [15].

## References

- [1] Abramsky, S., Gabbay, D., Maibaum, T. (editors). Handbook of Logic in Computer Science, Oxford University Press, Vol. 1–5 (1993–2000)

- [2] Hoare, C.: An axiomatic basis for computer programming, *Commun. ACM* 12(10), 576–580 (1969)
- [3] Apt, K.: Ten years of Hoare’s logic: a survey - part I, *ACM Trans. Program. Lang. Syst.* 3(4), 431–483 (1981)
- [4] Kryvolap, A., Nikitchenko, M., Schreiner, W.: Extending Floyd-Hoare logic for partial pre- and postconditions. In: *Communications in Computer and Information Science*, vol. 412, pp. 355–378. Springer, Cham (2013)
- [5] Nikitchenko, M., Kryvolap, A.: Properties of inference systems for Floyd-Hoare logic with partial predicates, *Acta Electrotechnica et Informatica*, 13(4), 70–78 (2013)
- [6] Ivanov, I., Nikitchenko, M.: On the sequence rule for the Floyd-Hoare logic with partial pre- and post-conditions. In *Proceedings of the 14<sup>th</sup> International Conference on ICT*, vol. 2104 of *CEUR Workshop Proc.*, pp. 716–724 (2018)
- [7] Nikitchenko, M., Ivanov, I., Kornilowicz, A., Kryvolap, A.: Extended Floyd-Hoare logic over relational nominative data. In: Bassiliades, N., Ermolayev, V., Fill, H.G., Yakovyna, V., Mayr, H.C., Nikitchenko, M., Zholtkevych, G., Spivakovsky, A. (eds.) *Information and Communication Technologies in Education, Research, and Industrial Applications*. pp. 41–64. Springer International Publishing, Cham (2018)
- [8] Nikitchenko, N.S.: A composition-nominative approach to program semantics. Technical report, IT-TR 1998–020, Technical University of Denmark (1998)
- [9] Nikitchenko, M., Shkilniak, S.: *Mathematical logic and theory of algorithms*. Kyiv: VPC Kyivskiyi Universytet, in Ukrainian (2008)
- [10] Nikitchenko, M., Tymofieiev, V.: Satisfiability in Composition-Nominative Logics, *Open Computer Science (former Central European Journal of Computer Science)*, vol. 2, issue 3, pp. 194–213 (2012)
- [11] Nikitchenko, M., Ivanov, I., Skobelev, V.: Proving properties of programs on hierarchical nominative data, *Comput. Sci. J. Moldova*, 24(3(72)), 371–398 (2016)
- [12] Nikitchenko, M., Shkilniak, S.: Algebras and logics of partial quasiary predicates, *Algebra and Discrete Mathematics*, vol. 23. No 2, pp. 263–278 (2017)
- [13] Kornilowicz, A., Ivanov, I., Nikitchenko, M.: Kleene algebra of partial predicates. *Formalized Mathematics*, 26, 11–20 (2018)
- [14] Nikitchenko, M., Shkilniak, O. Shkilniak, S.: Pure first-order logics of quasiary predicates, *Problems in Programming*. No 2–3, pp. 73–86, in Ukrainian (2016)
- [15] Kornilowicz, A., Kryvolap, A., Nikitchenko, M., Ivanov, I.: Formalization of the nominative algorithmic algebra in Mizar. In: J. Świątek, L. Borzemski, Z. Wilimowska (eds.) *ISAT 2017, AISC*, vol. 656, pp. 176–186. Springer, Cham (2018)

# Agent-Oriented Information Technology for Assessing the Initial Stages of the Software Life Cycle

Tetiana Hovorushchenko<sup>1[0000-0002-7942-1857]</sup>, Artem Boyarchuk<sup>2[0000-0001-7349-1371]</sup>,  
Olga Pavlova<sup>3[0000-0003-2905-0215]</sup> and Kira Bobrovnikova<sup>4[0000-0002-1046-893X]</sup>

<sup>1, 3, 4</sup> Khmelnytskyi National University, Instytutska str., 11, Khmelnytskyi, Ukraine

<sup>2</sup> National Aerospace University "Kharkiv Aviation Institute"

<sup>1</sup> tat\_yana@ukr.net

<sup>2</sup> a.boyarchuk@csn.khai.edu

<sup>3</sup> olya1607pavlova@gmail.com

<sup>4</sup> bobrovnikova.kira@gmail.com

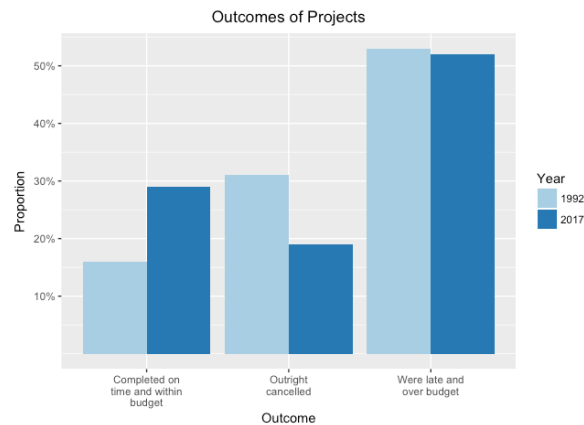
**Abstract.** The paper presents the development of agent-oriented information technology (AOIT) for assessing the sufficiency of information at the initial stages of the software life cycle. This AOIT performs automatic assessments and provides improving the level of sufficiency information of requirements for determination of each non-functional characteristic separately and all non-functional characteristics together, with the result that the gap in knowledge about non-functional characteristics for software is reduced. In addition, the developed AOIT minimizes the impact of the human factor and simplifies the performance of this assessment both by the developer and the customer. The developed agent-oriented information technology also provide: automation of the tedious, time-consuming, fatiguing and error-prone task of parsing the SRS; instantly show where re-work of requirements is needed; speed training for new systems engineers and project managers; the authoring of high-quality requirements; the correction and elimination of the requirements errors where they originate – during the early stages of the project; the tool for choosing the more qualitative software requirements specification; free online access, at any time, without any registration.

**Keywords:** Software Requirements, Software Requirements Specification (SRS), Sufficiency of Requirements Information, Non-Functional Software Characteristics, Ontology-Based Intelligent Agent (OBIA), Agent-Oriented Information Technology (AOIT).

## 1 Introduction

Humanity is now increasingly relying on software when it comes to solving complex problems and the number of software projects with a high cost is growing rapidly. Today in the world more than 250 billion USD is spent annually on the development of approximately 175 thousand software projects. The average cost of a software project for the large company is 2.322 million USD, for the average company – 1.313 million USD, and for the small company – 434 thousand USD [1, 2]. At the same

time, a significant number of software projects are unsuccessful (with overtime, over costs, lack of functional or canceled to completion and never used). On average, only 16-29% of software projects are executed within the scheduled time and budget (for large companies - 9-16% of projects); software projects of the largest US companies have only about 42% of the required capabilities and functions [1, 2] – Fig.1 [3].



**Fig. 1.** Comparative statistics on the success of software projects in 1992 and 2017, according to The Standish Group International [3].

A significant quantity of bugs is introduced into the software at the early stages of the life cycle due to information losses due to the incomplete and different understanding of the needs and information context (10-23% of all bugs) [4, 5]. The authors of [6] give an even bigger percentage – 56% of all defects of software projects are introduced during the requirements definition stage. About 50% of requirements defects are the result of poorly written, unclear, ambiguous or incorrect requirements; *the other 50% is due to the incompleteness of specification* (incomplete, insufficient and omitted requirements) [6]. So, deficient requirements are the single biggest cause of software project failure.

The study on the relative cost of fixing engineering errors during the various phases of a project development cycle provided one finding common conclusion to all the software studies they examined and all the systems development projects they studied: the cost to fix software defects rose exponentially with each successive stage of the project life cycle [6]. This is one more compelling argument in favor of finding and correcting requirements errors where they occur – at the very beginning of the software project.

Consequently, the issues of the analysis and evaluation of the initial stages of the life cycle have a critical impact on software projects and on the success of their implementation. Then today, when the number of high-budget software projects is rapidly growing, the analysis of the software requirements specifications (SRS) and the possibility of the automated evaluation of the level of elaboration of the initial stages of the software life cycle are *actual problems* – in particular, identifying and eliminating the disadvantages of the initial stages of the software life cycle and the facts of the insufficiency of information of requirements to software (moreover special attention needs information about the non-functional characteristics of software).

## 2 Related Works

Today the following approaches for assessing the sufficiency of information of requirements to the software are known – Table 1. The review of the known information technologies, tools and intelligent agents for analyzing the software requirements is given in Table 2.

**Table 1.** The review of approaches to assessing the sufficiency of information of requirements to software

<i>The approach</i>	<i>Limitations of the approach</i>
Model for validation of sufficiency of safety requirements, focusing on sufficiency of hazard identification, hazard analysis, and software safety requirements traceability [7, 8]: several different metrics have been introduced, in particular, Percent Software Safety Requirements – as the ratio of the number of software safety requirements to the total number of software requirements; the authors suggest comparing this metric with a similar metric for implemented software, on the basis of this comparing the conclusion about the sufficiency of software safety requirements is made	On the basis of the proposed metric, only the sufficiency of the number of safety requirements can be assessed, but not the sufficiency of their information; the impossibility of interpretation by comparing the proposed metric for fundamentally new software; there is no tool for automatically identifying and calculating the safety requirements in the SRS
Evaluation of testing sufficiency as the achievement of the test coverage levels recommended or mandated by safety standards and industry guidelines [9]	The approach is aimed only at verification of software and requirements, but not at the validation of the developed software and customer needs; the approach uses the SRS solely as an input for the developed tool, but doesn't check the requirements of the specification for their sufficiency
Theoretical and applied principles of evaluating the sufficiency of the information on quality in the SRS [10]	Automation of such evaluation is not realized. This approach will be evolved during further solving the task of automated analysis of SRS

**Table 2.** The review of information technologies, tools and intelligent agents for software requirements analysis

<i>Information technology (IT) or tool or intelligent agent (IA)</i>	<i>Limitations of the IT or tool or IA</i>
<i>1</i>	<i>2</i>
CORE: enables the user to extract the requirements from the source documentation and then analyzes them for completeness, consistency and testability [11]	Checks the completeness of the SRS with respect to business requirements, but doesn't provide to check business requirements for their completeness



1	2
Visure – checker of requirements quality using natural language processing and semantic analysis [12]	Doesn't provide validation of compliance with the requirements of the SRS to the needs of the customer
Accompa: provides automatic requirements gathering; automatically detects & track dependencies between requirements [12]	Commercial tool – costs at just \$199/month with no installation and maintenance [13]; doesn't check if all needs and requirements of the user have been reflected in the SRS
Innoslate: analyzes requirements using natural language processing technology [12]	Commercial tool – Innoslate Cloud is priced at \$49/user/month and Innoslate Enterprise – \$199/user/month [13]; doesn't provide quantitative assessments of the properties of SRS information
ReqView: organizes requirements into a tree hierarchy, uses rich text format for requirements description [12]	Doesn't verify and validate the requirements of the specifications for the needs of the customers
Modern Requirements4TFS: runs traceability analyses to ensure quality and find gaps or dependencies in requirements [12]	Doesn't identify the needs of the user that were not reflected in the requirements; doesn't provide visualization of the found gaps in the requirements
Natural language processing (NLP) Requirements Analysis Tools (for example, QVscribe): automate and significantly speed the searching the possible errors in natural language documents with requirements; provide visual scoring of each assessed requirement [6]	Doesn't reveal information losses in the formation of requirements
Requirements Analysis Tool: uses of user-defined glossaries to extract structured content; Semantic Web technologies are leveraged for deeper semantic analysis of the extracted structured content to find various kinds of problems in requirements documents [14]	Limitation of the glossary on which the tool is based
QARCC (Quality Attribute Risk and Conflict Consultant): is the tool for supporting conflict identification and requirements negotiation; it is a knowledge-based tool used to identify and analyze the conflicts in early development cycle [15]	Doesn't check the sufficiency of SRS requirements (in particular, non-functional requirements)
Requirements Assistant: identifies the missing requirements and inconsistency in requirements; detect the lack of some type of non-functional requirement such as reliability, security, safety [16]	Commercial tool; doesn't provide quantitative assessments (metrics) about missing non-functional requirements

<i>1</i>	<i>2</i>
QuARS Requirements Analysis Tool: provides screening of the requirements on consistency, completeness; identifies 37% of requirements defects [15, 17]	Commercial tool
DESIRE: ensures that the rules of completeness, non-ambiguity and comprehensibility are respected [18]	Commercial tool
RQV Tool (Requirement Quality Verification Tool) [18]: a semi-automatic verification tool for SRS based on a comprehensive quality model; can help in the verification of the quality of the SRS on the basis of ISO 29148:2011	Provides assessments of the quality of SRS information, but not its completeness or sufficiency
The ontology-based intelligent agent (OBIA) for eliminating the ambiguity in gathered software requirements and for facilitating the communication with the stakeholders [19]	Doesn't check whether all user needs have been reflected in such requirements, whether the requirements of the SRS are sufficient
The OBIA-based tool that uses instantiated ontological designs to generate programming code on the basis of the SRS [20]	Doesn't verify and validate the STS requirements for the needs of the customers, doesn't assess the sufficiency of the available information in the SRS requirements, doesn't identify the needs that were not reflected in the requirements (in particular, non-functional)
Information technology for assurance of veracity of quality information in the SRS: evaluation of the sufficiency of the volume of the quality information in the SRS [21]	The required SRS, which is structured according to ISO 29148:2011 [22]. This IT will be evolved during the further automated analysis of the SRS

The review of known information technologies, tools and intelligent agents for the SRS analysis has shown, that there are a number of effective solutions, but they all belong to different methodological approaches and are designed to different tasks. But, there is currently no information technology for assessing the sufficiency of information at the initial stages of the software life cycle. The actuality of the task of automated evaluation of the level of elaboration of the initial stages of the software life cycle on the basis of the analysis of specifications (in particular, the automated assessment of the sufficiency of information in the SRS), and the lack of information technology for assessing the sufficiency of information at the initial stages of the software life cycle causes *the need of development of agent-oriented information technology for assessing the sufficiency of information at the initial stages of the software life cycle*. This IT will be based on natural language processing (NLP) and will significantly reduce the cost of fixing requirements errors by finding them earlier and faster, and to free experts of the concrete subject domain from tedious, time-consuming tasks that waste their expertise.

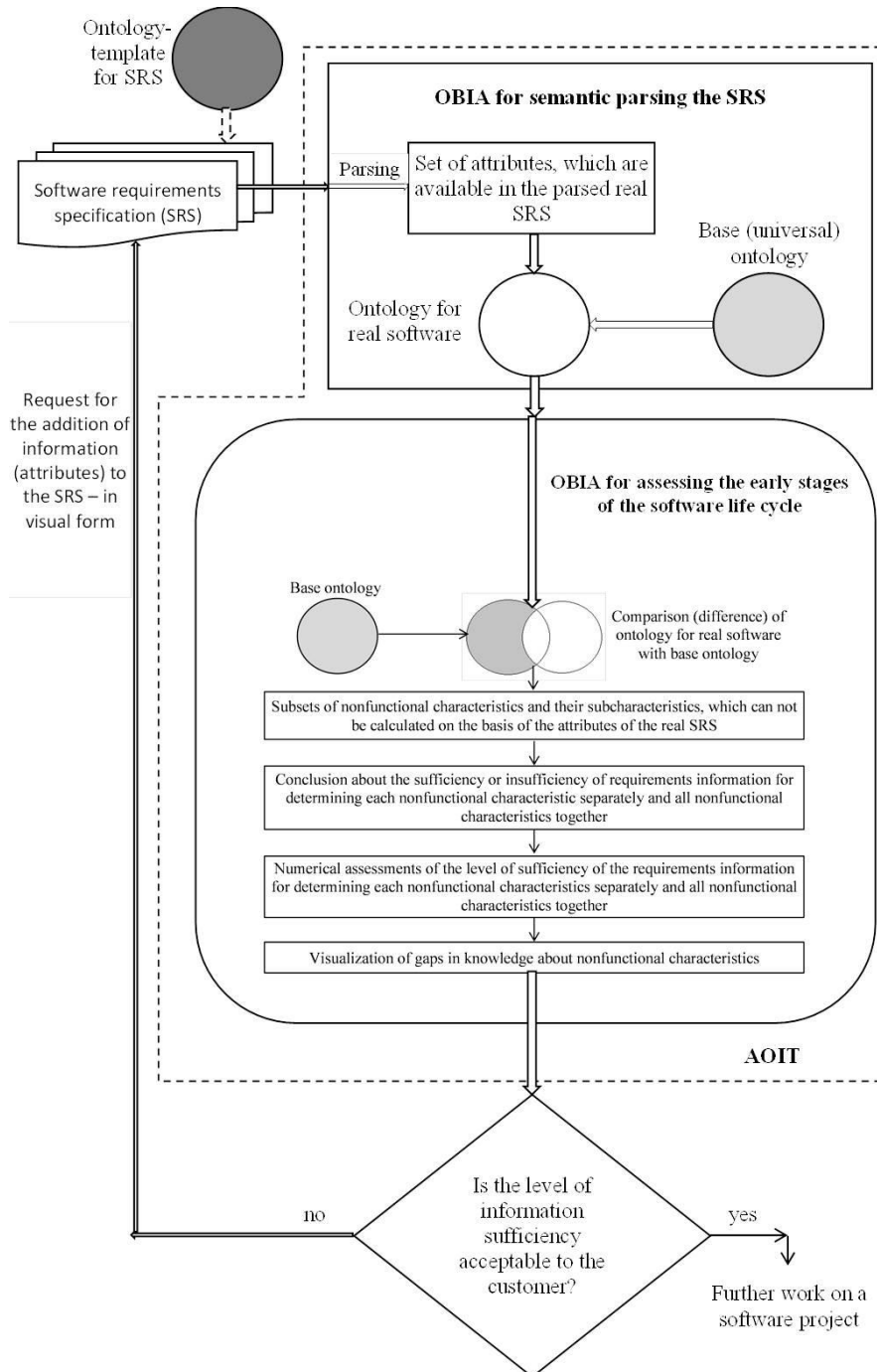
### **3 Agent-Oriented Information Technology (AOIT) for Assessing the Sufficiency of Information at the Initial Stages of the Software Life Cycle**

Agent-oriented information technology (AOIT) for assessing the sufficiency of information at the initial stages of the software life cycle solves the task of assessing the sufficiency of requirements information for determining only non-functional characteristics of software, which are software quality characteristics. According to ISO 25010 [23], such non-functional characteristics are reliability, functional suitability, performance efficiency, compatibility, maintainability, portability, security, usability. Subcharacteristics of such non-functional characteristics are also determined by ISO 25010 [23]. Attributes, on the basis of which such non-functional characteristics and their subcharacteristics are calculated, are determined by ISO 25023 [24]. Then, the sufficiency of requirements information for determining above non-functional characteristics is determined by the presence in the SRS all the attributes, which are necessary for determining the non-functional characteristics (203 attributes, including 138 different attributes).

Taking into account the theoretical principles of the information technology for evaluating the sufficiency of information on quality in the SRS [10] and the movement of information flows in the process of assessing the sufficiency of requirements information for determining the non-functional characteristics, the AOIT for assessing the sufficiency of information at the initial stages of the software life cycle is developed (as a set of processes using tools and methods of accumulation, processing and transmission of primary information for obtaining information of new quality on the status of the object, subject or phenomena) – Fig. 2.

The purpose of the developed AOIT is the automation of a quantitative assessment of the level of sufficiency of requirements information for determining the non-functional characteristics, minimization of the impact of the human factor, facilitation of the implementation of this assessment both by the developer and the customer. AOIT provides the identification of the need for forming the query to add attributes, which are necessary for determining the non-functional characteristics, and, if necessary, forms and visualizes its contents. The developed AOIT automatically processes available knowledge (non-functional requirements of the SRS) and generates new knowledge (conclusions about the sufficiency of requirements information, about the level of information sufficiency, recommendations for improving the level of information sufficiency in the SRS). As can be seen from Fig. 2, the developed AOIT is based on the ontology-based intelligent agent (OBIA) for semantic parsing of the SRS [25] and OBIA for assessing the early stages of the software life cycle [26].

The OBIA for semantic parsing the SRS accepts the SRS as the input data and automatically parsing the SRS on the subject of finding the attributes, which are necessary for determining the non-functional characteristics of the software. The SRS template, which demonstrates all the necessary attributes for determining the non-functional characteristics, and their location in the SRS, is proposed to the user in the form of the base ontology of domain "Software Engineering" (part "Software Requirements Specification (attributes)"), developed in [21] on the basis of ISO 29148 [22].



**Fig. 2.** AOIT for assessing the sufficiency of information at the initial stages of the software life cycle.

After the parsing of the SRS, this OBIA forms the set of attributes, which are available in the parsed real SRS. Using the developed in [21] base ontology for the non-functional characteristics (as the known fact) and the obtained set of the available attributes, this OBIA generates the ontology for real software, which transmits as input data to other OBIA (to OBIA for assessing the early stages of the software life cycle).

OBIA for assessing the early stages of the software life cycle carries the comparison of the base ontology for non-functional characteristics (known fact) with the obtained ontology for real software. As a result of this comparison, this OBIA, according to the developed in [26] method, forms the subsets of non-functional characteristics and their subcharacteristics, which can not be calculated on the basis of the attributes of the real SRS; concludes about the sufficiency or insufficiency of requirements information for determining non-functional characteristics; calculates numerical assessments of the level of sufficiency of the requirements information for determining each non-functional characteristics and all non-functional characteristics together; provides visualization of gaps in knowledge about non-functional characteristics.

If the level of information sufficiency is 100% (for example, for critical software) or is acceptable for the customer (but we recommend the level of sufficiency no less 85% with the purpose of minimization of information losses during the initial stages of the software life cycle), then the further work on the software project is performed; otherwise, the SRS developers are requested to add the required attributes to the SRS (with visualized hints, which attributes should be added), after which the SRS may be re-analyzed by the developed AOIT.

The developed AOIT makes it possible to compare different SRS for software projects with the same cost and duration; to guarantee the inclusion in the requirements of the information, which are necessary for the further determination of non-functional characteristics, thereby reducing the gap in knowledge about non-functional characteristics for software projects. The main advantage of the developed AOIT is the automation of the processes of parsing the SRS and of assessing the sufficiency of the requirements information for determining the non-functional characteristics, due to this eliminating the subjective influence of the person, and saving the information in the software company in the event of dismissal of a specialist.

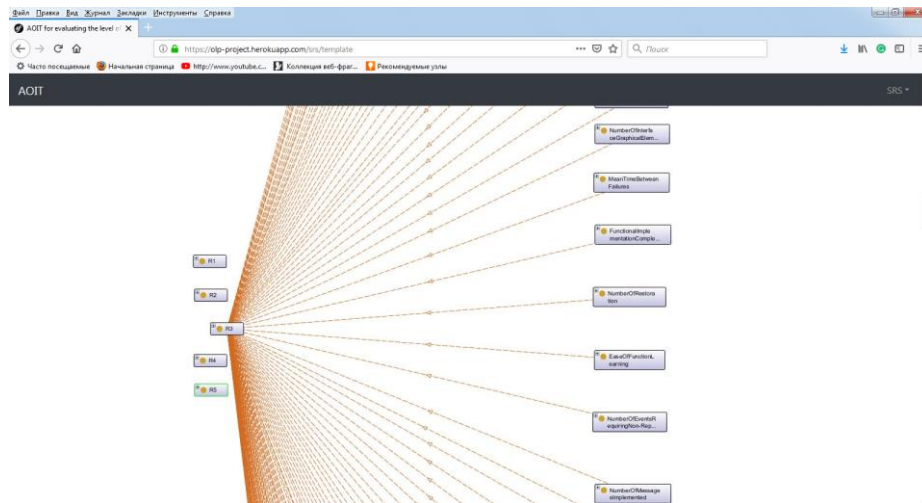
Another important advantage of the developed AOIT is low cost of parsing (translating) the human-spoken (natural language) requirements, because it provides the analysis of the requirements on the subject of identification of the availability or absence (miss) of attributes, which are necessary for determining the non-functional characteristics. Since for determining the sufficiency, it is only necessary to know whether there is the attribute in the requirements or it is missing in the requirements, so the rules for parsing the SRS, on the basis of which the developed agent works, are so simple (if <attribute> is found in the SRS, then <attribute> is the element of the set of available attributes, else <attribute> is the element of the set of missing attributes). The simplicity of these rules provides a high speed and low cost of parsing the natural language requirements.

## 4 The Results of Functioning the AOIT for Assessing the Sufficiency of Information at the Initial Stages of the Software Life Cycle

AOIT for assessing the sufficiency of information at the initial stages of the software life cycle is implemented in the PHP language in the form of free software and is available by the link – <https://olp-project.herokuapp.com>.

Before uploading the SRS for its processing, the user of AOIT can acquaint with the template of the SRS, which demonstrates all the necessary attributes for determining the non-functional characteristics, and their location in the specification. This template of SRS is presented in the form of ontology. The SRS can have any structure, any form, but for further evaluating the non-functional characteristics it should have the values of the attributes from ISO 25023:2016. Exactly these attributes are in the visual ontology-template as the hints to the user. The fragment of such ontology-template for SRS is represented on Fig. 3.

For analysis, the user of developed AOIT must upload the SRS in pdf-format. After this, the AOIT parses the uploaded specification and on the basis of it generates the ontology for real software in owl-format, which the user can download for further work.



**Fig. 3.** Fragment of ontology-template for SRS of AOIT for assessing the sufficiency of information at the initial stages of the software life cycle.

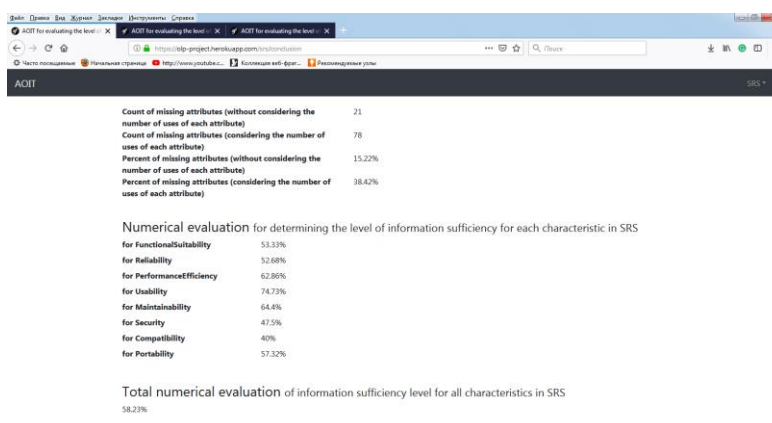
After comparing the ontology for real software with base ontology for non-functional characteristics, the developed AOIT gives the conclusion on the sufficiency of requirements information, which consists of: the number and percentage of missing attributes (during this counting, AOIT gives two these numbers – without and with taking into account how many times the missing attribute is used when the determination of subcharacteristics of non-functional characteristics (without and with repetitions)); quantitative assessments of the sufficiency of requirements information for

determining each non-functional characteristic and all non-functional characteristics together. In addition, the developed AOIT proposes the list of missing attributes in the form of a list, which is divided by subcharacteristics of non-functional characteristics, which provides visualization of missing attributes for determining one or another subcharacteristics of non-functional characteristic.

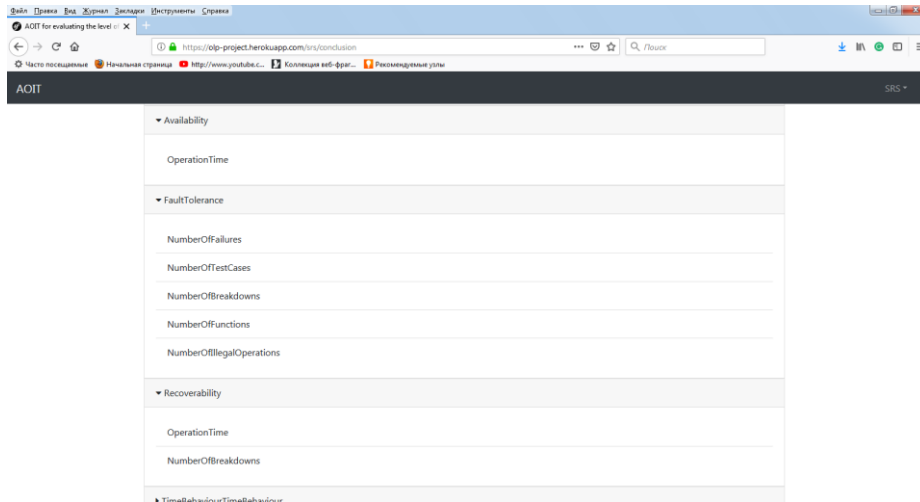
For the experiment, three requirements specifications to software for accounting for the provision of Internet access services, which are developed for ITT Ltd (Khmelnitsky, Ukraine) by various software companies of Khmelnitsky. These SRS have approximately the same cost and duration, so the choice of the SRS according to these criteria is difficult.

As a result of the analysis of SRS No. 1, the developed AOIT has provided the following conclusions – Fig. 4, Fig. 5. As a result of the analysis of SRS No. 2, the developed AOIT has provided the conclusions, which are presented in Fig. 6. After analysis of the SRS No. 3, the developed AOIT has provided the following conclusions – Fig. 7.

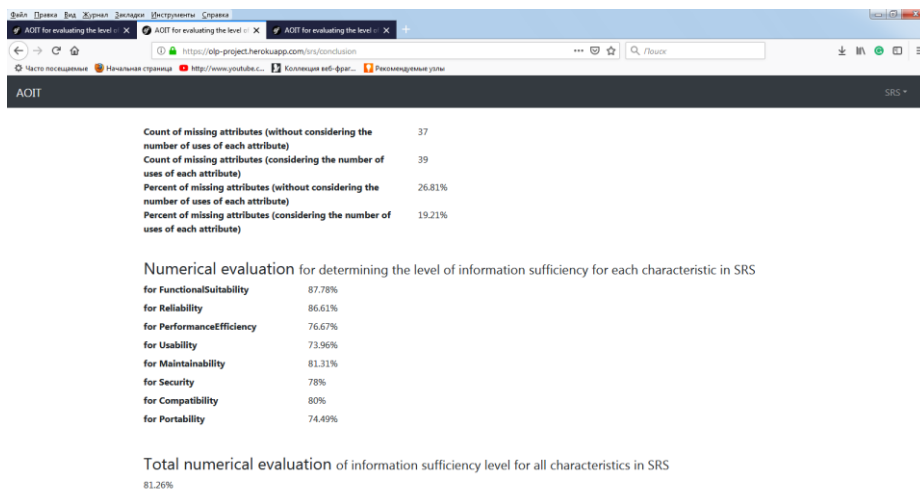
The analysis of the results of the developed AOIT confirmed the regularity, which is identified in [21], that more important and priority are attributes, which impact on more than one subcharacteristic of non-functional characteristics. So, in SRS No. 1 there are no 21 attributes without considering the number of uses of each attribute when determining the subcharacteristics of non-functional characteristics (but there are no 78 attributes, considering the number of uses of each attribute). In SRS No. 2 there are no 37 attributes without considering the number of uses of each attribute (but there are no 39 attributes, considering the number of uses of each attribute). In SRS No. 3, there are no 37 attributes without considering the number of uses of each attribute (but there are no 74 attributes, considering the number of uses of each attribute). At the same time, the level of sufficiency of requirements information of SRS No. 1 for determining all non-functional characteristics is 58,23%, the level of sufficiency of requirements information of SRS No. 2 – 81,26%, the level of sufficiency of requirements information of SRS No. 3 – 60,85%.



**Fig. 4.** Quantitative assessments of the sufficiency of requirements information (SRS No. 1) for determining the non-functional characteristics (which are provided by the developed AOIT).

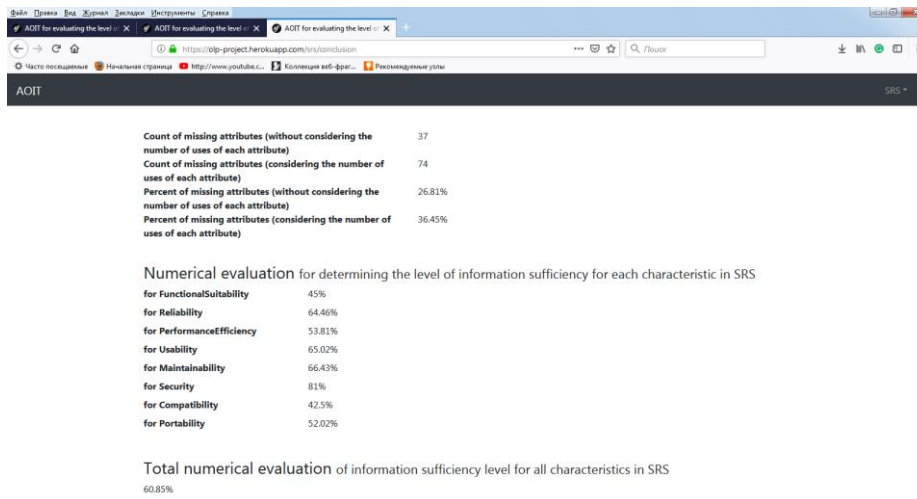


**Fig. 5.** Visualization of missing attributes (in SRS No. 1) for determining the three subcharacteristics of the non-functional characteristic "Reliability" (which is provided by the developed AOIT).



**Fig. 6.** Quantitative assessments of the sufficiency of requirements information (SRS No. 2) for determining the non-functional characteristics (which are provided by the developed AOIT).





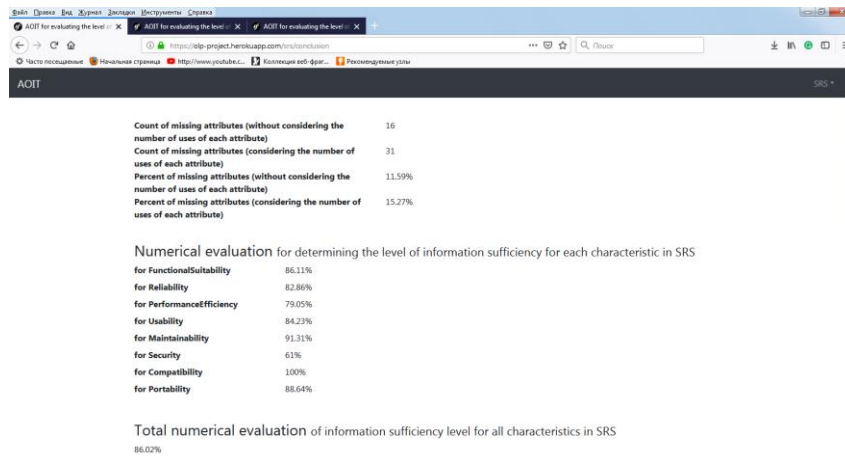
**Fig. 7.** Quantitative assessments of the sufficiency of requirements information (SRS No. 3) for determining the non-functional characteristics (which are provided by the developed AOIT).

Thus, with less number of missing attributes (without considering the number of uses of each attribute), SRS No. 1 has a lower level of information sufficiency than SRS No. 2, in which more attributes are absent (without considering the number of uses of each attribute). This situation is explained by the fact that in SRS No. 1 there is no greater number of attributes (in comparison with the SRS No. 2), which impact on more than one subcharacteristic of non-functional characteristics. This fact is proved by the number of missing attributes, which are provided by the AOIT (considering the number of uses of each attribute).

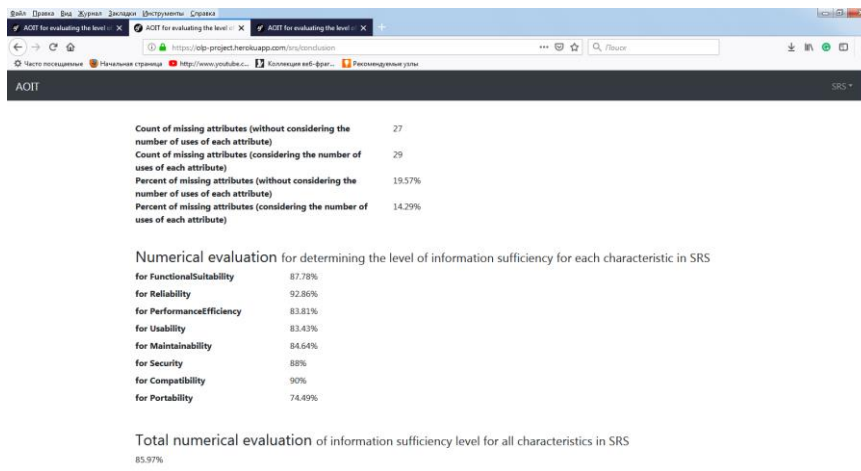
In the result of the analysis of the conclusions of the developed AOIT, the customer of the software for accounting for the provision of Internet access services (ITT Ltd) decided that the level of sufficiency of the requirements information in all three SRS isn't acceptable for the transition to further work on the software project. Therefore, all three SRS were sent back to developers for revision (in part of supplementing the attributes for determining the non-functional characteristics). The revised SRS were also analyzed by the developed AOIT. The conclusions of the AOIT after the analysis of the revised SRS are presented in Fig. 8-10.

In the SRS No. 1, 5 attributes were added without considering the number of uses of each attribute in determining the subcharacteristics of non-functional characteristics (47 attributes, considering the number of uses of each attribute). In SRS No. 2, 10 attributes were added without considering the number of uses of each attribute (and 10 attributes, considering the number of uses of each attribute). In SRS No. 3, 10 attributes were also added without considering the number of uses of each attribute (25 attributes, considering the number of uses of each attribute). At the same time, the level of sufficiency of requirements information of the SRS No. 1 for determining all non-functional characteristics is already 86,02%, the level of sufficiency of requirements information of the SRS No. 2 – 85,97%, the level of

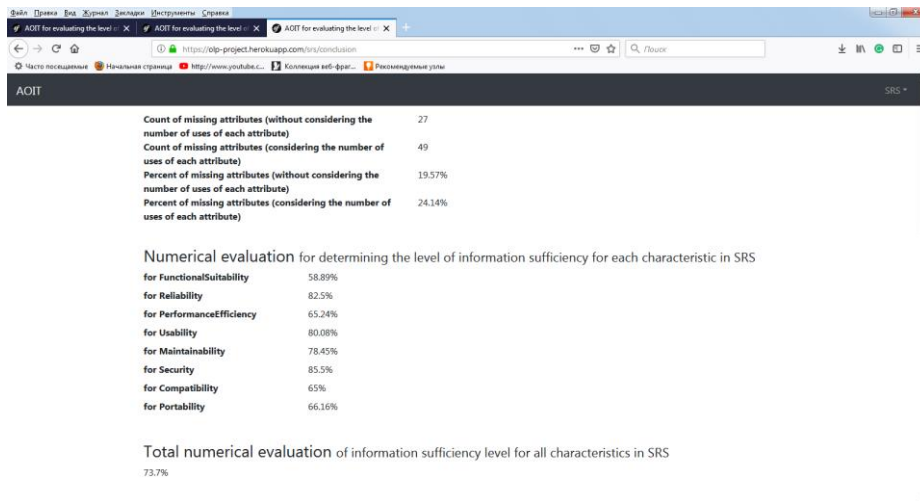
sufficiency of requirements information of the SRS No. 3 – 73,7%. Consequently, the conclusions of the developed AOIT for assessing the sufficiency of information at the initial stages of the software life cycle provide increasing the level of sufficiency of requirements information for determining the non-functional characteristics, respectively, by 27,79%, 4,71% and 12,85% for SRS No. 1-3.



**Fig. 8.** Quantitative assessments of the sufficiency of requirements information (SRS No. 1, after revision), which are provided by the developed AOIT.



**Fig. 9.** Quantitative assessments of the sufficiency of requirements information (SRS No. 2, after revision), which are provided by the developed AOIT.



**Fig. 10.** Quantitative assessments of the sufficiency of requirements information (SRS No. 3, after revision), which are provided by the developed AOIT.

We (the developers of AOIT) recommend the level of sufficiency equal 85% is acceptable, but the final decision regarding the required level of sufficiency is taken by the customer of the software. The customer can set a lower threshold of this level, for example, 90%, 95% or 100% (even for non-critical software). So, in the result of the analysis of the conclusions of the developed AOIT, ITT Ltd decided that the level of sufficiency of the requirements information of SRS No.1 and SRS No. 2 is already accepted for the further work on the software project. ITT Ltd selected SRS No. 1 for further work. So, the customer was able to make a choice the SRS from the view of its information's sufficiency, but not only from the view of its cost and duration.

## 5 Conclusions

At present, the task of automated assessment of the level of elaboration of the initial stages of the software life cycle based on the analysis of specifications is actual (in particular, the automated assessment of the sufficiency of requirements information).

In this paper, the agent-oriented information technology for assessing the sufficiency of information at the initial stages of the software life cycle was developed. This AOIT assesses and provides the increase (for example, from 58,23% till 86,02% for SRS No. 1, from 81,26% till 85,97% for SRS No. 1, from 60,85% till 73,7% for SRS No. 3) of the level of sufficiency of requirements information for determining software non-functional characteristics – the gain of the level of sufficiency is from 4,71% to 27,79%.

In addition to the above, *the advantages of the developed AOIT* also are: 1) automation of the time-consuming, routine and error-prone task of parsing the SRS, and almost instantly accomplishment of it; 2) indication where re-work on SRS is needed (the user can browse missing attributes and see SRS areas which the extra attention is needed, and which requirements need re-work); 3) provision of training for new SRS developers,

systems engineers and project managers (using this AOIT helps them see mistakes they might be making, and helps them recognize those mistakes in others' work); 4) help of developing the high-quality requirements; 5) help of correct and eliminate of requirements errors where they originate – during the early stages of the software project life cycle – before they become more expensive to correct; 6) provision of the tool for choosing the more qualitative software requirements specification; 7) free online access, at any time, without any registration.

The *economic effect* of the use of the developed AOIT is the ability to save software projects' budget for processing and correcting (during the life cycle) defects and bugs, which are made at the early stages of the life cycle - due to the demonstration of weaknesses in the SRS, that need to be finalized or re-worked, at a time when they arise.

*The limitations of the developed AOIT* are: 1) the assessment of the only sufficiency of requirements information for determining the non-functional characteristics as the sufficiency of the attributes in the SRS; 2) consideration of only non-functional characteristics, which are regimented by ISO 25010 standard as the software quality characteristics; 3) non-consideration the other SQUARE standards of 25000-series (ISO 25011, ISO 25012); 4) during parsing the SRS the search of only attributes, which are defined by ISO 25023as necessary for the non-functional characteristics-components of software quality. For elimination of these limitations, further efforts of the authors will be directed.

## References

1. Hastie, S., Wojewoda, S.: Standish Group 2015 Chaos Report – Q&A with Jennifer Lynch, <http://www.infoq.com/articles/standish-chaos-2015>, last accessed 2019/02/12.
2. The Standish Group Report CHAOS, <https://www.projectsart.co.uk/white-papers/chaos-report.pdf>, last accessed 2019/02/12.
3. A Look at 25 Years of Software Projects. What Can We Learn?, <https://speedandfunction.com/look-25-years-software-projects-can-learn/>, last accessed 2019/02/12.
4. McConnell, S.: Code complete. Microsoft Press, Redmond (2013).
5. Levenson, N. G.: Engineering a safer world: systems thinking applied to safety. MIT Press, Massachusetts (2012).
6. Leveraging Natural Language Processing in Requirements Analysis: How to eliminate over half of all design errors before they occur, <http://qracorp.com/wp-content/uploads/2017/03/Leveraging-NLP-in-Requirements-Analysis.pdf>, last accessed 2019/02/12.
7. Cruickshank, K. J.: A validation metrics framework for safety-critical software-intensive systems. Naval Postgraduate School, Monterey (2009).
8. Michael, J. B., Shing, M. T., Cruickshank, K. J., Redmond, P. J.: Hazard analysis and validation metrics framework for system of systems software safety. IEEE Systems Journal. 4 (2), 186-197 (2010).
9. Baker, R., Habli, I.: An empirical evaluation of mutation testing for improving the test quality of safety-critical software. IEEE Transactions on Software Engineering. 39 (6), 787-805 (2013).
10. Hovorushchenko, T., Pomorova, O.: Information technology of evaluating the sufficiency of information on quality in the software requirements specifications. CEUR-WS. 2104, 555-570 (2018).

11. Software Requirements Engineering Tools, <http://ecomputernotes.com/software-engineering/software-requirements-engineering-tools>, last accessed 2019/02/12.
12. 30 Best Requirements Management Tools in 2019, <https://www.guru99.com/requirement-management-tools.html>, last accessed 2019/02/12.
13. Top 20+ Best Requirements Management Tools (The Complete List), <https://www.softwaretestinghelp.com/requirements-management-tools/>, last accessed 2019/02/12.
14. Verma, K., Kass, A.: Requirements Analysis Tool: A Tool for Automatically Analyzing Software Requirements Documents. *Lecture Notes in Computer Science*. 5318, 751-763 (2008).
15. Mahmood, H., Rehman, M. S.: Tools for software engineers. *International Journal of Research in Engineering & Technology*. 3 (10), 75-86 (2015).
16. Jones., V., Murray, J.: Evaluation of current requirements analysis tools capabilities for IV&V in the requirements analysis phase, <https://www.slideserve.com/shlomo/evaluation-of-current-requirements-analysis-tools-capabilities-for-ivv-in-the-requirements-analysis-phase>, last accessed 2019/02/12.
17. Raffo, D. M., Ferguson, R.: Evaluating the Impact of The QuARS Requirements Analysis Tool Using Simulation, <https://pdfs.semanticscholar.org/7e7d/4e6f5ab13d00ca57c87711e30cd080730f34.pdf>, last accessed 2019/02/12.
18. Konig, F., Ballejos, L., Ale, M.: A semi-automatic verification tool for software requirements specification documents. In: *Simposio Argentino de Ingeniería de Software Proceedings*. Sociedad Argentina de Informática e Investigación Operativa (2017).
19. Ossowska, K., Szewc, L., Weichbroth, P., Garnik, I., Sikorski, M.: Exploring an ontological approach for user requirements elicitation in the design of online virtual agents. *Information Systems: Development, Research, Applications, Education*. 264, 40-55 (2017).
20. Freitas, A., Bordini, R. H., Vieira, R.: Model-driven engineering of multi-agent systems based on ontologies. *Applied Ontology*. 12 (2), 157-188 (2017).
21. Hovorushchenko, T.: Information Technology for Assurance of Veracity of Quality Information in the Software Requirements Specification. *Advances in Intelligent Systems and Computing*. 689, 166–185 (2018).
22. ISO/IEC/IEEE 29148:2011. *Systems and software engineering. Life cycle processes. Requirements engineering* (2011).
23. ISO/IEC 25010:2011. *Systems and software engineering. Systems and software Quality Requirements and Evaluation (SQuaRE). System and software quality models* (2011).
24. ISO 25023:2016. *Systems and software engineering. Systems and software Quality Requirements and Evaluation (SQuaRE). Measurement of system and software product quality* (2016).
25. Hovorushchenko, T., Pavlova, O., Bodnar, M.: Modern Problems of Semantic Analysis of Software Requirements Specifications. *Scientific notes of Taurida National University after named V. I. Vernadsky: series "Technical Sciences"*. 30 (269) (2019). [in Ukrainian]
26. Hovorushchenko, T., Pavlova, O.: Method of Activity of Ontology-Based Intelligent Agent for Evaluating the Initial Stages of the Software Lifecycle. *Advances in Intelligent Systems and Computing*. 836, 169-178 (2019).

# Dynamic Signature-based Malware Detection Technique Based on API Call Tracing

Oleg Savenko<sup>[0000-0002-4104-745X]</sup>, Andrii Nicheporuk<sup>[0000-0002-7230-9475]</sup>, Ivan Hurman and  
Sergii Lysenko<sup>[0000-0001-7243-8747]</sup>

Khmelnitsky National University, Khmelnytsky, Ukraine  
{savenko\_oleg\_st@ukr.net, andrey.nicheporuk@gmail.com,  
devastator192@gmail.com, sirogyk@ukr.net}

**Abstract.** The paper presents a method for a malware's signature generation based on API call tracing. Technique allows malware detection using a proposed form of signature. The main idea of proposed signature generation is a difference between frequency and interaction of a critical API calls performed by malicious program and benign applications in the process of their own execution. Accordingly the program's behavior signature based on API call tracing consists of two components: the call frequency and the nature of the interaction of critical API calls. An analysis of the first component allows determining the distribution of the critical API calls by groups concerning their malicious activity and displays the quantitative component of the signature. An analysis of the second component of the signature provides an opportunity to distinguish malware from benign applications not only in the presence of critical API calls, but also in their interaction with each other. The experimental results showed that the effectiveness of the malware detection using proposed signatures is up to 96.56%.

**Keywords:** Malware, Cybersecurity, Signature, Behavior, API, API Call Tracing, Chi-Squared Test

## 1 Introduction

Today, the importance of the problem of cybersecurity is beyond doubt. Since new instance of malware are created and spread faster than the tools are able to identify them, there is always a gap in detection, which leads to computer systems' infection.

According to the McAfee threat report, the number of new samples of malicious software at the end of 2018 has exceeded 60 million [1]. Moreover, the total amount of malware continues to grow in exponentially. This is due to the creation of new technologies and tools for the malware development and improvement of the antivirus evasion techniques [2-4]. Therefore, the development of new methods for malicious software detecting remains an important task.

In this work we propose dynamic signature-based malware detection technique which involves executing a possibly malicious piece of code or executable and detecting its effect upon execution by using specialized monitoring mechanisms. As a feature of detection the API calls that made by executable was chosen. Application Programming Interface or API is a medium communicating layer between Windows

environment and executable. Experimental studies show that malicious and benign programs can be distinguished by API calls frequency performed by them [5].

So our goal is to develop a signature of executable that based on API calls, the analysis of which would allow to separate malware and benign applications.

## 2 Related works

Today, a number of methods and techniques are used to detect the malware by antivirus tools. The most important is signature analysis. A classic signature-based analysis is based on comparison of a byte patterns or a checksum demonstrates its inefficiency for malicious software that modifies its own code. Therefore, the attention of researchers is focused on the development of new approaches for the signatures generation on the basis of other features that would be able to describe the malware's behavior fully.

In [6] authors are focused on the problem of attack for sensible data with the aid of the virus scanner itself with the use of extracted signatures. The method for automatically deriving signatures from anti-virus software was proposed. Method involves steps: the determination of relevant bytes in each malware sample by utilizing feedback from the virus scanner over multiple runs; aligning the relevant bytes from samples with the same signature and merge them into a single sequence by employing the Needleman-Wunsch algorithm; the transformation the merged sequences into a valid signature format. However, in case then several signatures present in single malware binary, proposed method is not able to recognize any of them.

Authors of DeepSign [7] apply deep belief network (DBN) to solving the problem of malware signature generation and classification. It uses the Cuckoo sandbox to record the execution behavior of each malware. Then, it treats the behavior report as a raw text file and uses uni-grams to convert each report into a 20,000 bit vector. The bit vectors are then fed into deep belief network to generate signatures. Finally, the signatures are fed into a support vector machine for classification. Experiments on 1800 malware samples without benign applications show that DeepSign is able to reach 96.4% accuracy. However, in order to obtain the high reliability of the experiment, the test sets should contain, in addition to the malware, also benign applications, since the rate of false positives is no less important than the accuracy.

In work [8] authors have proposed a method which combines use signature-based and anomaly-based detections. The proposed framework mainly consists of three modules: a database of malware and the PE file, modules of static and dynamic analysis, and a module of classification by similarity analysis. The static analysis consists of the de-obfuscation of packed malware in order to know the packers names and the contribution level of each of them. A dynamic analysis module consists of a virtual environment set up by Cuckoo Sand-Box to run the executable files of malware without infecting the rest of the system. As a result a list of API call sequences that reflect the malware behavior of its code have been used to detect behavior such as network traffic, modifying a file, writing to stderr or stdout, modifying a registry value, creating a process. For classify malware behaviors similarity analysis and various machine learning algorithms were used.

Another API call signature-based approach to malware detection is presented in [9]. To have a higher level of abstraction, related Win-APIs have been mapped to 26

categories, which differ in the nature of the actions performed (files, system registry, etc.), so the behavior of each malware is captured through sequence of these 26 categories of APIs. In order to generate signature Context Triggered Piecewise Hash (CTPH) was computed. The concept of fuzzy hashing has been used as it has the capability to compare two different samples and determine the level of similarity between them. Instead of generating a single hash for a file, piecewise hashing generates many hashes for a file based on different sections of the file.

In [10] a new information technology for botnets detection based on the analysis of the botnets' behaviour in the corporate area network is proposed. Botnets detection is performing combining two ways: using network-level and host-level analysis. One approach makes it possible to analyze the behavior of the software in the host, which may indicate the possible presence of bot directly in the host and identify malicious software, and another one involves monitoring and analyzing the DNS-traffic, which allows making conclusion about network hosts' infections with bot of the botnet. Based on this information technology an effective botnets detection tool BotGRABBER was constructed. It is able to detect bots, that use such evasion techniques as cycling of IP mapping, "domain flux", "fast flux", DNS-tunneling.

The mentioned above methods of detecting viruses have shown a high level of effectiveness, but inserting and executing dummy and redundant API calls can lead to an increase the false positives rate.

Therefore, this study is focused on a problem of creation malware detection method, the basis of signature generation, which is invariant to small scale changes.

### **3 Dynamic signature-based malware detection technique based on API call tracing**

The usage the obfuscation and anti-evasion techniques in malware disables the possibility to isolate a constant part of program code, the analysis of which would make it possible to detect a possible infection. However, it becomes possible using the API calls as the basis for signature, that is, the set of classes, procedures, functions, structures and constants provided by the application or the operating system for use by the external software products.

In order to implement a malware detection process, a new technique has been developed. It involves the following steps:

1. Data preprocessing:
  - 1.1 Signature generation for malware class based on API call tracing of each malware instance;
  - 1.2 Determination of the membership degree of each sample to malware class.
  - 1.3 Construction of a database for malware's behaviors classes and its membership degrees to each classes.
2. Detection of a malicious program represented by signature of program behavior based on API call tracing:
  - 2.1 Monitoring of the executables and their API call tracing;
  - 2.2 Signature construction of the suspicious program;
  - 2.3 The search of the virus signature within the class and the determination whether the suspicious program belongs to one of the malware's class;



## 2.4 Assignment the malware families (variant).

Let us take a closer look at each step of the method.

### 3.1 Data preprocessing.

The programs' executing process uses the API calls. For example, in order to perform the searching of the executable files to be infected, a virus program as a rule uses the following sequence of API calls: FindFirstFileA, FindNextFileA and FindClose, which are located in the KERNEL32.DLL library. Thus, the specified sequence of API calls can be used to build the signature of the malicious program. In general, it can be noted that the usage of API calls as a signature allows isolating a constant semantic (behavioral) component, while the syntactic component will be different.

In order to trace API call, the software that monitors and displays API calls made by observed applications and services was used. A result of the data preprocessing stage is a file with a list of API calls. The next stage of the method involves the signature generation based on API call tracing.

### 3.2 Signature generation based on API call tracing

Signature generation of the a malware instead of using all the API calls the malware performs, involves only critical API call [9, 10]. Critical API calls contain all API calls that can lead to security infraction, changes to the operating system's behavior or API calls used for communication (modification of the system registry value, Input/Output, API functions for network resources access, etc.). It should be noted that in the process of the malware's signature generation doesn't take into account the API calls which can be added or removed from the virus program without modifying its malicious behavior (for example, MessageBox, printf, etc.).

The signature of program behavior based on API call tracing can be presented as a set of two components (fig. 1): the call frequency and the interaction of the critical API calls. An analysis of the first component allows determining the distribution of the critical API calls by groups concerning their malicious activity and displays the quantitative component of the signature. The second component of the signature implies the mapping the nature of the interaction of malware's critical API calls into the vector space, and have describes their interactions.

In order to describe the nature of the critical API calls interaction, let us present the malware as a directed graph:

$$G_V = \langle V, E \rangle, \quad (1)$$

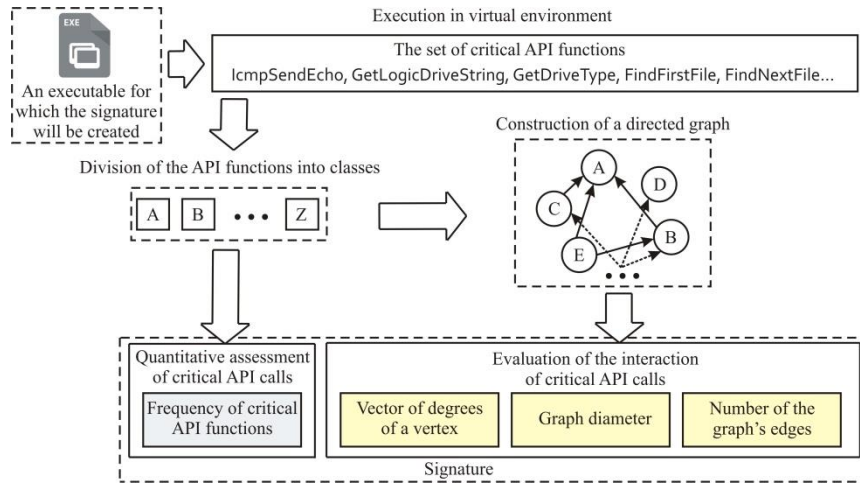
where  $V$  is a set of vertexes of a graph, which presents a group of critical API functions, and  $E$  is the set of transitions between groups of the critical API functions, which describe the malwares behavior.

For a formal definition of the malware's signature, let us present it as a tuple:

$$S = \langle A, F, \langle D, d_G, n_E \rangle \rangle, \quad (2)$$

where  $A$  is the set of API calls, performed by malware of the class  $C_i$ ;  $F$  is a set of frequencies of the critical API calls;  $D$  is vector of the graph's vertex degrees;  $d_G$  is the diameter of the graph;  $n_E$  – number of edges of the graph.

During signature generation of the malware's behavior based on the tracing of API calls, common to both phases is the categorization of API calls by classes. To generate the signature of malware, all set of critical API calls were divided into 26 classes [11, 12]. Table 1 shows the examples of API calls classes and their description. For example, the DeleteFiles and CreateDirectory functions are defined as Class B, i.e. functions for processing files and directories. If we have sequence API calls with CallNextHookEx, isDebuggerPresent and CreateProcess, then we will receive the following sequence “AFH” as the part of the signature. Mentioned above representation of API calls can compactly store the program's behavior presented by API calls. Additionally, combining API calls into classes of critical actions allows representing a set of functions as a group by their functionality (for example, CreateProcessAsUser and CreateProcess are similar by its executed functions) and can be used for different samples belonging to the same malware family. Furthermore, the process of signature generation and categorization of critical API calls doesn't take into account the function's input parameters and the result of its execution.



**Fig.1.** The signature generation of the malware's behavior based on the tracing of API calls

**Table 1.** API calls classes, their description and examples

API class	Description	Examples of API function	Number of API
Class A	Hooking function	CallNextHookEx, SetWindowsHookEx	12
Class B	File and directory	DeleteFiles, CreateDirectory, CopyFile	242
Class C	System registry	RegCreateKey, RegDeleteValue	48
Class D	Synchronization	CreateMutex, CreateMutexEx	213
...	...	...	...
Class Z	Device management features	DeviceControl, DvdLauncher	24

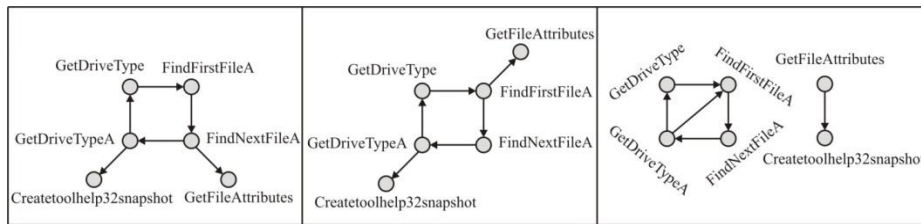
The analysis of the frequency critical API calls allows defining the membership degree - a measure of belongingness of malicious program to a malware class. It will determine the relationship between the malware sample and one of the malware classes in terms of the number of critical API calls. This is a necessity statement for assignment of the suspicious program into one of malware or benign programs classes. However, the analysis of this parameter does not provide information about the nature of the interaction between critical API calls, and, accordingly, it is not possible to refer the suspicious program to a certain modification of the malware, but only to the whole class.

Therefore, the second component of the malware's signature is intended to reflect the nature of the interaction and the relationship of the malware's critical APIs, as it allows separating the malware samples within the class.

To this end, the virus program can be represented as a directed graph  $D$  (1). For example, having the a set of degrees of vertex  $\{3,3,2,2,1,1\}$ , it is possible to construct the following graphs as in fig.2.

Examples of simple graphs demonstrated in fig. 2 with the same degrees of vertex are characterized by the presence of a constant component (connections in the form of a square). Similar patterns can be inherent in malware.

In addition, to distinguish malwares within the class, let us involve two features: the graph diameter and the number of edges. The graph diagram determines the maximum sequence of the critical API calls, while the number of edges determines the total number of actions performed by the malware.



**Fig. 2.** Graphs with same the vertices degrees of a  $\{3,3,2,2,1,1\}$   
(the vertices represent the critical API calls)

### 3.3 Determination of the degree of membership of malicious program to a malware class.

One of the components of the proposed signature is a set of frequencies of the critical API calls. On the basis of this set the definition of the degree of membership of malicious program to a malware class is carried out. Thus, the signature base besides the frequencies of the critical API calls should contain the degree of membership of malicious program to a malware class.

The evaluation process for the degree of membership of malicious program to a malware class is based on the difference between the number of API calls performed by malicious program and benign applications in the process of their own execution. Therefore, the distinguishing between the classes of malicious programs and benign applications is possible by their behavior, that is, by the sequence of critical API calls.

In order to construct the behavior of a malware class  $C_i = \{c_i^1, c_i^2, \dots, c_i^x\}$  on the basis of frequencies of the critical API calls, let us represent the behavior of an malware's sample of this class as a tuple  $(c_i^j - \text{malware's sample of the class } C_i)$ , where  $x$  – the number of malware's samples of the class  $C_i$ :

$$c_i^j = \langle f_1, f_2, \dots, f_{26} \rangle, \quad (3)$$

where  $f_1, f_2, \dots, f_{26}$  – the frequencies of the critical API calls.

Let us group all the frequencies values of the critical API calls  $c_i^j$  ( $\forall c_i^j \in C_i$ ) and represent them in the form of a matrix  $R_{C_i}$ :

$$R_{C_i} = \begin{bmatrix} c_i^1 = \langle f_1, f_2, \dots, f_{26} \rangle \\ c_i^2 = \langle f_1, f_2, \dots, f_{26} \rangle \\ \dots \\ c_i^x = \langle f_1, f_2, \dots, f_{26} \rangle \end{bmatrix}, \quad (4)$$

Based on the formed matrix  $R_{C_i}$ , let us definite the malware's behavior of the class  $C_i$  as the set of mean values of the calls for each of critical API functions class:

$$S_{C_i} = \langle F_1, F_2, \dots, F_{26} \rangle, \quad F_i = \frac{1}{x} \sum_{j=0}^x f_j, \quad (5)$$

where  $j$  is the class of the critical API calls.

On the basis of the received behavior of the malware class  $S_{C_i}$ , the determination of the degree of membership of malicious program to a malware class  $C_i$  is carried out using Chi-square test. The Chi-square test determines the maximum probability of a statistical significance test that measures the difference between proportions in two independent samples.

Then, to obtain the membership degree to class  $C_i$ , with the use of the Chi-square test, the determination of the difference between the proportions in the signature of the malware class  $S_{C_i}$  and each of the samples' behaviors of the  $c_i^j$  with the correction for continuity using the Yates's correction is carried out as follows:

$$\chi_j^2 = \sum_{l=1}^{26} \frac{(|c_{i,l}^j - S_{C_{i,l}}| - 0.5)^2}{S_{C_{i,l}}}, \quad (6)$$

where  $l$  is the corresponding class of critical API calls.

As a result a set of values pairs  $(\chi_i^2, c_i^j)$  is obtained.

The next stage of method involves the determining of the average value of the membership degree to the malware class  $C_i$  using formula:

$$\mu_{C_i} = \frac{1}{x} \sum_{i=1}^x \chi_i^2. \quad (7)$$

Thus, the parameter  $\mu_{C_i}$  determines the membership degree of suspicious sample  $c_i^j$  to malware class and allows evaluating malware relationship within the class  $C_i$ .

### 3.4 Detection of a malicious program represented by signature of program behavior based on API call tracing.

Having the membership degrees  $\mu_{C_i}$  for each of malicious and benign programs to classes  $C_i$  and the constructed signatures  $S_j$  it is possible to perform the suspicious program's detection.

The first step of the proposed method of detection involves determining the membership degree to one of the malicious or benign programs class. For this purpose, using the Chi-square test (7), the difference between the proportions of the frequencies of the critical API calls of a suspicious program (first part of S signature) and the frequency of critical API calls for each class (5) is determined.

As a result, a set of the values of membership degree of the suspicious program to each of the classes is obtained. Then the class with the best matches for the given signature is determined based on the following condition:

$$\min(|\mu_{S_j} - \mu_{C_i}|) \quad (8)$$

where  $\mu_{S_j}$  is the value of the membership degree to each of the  $j$ -th malware classes.

As a result, a class  $C_i$  that corresponds to the suspicious program by the frequency of critical API calls is determined.

The next step of the method involves the search of the virus signature within the class  $C_i$ . Let us consider the second component of the proposed signature (2) and denote it as a features vector  $V$ :

$$V = \langle D, d_G, n_E \rangle = \langle v_1, v_2, \dots, v_{28} \rangle \quad (9)$$

The specified vector consists of 28 numerical attributes, where 26 characters determine the degree of vertex of the graph (each vertex of the graph is determined by the class of critical calls of ARIs), and the last two are the diameter of the graph and the number of edges.

In order to distinguish the suspicious program within a malware classes, the classification of features vector  $V$  is carried out. It allows to assign the suspicious program to one of the virus modifications. As an algorithm of machine learning, a Naive Bayes classifier was chosen, as it is widely used in image recognition, is easy to implement and does not require a large training set [13, 14]. The idea behind a Naive Bayes algorithm is the Bayes' Theorem and the maximum posteriori hypothesis. Bayes theorem finds the probability of an event occurring given the probability of another event that has occurred already. In order to determine the belonging of the features vector  $V$  to

the  $j$ -th modification of the  $i$ -th malware family  $C_{i,j}$  with probability  $P(V | C_{i,j})$ , let's write down Bayes' theorem in the following way.

$$P(C_{i,j} | V) = \frac{P(V | C_{i,j})P(C_{i,j})}{P(V)} \quad (10)$$

The determination of the most probable hypothesis using a posterior maximum is carried out as follows:

$$c = \arg \max_{c \in C_{i,j}} P(C_{i,j}) \prod_{i=1}^{26} P(v_k | C_{i,j}) \quad (11)$$

Thus, the technique of the signature formation for a malware, which is invariant to minor changes, is presented. The malware detection approach via proposed malware's signatures is proposed. It allows not only to distinguish detected malware to proper class, but also to determine its modification.

## 4 Experiments

In order to evaluate the effectiveness of the malware detection based on proposed method, experimental studies were conducted. For this purpose, 280 malware samples received from the VX Heavens resource [15] were used. All malware belongs to the virus families Ramnit, Gammima, Delf, Bifrose and MyDoom of various modifications (Table 2). Except for the virus programs, 74 benign applications were used, which are executable files of the operating system MS Windows© (mspaint, bfsvc, etc.). All malware samples of and utility programs were divided into: the training and testing sets. The training sample set consisted of 81 viral programs and 20 benign programs. The rest of malicious and benign samples were used to conduct the testing.

**Table 2.** Number of samples for each of malware families and benign applications.

		Training set		Testing set	
		Malware variant	Samples	Malware variant	Samples
Malware	Ramnit	a	12	b,c	37
	Bifrose	a	17	ae, aq, bg, bh	33
	Delf	g	13	a, d, f, h, r	41
	MyDoom	c,h	21	a, b, g, f	51
	Gammima	a	18	b, c	37
Benign	Windows app	-	20	-	54

The experiments involved the execution of all the samples and obtaining its API call sequences using API Monitor [16]. The next stage involved the behavior's base formation for all viral classes. For this purpose, for each class, membership degrees were determined using the Chi-square test (3-8). The classification results are presented in the table 3. It shows that the best detection accuracy was shown for the virus programs of the class MyDoom (96,56%) with a false positive values 3,78%. At the same time, the lowest accuracy rate of detection was seen at the level 92,74%, that defines overall accuracy of the proposed technique in the range from 92,74% to

96,56%. It should be noted that in case of wrong assignment of the malware to another modification of the same class, the result of such an experiment was considered as unsuccessful. For example, if the Delf.a virus was classified as a Delf virus class with modification b.

**Table 3.** Classification result

Malware	FPR	FNR	Precision	Recall	Accuracy
Ramnit	<b>1,25%</b>	8,56%	<b>97,25%</b>	<b>96,54%</b>	96,42%
Bifrose	5,12%	4,23%	92,12%	92,54%	93,80%
Delf	3,32%	4,89%	91,45%	91,23%	92,74%
MyDoom	3,78%	3,54%	94,37%	93,28%	<b>96,56%</b>
Gammima	2,74%	<b>3,40%</b>	92,76%	91,61%	93,10%

## 5 Conclusion

The paper presents a method for a malware's signature forming based on API call tracing. Technique allows malware detection using a proposed form of signature. The program's behavior signature based on API call tracing consists of the call frequency and the nature of the interaction of critical API calls. The detection process using the proposed signature enables to distinguish the malicious programs from benign not only by the presence of the critical API calls, but also in their interaction with each other. The experimental results showed that the effectiveness of the malware detection is up to 96.56%.

Presented technique of malware detection using a proposed form of signature has shown good detection accuracy and intended for specialists in the antivirus industry, which are engaged in the analysis of malware and support for antivirus databases. However as a majority of a dynamic approaches our method have some limitations, which are primarily related to the obfuscation and detection evasion techniques employed by the malware authors who try to develop stealth malware. In future we will concentrate to overcome this shortcoming.

## References

1. McAfee Labs Threat Report. December 2018. Availabe: <https://www.mcafee.com/enterprise/en-us/assets/reports/rp-quarterly-threats-dec-2018.pdf>
2. Savenko, O., Lysenko, S., Nicheporuk, A., Savenko, B.: Approach for the Unknown Metamorphic Virus Detection. In: 9-th IEEE International Conference on Intelligent Data Acquisition and Advanced Computing Systems. Technology and Applications, Bucharest, Romania, pp. 453-458 (2017)
3. Savenko, O., Lysenko, S., Nicheporuk, A., Savenko, B.: Metamorphic Viruses' Detection Technique Based on the Equivalent Functional Block Search. CEUR Workshop, Vol. 1844, pp. 555-569 (2017)
4. Pomorova, O., Savenko, O., Lysenko, S., Nicheporuk, A.: Metamorphic viruses detection technique based on the modified emulators. CEUR Workshop, Vol. 1614, pp. 375-383 (2016)

5. Ki, Y., Kim, E., Kim, H.K.: A novel approach to detect malware based on API call sequence analysis. *International Journal of Distributed Sensor Networks - Special issue on Advanced Big Data Management and Analytics for Ubiquitous Sensors*, Vol. 2015 (2015)
6. Wressnegger, C., Freeman, K., Yamaguchi, F., Rieck, K.: Automatically Inferring Malware Signatures for Anti-Virus Assisted Attacks. In: *Proc. of the 2017 ACM on Asia Conference on Computer and Communications Security*, pp. 587-598 (2017)
7. David, O.E., Netanyahu N.S.: Deepsign: Deep learning for automatic malware signature generation and classification.: *International Joint Conference on Neural Networks*, pp. 1-8 (2015)
8. Ndibanje, B., Kim, K.H., Kang, Y.J., Kim, H.H., Kim, T.Y., Lee, H.J.: Cross-Method-Based Analysis and Classification of Malicious Behavior by API Calls Extraction. *Applied Sciences*, Vol. 9 (2), pp. 1-15 (2019)
9. Gupta, S., Sharma, H., Kaur, S.: Malware Characterization Using Windows API Call Sequences: In *Proc. of the Sixth International Conference on Security, Privacy and Applied Cryptographic Engineering*, (2016)
10. Lysenko, S., Savenko, O., Bobrovnikova, K., Kryshchuk, A., Savenko, B.: Information technology for botnets detection based on their behaviour in the corporate area network. *Communications in Computer and Information Science*, Vol.718, pp. 166-181 (2017)
11. Windows Developer Center, <https://msdn.microsoft.com/en-us/windows>
12. Lim, H.: Detecting Malicious Behaviors of Software through Analysis of API Sequence k-grams.: *Computer Science and Information Technology*, Vol. 4 (3), pp. 85-91 (2016)
13. Mansour, A.M.: Texture Classification using Naïve Bayes Classifier: *International Journal of Computer Science and Network Security*, Vol.18, No.1, pp. 112-120 (2018)
14. Brad, G.V.: Uses and misuses of Bayes' rule and Bayesian classifiers in cybersecurity. In *Proc. of the 43-rd International Conference Applications of mathematics in engineering and economics*, pp. 1-8 (2017)
15. VX Heavens Computer virus collection. Availabe: <http://vx.netlux.org>
16. API Monitor. Availabe: <http://www.rohitab.com/apimonitor>



# On-Line Checking of Faults in Cyber-Physical Systems

Volodymyr G. Skobelev<sup>[0000-0002-7018-2319]</sup> and  
Volodymyr V. Skobelev<sup>[0000-0003-1581-3859]</sup>

Glushlov Institute of Cybernetics of NAS of Ukraine,  
Glushkov Ave., 40, Kyiv, 03187, Ukraine  
[skobelevvg@gmail.com](mailto:skobelevvg@gmail.com)

**Abstract.** Numerous applications of cyber-physical systems in safety-critical spheres of human activity are the main reason for the fact that the development of methods intended for on-line faults diagnoses in these systems is one of the actual problems. One of the essential sub-problems for this problem is elaboration of models and methods intended for on-line checking of faults in cyber-physical systems. In the given paper this sub-problem is investigated under the supposition that these systems can be modeled by the 1-dimensional hybrid automata defined in the given paper. On the base of this model-based approach, some completely distributed system intended for on-line monitoring and fault components isolation in cyber-physical systems is proposed. This system consists of controllers of two types. Controllers of the first type are intended for checking the dynamics of physical processes, while controllers of the second type are intended for checking switching between dynamics. The structure of both types of proposed controllers is considered in detail. Necessary and sufficient conditions that guarantee for both types of proposed controllers that they carry out correct on-line checking are established and proved.

**Keywords:** Hybrid automata · Faults · On-line checking.

## 1 Introduction

Modern information technologies have stimulated penetration of cyber-physical systems (CPS) into different spheres of mankind activity. Informally, any CPS (see [1], for example) consists of some computer networks and/or built-in controllers that are used for control of considered physical processes via the feedback, i.e. the considered physical processes conduct the computations, while the computations, in its turn, conduct the choice and the mode of these physical processes. The state of the art in the development of CPS is presented in [2,3].

At present, CPS are widely used at the research of the Space, in power, military, transport, healthcare, and production spheres, for the design of modern infrastructure, etc. By this reason, in the overwhelming majority of cases, these domains are critical ones. Therefore, in the vast majority of cases, CPS are

safety-critical systems. For this reason, the development of methods intended for faults diagnoses in CPS is one of the actual problems. Different approaches for investigation of this problem have been presented in [4–6].

The essential sub-problem for the problem of on-line faults diagnoses in CPS is the problem of on-line monitoring and fault components isolation in these systems. The given paper is devoted to the investigation of this problem.

We propose some model-based completely distributed system intended for on-line monitoring and fault components isolation in the analyzed CPS. This system consists controllers of two types. Controllers of the first type are intended for checking the dynamics of physical processes in the analyzed CPS, while controllers of the second type are intended for checking switching between dynamics in the analyzed CPS.

## 2 Mathematical Backgrounds

It is well-known that hybrid automata (HA) are one of the most often used mathematical models for the design of formal specification and the analysis of CPS. Therefore, it is natural to develop any model-based algorithms or systems intended for analysis of CPS in terms of HA.

One of the first definitions for HA has been proposed in [7]. Although this definition of HA provides to us a convenient conceptual model, it is very difficult to apply this model for the development of algorithms for CPS. Indeed, at the solution of specific problems for CPS by means of these or those software tools, the researcher, as the rule, must predetermine, detail and reformulate analyzed objects and concepts in such way that the received model can be very problematically squeezed in this definition of HA.

For the development of algorithms for analysis of CPS, much more convenient and much more widely used is the model of HA defined in [8] in the following way.

An HA is a system

$$\mathcal{H} = (Q, X, I, D, f, E, G, R),$$

where:

- $Q$  is a finite set of discrete states;
- $X \subseteq \mathbb{R}^n$  is a set of continuous states;
- $f : Q \times X \rightarrow \mathbb{R}^n$  is vector field;
- $I \subseteq Q \times X$  is a set of initial states;
- $D : Q \rightarrow \mathcal{B}(X)$  is a domain;
- $E \subseteq Q \times Q$  is a set of edges;
- $G : E \rightarrow \mathcal{B}(X)$  is a guard condition;
- $R : E \times X \rightarrow \mathcal{B}(X)$  is a reset map.

It is well-known that there is a considerable number of difficulties connected with computations and algorithmic solvability for such general model of HA. By this reason, at the resolving of specific problems for CPS, the researchers take

this circumstance into consideration and usually limit themselves to the analysis of sufficiently narrow sets of HA.

Due to this approach, we investigate the problem of checking of faults in CPS under the assumption that the associated model of HA is an element of the set  $H_0$  of 1-dimensional HA that has been defined and investigated in [9].

This set  $H_0$  of 1-dimensional HA has been defined proceeding from the model of HA offered in [8], as follows.

It is assumed that for each discrete state  $q \in Q$  the following six conditions hold:

1. The set  $D(q) = X_q \subseteq X$  is some finite interval.
2. The set of initial values of the continuous state is the set of pair-wise disjoint closed intervals  $[\alpha_{q,h}, A_{q,h}]$  ( $\alpha_{q,h} \leq A_{q,h}$ ), where  $h = 1, \dots, r_q$ .
3. The guard condition associated with the set of initial values  $[\alpha_{q,h}, A_{q,h}]$  ( $h = 1, \dots, r_q$ ) is some closed interval  $[\beta_{q,h}, B_{q,h}]$  ( $\beta_{q,h} \leq B_{q,h}$ ), and the sets  $[\beta_{q,h}, B_{q,h}]$  ( $h = 1, \dots, r_q$ ) are pair-wise disjoint.
4. For each set  $[\alpha_{q,h}, A_{q,h}]$  ( $h = 1, \dots, r_q$ ) of initial values the dynamics is presented by the differential equation  $\dot{x} = f_{q,h}(x)$ , where  $Dom(f_{q,h}) \supseteq X_q$  and  $f_{q,h}$  is some Lipschitz continuous function.
5. For each set  $[\alpha_{q,h}, A_{q,h}]$  ( $h = 1, \dots, r_q$ ) of initial values the duration of the dynamics is some number  $t_{q,h} \in [\theta_{q,h}, \Theta_{q,h}]$  (where either  $\theta_{q,h} = \Theta_{q,h} = 0$ , or  $0 < \theta_{q,h} < \Theta_{q,h}$ ), such that  $x(t_{q,h}) \in [\beta_{q,h}, B_{q,h}]$ .
6. For each guard condition  $[\beta_{q,h}, B_{q,h}]$  ( $h = 1, \dots, r_q$ ) there exists the single arc  $(q, q') \in E$  and the single set  $[\alpha_{q',m}, A_{q',m}]$  ( $m \in \{1, \dots, r_{q'}\}$ ) of initial values, such that the inclusion  $R_{(q,q')}([\beta_{q,h}, B_{q,h}]) \subseteq [\alpha_{q',m}, A_{q',m}]$  holds, where  $R_{(q,q')}(\cdot) = R((q, q'), \cdot)$ .

It should be noted that when the condition  $\theta_{q,h} = \Theta_{q,h} = 0$  holds, de facto we deal not with the continuous dynamics, but with usual switching. Besides, it is more correct to use denotation  $((q, h), (q', m))$  for the elements of the set  $E$ . This denotation will be used in what follows.

The set  $H_0$  has been called the set of 1-dimensional HA, since each dynamics is presented by a differential equation from the same variable, though the number the different dynamics in discrete states can be different. The main aim to define this set of HA has been to aggregate the discrete states of HA, and thus to simplify structure of the transition graph due to reduction the number of vertices.

Let  $S_{q,h}^{in}$  and  $S_{q,h}^{fin}$  be the maximal relatively to the inclusion relation sets that are defined by the following three axioms:

- (i)  $S_{q,h}^{in} \subseteq [\alpha_{q,h}, A_{q,h}] \& S_{q,h}^{fin} \subseteq [\beta_{q,h}, B_{q,h}]$ ;
- (ii)  $\theta_{q,h} = \Theta_{q,h} = 0 \Rightarrow S_{q,h}^{in} = S_{q,h}^{fin}$ ;
- (iii)  $0 < \theta_{q,h} < \Theta_{q,h} \Rightarrow (\forall x(t))(x(0) \in S_{q,h}^{in} \Rightarrow \Rightarrow (\exists t_0 \in [\theta_{q,h}, \Theta_{q,h}]) (x(t_0) \in S_{q,h}^{fin}) \& (\forall t \in [0, \Theta_{q,h}]) (x(t) \in X_q)) \&$

$$\&(\forall b \in S_{q,h}^{fin})(\exists x(t))(x(0) \in S_{q,h}^{in} \& (\exists t_0 \in [\theta_{q,h}, \Theta_{q,h}])(x(t_0) = b)).$$

It has been proved in [9] that each HA  $\mathcal{H} \in H_0$  can be reduced to equivalent model, such that the following two conditions hold:

*Condition 1.* The equalities

$$S_{q,h}^{in} = [\alpha_{q,h}, A_{q,h}]$$

and

$$S_{q,h}^{fin} = [\beta_{q,h}, B_{q,h}]$$

are true for all  $q \in Q$  and  $h = 1, \dots, r_q$ .

*Condition 2.* The equality

$$R_{((q,h),(q',m))}(S_{q,h}^{fin}) = S_{q',m}^{in}$$

is true for all  $((q,h),(q',m)) \in E$ .

In what follows it is supposed that the Conditions 1 and 2 hold for any considered HA.

### 3 Main Results

It is evident that different architectures for the system of on-line checking of faults in CPS can be offered. The main criteria of the efficiency for this system are the reliability, the scalability, and the minimal time for decision-making.

Due to these criteria, the best solution is the completely distributed system for on-line checking of faults in CPS. Thus, for each dynamical process, as well as for each switching its own controller can be associated.

It should be emphasized that we consider the controller as some discrete electronic device implemented on the base of the microprocessor and RAM.

Let us characterize these controllers for CPS presented by HA  $\mathcal{H} \in H_0$ .

#### 3.1 On-Line Checking of Continuous Dynamics

It is assumed that if any of physical processes in the analyzed CPS is not activated after obtaining the relevant input data, then the special physical device instantly blocks this process. Thus, we will deal with the situation when each physical process in the analyzed CPS is activated after obtaining the relevant input data.

It is also assumed that the controllers which are carrying out on-line checking of different dynamical processes in the analyzed CPS are different, and do not interact with each other in any way. Therefore, considering the HA  $\mathcal{H} \in H_0$  associated with the analyzed CPS, we conclude that the total number of controllers intended for on-line checking of different dynamical processes in the analyzed CPS does not exceed the integer  $\sum_{q \in Q} r_q$ .

Now we define the controller

$$\mathcal{C}_{q,h} \quad (q \in Q; h \in \{1, \dots, r_q\}),$$

which for the fixed discrete state  $q \in Q$  of HA  $\mathcal{H} \in H_0$  carries out on-line checking of the continuous dynamics for the analyzed CPS, under assumption that this dynamics is presented in the HA  $\mathcal{H}$  by the differential equation

$$\dot{x} = f_{q,h}(x) \quad , \quad (1)$$

where  $f_{q,h}$  is, at least, some Lipschitz continuous function on the closed interval  $[0, \Theta_{q,h}]$ .

It should be noted that this assumption about the function  $f_{q,h}$  holds for sufficiently wide class of CPS.

Applying the Euler method, we can transform the equation (1) into the finite-difference equation

$$x_{j+1} = x_j + f_{q,h}(x_j) \cdot \Delta t \quad (j = 0, 1, \dots), \quad (2)$$

where  $\Delta t = L_{q,h}^{-1} \cdot \Theta_{q,h}$ , and  $L_{q,h}$  is some suitably chosen sufficiently large positive integer. It is also assumed that there exists positive integer  $l_{q,h}$  ( $l_{q,h} < L_{q,h}$ ), such that the identity  $\theta_{q,h} = l_{q,h} \cdot \Delta t$  holds. This assumption does not restrict the reasoning, but simplifies the presentation.

Therefore, with each solution  $x(t)$  of the differential equation (1) can be associated the sequence

$$x_0, x_1, \dots \quad (x_0 = x(0)), \quad (3)$$

calculated in accordance with the formula (2).

The controller  $\mathcal{C}_{q,h}$  ( $q \in Q; h \in \{1, \dots, r_q\}$ ) consists of the two blocks, namely  $B_1$  and  $B_2$ .

The block  $B_1$  consists of two input channels, namely  $i_{1,1}$  and  $i_{1,2}$ , and one output channel, namely  $o_1$ .

The input channel  $i_{1,1}$  obtains from some sensor the information that the initial value for the analyzed physical process in CPS is  $x_0$ .

The input channel  $i_{1,2}$  is a binary channel. It obtains through some sensor the information whether the analyzed physical process in CPS presented by the differential equation (1) in the HA is activated or is not activated.

It is assumed that the symbol 1 is associated with the situation that analyzed physical process in the analyzed CPS is activated, the symbol 0 is associated with the situation that this physical process is not activated, the impulse  $0 \rightarrow 1$  activates the block  $B_1$  and the impulse  $1 \rightarrow 0$  deactivates this block.

As soon as the block  $B_1$  is activated, it carries out calculation of the sequence (3) sequentially, symbol by symbol.

It is assumed that the symbol  $x_0$  and each calculated symbol  $x_j$  ( $j = 1, 2, \dots$ ) at once appears on the output channel  $o_1$  of the block  $B_1$ .

The block  $B_2$  consists of three input channels, namely  $i_{2,1}$ ,  $i_{2,2}$  and  $i_{2,2}$ , and one output channel, namely  $o_2$ .

The input channel  $i_{2,1}$  is identical with the input channel  $i_{1,2}$ . Thus, the input channels  $i_{2,1}$  and  $i_{1,2}$  can be treated as the branching of the same line connected with the same sensor.

Similarly, to destination of the input channel  $i_{1,2}$ , the input channel  $i_{2,1}$  activates the block  $B_2$  by the impulse  $0 \rightarrow 1$ .

The input channel  $i_{2,2}$  of the block  $B_2$  is connected with the output channel  $o_1$  of the block  $B_1$ .

The input channel  $i_{2,3}$  of the block  $B_2$  obtains from some sensor, symbol by symbol, the information that the analyzed physical process generates the sequence

$$y_0, y_1, \dots \quad (y_0 = x_0)$$

of its output values.

The output channel  $o_2$  of the block  $B_2$  is a binary channel connected with the physical device  $\mathcal{D}_{q,h}$  that can immediately deactivate and isolate the analyzed physical process in CPS.

It is assumed that the symbol 1 is associated with the situation when the device  $\mathcal{D}_{q,h}$  must be activated and the symbol 0 is associated with the situation when this device is deactivated.

As soon as the block  $B_2$  is activated, the value of the signal on its output channel  $o_2$  is equal to 0.

When the block  $B_2$  obtains the symbols  $x_j$  and  $y_j$ , respectively, on its input channels  $i_{2,2}$  and  $i_{2,3}$ , where  $j = 1, 2, \dots$ , it carries out the following calculations.

The block  $B_2$  computes the value

$$t_j = t_{j-1} + \Delta t \quad (t_0 = 0),$$

and checks whether the inequality

$$t_j \leq \Theta_{q,h}$$

holds.

Let

$$t_j > \Theta_{q,h}$$

and the value of the signal on the input channel  $i_{2,1}$  is equal to 1. Then the signal 1 is generated on the output channel  $o_2$  of the block  $B_2$ , and the block  $B_2$  deactivates itself.

Let

$$t_j \leq \Theta_{q,h}$$

and the value of the signal on the input channel  $i_{2,1}$  is equal to 1. Then the block  $B_2$  checks, whether the condition

$$y_j \in X_q$$

holds.

Suppose, that this condition is violated. Then the signal 1 is generated on the output channel  $o_2$  of the block  $B_2$ , and the block  $B_2$  deactivates itself.

Otherwise (i.e. when the condition  $y_j \in X_q$  holds), the condition

$$|x_j - y_j| \leq \varepsilon$$

is checked, where  $\varepsilon$  is some sufficiently small properly chosen positive number.

If this condition is violated, then the signal 1 is generated on the output channel  $o_2$  of the block  $B_2$ , and the block  $B_2$  deactivates itself.

Let

$$t_j \leq \Theta_{q,h}$$

and the impulse  $1 \rightarrow 0$  is applied to the input channel  $i_{2,1}$  of the block  $B_2$ . Then this block checks whether the inequality

$$t_j \geq \theta_{q,h}$$

holds.

If  $t_j < \theta_{q,h}$  then the signal 1 is generated on the output channel  $o_2$  of the block  $B_2$ , and the block  $B_2$  deactivates itself.

Otherwise (i.e. when  $t_j \geq \theta_{q,h}$ ), the block  $B_2$  deactivates itself.

It is evident that the time spent by the block  $B_2$  on the considered above calculations is insignificant in the comparison with the time spent by the block  $B_1$  on its calculations. By this reason, the time spent by the block  $B_2$  on the considered above calculations can be neglected at all.

Therefore, it can be assumed that the calculations of the block  $B_2$  are carried out instantly.

The controller  $\mathcal{C}_{q,h}$  ( $q \in Q; h \in \{1, \dots, r_q\}$ ) offered above can be characterized as follows.

**Theorem 1.** *It can be guaranteed that the controller*

$$\mathcal{C}_{q,h} \quad (q \in Q; h \in \{1, \dots, r_q\})$$

*carries out correct on-line checking of the analyzed physical process in the analyzed CPS if and only if the equality*

$$T_{B_1} = T_{B_2} \tag{4}$$

*holds, where  $T_{B_1}$  is the time necessary for the block  $B_1$  to calculate any value  $x_j$  ( $j \in \{0, 1, \dots, L_{q,h}\}$ ) and  $T_{B_2}$  is the time necessary for the block  $B_2$  to obtain from some sensor any value  $y_j$  ( $j \in \{0, 1, \dots, L_{q,h}\}$ ).*

*Proof.* Let us suppose that the equality (4) holds.

From the definition of the controller  $\mathcal{C}_{q,h}$  ( $q \in Q; h \in \{1, \dots, r_q\}$ ) we get that if this controller is activated then on the input channels  $i_{2,2}$  and  $i_{2,3}$  of the block  $B_2$  the signals  $x_j$  and  $y_j$ , associated to each other, are obtained in each instant of time.

Besides, from the definition of the block  $B_2$  it follows that the signal 1 can be produced on its output channel  $o_2$  if and only if this block is activated, and some fault in the analyzed physical process in the analyzed CPS reveals itself

at the current instant of time. In this case the device  $\mathcal{D}_{q,h}$  is activated, and the analyzed physical process in the analyzed CPS is deactivated and isolated.

Thus, it can be guaranteed that the controller  $\mathcal{C}_{q,h}$  ( $q \in Q; h \in \{1, \dots, r_q\}$ ) carries out correct on-line checking of the analyzed physical process in the analyzed CPS.

Let us suppose that the equality (4) isn't met, i.e. the inequality

$$|T_{B_1} - T_{B_2}| > 0$$

holds.

From the definition of the controller  $\mathcal{C}_{q,h}$  ( $q \in Q; h \in \{1, \dots, r_q\}$ ) it follows that if this controller is activated then there can exist some instant of time such that on the input channels  $i_{2,2}$  and  $i_{2,3}$  of the block  $B_2$  are obtained the signals  $x_{j_1}$  and  $y_{j_2}$ , where  $j_1 \neq j_2$ . Starting from this instant of time the functioning of the controller  $\mathcal{C}_{q,h}$  ( $q \in Q; h \in \{1, \dots, r_q\}$ ) can be incorrect.

Thus, there is no guarantee that the controller  $\mathcal{C}_{q,h}$  ( $q \in Q; h \in \{1, \dots, r_q\}$ ) carries out correct on-line checking of the analyzed physical process in the analyzed CPS.

Q.E.D.

### 3.2 On-Line Checking of Switching

It is assumed that with each switching between dynamics in the analyzed CPS its own controller is associated, and different non-interacting with each other controllers are associated with different switching. Therefore, there is a one-to-one correspondence between non-interacting controllers intended for on-line checking of switching between dynamics in the analyzed CPS and the elements of the set  $E$  in the associated HA  $\mathcal{H} \in \mathbf{H}_0$ , i.e. the total number of these controllers is equal to  $|E|$ .

It is also assumed that for the analyzed CPS the time needed to carry out any switching between dynamics is some sufficiently small positive number  $\tau$ . This assumption reflects the fact that in real systems switching are made not instantly, but with some delay.

Now we define the controller

$$\mathcal{C}_{((q,h),(q',m))} \quad (q, q' \in Q; h \in \{1, \dots, r_q\}; m \in \{1, \dots, r_{q'}\}),$$

intended for on-line checking of switching in the analyzed CPS, defined by the arc  $((q, h), (q', h')) \in E$  in the associated HA  $\mathcal{H} \in \mathbf{H}_0$ .

The controller  $\mathcal{C}_{((q,h),(q',m))}$  consists of three input channels  $i_1, i_2, i_3$  and one output channel  $o$ .

The input channel  $i_1$  of the controller  $\mathcal{C}_{((q,h),(q',m))}$  is a binary channel, and through some sensor obtains the information whether the physical process in the analyzed CPS, associated with the dynamics  $\dot{x} = f_{q,h}(x)$  in the HA  $\mathcal{H}$ , is activated or is not activated.

It is assumed that the symbol 1 is associated with the situation when the physical process in the analyzed CPS, associated with the dynamics  $\dot{x} = f_{q,h}(x)$



in the HA  $\mathcal{H}$ , is activated, the symbol 0 is associated with the situation when this process is deactivated, and the impulse  $1 \rightarrow 0$  activates the controller  $\mathcal{C}_{((q,h),(q',m))}$ .

The input channel  $i_2$  of the controller  $\mathcal{C}_{((q,h),(q',m))}$  is connected with the output channel of the block  $B_1$  of the controller  $\mathcal{C}_{q,h}$ , which is intended for on-line checking of the dynamics  $\dot{x} = f_{q,h}(x)$ , and obtains, symbol by symbol, the sequence

$$x_0, x_1, \dots, x_{t_{q,h}}$$

computed by this block.

The input channel  $i_3$  of the controller  $\mathcal{C}_{((q,h),(q',m))}$  through some sensor obtains, symbol by symbol, the values

$$y_0, y_1, \dots, y_{t_{q,h}}$$

produced by the physical process in the analyzed CPS, associated with the dynamics  $\dot{x} = f_{q,h}(x)$  in the HA  $\mathcal{H}$ .

The output channel  $o$  of the controller  $\mathcal{C}_{((q,h),(q',m))}$  is a binary channel connected with the physical device  $\mathcal{S}_{((q,h),(q',m))}$ . This device carries out in the analyzed CPS the switching between the physical process associated with the dynamics  $\dot{x} = f_{q,h}(x)$  in the HA  $\mathcal{H}$  and the physical process associated with the dynamics  $\dot{x} = f_{q',m}(x)$  in the HA  $\mathcal{H}$ .

It is assumed that the symbol 1 on the output channel  $o$  of the controller  $\mathcal{C}_{((q,h),(q',m))}$  is associated with the situation when the device  $\mathcal{S}_{((q,h),(q',m))}$  is activated, and the symbol 0 is associated with the situation when this physical device is deactivated.

It is also assumed that initially the value of the signal on the output channel  $o$  of the controller  $\mathcal{C}_{((q,h),(q',m))}$  is equal to 1.

In the instance of time when the impulse  $1 \rightarrow 0$  is applied to the input channel  $i_1$ , the values of the symbols on the input channels  $i_2$  and  $i_3$  are equal to  $x_{t_{q,h}}$  and  $y_{t_{q,h}}$  respectively, where  $t_{q,h} \in [\theta_{q,h}, \Theta_{q,h}]$ .

The controller  $\mathcal{C}_{((q,h),(q',m))}$  is activated, and carries out checking of the truth value of the following condition

$$\begin{aligned} & |x_{t_{q,h}} - y_{t_{q,h}}| \leq \varepsilon \& y_{t_{q,h}} \in [\beta_{q,h}, B_{q,h}] \& \\ & \& R(((q, h), (q', m)), y_{t_{q,h}}) \in [\alpha_{q',m}, A_{q',m}], \end{aligned} \quad (5)$$

where  $\varepsilon$  is some sufficiently small positive number designating the size of admissible absolute difference between the associated with each other the model and the real values of the analyzed physical process in the CPS.

If the condition (5) holds then the value of the signal on the output channel  $o$  of the controller  $\mathcal{C}_{((q,h),(q',m))}$  remains be equal to 1, and a violation of this condition changes this value on 0.

The controller  $\mathcal{C}_{((q,h),(q',m))}$  offered above can be characterized as follows.

**Theorem 2.** *It can be guaranteed that the controller*

$$\mathcal{C}_{((q,h),(q',m))} \quad (q, q' \in Q; h \in \{1, \dots, r_q\}; m \in \{1, \dots, r_{q'}\})$$

carries out correct on-line checking of the switching in the analyzed CPS, defined by the arc  $((q, h), (q', h')) \in E$  in the HA  $\mathcal{H} \in \mathbf{H}_0$ , if and only if the inequality

$$T_{|x-y| \leq \varepsilon} + T_{y \in [\beta_{q,h}, B_{q,h}]} + T_R < \tau \quad (6)$$

is true, where  $T_{|x-y| \leq \varepsilon}$  is the time necessary for checking the condition  $|x-y| \leq \varepsilon$ ,  $T_{y \in [\beta_{q,h}, B_{q,h}]}$  is the time necessary for checking the condition  $y \in [\beta_{q,h}, B_{q,h}]$ ,  $T_R$  is the total time necessary for calculating the value  $z = R(((q, h), (q', m)), y)$  and checking the condition  $z \in [\alpha_{q',m}, A_{q',m}]$ , and  $\tau$  is the time necessary for the physical device  $\mathcal{S}_{((q,h),(q',m))}$  to carry out switching between dynamics in the analyzed CPS.

*Proof.* Let us suppose that the inequality (6) holds.

From the definition of the controller  $\mathcal{C}_{((q,h),(q',m))}$  we get that at the instance when this controller is activated, the symbols on its input channels  $i_2$  and  $i_3$  are equal to  $x_{t_{q,h}}$  and  $y_{t_{q,h}}$  respectively, where  $t_{q,h} \in [\theta_{q,h}, \Theta_{q,h}]$ , and the value of the signal on the output channel  $o$  of the controller  $\mathcal{C}_{((q,h),(q',m))}$  is equal to 1.

Besides, from the definition of the controller  $\mathcal{C}_{((q,h),(q',m))}$  it follows that the signal 0 can be produced on its output channel  $o$  if and only if this controller is activated, and some fault in the analyzed physical process in CPS reveals itself. In this case the physical device  $\mathcal{S}_{((q,h),(q',m))}$  is deactivated.

Due to the inequality (6), the deactivation of the physical device  $\mathcal{S}_{((q,h),(q',m))}$  is occurred in time, smaller than  $\tau$ , and the analyzed switching in the analyzed CPS is blocked.

Thus, it can be guaranteed that the controller  $\mathcal{C}_{((q,h),(q',m))}$  carries out correct on-line checking of the analyzed switching in the analyzed CPS.

Let us suppose that the inequality (6) is false, i.e. the inequality

$$T_{|x-y| \leq \varepsilon} + T_{y \in [\beta_{q,h}, B_{q,h}]} + T_R \geq \tau$$

holds.

From the definition of the controller  $\mathcal{C}_{((q,h),(q',m))}$  it follows that it is possible such situation that some fault reveals itself on the controller  $\mathcal{C}_{((q,h),(q',m))}$  on the expiration of time  $\tau$ . In this case the physical device  $\mathcal{S}_{((q,h),(q',m))}$  is deactivated later than in the analyzed CPS has occurred, perhaps incorrect, switching between the considered physical processes.

Thus, there is no guarantee that the controller  $\mathcal{C}_{((q,h),(q',m))}$  carries out correct on-line checking of the analyzed switching in the analyzed CPS.

Q.E.D.

## 4 Conclusions

The given paper is a theoretic one. Its main aim consisted in the developing some structure of a completely distributed system intended for on-line monitoring and fault components isolation in CPS. The proposed system is developed on the model-based approach under the supposition that 1-dimensional HA of special

type is used as the mathematical model for the analyzed CPS. The use for the analyzed CPS of different controllers for checking the dynamics of physical processes and for checking switching between dynamics, gave the possibility to establish the necessary and sufficient conditions guaranteeing correct on-line checking of faults in the analyzed CPS.

The detailed analysis of the structure of these controllers shows that the offered completely distributed system intended for on-line monitoring and fault components isolation in CPS can be easily generalized on the more general case of CPS, when multi-dimensional HA are used. To achieve this aim, it is sufficient to demand that the restrictions on the time spent by the controllers on their calculations that are similar to the restrictions that have been established in theorems 1 and 2 were carried out.

The main direction of further researches is the specification of the proposed general completely distributed system for on-line monitoring and fault components isolation in specific CPS.

## References

1. Lee, E.A.: Cyber physical systems: design challenges. In: Proceedings of the 11<sup>th</sup> IEEE International Symposium on Object Oriented Real-Time Distributed Computing, pp. 363–369. Orlando, FL, USA (2008)
2. Gunes, V., Peter, S., Givargis, T., and Vahid, F.: A survey on concepts, applications, and challenges in cyber-physical systems. *KSII Transactions on Internet and Information Systems*, **8**(12), 4242–4268 (2014)
3. Liu, Y., Peng, Y., Wang, B., Yao, S., and Liu, Z.: Review on cyber-physical systems. *IEEE/CAA Journal of Automatica Sinica*, **4**(1), 27–40 (2017)
4. Asadollah, S.A., Inam, H., and Hansson, H.: A survey on testing for cyber physical system. In: Proceedings of IFIP International Conference "Testing Software and Systems", pp. 194–207. Sharjah and Dubai, United Arab Emirates (2015)
5. Gao, Z., Ding, S.X., and Cecati C.: Real-time fault diagnosis and fault-tolerant control. *IEEE Transactions on Industrial Electronics*, **62**(6), 3752–3756 (2015)
6. Severson, K., Chaiwatanodom P., and Braatz, R.D.: Perspectives on process monitoring of industrial systems. *Annual Reviews in Control*, **42**, 190–200 (2016)
7. Henzinger, T.A.: The theory of hybrid automata. In: Proceedings of the 11<sup>th</sup> Annual IEEE Symposium on Logic in Computer Science, pp. 278–292. New Brunswick, NJ, USA (1996)
8. Lygeros, J.: Lecture notes on hybrid systems. University of Cambridge, Cambridge (2004). <https://fenix.tecnico.ulisboa.pt/downloadFile/3779579688470/lygeros.pdf>.
9. Skobelev, V.V., and Skobelev, V.G.: Some problems of analysis of hybrid automata. *Cybernetics and Systems Analysis*, **54**(4), 517–526 (2018)

# Ensuring the Security of the Full Logistics Supply Chain Based on the Blockchain Technology

Igor Shostak<sup>1</sup>[0000-0002-3051-0488], Yashar Rahimi<sup>1</sup>[0000-0002-5468-9726], Mariia Danova<sup>1</sup>[0000-0002-8116-8598], Olena Feoktystova<sup>1</sup>[0000-0001-8490-3108] and Olga Melnyk<sup>2</sup>[0000-0002-9671-108X]

<sup>1</sup> National Aerospace University “Kharkiv Aviation Institute”, Chkalova Str. 17, 61070 Kharkiv, Ukraine

<sup>2</sup> National University of Civil Defence of Ukraine, Chernyshevska Str. 94, 61023 Kharkiv, Ukraine

iv.shostak@gmail.com, rahimi.yashar@gmail.com,  
danovamariya@gmail.com, e.i.shostak@gmail.com,  
melnyk.olja.2014@gmail.com

**Abstract.** Issues related to ensuring the security of the functioning of the full logistic supply chain of dried fruit (SCDF) in Ukraine are considered. It is shown that the creation and function of the SCDF, compared to other supply chain management (SCM) class systems, raises a number of specific problems caused by the complexity of the interaction of raw material suppliers (fresh fruit), manufacturers of final products (drying, packaging), storage terminals, distributors, 3PL and 4PL providers (retailers). These problems are due to the fact that the interaction of participants in business processes in the SCDF generates a lot of material, financial and information flows, as well as flows of services from sources of raw materials to the final consumer. An important aspect of improving the performance of the SCDF is the development of methods and tools, and on their basis the applied information technology to ensure the reliability and security of the SCDF. To solve this problem, it was proposed to use the Blockchain technology to protect the telecommunication channels connecting the circuit elements from unauthorized access. The method of identification and authentication of digital objects of the SCDF, which guarantee the security of SCDF elements and provide them with the necessary level of confidentiality, is described.

**Keywords:** Full Logistics Supply Chain, Security of the IoT-Objects, Blockchain, Authentication of IoT-Objects.

## 1 Introductions

A typical example of a complete logistics chain is the supply chain of dry fruit to Ukraine (SCDF). SCDF is a complex socio-economic system consisting of many suppliers of raw materials (fresh fruit), manufacturers of final products (drying, packaging), storage terminals, distributors, 3PL and 4PL providers who have certain resources [1, 2]. The interaction of the participants of business processes in the SCDF is

reflected by the multitude of material, financial and information flows, as well as the flows of services from sources of raw materials to the final consumer. These features determine the specifics of this subject area, namely, a relatively large number of participants in business processes and, accordingly, the complexity of the telecommunication structure of SCDF. Due to this circumstance, there are increased risks of unauthorized access to the SCDF communication channels by competitors. The variety of world regions from which dried fruit is delivered to Ukraine, a wide range of products supplied, yield, currency fluctuations, seasonality are the causes of a high level of uncertainty in the processes of formation and decision-making by the SCDF participants [3].

These circumstances determine the lack of effectiveness of the existing SCDF and dictate the need to modernize it by expanding the concept of supply chain management (SCM) [4] by supplementing it with Internet of Things (IoT) objects, which will make it possible to achieve a conjunctive consensus between all elements of the SCDF in its functioning [5, 6].

A prerequisite for effective management of SCDFs is coordination of joint activities of SCDF participants and synchronization of their business processes, which ultimately is achieved by increasing efficiency: formulating goals and objectives of SCDFs, developing an action strategy based on in-depth and comprehensive analysis of the supply market (including the requirements of a specific customer) and the current state of the supply chain of dried fruit in Ukraine. The fulfillment of this condition is possible only if the appropriate level of protection of digital objects, which are part of the supply chain, is ensured from unauthorized access [7 - 9].

The purpose of the article is to present an approach to ensuring the security of digital objects in the SCDF, presented in the form of IoT, based on a special procedure involving the integrated use of certain software platforms within Blockchain technologies.

## **2 Ensuring the Protection of IoT Objects that are Part of the SCDF**

Security and confidentiality is part of the measures that guarantee the reliable operation of connected IoT objects and compliance with regulatory requirements for the functioning of SCDF. The proper level of security for the operation of the SCDF is determined, in particular, by the high level of protection from unauthorized access to digital objects of chain represented in the form of IoT. The most important is the protection of such objects in the modes of identification and authentication. Identification of the Internet of Things Objects (IDoT) is a task area for assigning unique identifiers and associated metadata to the Internet of Things objects, which allows them to exchange information with other entities on the Internet [10, 11].

All IoT objects in the SCDF must be registered under unique and, very importantly, constant identifiers that are assigned at the level of the control center (focal company), and each identifier must correspond to a set of metadata - detailed information about the IoT object determined depending on context of the functioning

of the object in the composition of the SCDF. At the same time, the set of metadata itself is essentially a digital object with a clear structure. Thus, the identification and authentication of digital objects that exist in the SCDF, require the development of special algorithms, since such objects must be identified and managed. When sending confidential information, sureness in the protection of information from unauthorized use or disclosure by competitors is required [12, 13].

When building a SCDF with IoT elements, there are two key security components: the integrity and authenticity of the software of IoT objects, that is, only the software that was allowed to work on this device is loaded; authentication of IoT objects before they can transmit or receive information on material, financial and information flows within the SCDF.

### **3 Ensuring the Security of IoT Objects as Part of the SCDF Using Blockchain Technologies**

In recent years, the Blockchain technology is at the zenith of the Gartner Hype Cycle, and now there are a large number of projects in which this technology is used to organize trusted calculations, identify and authenticate objects [14]. Using Blockchain technology to store data that has been protected with cryptographic keys gives confidence that data will not be forged with [15, 16]. By nature, Blockchain is a distributed database in which storage devices are not connected to a common server. This database stores an ever-growing list of ordered records, so-called blocks. Each block contains a timestamp and links to the previous block. Blockchain makes intervention almost impossible, because it requires simultaneous access to database copies at all information processing centers in the SCDF. IoT data, Blockchain distributed architecture and the ability to verify ownership form the methodological basis for ensuring the appropriate level of confidentiality of business processes that occur during the functioning of SCDFs [16].

A distributed account, or the registry, which is used in Blockchain technologies, enables the ownership, transparency and general decentralization of the functioning of digital devices in the form of IoTs that are part of the SCDF.

The decentralized registries underlying Blockchain technologies are based on a circuit where the centers of trust and control are transferred to the virtual control network of the SCDF, whose nodes constantly record transactions in a specific order, into publicly available blocks, thereby creating a chain (Blockchain). Each block is a container with data that can be accessed only by the owner of the container, but any node of the SCDF can conduct the owner authentication procedure.

To build a SCDF, it is advisable to apply the so-called smart contracts: small programs that are recorded along with the data block. These programs contain rules by which data will be used. The main idea of reasonable contracts is that the parties can independently verify operations, agreeing on the conditions. Thus, metadata, including information about the owner of the object, can be recorded inside blocks, and Blockchain, among other things, is responsible for the resolution system [17].

The concept of using Blockchain to ensure the security of SCDF operation is based on three software platforms - TeleHash, BitTorrent and Ethereum. TeleHash is a decentralized and secure peering (P2P) protocol for exchanging data and transmitting messages over the network [18]. Under this security concept, data and messages transmitted using the TeleHash protocol are verified and certified by a third party; herewith the communication model is temporary, the client-server model is not used. BitTorrent is a peering (P2P) network protocol for cooperative file sharing, it implements the concept of file sharing through the interaction of source clients (seeders and leeches) [19]. The third component is Ethereum - based on the Blockchain virtual machine and a set of Web 3.0 services, which gives users the opportunity to work with the software environment of reasonable contracts, developing and filling it with content at their discretion, by supporting contract programming [20].

Based on the described software platforms, an environment of protected digital objects in the form of IoT is created, ensuring the stable functioning of the SCDF. At the same time, IoT objects within the SCDF can exchange data with each other through a hypermedia environment and form a single global continuous chain of transaction records, similar to Blockchain for bitcoins. The principal difference of this concept from the bitcoin technology is that the content and types of network entries will be determined by the contracts that will be concluded between the SCDF nodes.

A rational circuit for using Blockchain to increase the level of security for SCDF functioning will be its incorporation into the existing IoT object identification circuit as an alternative system for resolving objects or using it as an additional center of trust. For example, with a resolution in the system, the returned metadata may contain a link to the corresponding block in the decentralized registry.

New standards for IPv6-based protocols, such as 6LoWPAN, show that it is possible to create an efficient circuit for assigning unique identifiers for IoT objects in the SCDF.

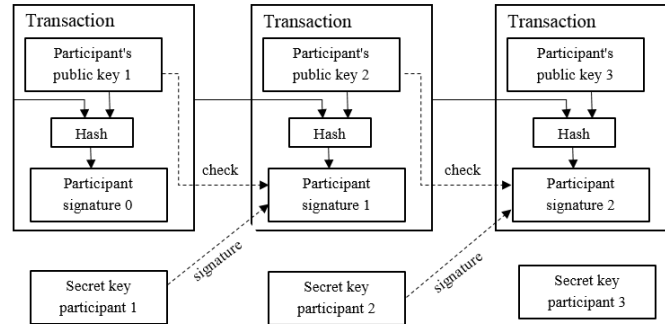
#### **4 The Identification Algorithm for Iot-Objects in the SCDF Based on the BLE/Blockchain Stack**

Encryption of blocks ensures that only those parts of the chain of blocks are accessible to users for which they have private keys, without which reading or changing the record is impossible. Encryption ensures synchronization of copies of a distributed chain of blocks for all users.

The decentralized peer-to-peer Blockchain network prevents individual participants from controlling the core infrastructure of the SCDF or destabilizing its operation. All SCDF participants are considered equal and are connected to the network using the same protocols. The circuit of using the described technology for identifying the user's rights to manage the IoT-object of the SCDF shows Fig. 1.

The participant's public key (1, 2, 3) is the address itself, for managing the IoT object.

The transaction hash is a unique identifier (checksum of the entire transaction from start to finish).



**Fig. 1.** The transaction process to identify the user rights of the IoT object as part of the SCDF

The signature of the participant (1, 2, 3) - with the help of the secret key confirms his authority as the owner of the object.

The generated transaction enters the block, and, like all new transactions, is launched into the network, where within a certain time, it will be attached to the chain. The network, in turn, contains a large number of nodes that form the new unit and verify the reliability of the transaction.

Nodes, by computation, select a hash for the block through a direct search of various values. When a value is found and it meets all requirements, the block is considered formed.

The application of the described algorithm ensures that all data in the SCDF is protected. Through the information in any block you can see the entire number of objects, but it is not possible to find out who owns them. In order to view the data, you need to confirm ownership of this transaction.

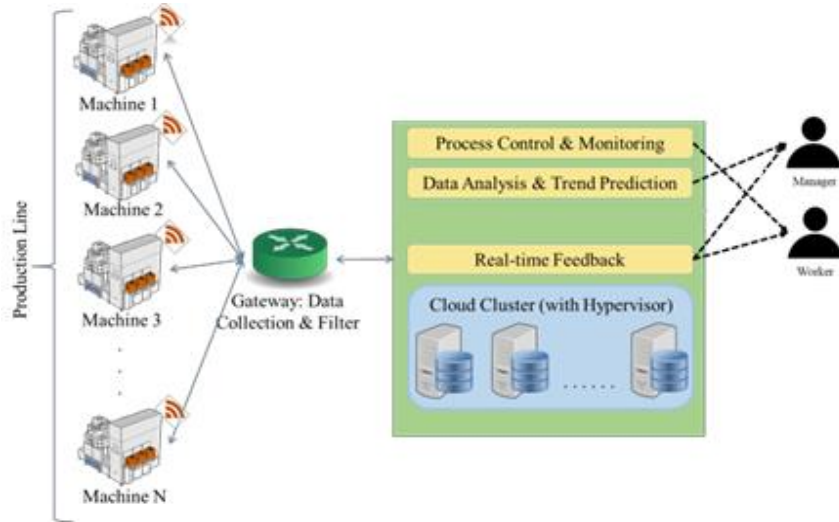
A special key is used to identify the user. In this case, the user has only one key, which has two different properties: having the key in hand, it will not be possible to find out the primary (source) information; it is impossible to select another data packet that would give the opportunity to create the same key.

IoT objects in the SCDF must be equipped with passive radio frequency identifications (RFID) and bluetooth low engineering (BLE) modules to ensure object identification and data transfer capabilities. BLE consists of two main parts: the controller and the host. The controller includes a physical and data link layer. The functions of the SCDF node include: the level of logical link control (LLC), the adaptation protocol (L2CAP), the attribute protocol (ATT), the generic attribute profile protocol (GATT), the security manager protocol (SMP); generic access profile (GAP). Additional application layer functionality can be implemented above the host level.

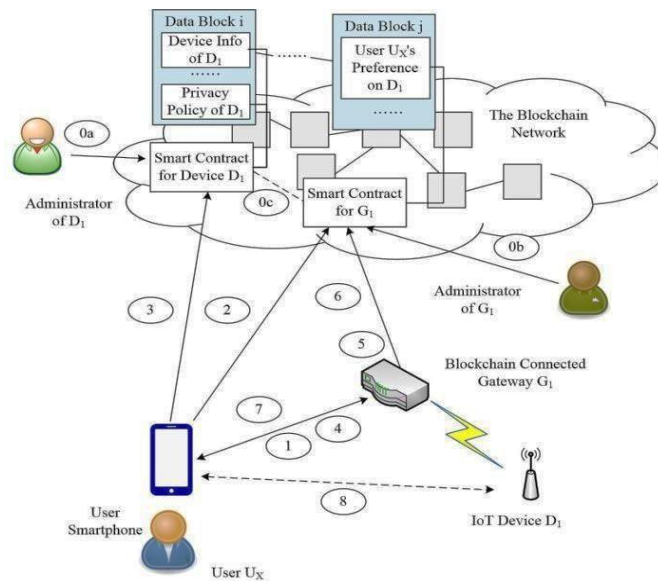
Using distributed registers to manage IoT objects is considered as the basic component of the SCDF architecture to ensure confidentiality, that is, in the proposed architecture, the Bluetooth-enabled gateway uses Blockchain technology to protect the user from unauthorized access (Fig.2).

Consider the algorithm of functioning of the gateway. This algorithm is illustrated in Fig. 3. We divide network participants into three main types: owners or administrators of IoT objects; gateway administrators; end users.





**Fig. 2.** Interaction of IoT objects during functioning of SCDF



**Fig. 3.** Schematic representation of the algorithm for identifying IoT objects in the SCDF using Blockchain technology

Before the user can access the IoT device, the device administrator saves device information and device privacy policy in the Blockchain network. In general, the device information includes a list consisting of: a unique device name; processing relevant information; device features, such as device type, device model name and number,

serial number, etc.; other attributes for management purposes, such as a list of device images, a privacy policy, and services provided.

Using the Ethereum platform, the IoT device administrator creates a smart contract for the device and uses the contract to manage the information and privacy policy of the device (step 0a).

The gateway administrator creates a smart contract for the gateway (Step 0b). After physically connecting the gateway to the IoT device, the gateway administrator will associate the smart device contract with the smart gateway contract (step 0c). When a user uses his smartphone to connect to the gateway (Step 1), he gets the address of the smart gateway contract. Information on devices connected to the gateway becomes available to the user (Step 2). Further, the user receives the address of the smart contract of the IoT device, and controls the confidentiality through the smart contract of the device (step 3).

After receiving guarantees of confidentiality of the IoT object, the user connects to the appropriate gateway and informs the gateway that it accepts or rejects its policy (Step 4). After accepting the conditions, the parameters are saved in the gateway (Step 5), the gateway also synchronizes the storage of data in the network (Step 6). When a user accesses an IoT device through a gateway (Step 7 and Step 8), the gateway will process user requests based on the saved user settings.

## 5 Conclusions

1. The possibilities of using IoT objects as part of the SCDF are considered, which will ensure a reduction in overhead costs for supporting the functioning of such a chain.
2. It is shown that one of the main problems of applying IoT objects in the SCDF is to ensure their level of protection from unauthorized access.
3. It is proposed to use Blockchain technology in the form of a set of software platforms (TeleHash, BitTorrent and Ethereum) for enhancing the identification and authentication of IoT objects as part of the SCDF.
4. The central result of the research is the developed algorithm for identifying IoT objects within the SCDF and their authentication procedures, followed by authorization of the user to provide him with access rights to resources. The scientific novelty of the result lies in the complex using radio frequency identification technologies, BLE and Blockchain, as the basic processing and maintenance architecture for data to resolve conflicts in the field of confidentiality, that may occur during the operation of the SCDF.
5. In the future, the intellectualization of objects of the Internet of things is supposed by presenting them in the form of intelligent agents as part of the SCDF.

## References

1. Bauersoks, D., Kloss, D.: Logistika: integrirovannaya tsep' postavok [Logistics: integrated supply chain]. 2nd edn. Olymp-Business, Moscow, 2008.

2. Rahimi, Y., Shostak, I., Feoktystova, O.: Nechetkoe modelyrovanye transportnoy sostavlyayushchey polnoy lohystycheskoy tsepy postavok sukhofruktov v Ukrainu [Fuzzy modeling of the transport component of the complete logistics chain of dried fruit deliveries to Ukraine]. *Control systems, navigation and communication* 3(49), 83-87 (2018).
3. Shostak, I., Rahimi, Y.: Modelirovaniye polnoy logisticheskoy tsepi postavok sukhofruktov v Ukrainu s primeneniyyem vlozhennykh setey Petri [Modeling of the complete logistics supply chain of dry fruits to Ukraine using embedded Petri nets]. *Modern Information Systems* 2(4), 45-48 (2018).
4. Algazinov, E. K.: Analiz i komp'yuternoye modelirovaniye informatsionnykh protsessov i system [Analysis and Computer Modeling of Information Processes and Systems]. Dialog-MIFI, Moscow, 2009.
5. Kharchenko, V., Illiashenko, O., Boyarchuk, A., Sklyar, V., Phillips, C.: Emerging curriculum for industry and human applications in Internet of Things. In: 9th IEEE International Conference on Intelligent Data Acquisition and Advanced Computing Systems: Technology and Applications (IDAACS), pp. 918-922. IEEE, Bucharest (2017).
6. Arshad, R., Zahoor, S., Shah, M. A., Wahid, A., Yu, H.: Green IoT: An Investigation on Energy Saving Practices for 2020 and Beyond. *IEEE Access* 5, 15667-15681 (2017).
7. Lord, N. Supply chain cybersecurity: experts on how to mitigate third party risk, <https://digitalguardian.com/blog/supply-chain-cybersecurity>, last accessed 2018/03/21.
8. Ukraintsev, V.B., Akhokhov, A.M.: Tekhnologiya blokcheyn v logistike: tsifrovizatsiya i pe-rspektiviy ispol'zovaniya [Blockchain technology in logistics: digitalization and use prospects]. *Logistics and supply chain management* 6, 42-48 (2017).
9. Gulyagina, O.S.: Blokcheyn v logistike i upravlenii tsepyami postavok: opyt i perspektivy primeneniya [Blockchain in Logistics and Supply Chain Management: Experience and Perspectives of Application]. In: 5 International Correspondence Scientific and Practical Conference on Logistics Systems and Processes in the Conditions of Economic Instability, pp. 48-52. BGATU, Minsk, 2017.
10. The Identity of Things (IDoT): Access Management (IAM) Reference Architecture for the Internet Of Things (IoT), <https://pdfs.semanticscholar.org/08c3/4cfe944aee53d004904607f0109326a42990.pdf>, last accessed 2018/06/09
11. Chaudhuri, Abhik.: Identity and Access Management for the Internet of Things, <https://downloads.cloudsecurityalliance.org/assets/research/internet-of-things/identity-and-access-management-for-the-iot.pdf>, last accessed 2018/06/11
12. Ndibanje, B. Lee, H.-J., Lee, S.-G.: Security Analysis and Improvements of Authentication and Access Control in the Internet of Things. *Sensors* 14, 14786-14805 (2014).
13. Chatterje, S.: A Survey of Internet of Things (IoT) over Information Centric Network (ICN). P.1-18, [https://www.researchgate.net/publication/326987774\\_A\\_Survey\\_of\\_Internet\\_of\\_Things\\_IoT\\_over\\_Information\\_Centric\\_Network\\_ICN](https://www.researchgate.net/publication/326987774_A_Survey_of_Internet_of_Things_IoT_over_Information_Centric_Network_ICN), last accessed 2018/08/19
14. Blockchain in logistics: perspectives on the upcoming impact of blockchain technology and use cases for the logistics industry, <https://www.logistics.dhl/content/dam/dhl/global/core/documents/pdf/glo-core-blockchain-trend-report.pdf>, last accessed 2018/09/12
15. Zheng, Z., Xie, S., Dai, H.-N., Chen, X., Wang, H.: An Overview of Blockchain Technology: Architecture, Consensus, and Future Trends. In 6th IEEE International Congress on Big Data, pp. 557 -564. IEEE, 2017.
16. Blockchain Technologies for the Internet of Things: Research Issues and Challenges, <https://arxiv.org/pdf/1806.09099.pdf>, last accessed 2018/10/19

17. Medrish, M. A., Belyavskiy, D.M., Darbinyan, S.S., Zasurskiy, I.I., Kazar'yan, K. R., Levova, I.Yu., Kharitonov, V.V.: Tsifrovaya identifikatsiya ob"yektov [Digital identification of objects]. Nauchnoye obozreniye, Moscow, 2016.
18. Telehash Secure Mesh Protocol, <http://telehash.org/v3/spec/v3.0.0-stable.pdf>, last accessed 2018/06/10
19. Protocols, Cooperation and Competition, [http://medianetlab.ee.ucla.edu/papers/chapter\\_P2P\\_hpark.pdf](http://medianetlab.ee.ucla.edu/papers/chapter_P2P_hpark.pdf), last accessed 2018/07/23
20. Vujicic, D., Jagodic, D., Sinisa, R.: Blockchain technology, bitcoin, and Ethereum: A brief overview. In: 17th International Symposium on INFOTEH-JAHORINA, pp. 1-6. IEEE, Bosnia and Herzegovina, 2018.

# Application of the Booking.com Analytics Software Tools in Reliable Processing of Big Data in Hotels Management

Vladimir Sklyar, Vyacheslav Kharchenko

National Aerospace University “KhAI”, Kharkiv, Ukraine  
v.sklyar@csn.khai.edu, v.kharchenko@csn.khai.edu

**Abstract.** The paper contains results obtained in area of big data analysis for hotel revenue management. Authors challenge the area of hotel management since they have and still improve skills in this area. The paper presents the new results obtained for previously developed Advanced Hotel Management Framework. We use comparatively the new tool “Booking.com Analytics” developed by the company Booking.com B.V. in 2016 for hotels involved in a global partnership program. We learned available features and data from the “Booking.com Analytics”. The performed case study is associated with a mini-hotel situated in Cambodia. We studied data related with booking percentage depending from tourists’ countries of origin, book window percentage, cancellation of reservation percentage, guests’ review rating, as well as special genius guests’ program percentage. After that we tried to find statistical dependencies between a managed value of room daily rate and available big data. In conclusion, the obtained results are discussed.

**Keywords:** Hotel Management, Big Data, Revenue Management.

## 1 Introduction

Tourism including hotel industry consists 10% of the world economy in a sense of GDP (Gross Domestic Product) as it is stated in United Nations World Tourism Organization (UNWTO) Report 2018 [1,2]. Big data collected at booking systems sites could help to organize a competitive strategy for cost-effective hotel management system and hospitality industry development [3,4]. However, opportunities provided by big data request careful using since any prognosis models have to be completely tested before its implementation for business decision-making [5]. So we need to define reliability of big data in sense of its supporting of hotel business sustainability [6].

The tasks related with revenue management systems have been specified and partly solved before the “big data” term became a hot topic. For example, a framework for revenue hotel management has been developed in [7]. The paper [7] was published in 2009 and predicted the main components of the modern tools for big data analysis, including forecasting module which scans and analyzes of historical booking and occupancy patterns and current reservations and fits a quantitative forecasting, and optimization module for predictions and decisions allocation.

A detailed literature review in area of hotel revenue management (RM) is provided in [8]. The elements of the hotel system discussed in the paper include hotel RM centers, data and information, the pricing and non-pricing RM tools, the RM software, and the RM team. The stages of RM process have been identified as goal setting, collection of data and information, data analysis, forecasting, decision making, implementation and monitoring. Special attention was paid to ethical considerations in RM practice, the connections between RM and customer relationship management, and the legal aspect of RM. The paper [8] provides a review of forecast mathematical models based on big data that produce recommendations for the optimal levels of prices, rate structures, overbookings and help the revenue manager take proper decisions [9]. These mathematical models include the following: deterministic linear programming, integer programming, dynamic programming, Markov model, bid-price methods, price setting method, expected marginal revenue technique, stochastic programming, probabilistic rule-based framework, Monte Carlo simulation, fuzzy goal programming, and robust optimization [10].

There are some important and successful researches in area of big data using for hotel management. In [11] authors discuss how to convert data into knowledge by investigation the perceptions that managers have of the value and reliability of using big data to manage of hotel revenue on the base of pricing decisions [12]. The paper [11] represents some general findings which entail the following barriers in big data application: data overload, tensions between automated and manual decision making, fast and frequent decision making, managers behavior based on belief in local insights and instincts. It provides a clear message concerning a need for automated revenue systems to be flexible enough for managers to import the local data, information, and knowledge that they believe leads to revenue growth [13]. Whilst the academic literature has shown to place its faith in the increasing automation of revenue management decision-making using big data and analytics which should require no user input, the research [11] has placed this under a question.

The paper [14] states that the advent of the era of large data is the development of the hotel industry transformation opportunities, but also for the construction of the wisdom of the hotel made a series of new problems, the use of large data will fundamentally change the current status of hotel management, the birth of a new model of hotel management.

An alternative approach for operational hotel management which is based on dependability has been proposed in paper [15]. Advanced Hotel Management Framework (AHMF) [15] contains three the following main parts: strategic planning, operation and maintenance, as well as infrastructure management and assets management. More issues related with safety and security assurance in critical areas, including hospitality industry, can be found in [16,17].

Based on the above analysis we can observe the present gap between academic investigations targeted to design some ideal hotel big data analysis tools and already existing industrial products [18,19]. The most impressive results in area of big data analytics for hotel management are obtained by the company Booking.com B.V.

In this paper we discuss features of the “Booking.com Analytics” tools provided by the company Booking.com B.V. The main feature of the “Booking.com Analytics” is representation of collected statistic to support decision making in hotel management. To use big data from the “Booking.com Analytics” we hypothesize and check some

dependencies between management decisions and rooms revenue amount. We are going to understand opportunities which are provided by modern big data analysis tools in area of hotel revenue management. The paper objective is to get decision making strategy for hotel management with support of the “Booking.com Analytics” tools. To achieve this paper objective, the following sections are included.

Firstly, in Section 2, we learn features of global reservation services focusing on Booking.com. Features of the “Booking.com Analytics” are analyzed in details.

Secondly, in Section 3, we make case study of a mini-hotel operation in Cambodia. We analyze big data available from the “Booking.com Analytics” and extract statistics which can be directly appropriate for managerial decision making.

After that, in Section 4, we hypothesize some dependencies related with decision making (stated room daily rate) and hotel revenue. Another checked hypothesis is about dependency between hotel revenue and number of tourists looking for a hotel in your area.

Conclusions made at the final part of the paper are directed to support of hotel managerial decision making and demonstrate some constrains in big data using for reliable and sustainable decisions making.

## 2 Analysis of Opportunities Provided by Global Booking Platform

### 2.1 Hotel Analytics Tools

Booking.com is the global leader in connecting travellers which contains more than one million of properties in one database. “Booking.com Analytics” has been released in 2016 [20]. This software tool is based on Big Data collected by Booking.com during many years of operation. “Booking.com Analytics” empowers property owners to grow their businesses with bespoke, actionable data and advice that is delivered in real time, powered by a customizable dashboard. This product is available globally as just one of the standard perks of partnership with Booking.com (as named Booking.com extranet).

Other global booking services (for example, AirB&B [21]) provide not so mature platform for Big Data analysis, so in this paper we will consider only “Booking.com Analytics”. “Booking.com Analytics” menu contains the following parts:

- **Home** includes only the main performance information;
- **Rates & Availability** supports the calendar with room daily rates broken down into specific dates and types; rooms occupancy and availability also are taken into account;
- **Promotions** allow to creating discount actions in addition to **Rates & Availability**;
- **Reservations** contain details of booking made by the past and future guests;
- **Property** supports description of hotel in respect with user interface reflected when guests come to your hotel page at the Booking.com system;

- **Opportunities** should encourage hotels managers to provide some discounts to guests, for example, in the framework of Genius frequent guests program;
- **Inbox** supports correspondence with guests as well as management of Booking.com;
- **Guest Reviews** aggregates scores of written guests feedbacks and ratings;
- **Finance** contains the base for calculation of commission which a hotel has to pay monthly to Booking.com;
- **Analytics** supports the “Booking.com Analytics” tools which is discussed in details below;
- **Marketplace** provides opportunities to integrate additional analytic tools, some tools are free, but some tools are not free.

## 2.2 Features of “Booking.com Analytics”

The “Booking.com Analytics” currently features the following parts of menu:

- The **Analytics Dashboard** aggregates the main performance overview including number of booked room nights, room revenue (the total amount paid by guests), and average daily rate what is room revenue divided to room nights; also the Analytics Dashboard contains links to the main reports briefly discussed below;
- The forward-looking **Pace Report** enables partners to benchmark their sales on Booking.com versus the previous year and compare their performance with aggregated data from their competitors;
- The **Sales Statistics** report provides an easy-to-digest snapshot of a property’s sales performance over the past year;
- The **Booker Insights** provides in-depth insights into country of origin, device used to book, and travel purpose;
- The **Bookwindow Information** is focusing on how far in advance Booking.com customers are booking their accommodation;
- The **Cancellation Characteristics** gives details about percentage of canceled guests bookings;
- The **Guest Review Score** provides data concerning property’s reviews rates written by guests;
- The **Manage Competitive Set** option allows to choosing up to ten hotel in your region to compare your Key Performance Indicators (KPIs) with the KPIs of the closest competitors;
- The **Genius Report** demonstrates percentage of booking made in accordance with Booking.com Genius program of frequent travellers;
- The **Ranking Dashboard** shows how you perform when guests search for properties in your area.

For an even deeper dive into the data, partners can compare their data with the following:

- Last year (own data);
- Peer group including all properties of the same type and star rating (if applicable) in a partner’s destination;



- Competitive set including ten properties of the partner’s choosing;
- Market including all properties in the partner’s destination, regardless of type or star-rating.

Partners can further slice and dice the data for deeper insights on:

- Ranking with their different custom and pre-defined groups of competitors;
- Delta changes over time;
- Date ranges (7, 14, 30, 60, 90, or 365 days).

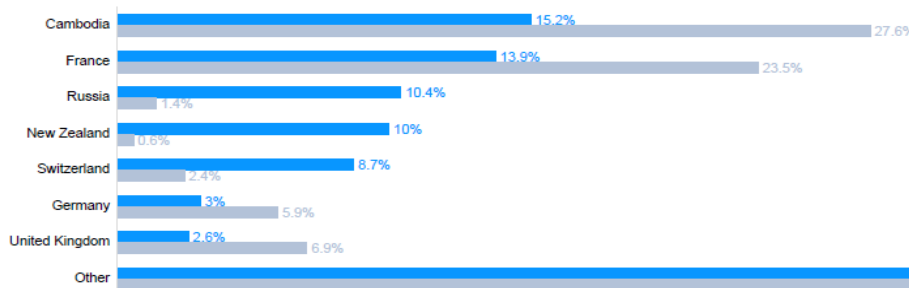
The next Section provides examples related with analytics reports generation.

### 3 Case Study: Details of Big Data Provided by “Booking.com Analytics”

In this Section we consider case study based on the real experience of a mini-hotel “Chateau Puss in Boots” operated in Kep city, Cambodia [22]. The considered hotel started to operate in December 2018, so in March 2019 we have available data only for four months. We do not represent financial data in this paper. It is necessary to introduce several important assumptions to understand the limitations of the study:

- We consider a private mini-hotel with capacity up to 15 room operating activities s (30-40 people), in which there are no corporate procedures, and everything is simplified to the limit in order to reduce overhead costs; therefore, all operating activities are concentrated on the hands of the owners without the participation of any structural units;
- We do not consider the structure of the room daily rate and additional revenue points (bar and restaurant, rent of bicycles and motorbikes, sale of tickets and excursions, spa etc.);
- We do not consider a general approach to hotel management; however, this is an important framework, which is discussed, for example, in [15].

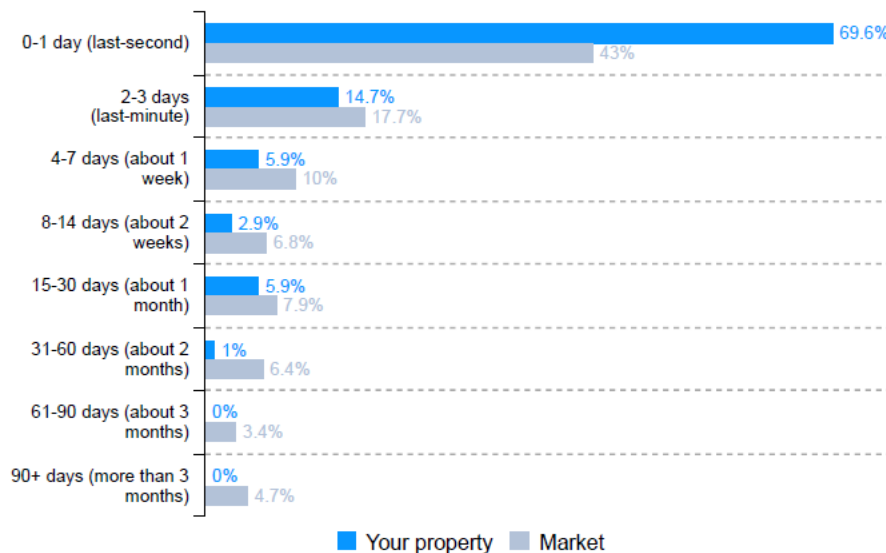
Fig. 1 provides a part of the Booker Insights concerning distribution of bookings between tourists’ countries of origin. The studied hotel is operated by owner with Ukrainian citizenship what is important from the point of view of nationals’ distribution.



**Fig. 1.** Case Study: Booking percentage depending from tourists' countries of origin (the studied hotel against the market)

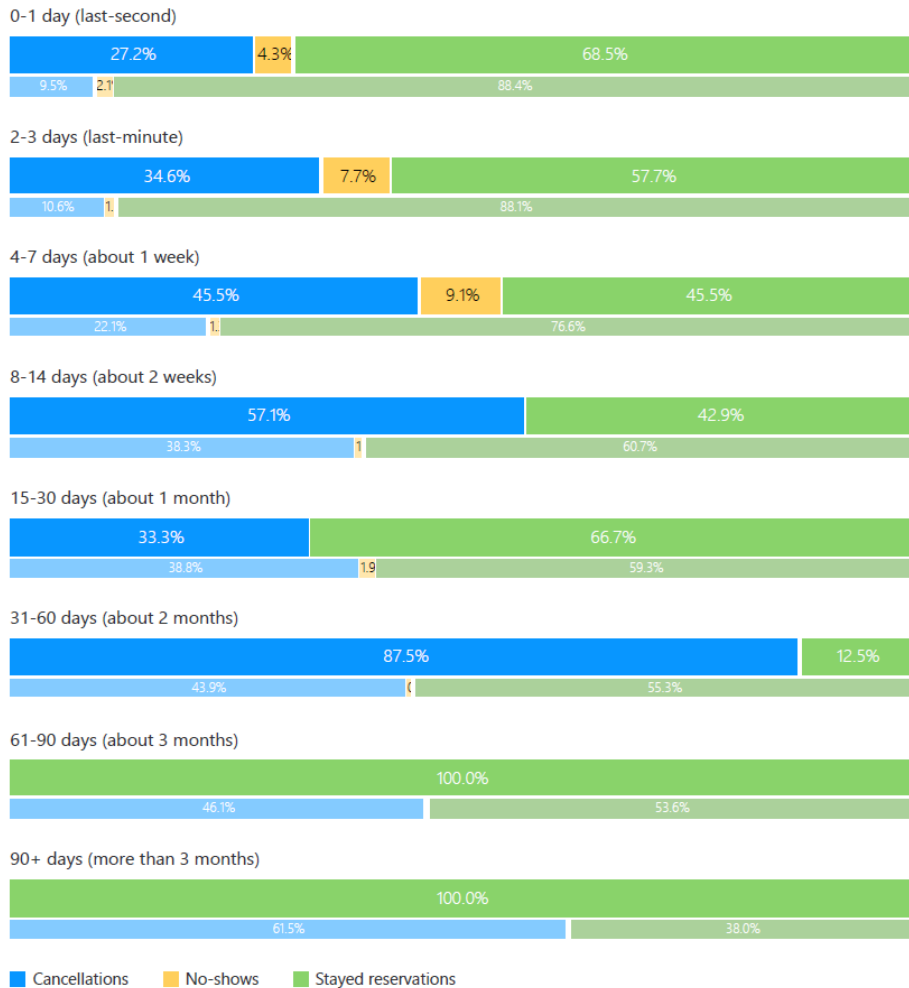
Fig. 1 demonstrates countries distribution different from the market. Tourists from Cambodia and France represent about 50% of tourist market in Kep, however, in the considered case study they take only 15% and 13% respectively. It can be explained by conservatism of local Cambodian tourists who like to stay at the hotel operated by local Cambodian owners. The same explains the lower percentage of French tourists many of whom are sensitive from the point of view of French language. Russian tourists also like when hotel staff can speak in Russian and it explains why they submit more than 10% of bookings against 1.4% at the market. Concerning New Zealand (10% of booking against 0.6% at the market) and Swiss (8.7% against 2.4% at the market) tourists the higher percentage can be explained by good value for money since tourists from these countries are conservative from the point of view of unnecessary spending of money. The detailed Booker Insights report provides also information separated by countries concerning average daily rate, average length of stay, and cancelation rate. These data are important for prognosis of behavior of tourists depending from a country of origin.

Fig. 2 represents the Bookwindow Information related with percentage of reservations depending from a book window (how many days in advance a room has been booked). A large book window provides more opportunities from a point of view of a room daily rate specification. Also, room daily rate shall take into account local and global festivals and days off. General analytics say that only few guests make reservation for more than 30 days in advance. A diagram on Fig. 2 shows that about 70% of all bookings have been made just before guests check-in. It is not perfect since risk of empty rooms is increased, but from the other hand it pushes to more precise setting of room daily rate for the actual date. Also, the Bookwindow Information report represents a diagram with average daily rate per a book window.



**Fig. 2.** Case Study: Book window percentage

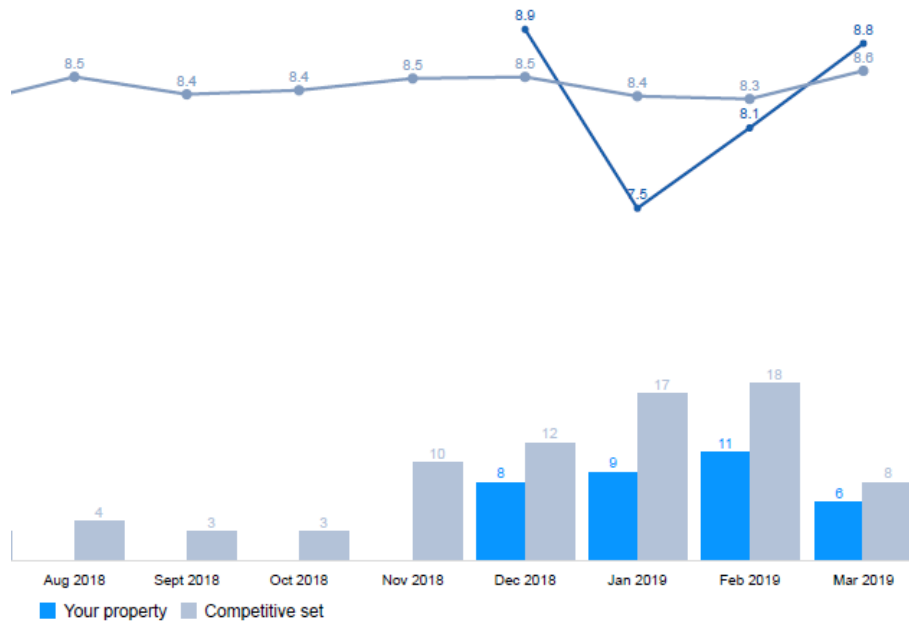
An important metric which affects any hotel business is cancellation percentage (see Fig. 3). The last-minute cancellation is usually stressful since it essentially decreases a book window and it increases a risk that a canceled room will not be sold out. Unfortunately for the analyzed case study we have 34% of cancellation rate while cancellation rate for the considered market is 28%. The most part of cancellations is explained by reservation with a book window more than one month. It is difficult to elaborate an effective strategy of cancellations number decreasing. People often change plans, or they can find that some another hotel proposal is more attractive. We try to communicate with guest as soon as we get a reservation but this strategy is also not completely successful.



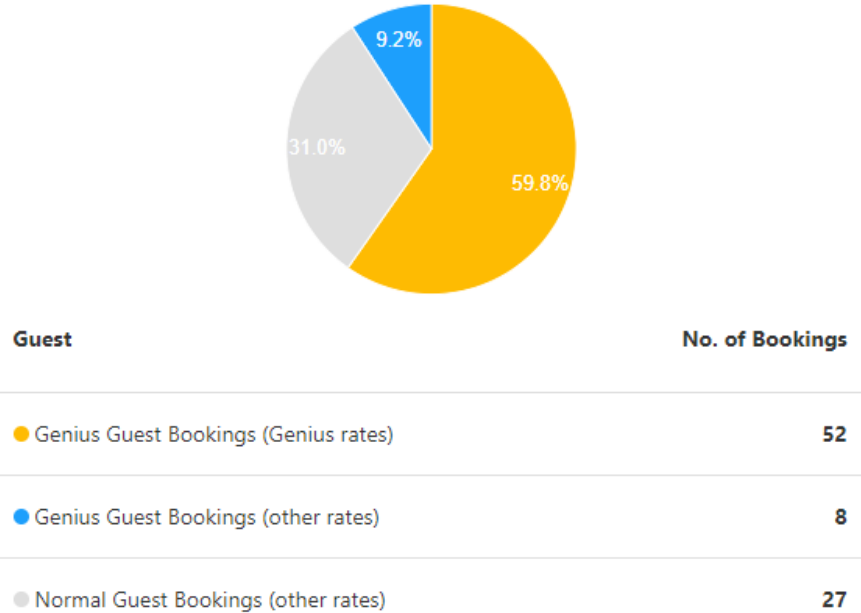
**Fig. 3.** Case Study: Cancellation of reservations percentage

A hotel business highly depends from a reputation what is supported at the Booking.com with guest reviews. Guest review is based on rating (from 2.5 to 10) of the following hotel features: cleanliness, comfort, location, facilities, staff, and value for money. The Guest Review Score report contains integrated values of hotel rating (see Fig. 4).

Booking.com supports loyalty program for frequent travelers with the name Genius. Registered Genius users of Booking.com get discounts for reservations from 10% and more. To get Genius travellers the hotel has to support this program (see Fig. 5).



**Fig. 4.** Case Study: Guests' review rating



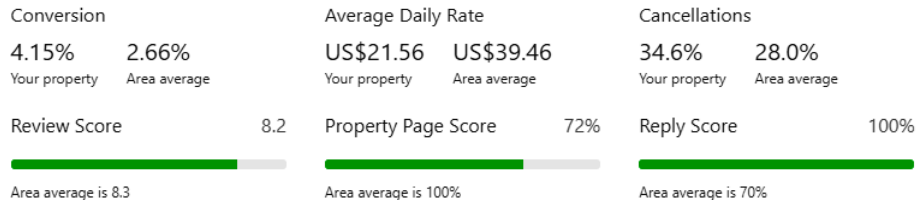
**Fig. 5.** Case Study: Genius guests percentage

But an issue is the hotel has to provide discounts for its own expenses. It means that the price for Genius guest is only 90% (sometimes even 85%) from the stated at the Booking.com daily room rate. From the one hand it entails a general hotel revenue decreasing. But from the other hand many Booking.com users are involved in Genius program and these users appreciate when a hotel supports this program. So involvement of a hotel in Genius program can increase the total hotel revenue despite the fact that daily room rate decreases. What is important to remember, daily room rate shall take into account a risk of 10% or 15% decreasing for Genius guests. For the considered case study (Fig. 5) Genius guests consist about 70% of all guests what is a great amount for reservations.

The Ranking Dashboard (Fig. 6) presents the following factors influencing to the hotel revenue score in comparison between your hotel and average rate at the market:

- Conversion is the percentage of the hotel page views that converted into reservations;
- Average Daily Rate combined revenue earned from sold rooms divided by the number of sold rooms;
- Cancellations shows the percentage of all reservations that were canceled (Fig. 3);
- Review Score is calculated using the ratings left by guests (Fig. 4);
- Property Page Score shows how complete the hotel page is in regards to information and pictures;
- Reply Score takes into account the hotel answering guests as soon as possible.

### Factors influencing your score



**Fig. 6.** Case Study: Ranking for revenue influencing factors

Taking into account the above six factor can affect the hotel revenue amount, it makes a sense to consider the associated dependency. However, cancelation percentage, review score, property page score, and reply score can affect only indirectly to revenue. So it looks impossible to find dependencies between revenue score and indirect factors. What seems prospective for big data analysis are conversion percentage and average daily rate. In the next Section we consider hypothesis related with dependency of the hotel revenue score from conversion rate and daily rate.

## 4 Case Study: Checking of Big Data Based Hypothesis

So we can get big data from the “Booking.com Analytics”, and it we would like to understand how Big Date using can help in the statement of the daily room rate. Economic science suggests that there are supply and demand curves, and consequently, there is a certain optimal price that allows you to extract the maximum revenue from the sale of a product or a service. Type I errors (a price increase above the optimum) lead to the refuse of customers to purchase, while type II errors (a price reduction below the optimum) lead to a decrease in a potential revenue amount.

Thus, we state the *Hypothesis 1 (H1)*: There is a relationship between the rooms’ revenue  $S$  and daily room rate  $C$ .

Formally, for each calendar day for one of the room, this can be described by the following minimax criterion:

$S = \max(c) \wedge f = 1$ , where  $S$  is room revenue numerically equal to daily room rate  $c = \{c_{\min}..c_{\max}\}$  (room daily rate belongs to a certain range);  $f = \{0;1\}$  is a binary sale indicator:  $f = 0$  if the room is not sold and  $f = 1$  if the number is sold.

If there are several rooms of the same type, then not all rooms can be booked every day, in addition, the daily rate  $c_i$  for the same rooms may change during the book window, and the minimax criterion looks like:

$S = \max(\sum c_i) \wedge F = (\sum f_i) \rightarrow N$ , where  $c_i$  is daily room rate (the rate for the same room category can change),  $f_i = \{0;1\}$  is a binary sale indicator,  $F = \{0..N\}$  is the number of rooms sold in one category, the total number of which is  $N$ .

If the hotel has several categories of rooms, then each of them applies the above criterion, and the total rooms’ revenue is formed as the sum of sales of all categories of rooms, or everything can be reduced to a general formula, if you increase the dimension by adding another index. In our study we will focus on double rooms’ cate-

gory, as the most representative. The considered mini-hotel has five double rooms, so  $N = 5$ ,  $F = \{1..5\}$ .

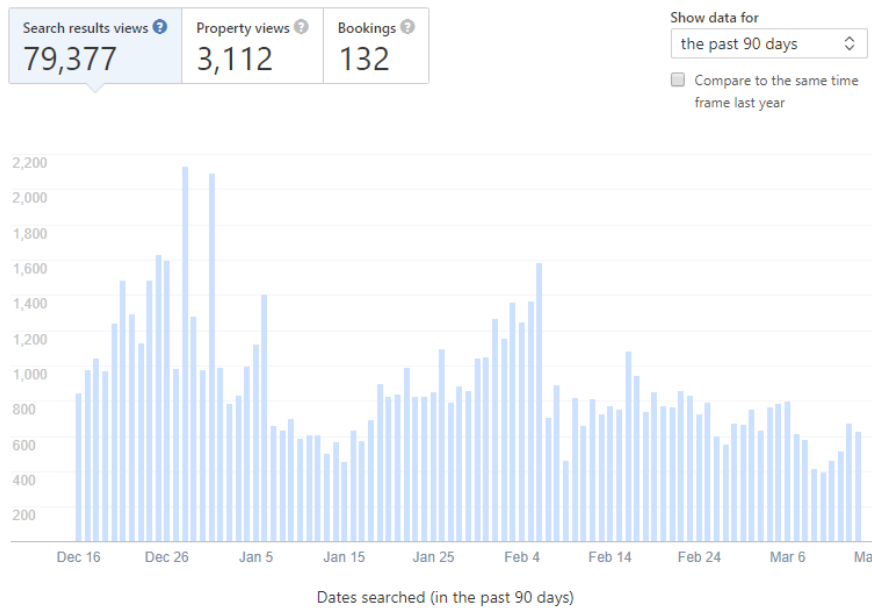
Now let's analyze the mutual dependence between rooms' revenue and room daily rate ( $H1$ ). Linear regression does not make a sense because the higher room daily rate obviously produces the higher revenue. Therefore, we calculate a regression coefficient as a measure of relation between two arrays of values of two random variables (relation of covariance value to product of standard deviations):

$$r(S, C) = \text{Cov}(S, C) / [\sigma(S) \cdot \sigma(C)] =$$

$$= (s_i - s_{Avg}) \cdot (c_i - c_{Avg}) / \sqrt{(s_i - s_{Avg})^2 \cdot (c_i - c_{Avg})^2}.$$

Values of daily room rate  $c_i$  and daily room revenue  $s_i$  are defined for every day during four months (120 pairs of values). Performed calculation gives us  $r(S, C) = 0.354$ . It means that there is not a statistical co-relation between revenue amount  $S$  and room daily rate  $C$ . However, our perception is still there should be a relationship.

One more perception is than more guests are looking for a room in your than more guest will you get in your hotel. The "Booking.com Analytics" supplies us with such data (Fig. 7). Fig. 7 represents numbers of daily search results for Kep (Cambodia). The conversion ratio is  $132 / 79\,377 = 0.16\%$  that means only 16 people booked the hotel from every 10 000 people looking for accommodation.



**Fig. 7.** Case Study: Daily search results

Let's state the *Hypothesis 2 (H2)*: There is a relationship between the rooms' revenue  $S$  and daily search results  $R$ .

Values of daily search results  $r_i$  and daily room revenue  $s_i$  are defined for every day during four month (120 pairs of values). Performed calculation gives us  $r(S,R) = -0.172$ . It means that there is not a statistical co-relation between revenue amount  $S$  and daily search results  $R$ .

## 5 Conclusions

In this paper we analyzed features and data provided by “Booking.com Analytics” which is modern powerful tools for hotels big data analysis. There are the following important data which can be extracted by Booking.com partners from extranet:

- Daily search results;
- Number of property page views;
- Number of booking;
- Room daily rates and average room daily rate;
- Revenues and average revenue;
- Percentage of booking cancelations.

Aggregated are available for different date ranges (7, 14, 30, 60, 90, or 365 days). Data can be compared with your hotel results during the last year as well as with average market data of average data of the hotels from your nearest pre-defined competitors set.

In the paper we tried to get decision making strategy for hotel management with support of the “Booking.com Analytics” tools. In fact, the hotel manager has only one “control button” which is room daily rate on the specific date. We stated two hypotheses:

- *Hypothesis 1 (H1)*: There is a relationship between the rooms’ revenue  $S$  and daily room rate  $C$ ;
- *Hypothesis 2 (H2)*: There is a relationship between the rooms’ revenue  $S$  and daily search results  $R$ .

Despite our perception both hypotheses turned out not true, what is confirmed by low values of regression coefficients ( $r(S,C) = 0.354$  and  $r(S,R) = -0.172$ ).

However, Booking.com states, that data contained in the “Booking.com Analytics” is harnessed by a proprietary logic that converts it into a prioritized list of actionable business advice. Also, Booking.com thinks that partner hotels can quickly peruse the opportunities, select the most relevant options for their property, and instantly implement them to enhance their listing and grow their business through Booking.com. After making the suggested adjustments, partners can then return to the analytics dashboard to easily monitor the results of their efforts, track their progress over time, and identify new areas for potential growth. In practice there are not any models which support the above statements.

Our conclusion is that big data for hotel management can be used only as a starting point for basic analysis. Reliable and sustainable decision making strategy shall additionally take into account experience, perception and intuition together with macro and micro economic trends. Discussing the hotel decision making strategy, we should remember the manager has only one the real tool to affect the revenue amount. This



tool is the daily rate per room. Of course, there are many issues affecting the daily rate, but all the hotels activities are concentrated in this variable.

## References

1. Mandal, P., Vong, J.: *Development of Tourism and the Hospitality Industry in Southeast Asia*. Springer (2018).
2. Minazzi, R.: *Social Media Marketing in Tourism and Hospitality*. Springer (2015).
3. Abrate, G., Viglia, G.: Strategic and tactical price decisions in hotel revenue management. *J. Tourism Management* **55**, 123-132 (2016).
4. Bodea, T., Ferguson, M., Garrow, L.: Choice-Based Revenue Management: Data from a Major Hotel Chain. *J. Manufacturing and Service Operations Management* **11(2)**, 356-361 (2009).
5. Gautam, B., Asami, H., Batajoo, A., Fujisaki, T.: Regional Revival through IoT Enabled Smart Tourism Process Framework (STPF): A Proposal. In: 2016 Joint 8th International Conference on Soft Computing and Intelligent Systems (SCIS) and 17th International Symposium on Advanced Intelligent Systems (ISIS), pp. 743-748. Sapporo (2016).
6. Oskam, J., Dekker, D., Wiegerink, K.: *Innovation in Hospitality Education: Anticipating the Educational Needs of a Changing Profession*. Springer (2018).
7. El Gayer, N., Saleh, M., Atiya, A., El-Shishiny, H., Zakhary, A., Habib, H.: An integrated framework for advanced hotel revenue management. *Int. J. of Contemporary Management* **23(1)**, 84-98 (2011).
8. Ivanov, S., Zhechev, V.: Hotel revenue management – a critical literature review. *J. Tourism Review* **60(2)**, 175-197 (2012).
9. Cetin, G., Demirciftci, T., Bilgihan, A.: Meeting revenue management challenges: Knowledge, skills and abilities. *Int. J. of Hospitality Management* **57**, 132-142 (2016).
10. Padhi, S., Aggarwal, V.: Competitive revenue management for fixing quota and price of hotel commodities under uncertainty. *Int. J. of Hospitality Management* **30(3)**, 725-734 (2011).
11. Egan, D., Haynes, N.: Manager perceptions of big data reliability in hotel revenue management decision making. *Int. J. of Quality & Reliability Management* **36(1)**, 25-39 (2019).
12. Queenan, C., Ferguson, M., Stratman, J.: Revenue management performance drivers: An exploratory analysis within the hotel industry. *J. of Revenue and Pricing Management* **10(2)**, 172-188 (2011).
13. Lamest, M., Brady, M.: Data-focused managerial challenges within the hotel sector. *J. Tourism Review* **74(1)**, 104-115 (2019).
14. Xiao, L.: Analysis on Hotel Management Strategy in Big Data. In: *Proceedings of the 2017 International Conference on Innovations in Economic Management and Social Science (IEMSS 2017)*. Hangzhou (2017).
15. Sklyar, V., Kharchenko, V.: RAMS Issues in Hotel Management. In: *Proceedings of the 14th International Conference on ICT in Education, Research and Industrial Applications (ICTERI 2018)*, pp. 624-636. Kyiv (2018).
16. Sklyar, V., Kharchenko, V.: Assurance Case Driven Design based on the Harmonized Framework of Safety and Security Requirements. In: *Proceedings of the 13th International Conference on ICT in Education, Research and Industrial Applications (ICTERI 2017)*, pp. 670-685. Kyiv (2017).

17. Sklyar, V.: Application of Reliability Theory to Functional Safety of Computer Control Systems. *J. Reliability: Theory & Applications* **12(1)**, 26-37 (2017).
18. Pongsathornwiwat, N., Jeenanant 201ta, C., Huynh, V.: Managing knowledge management competency by integrating with collaborative behavior into improving hospitality innovation capability. In: *Proceedings of the 2016 IEEE International Conference on Management of Innovation and Technology (ICMIT)*, pp. 214-219. IEEE Press, Bangkok (2016).
19. Yan-Li, B., He-Feng, H.: Framework and management of competitive intelligence system for tourist hotels in the era of big data. In: *Proceedings of the 2016 2nd IEEE International Conference on Computer and Communications (ICCC)*, pp. 60-64. IEEE Press, Chengdu (2016).
20. Booking.com's Analytics and Opportunity Centre, <https://news.booking.com/bookingcoms-analytics-and-opportunity-centre/>, last accessed 2019/05/12.
21. Airbnb Performance Page, <https://www.airbnb.com/performance>, last accessed 2019/05/12.
22. Hotel Chateau Puss in Boots Homepage, <https://kepchateau.blogspot.com/>, last accessed 2019/05/12.

# Reliability of Adaptive Traffic Lights Ensured by Warm Standby With Estimation of its Use

Oleksandr Makarichev<sup>1</sup>[0000-0003-2442-1208], Peter Horbachov<sup>2</sup>[0000-0002-8180-4072],  
Oleksandr Voronkov<sup>3</sup>[0000-0003-2744-7948] and Stanislav Svichynskyi<sup>4</sup>[0000-0002-8549-1712]

<sup>1, 2, 3, 4</sup>Kharkiv National Automobile and Highway University, Kharkiv 61002, Ukraine  
gorbachov.pf@gmail.com

**Abstract.** For the case when quantitative characteristics of traffic flows and the failure rates of traffic lights' elements are known, quantitative relationships for the feasibility analysis of warm standby of the adaptive traffic lights at intersections have been found. The equations and recurrence relations of their probability distributions are obtained as the Laplace transform of sequences of times of limited permissive phases of alternative movement directions. The intelligent system of traffic control with the adaptive traffic lights as the main control unit is considered as a single-line queuing system with the FIFO (first in, first out) service discipline for the Markov flow of recoverable components' failures.

As a result, two-way estimate for the failure probability of the adaptive traffic lights is obtained and the effect of warm standby use for the traffic lights at two-way stop-controlled intersection is assessed. In the presented example waiting time for the vehicles at the intersection with adaptive controlled traffic appeared to be considerably less than in the case when there is no adaptive traffic control. It allows to highlight advantages of warm standby use as a mean to ensure the reliability of the adaptive traffic lights.

**Keywords:** Warm Standby, Reliability, Markov Flow, Adaptive Traffic Lights, Laplace Transform.

## 1 Introduction

Adaptive traffic lights are the most common and most powerful components of control in intelligent traffic management systems (ITMS). It allows actuating of time phases depending on actual traffic demand and, compared to pre-timed control, it significantly reduces traffic delays at intersections when properly configured. Though the advantages of ITMSs are obvious, ensuring the reliability of their work is not explored enough due to the absence of critical consequences when traffic lights fail, since this situation is foreseen by the traffic codes and is not a direct cause of traffic accidents. The failure of the traffic lights leads to a deterioration in the passage conditions at the intersection and an increase in vehicle delays. Pedestrians do not suffer from the failure as they receive a preferential right to cross the street via unregulated crosswalks.

Ensuring the reliability of light signaling systems is of considerable attention in railway transport, because railway signaling systems are used to ensure the safe operation of railway traffic [1, 2]. As a result, a lot of effort has gone towards ensuring the reliable operation of railway signaling systems that have to be designed to avoid single-point failures [1].

A new impetus to ensure reliability of traffic lights is added by LED (Light-Emitting Diode) arrays as a color signal emitter. LED emitters have allowed to minimize power requirements for the functioning of traffic lights, while expanding the list of standbys for their functioning with the ideal switching arrangement (warm standby), which makes it possible to increase the reliability of adaptive traffic lights in urban ITMSs.

A redundant warm standby is a very promising means of ensuring the reliability of ITMS comparing to a cold standby since traffic lights are always dispersed over fairly large territories. This leads to randomness of the recovery time of failed items, which leads to high expenditures due to the need of the repair crew to get to the failed traffic lights. Police and signal maintenance crews can often be stretched too thin when responding to power failure situations, especially in cases of concurrent failures at a large amount of intersections [3]. Throughout this time, the ITMS does not work, that causes undue delays of vehicles. At the same time, the warm reservation of traffic lights' elements allows to postpone the process of restoring its failed items until a off-peak traffic period, when it does not lead to negative consequences for road users.

By now two warm standbys for traffic lights are known: redundant LED groups to allow indication in degraded mode [4, 5] and alternative power sources as backup power to maintain normal signal operations during power outages [3]. The list can be expanded if a metric to quantify results of warm standby is defined since a cost of new units is always known and both variants of reservation are expensive enough. Transportation agencies, facing limited budgets, need decision-making support when solving the question whether the traffic operation can be improved by installing warm standbys for traffic lights – and if so, by how much.

Statistical models of road accidents [3] and a point system to score each site [6] are not a sufficient basis for making decisions in this area. The number of reported road accidents is relatively low and when traffic lights are fault there is no way to statistically quantify the expected number of accidents [6]. The point system includes traffic volume, frequency of injury accidents, proximity to a school zone, speed of approach traffic, and availability of pedestrian pre-emption controls and provides prioritization sites only [6]. The Markov technique is the most suitable for modelling road signaling systems in which the level of redundancy varies with time due to component failure and repair [1].

## **2 Laplace transform of the distribution function of the intersection busy period**

It is possible to evaluate the feasibility of warm standby use to ensure the reliability of adaptive traffic lights through obtaining quantitative estimates for both the probability

of failure of adaptive traffic lights with a different number of standbys for one operating item, and for the negative consequences of failure from the road user's point of view.

The first quantitative estimates should be obtained for the most common intersection of two nearly perpendicular roads. When traffic is controlled by traffic lights, the times of permissive phases in alternative intersecting directions are limited. Adaptive traffic control at the intersection allows switching of the permissive signal between alternative directions depending on current circumstances at the intersection. That is, when, with the permissive signal turned on in one direction  $I$ , there are no vehicles for moving in it, and the queue of vehicles is on the other direction  $II$ . Vehicles can pass through the intersection as long as they are at a given spacing or if there are no vehicles coming from the other direction, but the permissive phase should not exceed the time limit for the corresponding direction.

We have:

- $B_I^{(v(t))}(t)$  is the distribution function for the time of passing over the intersection from the start of the permissive signal in direction  $I$ ;  
 $\beta_I^{(v(t))}(s) = \int_{t>0} \exp(-st) dB_I^{(v(t))}(t)$  is the Laplace transform of this variable;
- $\Pi_I^{(v(t))}(t)$  is the distribution function for the intersection's busy period as a single-line queuing system, which begins with the  $v(I)$  vehicles' departure and the flow rate  $\Lambda_I$  of the vehicles arriving in the direction  $I$  of the intersection;
- $\pi_I^{(v(t))}(s) = \int_{t>0} \exp(-st) d\Pi_I^{(v(t))}(t)$  is the Laplace transform of this variable.

We use the additional event method according to the total probability rule. Provided that passing-over  $v(I)$  vehicles from direction  $I$  take the time  $t$ , and during this time  $t$  exactly  $n$  cars have arrived at the intersection in direction  $II$ , the conditional probability that the additional event, the rate of which equals  $s$ , does not occur during this busy period  $t$  and during the  $n$  busy periods, generated by the arrival of these  $n$  cars, is equal to  $[\pi_I^{(1)}(s)]^n \exp(-st)$ . Then we multiply it by the probability of the arrival of exactly  $n$  cars in the direction  $I$  during this busy period  $t$   
 $\frac{(\Lambda_I t)^n}{n!} \exp(-\Lambda_I t)$ .

The sum of all these multiplications  $\frac{(\Lambda_I t)^n}{n!} \exp(-\Lambda_I t) [\pi_I^{(1)}(s)]^n \exp(-st)$  for all non-negative integer numbers of incoming cars  $n \geq 0$  is equal to

$$\sum_{n \geq 0} \frac{(\Lambda_I t)^n}{n!} \exp(-\Lambda_I t) [\pi_I^{(1)}(s)]^n \exp(-st) \quad (1)$$

Then we integrate the obtained expression over all  $t > 0$  values with the distribution  $dB_i^{(\nu(I))}(t)$  for the time of passing over  $\nu(I)$  vehicles from the moment of the enabling signal in the direction  $I$  :

$$\int_{t>0} \sum_{n \geq 0} \frac{(\Lambda_i t)^n}{n!} \exp(-\Lambda_i t) [\pi_i^{(1)}(s)]^n \exp(-st) dB_i^{(\nu(I))}(t). \quad (2)$$

As a result, we obtain the equation

$$\pi_i^{(\nu(I))}(s) = \int_{t>0} \sum_{n \geq 0} \frac{(\Lambda_i t)^n}{n!} \exp(-\Lambda_i t) [\pi_i^{(1)}(s)]^n \exp(-st) dB_i^{(\nu(I))}(t). \quad (3)$$

After identical transformations we come to the following:

$$\begin{aligned} & \int_{t>0} \sum_{n \geq 0} \frac{(\Lambda_i t)^n}{n!} \exp(-\Lambda_i t) [\pi_i^{(1)}(s)]^n \exp(-st) dB_i^{(\nu(I))}(t) = \\ & = \int_{t>0} \sum_{n \geq 0} \frac{[\Lambda_i t \pi_i^{(1)}(s)]^n}{n!} \exp(-\Lambda_i t) \exp(-st) dB_i^{(\nu(I))}(t) = \\ & = \int_{t>0} \exp(-\Lambda_i t) \exp(-st) \sum_{n \geq 0} \frac{[\Lambda_i t \pi_i^{(1)}(s)]^n}{n!} dB_i^{(\nu(I))}(t) = \\ & = \int_{t>0} \exp(-\Lambda_i t) \exp(-st) \exp[\Lambda_i t \pi_i^{(1)}(s)] dB_i^{(\nu(I))}(t) = \\ & = \int_{t>0} \exp\left\{-\left[s + \Lambda_i (1 - \pi_i^{(1)}(s))\right]t\right\} dB_i^{(\nu(I))}(t). \end{aligned} \quad (4)$$

By definition, the integral  $\int_{t>0} \exp\left\{-\left[s + \Lambda_i (1 - \pi_i^{(1)}(s))\right]t\right\} dB_i^{(\nu(I))}(t)$  is equal to the Laplace transform  $\beta_i^{(\nu(I))}(s + \Lambda_i (1 - \pi_i^{(1)}(s)))$  at the point  $s + \Lambda_i (1 - \pi_i^{(1)}(s))$  :

$$\int_{t>0} \exp\left\{-\left[s + \Lambda_i (1 - \pi_i^{(1)}(s))\right]t\right\} dB_i^{(\nu(I))}(t) = \beta_i^{(\nu(I))}(s + \Lambda_i (1 - \pi_i^{(1)}(s))). \quad (5)$$

Then we have a functional equation for the Laplace transform as a result:

$$\pi_i^{(\nu(I))}(s) = \beta_i^{(\nu(I))}(s + \Lambda_i (1 - \pi_i^{(1)}(s))). \quad (6)$$

In particular, with  $\nu(I) = 1$ ,

$$\pi_i^{(1)}(s) = \beta_i^{(1)}(s + \Lambda_i (1 - \pi_i^{(1)}(s))). \quad (7)$$

By definition, it is considered that the time of the permissive phase in the direction  $I$  is limited by the value  $T_I$ . Therefore, a random variable with a distribution  $\Pi_I^{(v(I))}(t)$  of the intersection busy period limited by the value  $T_I$  to the segment  $[0; T_I]$ , which began with vehicles passing over the intersection in the direction  $I$  with the flow rate  $\Lambda_I$ , will have distribution function as follows:

$$\Pi_I^{(v(I))}[T_I](t) = \frac{\Pi_I^{(v(I))}(t)}{\Pi_I^{(v(I))}(T_I)} \cdot I(0 \leq t \leq T_I) + I(t > T_I) \quad (8)$$

and the Laplace transform

$$\pi_I^{(v(I))}[T_I](s) = \int_0^{T_I} \exp(-st) d\Pi_I^{(v(I))}[T_I](t) = \frac{\int_0^{T_I} \exp(-st) d\Pi_I^{(v(I))}(t)}{\Pi_I^{(v(I))}(T_I)}. \quad (9)$$

During the intersection busy period limited by the value  $T_I$ , which began with  $v(I)$  vehicles passing over the intersection in the direction  $I$  with the flow rate  $\Lambda_I$ , that is, during this permissive phase for vehicle direction  $I$ , some vehicles may arrive from the perpendicular direction  $II$ .

Next, we find the Laplace transform of the intersection busy period, which is formed by movement in direction  $II$  generated at the intersection by the vehicles arriving in this direction with flow rate  $\Lambda_{II}$  during the previous permissive phase for direction  $I$ , using the total probability rule according to the method of the additional event, the rate of which equals  $s$ .

Provided that passing-over  $v(I)$  vehicles from direction  $I$  take the time  $t$ , and during this time  $t$  exactly  $n$  cars have arrived at the intersection in direction  $II$ , the conditional probability that the additional event, the rate of which equals  $s$ , does not occur during this busy period  $t$  and during the  $n$  busy periods, generated by the arrival of these  $n$  cars, is equal to  $[\pi_I^{(I)}(s)]^n \exp(-st)$ . Then we multiply it by the probability of arrival of exactly  $n$  cars in direction  $II$  during this busy period  $t$   $\frac{(\Lambda_{II}t)^n}{n!} \exp(-\Lambda_{II}t)$ .

The sum of all these multiplications  $\frac{(\Lambda_{II}t)^n}{n!} \exp(-\Lambda_{II}t) [\pi_I^{(I)}(s)]^n \exp(-st)$  for all non-negative integer numbers of incoming cars  $n \geq 0$  is equal to

$$\sum_{n \geq 0} \frac{(\Lambda_{II}t)^n}{n!} \exp(-\Lambda_{II}t) [\pi_I^{(I)}(s)]^n \exp(-st). \quad (10)$$

Then we integrate the obtained expression over all  $t > 0$  with the distribution  $d\Pi_I^{(v(t))}[T_I](t)$  for the time of passing over  $\nu(I)$  vehicles from the moment of the enabling signal in direction  $I$ .

After that we integrate the obtained expression over all  $d\Pi_I^{(v(t))}[T_I](t)$  of the busy period, which began with the  $\nu(I)$  vehicles' departure and the flow rate  $\Lambda_I$  of arriving vehicles from the direction  $I$  of the intersection and limited by the value  $T_I$ :

$$\int \sum_{t>0} \sum_{n \geq 0} \frac{(\Lambda_{II} t)^n}{n!} \exp(-\Lambda_{II} t) [\pi_{II}^{(I)}(s)]^n \exp(-st) d\Pi_I^{(v(t))}[T_I](t). \quad (11)$$

As a result, we obtain the equation

$$\pi_{II}^{(v(t))}(s) = \int \sum_{t>0} \sum_{n \geq 0} \frac{(\Lambda_{II} t)^n}{n!} \exp(-\Lambda_{II} t) [\pi_{II}^{(I)}(s)]^n \exp(-st) d\Pi_I^{(v(t))}[T_I](t) \quad (12)$$

for the Laplace transform  $\pi_{II}^{(v(t))}(s) = \int_{t>0} \exp(-st) d\Pi_{II}^{(v(t))}(t)$  of the distribution of the intersection busy period in direction  $II$ , generated by vehicles arriving at the intersection in this direction with the flow rate  $\Lambda_{II}$  during the previous permissive phase for direction  $I$ .

After similar identity transformations, we have

$$\begin{aligned} \int \sum_{t>0} \sum_{n \geq 0} \frac{(\Lambda_{II} t)^n}{n!} \exp(-\Lambda_{II} t) [\pi_{II}^{(I)}(s)]^n \exp(-st) d\Pi_I^{(v(t))}[T_I](t) = \\ = \pi_I^{(v(t))}[T_I] \left( s + \Lambda_{II} (1 - \pi_{II}^{(I)}(s)) \right). \end{aligned} \quad (13)$$

We obtain an expression of the Laplace transform:

$$\pi_{II}^{(v(t))}(s) = \pi_I^{(v(t))}[T_I] \left( s + \Lambda_{II} (1 - \pi_{II}^{(I)}(s)) \right). \quad (14)$$

The equation for the function  $\pi_{II}^{(I)}(s)$  will be written below when studying the distributions of the sequence of permissive times that begins with direction  $II$ .

By the definition, it is considered that the time of the permissive phase in direction  $II$  is limited by the value  $T_{II}$ . Therefore, a random variable with distribution  $\Pi_{II}^{(v(t))}(t)$  of the intersection busy period is limited by the value  $T_{II}$  to the segment  $[0; T_{II}]$ , which begins with vehicles passing over the intersection in direction  $II$  with the flow rate  $\Lambda_{II}$  have following distribution function:

$$\Pi_{II}^{(v(t))}[T_{II}](t) = \left[ \Pi_{II}^{(v(t))}(t) / \Pi_{II}^{(v(t))}(T_{II}) \right] \cdot I(0 \leq t \leq T_{II}) + I(t > T_{II}) \quad (15)$$



and the Laplace transform equals

$$\pi_{II}^{(v(I))} [T_{II}](s) = \int_0^{T_{II}} \exp(-st) d\Pi_{II}^{(v(I))} [T_{II}](t) = \frac{\int_0^{T_{II}} \exp(-st) d\Pi_{II}^{(v(I))}(t)}{\Pi_{II}^{(v(I))}(T_{II})}. \quad (16)$$

Further we use the same set of formulas to obtain other related values.

If the process of passing over the intersection begins with cars from direction  $II$ , then the entire sequence of the distributions of limited periods of permissive phases is constructed similarly, but this time starting from direction  $II$ .

We have:

- $B_{II}^{(v(II))}(t)$  is the distribution function for the time of passing over the intersection from the start of the permissive signal in direction  $II$ ;
- $\beta_{II}^{(v(II))}(s) = \int_{t>0} \exp(-st) dB_{II}^{(v(II))}(t)$  is Laplace transform for this random variable;
- $\Pi_{II}^{(v(II))}(t)$  is the distribution function for the intersection busy period as a single-line queuing system, which began with the  $v(II)$  vehicles' departure and the flow rate  $\Lambda_{II}$  of arriving vehicles in direction  $II$  of the intersection;
- $\pi_{II}^{(v(II))}(s) = \int_{t>0} \exp(-st) d\Pi_{II}^{(v(II))}(t)$  is Laplace transform for this random variable.

Using the method of the additional event according to the formula of full probability, we have a functional equation for the Laplace transform:

$$\pi_{II}^{(v(II))}(s) = \beta_{II}^{(v(II))} \left( s + \Lambda_{II} \left( 1 - \pi_{II}^{(1)}(s) \right) \right). \quad (17)$$

In particular, with  $v(II) = 1$

$$\pi_{II}^{(1)}(s) = \beta_{II}^{(1)} \left( s + \Lambda_{II} \left( 1 - \pi_{II}^{(1)}(s) \right) \right). \quad (18)$$

By the definition, it is considered that the time of the permissive phase in direction  $II$  is limited by the value  $T_{II}$ . Therefore, a random variable with distribution  $\Pi_{II}^{(v(I))}(t)$  of the intersection busy period is limited by the value  $T_{II}$  to the segment  $[0; T_{II}]$ , which began with vehicles passing over the intersection in direction  $II$  with the flow rate

$\Lambda_{II}$ , have following distribution function:

$$\Pi_I^{(v(II))} [T_I](t) = \frac{\Pi_I^{(v(II))}(t)}{\Pi_I^{(v(II))}(T_I)} \cdot I(0 \leq t \leq T_I) + I(t > T_I) \quad (19)$$

and the Laplace transform

$$\pi_I^{(v(I))} [T_I](s) = \int_0^{T_I} \exp(-st) d\Pi_I^{(v(I))} [T_I](t) = \frac{\int_0^{T_I} \exp(-st) d\Pi_I^{(v(I))} (t)}{\Pi_I^{(v(I))} (T_I)}. \quad (20)$$

The obtained equations and recurrent expressions of Laplace transform of the sequences of durations of the permissive phases in alternative traffic directions ultimately allow paying attention to the direction of increased intensity of movement and speed of passing over the intersection, and thereby reconcile the restrictions on the times of the permission signals with the loads

$$\rho_I = \Lambda_I \int_{t>0} t dB_I^{(v(I))} (t) = \Lambda_I m^I \quad (21)$$

and

$$\rho_{II} = \Lambda_{II} \int_{t>0} t dB_{II}^{(v(II))} (t) = \Lambda_{II} m^{II} \quad (22)$$

of the corresponding directions  $I$  and  $II$  using equations (7) and (18). Differentiation of equation (7) with the opposite sign with respect to  $s$  at zero gives

$$-\frac{d}{ds} \pi_I^{(1)} (s) \Big|_{s=0} = -\frac{d}{ds} \beta_I^{(1)} (s + \Lambda_I (1 - \pi_I^{(1)} (s))) \Big|_{s=0} \quad (23)$$

using the derivative of a complex function for  $u = s + \Lambda_I (1 - \pi_I^{(1)} (s))$  and expression of first moments

$$z^I = -\frac{d}{ds} \pi_I^{(1)} (s) \Big|_{s=0} \quad (24)$$

and

$$m^I = -\frac{d}{du} \beta_I^{(1)} (u) \Big|_{u=0} \quad (25)$$

we have

$$z^I = -\frac{d}{du} \beta_I^{(1)} (u) \Big|_{u=0} \cdot \left[ 1 + \Lambda_I \left( -\frac{d}{ds} \pi_I^{(1)} (s) \Big|_{s=0} \right) \right], \quad (26)$$

or

$$z^I = m^I (1 + \Lambda_I z^I). \quad (27)$$

From this equation the expectation  $z^I$  of the period of vehicle service in direction  $I$  in the absence of restrictions ( $T_I = \infty$ ) equals

$$z^I = \frac{m^I}{1 - \rho_I}. \quad (28)$$

Similarly,

$$z^{II} = \frac{m^{II}}{1 - \rho_{II}}. \quad (29)$$

The obtained expressions for the mathematical expectations of vehicles' passing times in the absence of restrictions can be used to obtain relations for constraints  $T_I$  and  $T_{II}$ . Namely,

$$\frac{T_I}{T_{II}} = \frac{z^I}{z^{II}}, \quad (30)$$

or

$$\frac{m^I}{(1 - \rho_I)T_I} = \frac{m^{II}}{(1 - \rho_{II})T_{II}}. \quad (31)$$

The obtained Laplace transforms for travel time (7) and (18), in the absence of restrictions on the duration of the permissive phases, make it possible to determine the ratio of the values of these restrictions from a practical point of view. The absence of such restrictions, with a high total intensity of traffic flows on competing directions, will lead to undue delays for a secondary direction. Failure of the adaptive traffic lights means the removal of restrictions  $T_I$  and  $T_{II}$ .

In this regard, the study of the reliability of the adaptive traffic lights is of great interest when they are considered as recoverable systems with redundancy, which is provided by warm standby for their components.

### 3 An estimate of the probability of system failure during the regeneration period

Some elements of adaptive traffic lights may fail over time. The restoration of system elements is provided by repair facility (RF), which is a single-line queue with a FIFO service discipline. The repair times for failed elements are independent and identically distributed with distribution function  $G(x)$ . The flow of system's element failures complies with Markov chains.

If all the elements are in order, that is, the random process of servicing the failed elements is in the state  $\{0\}$ , then the failure rate of at least one element in the system

is  $\lambda(0)$ . If the system contains failed elements, then the failure rate of an element in the system is  $\lambda$ . After recovery, the element returns to where it came from. A random regeneration process of maintenance at a time  $t$  is defined by the number of serviced elements in the RF. The moments of regeneration are the times of transition of a random process to the state  $\{0\}$  when there are no requirements in RF. At the moment of transition of this random process from the state  $\{n\}$  to the state  $\{n+1\}$ , a failure occurs ( $n=1,2,\dots$ ). Let the probability of failure on the regeneration period of this random maintenance process be denoted by  $q$ . Let

$$\bar{G}(x) = 1 - G(x) \quad (32)$$

and

$$b_{n-1} = \int_0^{\infty} \lambda \frac{(\lambda x)^{n-1}}{(n-1)!} \exp(-\lambda x) \bar{G}(x) dx. \quad (33)$$

Lemma 1. Let for numbers  $a_{ij} \geq 0$ ,  $b_i > 0$ ,  $x_j > 0$ ,  $i=1,2,\dots,n$ ,  $j=1,2,\dots,n$  it is known that  $x_i \leq b_i + \sum_{j=1}^n a_{ij} x_j$  for all  $i=1,2,\dots,n$ . Then for all  $i=1,2,\dots,n$  the inequality  $x_i \leq \frac{b_i}{1-\alpha}$ , where  $\alpha = \max_{1 \leq i \leq n} \sum_{j=1}^n \frac{a_{ij} b_j}{b_i}$ , is fair.

Proof. From the lemma's condition for all  $j=1,2,\dots,n$  we have  $0 < x_j \leq b_j$ . From here, for all  $j=1,2,\dots,n$  it can be established that  $x_j = \frac{b_j}{1-\alpha_j}$ , where  $\alpha_j = 1 - \frac{b_j}{x_j}$ . If we let  $\alpha_k = \max_{1 \leq j \leq n} \alpha_j$ , the chain of relations from the condition and the last equality is fair:

$$\begin{aligned} b_k \left( 1 + \frac{\alpha_k}{1-\alpha_k} \right) &= \frac{b_k}{1-\alpha_k} = x_k \leq b_k + \sum_{j=1}^n a_{kj} x_j = b_k \left( 1 + \frac{\sum_{j=1}^n a_{kj} x_j}{b_k} \right) = \\ &= b_k \left( 1 + \frac{\sum_{j=1}^n a_{kj} \frac{b_j}{(1-\alpha_j)}}{b_k} \right) \leq b_k \left( 1 + \frac{\sum_{j=1}^n a_{kj} b_j}{b_k (1-\alpha_k)} \right). \end{aligned} \quad (34)$$

Comparing the left and right sides of these relations, we see that

$$b_k \left( 1 + \frac{\alpha_k}{1 - \alpha_k} \right) \leq b_k \left( 1 + \frac{\sum_{j=1}^n a_{kj} b_j}{b_k (1 - \alpha_k)} \right), \quad (35)$$

hence the inequalities

$$\alpha_j \leq \alpha_k \leq \sum_{j=1}^n \frac{a_{kj} b_j}{b_k} \leq \alpha = \max_{1 \leq i \leq n} \sum_{j=1}^n \frac{a_{ij} b_j}{b_i}. \quad (36)$$

are fair.

Therefore, for all  $j = 1, 2, \dots, n$  it is true that

$$x_j = \frac{b_j}{1 - \alpha_j} \leq \frac{b_j}{1 - \alpha}. \quad (37)$$

Lemma 2. For any non-negative integers  $i$  and  $j$  the inequality  $b_i b_j \leq C_{i+j}^i b_0 b_{i+j}$  is fair.

Proof. We denote

$$f(x) = \frac{\lambda \exp(-\lambda x) \bar{G}(x)}{\int_0^{\infty} \lambda \exp(-\lambda x) \bar{G}(x) dx} \quad (38)$$

and

$$M_i = \int_0^{\infty} x^i f(x) dx. \quad (39)$$

It needs to be noted that  $M_i = \frac{i! b_i}{\lambda^i b_0}$ .

Hence, a chain of relationships follow from the inequality for the moments  $M_i M_j \leq M_{i+j}$  [7]:

$$\begin{aligned} b_i b_j &= \frac{b_0^2}{i! j!} \frac{i! b_i}{\lambda^i b_0} \frac{j! b_j}{\lambda^j b_0} \lambda^{i+j} = \lambda^{i+j} \frac{b_0^2}{i! j!} M_i M_j \leq \lambda^{i+j} \frac{b_0^2}{i! j!} M_{i+j} = \\ &= \lambda^{i+j} \frac{b_0^2}{i! j!} \frac{(i+j)! b_{i+j}}{\lambda^{i+j} b_0} = C_{i+j}^i b_0 b_{i+j}, \end{aligned} \quad (40)$$

i.e.  $b_i b_j \leq C_{i+j}^i b_0 b_{i+j}$ .

We denote the conditional probability of failure during the regeneration period as  $q_r(n+1)$ , provided that at its beginning in RF there are exactly  $r$  complete requirements for the element repair,  $r = 1, 2, \dots, n-1$ .

Theorem 1. For all natural numbers  $n$ , the inequality  $q = q_1(n+1) \leq \frac{b_{n-1}}{1-b_0(2^{n-1}-1)}$  is true.

Proof. Let  $j$  denote the number of failed elements during the recovery of the first failed element in the RF busy period. Using the total probability rule, we have

$$q_1(n+1) = b_{n-1} + \sum_{j=1}^{n-1} a_j q_j(n+1). \quad (41)$$

According to the total probability rule we create the expression for the probability of failure  $q_r(n+1)$ , when at the beginning of the busy period in RF there are exactly  $r$  (at least two) full requirements:

$$q_r(n+1) = b_{n-r} + \sum_{j=0}^{n-r} a_j q_{r-1+j}(n+1), \quad 2 \leq r \leq n. \quad (42)$$

Note that  $a_0 = 1 - b_0$  and  $a_j = b_{j-1} - b_j$ ,  $j \geq 1$ .

These equalities and the Abel transform make it possible to write out and estimate, from the above formula, the second terms on the right-hand sides of the last two series of expressions, respectively, in the form

$$\begin{aligned} \sum_{j=1}^{n-1} a_j q_j(n+1) &= \sum_{j=1}^{n-1} [b_{j-1} - b_j] q_j(n+1) = \\ &= \sum_{j=1}^{n-1} b_{j-1} [q_j(n+1) - q_{j-1}(n+1)] - b_{n-1} q_{n-1}(n+1) \leq \\ &\leq \sum_{j=1}^{n-1} b_{j-1} [q_j(n+1) - q_{j-1}(n+1)] \end{aligned} \quad (43)$$

Here by definition we consider  $q_0(n+1) = 0$ ,

$$\begin{aligned} \sum_{j=0}^{n-r} a_j q_{r-1+j}(n+1) &= \sum_{j=1}^{n-r} [b_{j-1} - b_j] q_{r-1+j}(n+1) + [1 - b_0] q_{r-1}(n+1) = \\ &= \sum_{j=1}^{n-r} b_{j-1} [q_{r-1+j}(n+1) - q_{r-2+j}(n+1)] - b_{n-r} q_{n-1}(n+1) + q_{r-1}(n+1) \leq \\ &\leq \sum_{j=1}^{n-r} b_{j-1} [q_{r-1+j}(n+1) - q_{r-2+j}(n+1)] + q_{r-1}(n+1) \end{aligned} \quad (44)$$

for  $2 \leq r \leq n$ .

We denote  $\gamma_{n-j+1}(n+1) = q_j(n+1) - q_{j-1}(n+1)$ ,  $2 \leq j \leq n-1$ .

By definition  $\gamma_n(n+1) = q_1(n+1)$ . Substituting the obtained upper estimates instead of the secondary terms in the right-hand sides of the above expressions and transferring the last terms (for  $r$  equal to at least two) from right to left, we transform expressions of the probability of failures having the form of equalities into inequalities for them and their mathematical differences, respectively

$$\gamma_n(n+1) \leq b_{n-1} + \sum_{j=1}^{n-1} b_{j-1} \gamma_{n-(j-1)}(n+1) \text{ for } r=1 \tag{45}$$

and

$$\gamma_{n+1-r}(n+1) \leq b_{n-r} + \sum_{j=1}^{n-r} b_{j-1} \gamma_{n+1-r-(j-1)}(n+1) \text{ for } 2 \leq r \leq n-1. \tag{46}$$

For this system of inequalities under the conditions of Lemma 1, a square matrix of  $A = \{a_{ij}\}$  of  $(n-1)$ -th order is

$$A = \begin{pmatrix} b_{n-2}b_{n-3}b_{n-4} \dots b_1b_0 \\ b_{n-3}b_{n-4}b_{n-5} \dots b_00 \\ \dots \dots \dots \dots \dots \dots \dots \\ b_2b_1b_0 \dots \dots \dots 00 \\ b_1b_00 \dots \dots \dots 00 \\ b_000 \dots \dots \dots 00 \end{pmatrix}. \tag{47}$$

For the above system of inequalities, we can use Lemma 1 with

$$x_i = \gamma_{n+1-i}(n+1), \quad i = 1, 2, \dots, n-1. \tag{48}$$

Than from this system of inequalities according to Lemma 1

$$\gamma_n(n+1) = q_1(n+1) \leq \frac{b_{n-1}}{1-\alpha}, \tag{49}$$

where  $\alpha = \max_{1 \leq i \leq n-1} \sum_{j=1}^{n-i} \frac{b_{j-1}b_{n-j}}{b_{n-1}}$ .

According to Lemma 2 the inequality  $1 \leq j \leq n$  is true for all integers

$$b_{j-1}b_{n-j} \leq C_{n-1}^{j-1} b_0 b_{n-1} \tag{50}$$

and

$$\begin{aligned}
\alpha &= \max_{1 \leq i \leq n-1} \sum_{j=1}^{n-i} \frac{b_{j-1} b_{n-j}}{b_{n-1}} \leq \max_{1 \leq i \leq n-1} \sum_{j=1}^{n-i} \frac{C_{n-1}^{j-1} b_0 b_{n-1}}{b_{n-1}} = \\
&= b_0 \max_{1 \leq i \leq n-1} \sum_{j=1}^{n-i} C_{n-1}^{j-1} = b_0 \sum_{j=1}^{n-1} C_{n-1}^{j-1} = b_0 (2^{n-1} - 1)
\end{aligned} \tag{51}$$

Having obtained the upper bound for the value  $\alpha$ ,

$$\alpha \leq b_0 (2^{n-1} - 1). \tag{52}$$

we have also estimated the probability of system failure during the regeneration period of a random process in the redundancy model with recovery

$$q = q_1 (n+1) \leq \frac{b_{n-1}}{1 - b_0 (2^{n-1} - 1)}.$$

Let  $m_k = \int_{t>0} t^k dG(t) - k$  is the moment of service time and  $\rho = \lambda m_1 < 1$ . At the initial moment of time  $t=0$  the system is in the state  $\{0\}$  (all elements are in order). We denote by  $\tau$  the time of the first failure of the ITMS from the moment when all of its elements are in order. Theorem 1 of this paper implies the following theorem.

Theorem 2. Let there be a finite moment  $m_2 < \infty$ . Then in the process  $\frac{\lambda m_2}{m_1(1-\rho)} q \rightarrow 0$  probability

$$P \left\{ \frac{\lambda(0)(1-\rho)}{1-\rho + \lambda(0)m_1} q\tau > x \right\} \rightarrow \exp(-x). \tag{53}$$

where the two-way estimate  $q$  is true for the failure probability

$$b_{n-1} \leq q = q_1 (n+1) \leq \frac{b_{n-1}}{1 - b_0 (2^{n-1} - 1)}, \quad n = 1, 2, \dots, \tag{54}$$

that is the time until the first failure of the ITMS which has asymptotically exponential distribution. This means a higher frequency of small periods of time before the first fail and, given the large number of adaptive traffic lights in ITMSs, it indicates the importance of finding new kinds of warm standby for them.

## 4 Results

The main result of the failure probability estimation presented above is the fairness of two-sided estimate (54). For simple duplication, when  $n=1$ , this estimate gives the exact value of the probability



$$q_1(2) = b_0. \quad (55)$$

We can compare this result with result according to another method – with a similar upper estimate obtained by A.D. Solovyev in [8], where there is no subtracted unit in brackets in the denominator:

$$b_{n-1} \leq q = q_1(n+1) \leq \frac{b_{n-1}}{1-2^{n-1}b_0}. \quad (56)$$

So, the estimate of the failure probability (54) is more narrow than the estimate (56) and can provide more exact predicted reliability of traffic lights with and without warm standby. In case when the traffic lights fail with probability  $q_1$ , it is possible to estimate the effect of warm standby use for adaptive traffic lights at two-way intersection. It can be done by means of determining the difference between vehicle service time at the intersection with and without adaptive traffic control.

Comparing to the intersection with adaptive traffic control, the uncontrolled intersection with one major direction (street) has the next differences:

- vehicles on the major road have no delays when passing the intersection;
- vehicles on the minor road are obliged to slow down or even stop before entering the major road and make sure of ability to move forward without traffic hindrances on the main road.

It increases the time of passing the intersection and for vehicles on the minor road it can be estimated as  $m'' = 2m'$  [9]. Hence, an average waiting time for the vehicles on the minor (critical) movement direction can be estimated as the consequence of adaptive traffic lights failure.

For example, let the traffic volume on one lane of the major road equals to  $\lambda' = 0.3 \text{ s}^{-1}$ . Time of passing the intersection when traffic is permitted (for the major road) equals to  $m' = 2 \text{ s}$ . Analogous time for the vehicles on minor road when there is no adaptive traffic control at intersection equals to  $m'' = 2m' = 4 \text{ s}$ . Also let the traffic volume on the minor road equals to  $\lambda'' = 0.075 \text{ s}^{-1}$ . Then, when the traffic lights fail, total intersection load equals to  $\rho = \rho' + \rho'' = \lambda' m' + \lambda'' m'' = 0.6 + 0.3 = 0.9$ . Then average waiting time in a queue on the minor road [7] equals to

$$W'' = (\rho' m' / (1 - \rho) + \rho) / (1 - \rho). \quad (57)$$

After example data substitution  $W'' = [(0.6 \cdot 2) / (1 - 0.9) + 0.9] / (1 - 0.9) = 129 \text{ s}$ . The upper estimate of analogous time expenses on the minor road when there is an adaptive traffic control at intersection can be obtained regarding to restrictions from equation (31) and denoting that  $T = T_I + T_{II} = 80 \text{ s}$ . Then

$$T_{II} = [T_I(1 - \rho_I) m''] / [m'(1 - \lambda m'')] = T_I \cdot 0.4 / 0.85, \quad (58)$$

wherefrom  $T_{II} = 25.6$  s,  $T_I = 54.4$  s.

The upper estimate of waiting time is obtained upon the Smith theorem [10]:  $W'' = T_I / 2 = 27.2$  s. It means that waiting time is upper bounded by the value that is almost 5 times less than in the case when there is no adaptive traffic control at intersection. At that, average waiting time for the vehicles on the major road does not exceed the value of  $W' = T_{II} / 2 = 12.8$  s that allows to highlight advantages increasing the reliability of adaptive traffic lights by warm standby use.

## 5 Conclusions

1. The Laplace transforms (7) and (18), which were obtained for the time interval of passing over the intersection in a given direction when there are no restrictions on the duration of the permissive signal, allow the determination of the ratio of values of such restrictions from a practical point of view.
2. An upper estimate of the probability of failure of the system with one standby during the regeneration period has been found. It leads to an exact value of the probability of failure, which coincides with a lower estimate.
3. This article defines the quantitative ratios that create the opportunity to assess the feasibility of using warm standby in adaptive traffic lights, when quantitative characteristics of traffic flows and the failure rates of TMS' elements are known.

## References

1. Cèlia, N.R.: Reliability, Availability and Maintainability Study of a Light Rail Transit System. Thesis, Polytechnic University of Catalonia (2014).
2. Tang, L.: Reliability assessments of railway signaling systems: A comparison and evaluation of approaches. Thesis, Norwegian University of Science and Technology (2015).
3. Zhao, Mo: A methodology for reliability-based traffic signals alternative power capacity design. Dissertation, University of Nebraska (2015).
4. Rössner, H.: Circuit configuration for signal transmitters with light-emitting diodes. US Patent 6,069,452, 30 May 2000.
5. Oskina, M.A., Sergeev, B.S.: Резервированный светодиодный светофор (Redundant LED Traffic Lights). Patent RU 2672314, 23 Nov 2018.
6. Wallace, W.A., Wojtowicz, J., Torrey, D., Renna, N., Tan J.: Guidelines for Traffic Signal Energy Back-Up Systems. Final Report, SPR Research Project no. C-06-08. New York (2009).
7. Gnedenko, B.V., Belyaev, Yu., Solovyev, A.D.: Mathematical Methods of Reliability Theory. Academic Press, New York (1969).
8. Barzilovich, E., Beljaev, Ju., Kashtanov, V., Kovalenko, I., Solovev, A., Ushakov, I.: Вопросы математической теории надежности (The Affairs of Mathematical Theory of Reliability). Radio i svyaz, Moscow (1983).
9. Highway capacity manual. Transportation research board, Washington (2000).
10. Smith, W.L.: Regenerative stochastic processes. Proc. Roy. Soc. A 232(1188), 6-31 (1955).

# Random Re-Ordering of the Parties in the Consensus Protocol

Andrey Sobol<sup>1</sup>, Volodymyr G. Skobelev<sup>5</sup>, Julian Konchunas<sup>1</sup>, Viktor Radchenko<sup>4</sup>, Sabina Sachtachtinskagia<sup>1,3</sup>, Oleksandr Letychevskyi<sup>5</sup>, Volodymyr Peschanenko<sup>6</sup>, and Maxim Orlovsky<sup>1,2</sup>

<sup>1</sup> Pandora Core AG

<sup>2</sup> BICA Labs

<sup>3</sup> AUEB

<sup>4</sup> Garuda AI

<sup>5</sup> Glushkov Institute of Cybernetics of NAS of Ukraine

<sup>6</sup> Kherson State University

**Abstract.** Generation of a publicly verifiable bias-resistant distributed randomness is one of the actual problems in blockchain and its various applications. The complexity of this problem increases significantly for consensus algorithm operating on a decentralized network topology on the assumption that there are neither a trusted third party nor a trusted dealer. Such situation is caused by the fact that the logical structure of algorithms intended to solve the subtasks typical for this problem becomes much more complicated. Besides, there arise some subtasks caused by the complete distribution of the analyzed blockchain network. One of such nontrivial subtasks is the implementation of random re-ordering of the parties, based on generated randomness. This random reordering defines the roles of the parties in the next epoch, and is intended to support equal access of the parties to the functioning of the blockchain network. We present a simplified version of the generation of a publicly verifiable reliable distributed randomness for the consensus protocol operating on a decentralized network topology on the assumption that there are neither a trusted third party nor a trusted dealer. On this base we solve the problem of the random re-ordering for parties which will participate in the implementation of the next epoch.

**Keywords:** Distributed randomness · Public verifiability · Random re-ordering · Consensus protocols

## 1 Introduction

A completely distributed blockchain operating on a decentralized network topology on the assumption that there are no trusted third parties or dealers, can be considered as the backbone of the emerging open-access distributed Virtual Machines [1] for decentralized, token-driven resource management.

Thus, the functioning of such blockchain networks significantly relies on the performance of the used consensus mechanisms. It is worth to point out that

many of these mechanisms can be considered in terms of a uniform framework based on Zero-Knowledge (ZK) Proof systems [2]. Some survey of consensus mechanisms in blockchain networks has been presented in [3].

It is generally accepted that public verification means that any party that does not necessarily participate in the randomness generation can audit the protocol execution a posteriori with the aim to attest that the randomness source is reliable and unbiased.

The concept of a public randomness beacon that relies on a trusted third party has been proposed in [4]. The necessity to use public randomness sources effectively has increased sharply for blockchain networks [5].

An approach for generation of a distributed randomness beacon that guarantees output delivery and uniformly distributed randomness for the parties that use it, as long as a majority of them are honest, has been proposed in [6], on the assumption that a dealer participates in the proposed protocols.

An important feature of this approach is that any party that does not necessarily participate in the randomness generation can audit the protocol execution a posteriori with the aim to be convinced that the randomness source is reliable and unbiased. However the requirement of the presence of the dealer does not allow to use these constructions directly for a completely distributed network on which there is neither a trusted third party nor a dealer.

Our aim is to generate some uniformly distributed randomness for completely distributed blockchain operating on a decentralized network topology, in the assumption that there are neither the trusted third party nor the dealer, and to apply this distributed randomness for the random re-ordering of parties for the implementation of the next epoch.

## 1.1 Related Works

The basic scheme for secret sharing has been proposed in [7], and guaranties the correct output only in the case when all parties are honest. Due to constructions considered in [8], it has been established in [9] that there exists some poly-time threshold verifiable secret sharing (VSS) protocol, on the assumptions that the majority of the parties are honest and that some broadcast channel is available.

In [10] an approach to construct publicly verifiable secret sharing (PVSS) protocols has been proposed. This protocol gives the ability to the parties to verify their own shares, but also anybody can verify that the parties has received correct shares.

The model of non-interactive PVSS has been proposed in [11]. Some other PVSS schemes have been presented in [12–14]. Unfortunately, PVSS schemes, presented in [10–14], lead to high computational cost. Critical survey of these and some others PVSS has been presented in [15]. Lowering of the computational cost has been one of the main aims in protocols presented in [6].

It is well known that the randomness can be manipulated by the parties of the blockchain. To prevent these manipulations some delay functions [5, 16, 17] can be used, so that when any malicious party computes the random output, it

is too late to manipulate it. Thus, the delay function gives the chance to verify that the randomness has not been manipulated.

Hash-based signature schemes that are most often used in PVSS, are RSA [18] and ECDSA [19]. Security of these schemes are based on algebraic assumptions, i.e. security of RSA relies on the difficulties of solving the factorizing large numbers problem, while security of ECDSA relies on the difficulties of solving the discrete logarithm problem.

It is worth to note that if any of these assumptions is violated, for example, due to the development of a quantum computer, then the corresponding signature scheme is damaged forever.

The Merkle Signature Scheme [20] depends only on a secure hash function and a secure one-time signature. Some variants of this scheme has been developed: an improved Merkle signature scheme (CMSS) [21] in which two authentication trees are used, GMSS [22] which uses a scheduling strategy to precompute upcoming signatures, XMSS [23] in which a hash tree is used to reduce the authenticity of many pseudo-randomly generated one-time signature keys to one public XMSS key, XMSS-MT [24] which is a multi Tree XMSS intended to provide a large number of signatures, and SPHINCS [25] which is some many-time signature scheme that uses a hyper-tree, i.e. a tree of trees. Software implementations for some of above listed variants of Merkle Signature Scheme have been analyzed in [26].

To provide equal opportunities for an involvement of parties in a completely distributed blockchain operating on a decentralized network topology, unbiased random generation of the re-ordering for the parties can be used.

The basic algorithm, called the Fisher—Yates shuffle [27], has been presented in [28, 29], and is as follows ( $A$  is the given array with  $N$  elements, such that  $A[i] = i$  for all  $i = 1, \dots, N$ ).

```

RandomPerm( $A, N$ )
begin
  for  $i = 1$  to  $N - 1$ 
    do
      choose the integer  $j$  uniformly at random from the set  $\{i, \dots, N\}$ ;
      swap  $A[i]$  and  $A[j]$ ;
    end do
  end

```

This algorithm guarantee that the probability that  $A[i] = i$  equals to  $N^{-1}$  for any  $i \in \{i, \dots, N\}$ . Moreover, the expected number of fixed points in a random permutation equals to 1, i.e. it is independent of the integer  $N$ .

It is evident that the subtle aspect for implementation of this algorithm consists of how to choose uniformly and randomly an element of the given set. Surveys of methods proposed for generation of permutations by computer have been presented in [30, 31].

## 1.2 Our contribution

To achieve the scalability for implementation of completely distributed blockchain operating on a decentralized network topology on the assumption that there are neither a trusted third party nor a dealer, the set of parties  $\mathcal{P} = \{P_1, \dots, P_N\}$  that take the part in the implementation of the current epoch are partitioned into 3 groups  $\mathcal{P}_j = \{P_1^{(j)}, \dots, P_{n_j}^{(j)}\}$  ( $j = 1, 2, 3$ ), where  $\mathcal{P}_1$  is the set of ZK validators, and the subset  $\mathcal{P}_2$  is the set of Random Part (RP) validators. The subset  $\mathcal{P}_3$  consists of overwhelming number of parties, but these parties only take part in the commit-delay-reveal scheme pointed in the next Section.

It is assumed that  $|\mathcal{P}_2| \ll |\mathcal{P} \setminus \mathcal{P}_2|$  (for example, it is enough to consider that  $|\mathcal{P}_2| \leq 0.05|\mathcal{P} \setminus \mathcal{P}_2|$ ). The necessity of this inequality is caused by the following circumstances.

To achieve the reliability and scalability for the re-ordering of parties at regular and predictable intervals in the presence of adversarial behavior, and without any trusted dealer for the initial setup, the local sources of randomness can be used in the following way.

The sufficiently small group of parties  $\mathcal{P}_2$  independently generate their randomness on the base of some threshold random scheme which we describe below. The other parties generate their randomness with using the following commit-delay-reveal scheme:

*Step 1.* Each party from the set  $\mathcal{P} \setminus \mathcal{P}_2$  generates 32 bit random data and publish  $\text{hash}(\text{data})$ .

*Step 2.* Each party from the set  $\mathcal{P} \setminus \mathcal{P}_2$  is forced to wait for the prescribed period of time.

*Step 3.* Each party from the set  $\mathcal{P} \setminus \mathcal{P}_2$  provides its data.

Such approach gives the chance to implement the interactions in the commitment scheme as follows: during the commit phase the values of randomness are chosen and specified, while during reveal phase which starts with some admissible delay these values are revealed and checked.

Proposed threshold random scheme consists of the following three phases.

In the first phase, called the Public Key Phase, each validator from the ZK validators subset  $\mathcal{P}_1$  provides its public key (PubKey), epoch hash (EH) and the signed hash  $H(\text{PubKey}||\text{EH})$ . In the role of the hash function  $H$  can be used the Cryptographic hash function SHA256, or any other Cryptographic hash function, similar to SHA256.

In the second phase, called the Threshold Random Encrypted Part Phase each validator from the RP validators subset  $\mathcal{P}_2$  generates some random string, which is 32 byte data (thus, at our assumptions  $|\mathcal{P}_2| \ll N \ll 2^{256}$ , where  $N$  is the number of parties that take the part in the implementation of the current epoch), split this random string in accordance to Shamir's secret scheme, and encrypts each secret by the PubKey, chosen by him from Public Key Phase.

When this process is completed, each validator from the subset  $\mathcal{P}_2$  provides its list of encrypted secrets, epoch hash, and the signed hash  $H(\text{the root of merkle tree}||\text{EH})$ .

In the third phase, called Private Key Publishing Phase, each validator from the subset of the ZK validators  $\mathcal{P}_1$  provides its private key (PrKey). Each party from the subset  $\mathcal{P} \setminus \mathcal{P}_2$  reveals its random, and each party from the subset of the RP validators  $\mathcal{P}_2$  reveals its random using corresponding PrKey.

When this process is completed, each party which will participate in the implementation of the next epoch computes the random re-ordering of parties for the next epoch.

It is evident that the above described round is intended for achievement of the following purposes:

1. We should know the result of the random, i.e. that parties from the set  $\mathcal{P}_1$  have provided not less than  $50\% + 1$  of all private keys, and that parties from the set  $\mathcal{P}_2$  have presented their ciphered data.

2. If the set  $\mathcal{P}_1$  consists of less than 50% of corrupted parties, and the set  $\mathcal{P}_2$  consists of less than 100% of corrupted parties, then corrupted parties could not prevent to receive random, or to learn it in advance.

It should be noted that every time we construct new partition of the set of parties. For correctness of the proposed protocol it is necessary that the majority of parties in the set  $\mathcal{P}_1$  is honest, and at least one of the parties in the set  $\mathcal{P}_2$  is also honest. Because we constantly mix validators, these assumptions are quite realistic. It should be noted, however, that the probability that there is an honest majority in each round depends on the number of honest parties in  $\mathcal{P}$ , as well as on the shares  $\frac{|\mathcal{P}_1|}{|\mathcal{P}|}$  and  $\frac{|\mathcal{P}_2|}{|\mathcal{P}|}$ .

## 2 The random re-ordering of the parties

When the commit-delay-reveal scheme is completed, the set of the parties which will participate in the implementation of the next epoch can be formed. This set can be considered as the array consisting of the same ordering of all parties that haven't been disqualified during the current epoch, and perhaps some new parties are added to its tail.

For simplicity we denote this array  $\mathcal{P} = \langle P_1, \dots, P_N \rangle$ , and, also, we denote  $\mathcal{R} = \langle r_1, \dots, r_N \rangle$  the array of 32 byte random data that have been produced by the parties from the array  $\mathcal{P}$  in the current epoch. Assume that for each party  $P_j$  that has been unsuccessful in the commit-delay-reveal scheme, as well as for each new party  $P_j$ , its 32 byte random data  $r_j$  is the zero sequence.

To implement the random re-ordering of the elements of the array  $\mathcal{P}$  we have used the following refinement of the Fisher—Yates shuffle scheme [27, 28, 29], based on the use of some random positive integer  $M$  ( $M \gg N$ ), generated on the base of the array  $\mathcal{R}$ .

```

RanReOrd( $\mathcal{P}$ ,  $N$ ,  $M$ )
  begin
    for  $i = 1$  to  $N - 1$ 
      do
         $j := (M - i + 1)(\text{mod}(N - i + 1)) + i;$ 

```

```

        swap  $\mathcal{P}[i]$  and  $\mathcal{P}[j]$ ;
    end do
end

```

It is reasonable to make the following remark concerning the proposed above algorithm  $RanReOrd(\mathcal{P}, N, M)$ .

Since  $M$  ( $M \gg N$ ) is some random positive integer, then for any fixed integer  $i = 1, \dots, N - 1$  the integer

$$j = (M - i + 1)(\text{mod}(N - i + 1)) + i$$

is some random positive integer, such that  $i \leq j \leq N$ . This factor implies that

$$j = (M - i + 1)(\text{mod}(N - i + 1)) + i \quad (i = 1, \dots, N)$$

is some sequence of random integers. For any fixed integer  $i = 1, \dots, N - 1$  the elements  $\mathcal{P}[i]$  and  $\mathcal{P}[j]$  ( $i \leq j \leq N$ ) are swapped. Therefore at the completion of the algorithm  $RanReOrd(\mathcal{P}, N, M)$  the elements of the array  $\mathcal{P}$  are reordered in a random way.

The following two approaches intended to generate some random positive integer  $M$  ( $M \gg N$ ) on the base of the list  $\mathcal{R}$  has been checked.

The first approach is based on the computing of the binary string

$$r = \bigoplus_{i=1}^N r_i, \quad (1)$$

where  $\bigoplus$  is bit-wise XOR operation. Afterwards, the random positive integer  $M$  can be defined as the result of the transformation of the binary string  $r$  into the corresponding positive integer.

The justification that  $M$  is some random integer follows from the fact that there is the honest majority among the parties that participates in the implementation of the current epoch.

The advantage of this approach consists in the fast computing of the random positive integer  $M$ .

From our point of view, at least, the following two shortcomings are inherent into this approach.

Firstly, there can be some groups of parties, for each of which the result of the bit-wise XOR operation is the zero sequence, and, thus, these groups of parties, as a matter of fact, are eliminated from the formation of the re-ordering of parties for the next epoch.

Secondly, the corrupted parties, using these or the others unforeseen shortcomings of the delay function, can try to influence on the computation of the binary string  $r$  (see [32], for example), and, thus, on the computation of the integer  $M$ .

The second approach is based on the idea to use some well known sufficiently easily computable function  $f(x_1, \dots, x_N)$  of non-negative discrete independent random variables  $x_i$  ( $i = 1, \dots, N$ ) with the known distribution laws.



In this case, each random binary string  $r_i$  ( $i = 1, \dots, N$ ) can be transformed independently into some random non-negative integer  $m_i$ , and then we can set

$$M = \lceil f(m_1, \dots, m_N) \rceil. \quad (2)$$

Proceeding from the probabilistic reasons, the most expedient choice is the function

$$f(x_1, \dots, x_N) = N^{-1} \sum_{i=1}^N x_i, \quad (3)$$

where  $x_i$  ( $i = 1, \dots, N$ ) are non-negative discrete independent random variables with the known distributions. Due to this function, the integer  $M$  can be computed as follows.

Each binary string  $r_i$  ( $i = 1, \dots, N$ ) can be transformed into the corresponding non-negative integer  $m_i$ . Thus, formulae (2) and (3) imply that

$$M = \lceil N^{-1} \sum_{i=1}^N m_i \rceil. \quad (4)$$

Since  $r_i$  ( $i = 1, \dots, N$ ) are random values that are uniformly chosen from the set  $\{0, 1, 2^{256} - 1\}$ , we deal with the function (3) under the supposition that each  $x_i$  ( $i = 1, \dots, N$ ) is the uniformly distributed random variable on the consecutive integers  $0, 1, 2^{256} - 1$ .

Thus, for each random variable  $x_i$  ( $i = 1, \dots, N$ ) the mean equals to

$$\mathbf{E}(x_i) = 0.5(2^{256} - 1), \quad (5)$$

and the variance equals to

$$\mathbf{Var}(x_i) = \frac{2^{512} - 1}{12}. \quad (6)$$

Formulae (5) and (6), taking into account the properties of the mean and the variance imply that for the random variable

$$X = N^{-1} \sum_{i=1}^N x_i \quad (7)$$

we get

$$\begin{aligned} \mathbf{E}(X) &= \mathbf{E} \left( N^{-1} \sum_{i=1}^N x_i \right) = N^{-1} \sum_{i=1}^N \mathbf{E}(x_i) = N^{-1} \sum_{i=1}^N 0.5(2^{256} - 1) = \\ &= 0.5(2^{256} - 1)N^{-1} \sum_{i=1}^N 1 = 0.5(2^{256} - 1)N^{-1}N = 0.5(2^{256} - 1), \quad (8) \\ \mathbf{Var}(X) &= \mathbf{Var} \left( N^{-1} \sum_{i=1}^N x_i \right) = N^{-2} \sum_{i=1}^N \mathbf{Var}(x_i) = N^{-2} \sum_{i=1}^N \frac{2^{512} - 1}{12} = \end{aligned}$$

$$= N^{-2} \cdot \frac{2^{512} - 1}{12} \cdot \sum_{i=1}^N 1 = N^{-2} \cdot \frac{2^{512} - 1}{12} \cdot N = \frac{2^{512} - 1}{12N}. \quad (9)$$

Formula (9), in its turn, implies that for the standard deviation of the random variable  $X = N^{-1} \sum_{i=1}^N x_i$  the following formula is true

$$\sigma_X = \sqrt{\frac{2^{512} - 1}{12N}}. \quad (10)$$

It should be noted that formulae (8)-(10) represent probability-theoretic characteristics of the random variable  $X$ , defined by formula (7). Unfortunately, no probability-theoretic characteristics of the random variable constructed according to the formula (1) are known to us.

### 3 Conclusion

In the given paper we have proposed some approaches for the solution of the problem of random re-ordering for parties which will participate in the implementation of the next epoch in the completely distributed blockchain operating on a decentralized network topology on the assumption that there are neither a trusted third party nor a dealer. The results of experiments has shown that time needed for computing the re-ordering is acceptable for both proposed approaches.

Comparative analysis of efficiency for different well known sufficiently easily computable functions  $f(x_1, \dots, x_N)$  of non-negative discrete integer-valued independent random variables  $x_i$  ( $i = 1, \dots, N$ ) form some trend for future research.

Another trend for future research consists of comparable analysis for characteristics of these re-orderings for parties to resist to these or other actions of the corrupted parties. For the solution of this problem it is supposed to use the System of insertion modeling and symbolic verification of large systems [33].

**Acknowledgements.** We thank an anonymous referee for carefully reading a preliminary version of this paper, for pointing out some slips made in it, and for posing questions that have led to improvements of the presentation.

### References

1. Kosba A., Miller A., Shi E., Wen Z., and Papamanthou C.: Hawk: The blockchain model of cryptography and privacy-preserving smart contracts. In: 2016 IEEE Symposium on Security and Privacy (SP), San Jose, CA, pp. 839–858 (2016). <https://doi.org/10.1109/SP.2016.55>
2. Wu H., and Wang F.: A Survey of noninteractive zero knowledge proof system and its applications. The Scientific World Journal, vol. 2014, Article ID 560484, 7 pages (2014) <https://doi.org/10.1155/2014/560484>

3. Wang W., Hoang D.T., Xiong Z., Niyato D., Wang P., Hu P., and Wen Y.: A Survey on consensus mechanisms and mining management in blockchain networks. <https://arxiv.org/pdf/1805.02707.pdf>
4. Rabin M.O.: Transaction protection by beacons. *J. Comput. Syst. Sci.*, **2**(27), pp. 256–267 (1983)
5. Bonneau J., Clark J., Goldfeder S.: On bitcoin as a public randomness source. *Cryptology ePrint Archive*, Report 2015/1015 (2015), <http://eprint.iacr.org/2015/1015>
6. Cascudo I., David B.: SCRAPE: Scalable randomness attested by public entities. In: Gollmann D., Miyaji A., and Kikuchi H. (eds.) *ACNS 2017*, LNCS, vol. 10355, pp. 537–556. Springer, Heidelberg (2017). [https://doi.org/10.1007/978-3-319-61204-1\\_27](https://doi.org/10.1007/978-3-319-61204-1_27)
7. Shamir A.: How to share a secret. *Communications of the ACM*, **22**(11), pp. 612–613 (1979)
8. Chor B., Goldwasser S., Micali S.: Verifiable secret sharing and achieving simultaneti in the presence of faults (extended abstract). In: *Proc. 26<sup>th</sup> IEEE Symposium on Foundations of Computer Science (FOCS)*, pp. 383–395. IEEE Computer Society Press (1985)
9. Rabin T., Ben-Or M.: Verifiable secret sharing and multiparty protocols with honest majority (extended abstract). In *21<sup>st</sup> ACM STOC*, pp. 3–85. ACM Press (1989)
10. Stadler M.: Publicly verifiable secret sharing. In: Maurer, U. M. (eds.) *EUROCRYPT’96*, LNCS, vol. 1070, pp. 190–199. Springer, Heidelberg (1996). [https://doi.org/10.1007/3-540-68339-9\\_17](https://doi.org/10.1007/3-540-68339-9_17)
11. Schoenmakers B.: A simple publicly verifiable secret sharing scheme and its application to electronic voting. In: Wiener M. (eds) *CRYPTO’99*, LNCS, vol. 1666, pp. 148–164. Springer, Berlin, Heidelberg (1999). [https://doi.org/10.1007/3-540-48405-1\\_10](https://doi.org/10.1007/3-540-48405-1_10)
12. Boudot F., Traoré J.: Efficient publicly verifiable secret sharing schemes with fast or delayed recovery. In: Varadharajan V., and Mi Y. (eds) *ICICS 99*, LNCS, vol. 1726, pp. 87–102. Springer, Heidelberg (1999). [https://doi.org/10.1007/978-3-540-47942-0\\_8](https://doi.org/10.1007/978-3-540-47942-0_8)
13. Heidarvand S., Voillar J.L.: Public verifiability from parings in secret sharing schemes. In: Avanzi R.M., Keliher L., and Sica F. (eds) *SAC 2008*, LNCS, vol. 5381, pp. 294–308, Springer, Heidelberg (2009). [https://doi.org/10.1007/978-3-642-04159-4\\_19](https://doi.org/10.1007/978-3-642-04159-4_19)
14. Jhanvar M.P.: A practical (non-interactive) publicly verifiable secret sharing scheme. In: Bao F., and Weng J. (eds) *ISPEC 2011*, LNCS, vol. 6672, pp. 273–287, Springer, Berlin, Heidelberg (2011). [https://doi.org/10.1007/978-3-642-21031-0\\_21](https://doi.org/10.1007/978-3-642-21031-0_21)
15. Peng K.: Critical survey of existing publicly verifiable secret sharing schemes. *IET Information Security* **6**(4), pp. 249–257 (2012) <https://doi.org/10.1049/iet-ifs.2011.0201>
16. Lenstra A.K., and Wesolowski B.: A random zoo: sloth, unicorn, and trx. *IACR Cryptology ePrint Archive*, Report 2015/366 (2015) <https://eprint.iacr.org/2015/366>
17. Bünz B., Goldfeder S., and Bonneau J.: Proofs-of-delay and randomness beacons in Ethereum (2017). [http://www.jbonneau.com/doc/BGB17-IEEEESB-proof\\_of\\_delay\\_ethereum.pdf](http://www.jbonneau.com/doc/BGB17-IEEEESB-proof_of_delay_ethereum.pdf)
18. Rivest R.L., Shamir A., and Adleman L.: A method for obtaining digital signatures and public-key cryptosystems. *Commun. ACM*, **21**(2), pp. 120–126, (1978)

19. Johnson D., Menezes A., and Vanstone S.: The elliptic curve digital signature algorithm (ecdsa). *International Journal of Information Security*, **1**(1), pp. 36–63 (2001)
20. Merkle R. C.: A certified digital signature. In: Brassard G. (eds) *Advances in Cryptology — CRYPTO’ 89*, LNCS, vol. 435, pp. 218–238, Springer, New York, NY (1989). [https://doi.org/10.1007/0-387-34805-0\\_21](https://doi.org/10.1007/0-387-34805-0_21)
21. Buchmann J., Garcia L.C.C., Dahmen E., Doring M., and Klintsevich E.: CMSS – an improved merkle signature scheme. In: Rana Barua R., and Lange T. (eds) *INDOCRYPT 2006*, LNCS, vol. 4329, pp. 349–363, Springer-Verlag, Berlin, Heidelberg (2006). [https://doi.org/10.1007/11941378\\_25](https://doi.org/10.1007/11941378_25)
22. Buchmann J., Dahmen E., Klintsevich E., Okeya K., and Vuillaume C.: Merkle signatures with virtually unlimited signature capacity. In: Katz J., and Yung M. (eds) *ACNS 2007*, LNCS, vol. 4521, pp. 31–45, Springer-Verlag, Berlin, Heidelberg (2007). [https://doi.org/10.1007/978-3-540-72738-5\\_3](https://doi.org/10.1007/978-3-540-72738-5_3)
23. Buchmann J., Dahmen E., and Hulsing A.: XMSS - a practical forward secure signature scheme based on minimal security assumptions. In: Yang B.Y. (eds) *PQCrypto 2011*, LNCS, vol. 7071, pp. 117–129, Springer, Berlin, Heidelberg (2011). [https://doi.org/10.1007/978-3-642-25405-5\\_8](https://doi.org/10.1007/978-3-642-25405-5_8)
24. Hulsing A., Rausch L., and Buchmann J.: Optimal parameters for XMSS-MT. In: Cuzzocrea A., Kittl C., Simos D.E., Weippl E., Xu L. (eds) *CDARES 2013*, LNCS, vol. 8128, pp. 194–208, Springer, Berlin, Heidelberg (2013). [https://doi.org/10.1007/978-3-642-40588-4\\_14](https://doi.org/10.1007/978-3-642-40588-4_14)
25. Bernstein D.J., Hopwood D., Hulsing A., Lange T., Niederhagen R., Papachristodoulou L., Schneider M., Schwabe P., and WilcoxO’Hearn Z. SPHINCS: practical stateless hash-based signatures. In: Oswald, E., Fischlin, M. (eds.) *EUROCRYPT 2015*, LNCS, vol. 9056, pp. 368–397. Springer, Heidelberg (2015). [https://doi.org/10.1007/978-3-662-46800-5\\_15](https://doi.org/10.1007/978-3-662-46800-5_15)
26. de Oliveira A.K., López J., and Cabral R.: High performance of hash-based signature schemes. *International Journal of Advanced Computer Science and Applications*, **8**(3), pp. 421–432 (2017)
27. Fisher R. A., and Yates F.: *Statistical tables for biological, agricultural and medical research*, Oliver & Boyd, London (1938)
28. Durstenfeld R.: Algorithm 235: random permutation. *Communications of the ACM*, **7**(7), p. 420 (1964) <https://doi.org/10.1145/364520.364540>
29. Knuth D.E.: *The Art of computer programming, third edition, Vol. 2: Seminumerical algorithms*, Addison-Wesley, Reading, MA (1997)
30. Sedgewick R.: Permutation Generation Methods. *Computing Surveys*, **9**(2), pp. 137–164 (1977)
31. Barcher A., Bodini O., Hwang H.K., and Tsai T.H.: Generating random permutations by coin-tossing: classical algorithms, new analysis and modern implementation. *ACM Transactions on Algorithms*, **13**(2), Article No. 24 (2017) <https://doi.org/10.1145/3009909>
32. Syta E., Jovanovic P., Kogias E.K., Gailly N., Gasser L., Khoffi I., Fischer M.J., and Ford B.: Scalable bias-resistant distributed randomness. *IACR Cryptology ePrint Archive: Report 2016/1067* (2017) <https://www.ieee-security.org/TC/SP2017/papers/413.pdf>
33. Letichevsky A.A., Letichevskiy O.A., Peschanenko V.S., Weigert T.: Insertion modeling and symbolic verification of large systems. In: *SDL 2015: Model-Driven Engineering for Smart Cities*, LNCS, vol. 9369, pp. 3-18. Springer-Verlag Berlin, Heidelberg (2015). [https://doi.org/10.1007/978-3-319-24912-4\\_1](https://doi.org/10.1007/978-3-319-24912-4_1)

# Optimization of Flows and Flexible Redistribution of Autonomous UAV Routes in Multilevel Airspace

Tetiana Shmelova<sup>1</sup>[0000-0002-9737-6906], Arnold Sterenharz<sup>2</sup>[ 0000-0003-3942-1227 ],

Oleksandr Burlaka<sup>3</sup>[ 0000-0002-8883-6130]

<sup>1</sup>National Aviation University, Komarova av., 1, 03058, Kiev, Ukraine  
shmelova@ukr.net

<sup>2</sup>ECM Space Technologies GmbH (ECM), Germany  
arnold.sterenharz@ecm-office.de

<sup>3</sup>National Aviation University, Komarova av., 1, 03058, Kiev, Ukraine  
wrkttt@gmail.com

**Abstract.** The authors present a problem of the performance of Unmanned Aerial Vehicles (UAV)'s flights (group or single flight) for the decision of different target tasks in the city using information air navigation technology and methods of mathematical modeling in Artificial Intelligence (graph theory, Expert Judgment Method, methods of decision making in risk and fuzzy-logic, dynamic programming, etc.). The configuration and optimization of group flight routes for UAVs depend on the type of "target task". The algorithm of estimation performance of UAVs flights in the smart-town, an illustrative example of the optimization of UAVs flights is presented in the article.

**Keywords:** Unmanned Aerial Vehicle, Remotely Piloted Aircraft System, Topology, GRID-analyze, Decision Making in Risk, Dynamic Programming, Smart City.

## 1 Introduction

Remotely piloted aircraft systems (RPAS) are a new component of the aviation system. They are based on cutting-edge developments in aerospace technologies, which may open new applications; improve to the safety and efficiency of aviation [1; 2].

Unmanned Aerial Vehicles (UAV)'s have several advantages, namely low operating cost, simplicity, availability, UAVs may be used in cases where the usage of manned aircraft is impractical, expensive or dangerous [3; 4]. Nowadays using of UAVs is effective for decision lot problems such as in monitoring forest fires; search and rescue operations; for relay communications in those places - where the antenna coverage cannot be set because of difficult terrain; in logistic as the safest, cheap and fast method of movement of goods; for aerial photography; for controlling traffic; for first aid to people under various extreme conditions, etc. [3; 4; 5]. Many of these tasks decision for an urban locality and wherein effectively use single and group flight of

UAVs [6; 7]. The Forum "Urban Air Mobility" in November 2018 at Amsterdam discussed the future of drones in cities. Looked at from the perspective of cities and citizens, urban air mobility and the idea of Mobility as a Service (MaaS) provide a fascinating view of a possible future where a daily commute could seamlessly include a bicycle, train, and drone service all as part of an integrated public transportation system [8]. In this sense, the usage of group flights UAVs is more appropriate, for example, for photo/video monitoring; group survey of large areas and patrol areas; delivery of big number cargo and use of an unmanned taxi to move passengers, etc. Noted additional useful properties such as faster coverage of big area fragment of urban and minimal risk in the movement of UAVs in town as in "smart-city". Therefore, the disadvantages of UAV's that include the limited capacity due to the small size of UAV can be satisfied with the group flight usage [6].

When planning UAV flights, it is important to comply with regulatory air navigation requirements and effective methods for flight operations [1; 2; 9]. The documents of ICAO are including the requirements and UAV management rules such as UAV certification and operator certification; UAV registration; rules for UAV operations; communication with the UAV; training of personnel for the operation of the UAV; emergency situations with UAV and flight safety; legal issues to ensure the possibility of performing safe, coordinated and effectively integrated flights UAVs [1; 2].

*The purposes of the work* are:

- building an Expert system (ES) as Artificial Intelligence (AI) for estimation of the performance of UAVs flights (group and single) for the decision of different target tasks in an urban locality;
- definition safe and minimal cost ways UAVs movement in town.

## **2 Flexible redistribution of autonomous Unmanned Aircraft routes in multilevel airspace**

### **2.1 Expert systems for estimation performance of UAVs flights in smart-town**

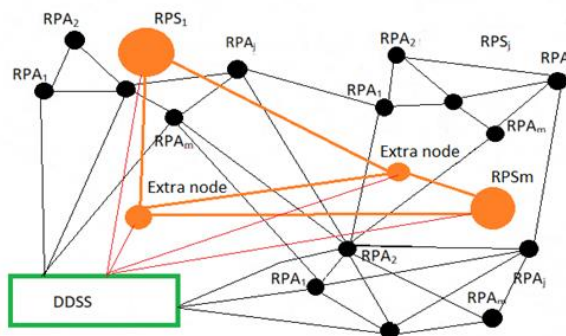
The concept of "smart city" is characterized by using the new achievements for the effective organization of life in a town. This is using AI as UAVs and Expert systems; Internet technologies in order to monitor the state of urban infrastructure facilities, their control, and based on the data obtained because of monitoring, optimal allocation of resources and ensuring the safety of citizens. Such objects include bridges and tunnels, roads and railways, communication systems, water supply, and drainage systems, power supply systems, and various large industrial facilities, airports, rail railway stations, seaports, etc. [4; 9].

The effectiveness of presenting using UAVs for a modern town as a "smart city" has some problems: the presence of buildings, roads, construction, recreation areas, and natural areas, etc.; availability of specific flight orders - target use of drones [9]; air navigation requirements [1; 2] for flight operations of the manned and unmanned aircraft, etc. The "smart city" is an aggregate of several information and communication technologies, mathematical methods and AI. The usage of UAVs in the smart city concept will help solve such tasks: traffic jams monitoring; search and rescue tasks;

photo/video monitoring; the mobile point of Wi-Fi retranslating; the movement of goods; taxing operations; ambulance operations, etc.

Using graph theory can determine the effectiveness of different structures (topologies) in UAV's group formation. To control a group of drones from RPAS suggested choosing and using a Central Drone Repeater (CDR) to connect to the operator on the ground and control the other of the UAVs using the method of server selection in local computer networks [6; 10]. For planning and flight control UAV developed a Distributed Decision Support System (DDSS), which represents a complex system with complex interactions geographically distributed local Remote piloted aircraft (RPA). During the flight UAVs may be controlled by remote piloting station (RPS). At any given time  $t_i$   $k$ -UAV must piloted by only one  $j$ -th RPS, if necessary, at time  $t_{i+1}$  to be transmitted to the control  $(j + 1)$ -th RPS (fig. 1). This transfer flight control of the  $j$ -th RPS to  $(j + 1)$ -th RPS to be safe and effective, which is provided through the local operators UAV. To coordinate interaction and exchange of information between remotod pilots developed a database of local RPS NoSQL [6].

The authors have developed computer programs for DDSS of the unmanned aircraft pilot, "Remote Expert Air Traffic Management System "Decision making (DM) in a common environment FF-ICE (Flight & Flow Information for a Collaborative Environment (FF-ICE))" presented decentralized-distributed UAVs control system using blockchain technology for connection between RPS and RPA (Fig.1). Blockchain technology is ideal as a new infrastructure to secure, share, and verify learning achievements and Collaborative Decision Making (CDM) too. For today, the key to ensuring the safety of flights is the problem of the organization of CDM by all the operational partners based on general information on the flight process and ground handling of the manned and unmanned aircraft [11]. There are many advantages of this approach such as enhanced security, security, big data analysis, and record keeping, real-time constant data exchange, etc.



**Fig. 1.** Decentralized-distributed UAVs control system with blockchain connection between RPA

For the management of the UAV, a system for managing single or a group of the UAV's is proposed, depending on the purpose of the UAV ("target task"). Taking into

account the limited and dependence of the use of the UAV group on its intended purpose were analysed the network topology indicators for the implementation of the group flight. The Algorithm of building an Expert system (ES) for estimation of the performance of UAVs flights (group and single) for the decision of different target tasks in an urban locality:

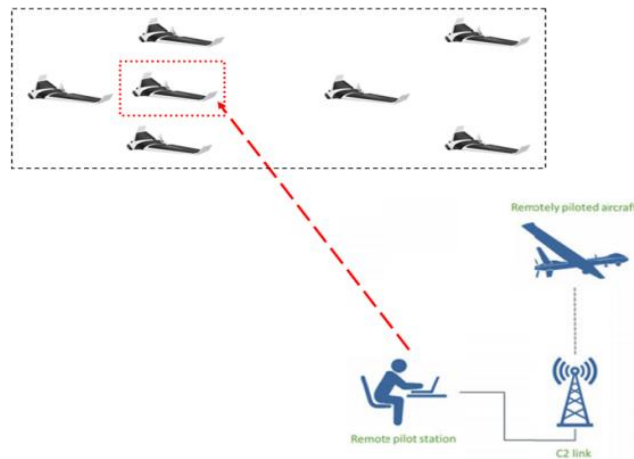
1. *The estimation* effectiveness performance the target task of using the next systems: the group of separate UAVs with controls from separate operators; the UAVs group with control from CDR-UAV; single UAV with control single operator. If there is the UAV group with control from CDR need:

- a. Decomposition of the complex system on subsystems “network topologies - the target tasks”, description of the characteristics of subsystems, and estimation of effectiveness of network topologies for performance the specific target task.
- b. The effectiveness of network topologies for performance the target task and definition of criteria estimation (definition the corresponding weight coefficients of the efficiency of the topology).
- c. Estimation of network topologies of the UAV group for the specific target task using Expert Judgment Method (EJM) (definition of system preferences and coordination of experts’ opinions too).

2. *Estimation* of urban locality using GRID analyses of sector UAV flight, fuzzy-logic or EJM for estimation of risk/safety of UAV flight.

3. *Aggregation* of subsystems to the new system (additive or multiplicative aggregation depend on the type of "target task").

4. *Graphical presentation* of results for Expert System (group UAV, single UAV or group of single UAVs), for example, estimation of effectiveness of network topologies for performance the target task “monitoring” by UAVs group” (Fig.2).



**Fig. 2.** Control system of UAV’s group from RPAS using CDR-drone

To evaluation, the safety of UAVs flights in town, need to obtain quantitative values of risks of flights in different segments of the territory of the town using methods



for evaluating risk/safety (EJM or Fuzzy logic) [13] and according to air navigation requirements [1; 2].

The air navigation rules for classification obstructions in town such as “Restricted” and “Dangerous” areas, but they have nothing in common with ICAO’s official definitions, this is an estimation of risks movement ways of UAVs in smart-city. The “Restricted areas” in our case are such areas, where the risk of harming people is high, the “Dangerous areas” - the risk of harming people is very high. Initial data for estimation risk:

*a). Buildings.* These are objects where people live and work (offices, factories, markets) and public places. Potential risk after these area penetrations: for UAVs - very high; for people - moderate to high.

*b). Columns and wired communication.* These objects are columns with its wires, masts, pipes antennas, which may endanger life and health of people nearby in case of breakdown. Potential risk after area penetration: for UAVs - moderate; for people - low to moderate.

*c). Trees and natural obstructions:* These objects are trees, hills, mountains etc. Potential risk after area penetration: for UAVs - high to very high; for people - very low.

*d). Dangerous areas* are classified on the basis of an application to the object of “Restricted area”. “Dangerous areas” themselves are not hazardous, but permanent residence increases the risk directly proportional to the residence time. Potential risk at the moment of penetration: for UAVs - very low; for people - very low.

*e). The potential risk* when UAVs is staying in any period of time is a very complex task and depends on many factors, such as time, enclosing object, the previous trajectory of flight, maneuverability of UAVs, aerodynamic aspects, environmental conditions, etc.

*f). Track area.* It is a part of the planned flight path after UAV flight in which 99.99% UAV is or will be located according to “Flight plan” data: for UAVs - high to very high; for people - high to very high.

*g). Track conflict area:* It is unplanned part of space around “Track area”: for UAVs - high to very high; for people - high to very high.

The results of values of risk/safety estimation of UAV flights in the city presented in Table 1. For example, risk of UAV flight in a restricted area equal to ten conventional units (multiplication the hazard/safety flight weight by the expected damage).

**Table 1.** Results of areas estimation in risk using EJM.

Obstruction	Name and code	Code	Value of Risk
Track	Track area	TA	50
Track	Track Conflict area	TCA	25
Track- Flight	Flight UAV	FA	1
Restricted area	Building	B-RA	10
Restricted area	Columns and wired communication	C-RA	9
Restricted area	Trees and natural obstructions	N-RA	8
Restricted area	Horizontal buffering area	HBA	7
Restricted area	Vertical buffering area	VBA	5

Fuzzy logic methods have been applied to assess risk levels and is based on the logical rules "IF (condition) - TO (conclusion)" [13]. In this case, the corresponding probabilities of events and the size of possible outcomes are considered as Fuzzy sets  $P_j$  and  $L_{ij}$ , membership functions  $\mu(P_j), \mu(L_{ij})$ . Risk  $R$  is determined as:

$$R = \mu(P_j) \times \mu(L_{ij})$$

The qualitative risk level indicator includes next characteristics of risk, namely:

1. "Very low risk" corresponds to the flight of UAV.
2. "Low risk" corresponds to restricted areas such as columns and wired communication;
3. "Average risk" corresponds to restricted areas such as a building;
4. "High risk" corresponds to dangerous areas;
5. "Very high risk" corresponds to the tracks area by busy of UAV.

The degree of belonging of a certain value determined as the ratio of the number of responses in which the value of the linguistic variable occurs in a certain interval, to the maximum value of this number in all intervals.

Experts were interviewed by the Delphi method in two rounds. There are 35 experts attend the survey. The results of the survey are listed in Table 4. Units of intervals – 1 for 0 - 0,1; 2 for 0,1- 0,2, 3 for 0,2- 0,3,etc.

**Table 2.** The results of the survey are listed

	Interval, units									
Value	1	2	3	4	5	6	7	8	9	10
1	18	16	5	1	0	0	0	0	0	0
2	0	8	20	11	1	0	0	0	0	0
3	0	0	0	7	17	12	4	0	0	0
4	0	0	0	0	0	0	2	23	15	0
5	0	0	0	0	0	0	0	7	9	24
kj	18	24	25	19	18	12	6	30	24	24

To process the data, using a matrix of prompts, which is a string with the elements defined by the formula:

$$k_j = \sum_{i=1}^5 b_{ij}, \quad j = \overline{1, 10}.$$

The matrix of prompts in our case has the form:

$$M = \parallel 18 \quad 24 \quad 25 \quad 19 \quad 18 \quad 12 \quad 6 \quad 30 \quad 24 \quad 24 \parallel$$

Choose from the matrix of prompts the maximum element and convert the elements of table 2 according to the formula:

$$k_{\max} = \max_j k_j = \max \{18; 24; 25; 19; 18; 12; 6; 30; 24; 24\} = 30$$

$$c_{ij} = \frac{b_{ij}k_{\max}}{k_j}$$

The results of calculations are included in the Table 3, based on which the functions of membership will be built.

**Table 3.** The results of calculations based on which the functions of membership will be built

	Interval, units									
Value	1	2	3	4	5	6	7	8	9	10
1	30,0	20,0	6,0	1,6	0,0	0,0	0,0	0,0	0,0	0,0
2	0,0	10,0	24,0	17,4	1,7	0,0	0,0	0,0	0,0	0,0
3	0,0	0,0	0,0	11,1	28,3	30,0	20,0	0,0	0,0	0,0
4	0,0	0,0	0,0	0,0	0,0	0,0	10,0	23,0	18,8	0,0
5	0,0	0,0	0,0	0,0	0,0	0,0	0,0	7,0	11,3	30,0

The maximum elements in each line are finding as:

$$c_{i\max} = \max_j c_{ij}, \quad i = 1, 2, \dots, m, \quad j = 1, 2, \dots, n$$

$$c_{1\max} = 25,0; c_{2\max} = 21,0; c_{3\max} = 25,0; c_{4\max} = 21,4; c_{5\max} = 25,0.$$

The value of the membership function is determined by the formula:

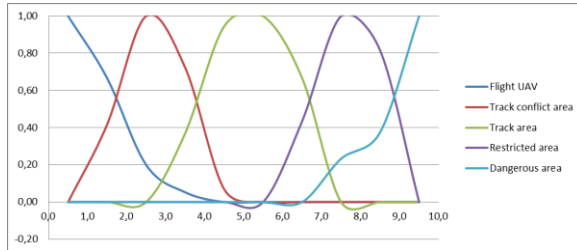
$$\mu = \frac{\hat{n}_{ij}}{c_{i\max}}$$

The results of calculations are shown in the Table 4.

**Table 4.** The results of experts' opinion

	Interval, units									
Value	1	2	3	4	5	6	7	8	9	10
FA	1,00	0,67	0,20	0,05	0,00	0,00	0,00	0,00	0,00	0,00
TCA	0,00	0,42	1,00	0,72	0,07	0,00	0,00	0,00	0,00	0,00
TA	0,00	0,00	0,00	0,37	0,94	1,00	0,67	0,00	0,00	0,00
RA	0,00	0,00	0,00	0,00	0,00	0,00	0,43	1,00	0,82	0,00
Dangerous area	0,00	0,00	0,00	0,00	0,00	0,00	0,00	0,23	0,38	1,00

The membership functions for estimation of risk were obtained based on experimental data. Assume that the minimum risk level is zero units and the maximum is 100 units respectively. The fuzzy-logic functions of estimation in risk moving UAVs in flight, track conflict area, track area, restricted area, and dangerous area in Fig.3 (after the first round of the poll).



**Fig. 3** Fuzzy-logic function of estimation risk

From the resulting diagrams, determined the quantitative indicators that correspond to the values of the linguistic variable "risk level"(after the second round of the poll):

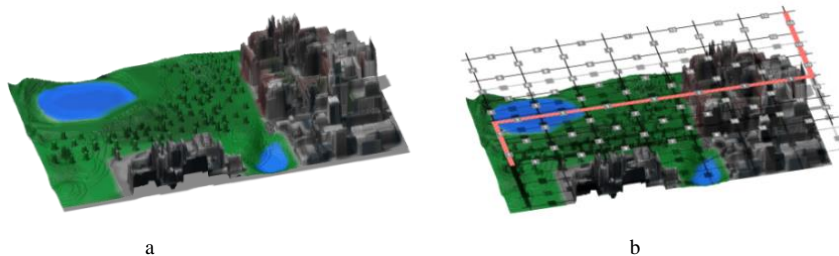
- “Very low risk” corresponds to the quantitative significance of the level of risk in 10.
- “Low risk” corresponds to the quantitative significance of the level of risk in 35;
- “Average risk” corresponds to the quantitative significance of the level of risk in 60;
- “High risk” corresponds to the quantitative significance of the level of risk in 80;
- “Very high risk” corresponds to the quantitative significance of the level of risk in 100.

## 2.2 Definition minimal cost and safety of UAVs movement ways in town

The mathematical methods such as the Dynamic Programming (DP), EJM, and fuzzy logic for estimation risks and minimal cost of ways of moving. For a definition, minimal cost and safety of UAVs movement ways in smart-city of town may use mathematical methods and modern air navigation rules. Estimation of an area in a fragment of the territory in fig.4a. Algorithm of definition minimal cost and safety of UAVs movement ways in town next:

- 1) Grid-analysis - cells are superimposing on a fragment of terrain (Fig.4b).
- 2) Risk assessment of Grid cells depending on the type of area (“Restricted” or “Dangerous”).
- 3) Finding the minimum cost path  $W_l$  for a UAV<sub>1</sub> using the DP method for planning a flight in a level  $L_l$ :

$$W_l(y_i) = y_{i-1}(RA; BA; TA; TCA; FA) + \min(y_i(RA; BA; TA; TCA; FA))$$

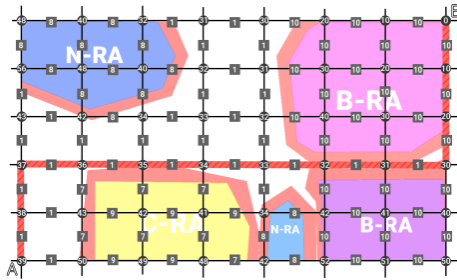


**Fig. 4** Fragment of the territory for estimation minimal cost and safety of UAVs movement

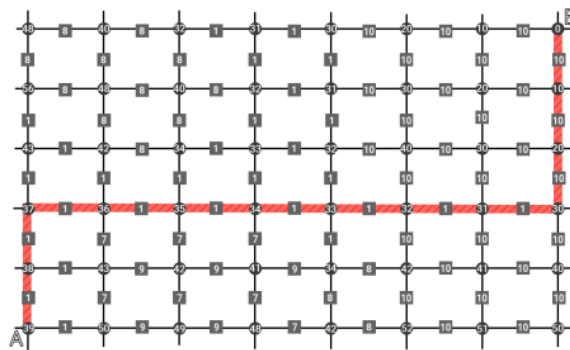
Assessing the path  $W_1$  (level  $L1$ ) of the UAV<sub>1</sub> as “Dangerous”;

4) Finding the minimum cost path  $W_2$  for a UAV<sub>2</sub> using the DP method for planning a flight in a level  $L1$ , if necessary, the transition to the level  $L2$ , etc.

For example, estimation and finding the minimum cost path  $W_1$  for a UAV<sub>1</sub> on Fig.5, and the minimum cost path  $W_1$  for a UAV<sub>1</sub> on Fig.6 ( $W_1=39$ ).

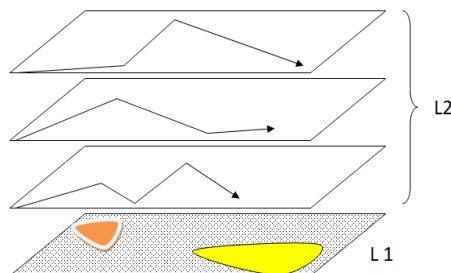


**Fig. 5** Risk assessment of Grid cells



**Fig. 6** The minimum cost path  $W_1$  for a UAV<sub>1</sub>.

The transfer of a UAV flight from level  $L1$  to level  $L2$  is shown in Figure 7 when loading the first level.



**Fig. 6** Creating of root with flight levels

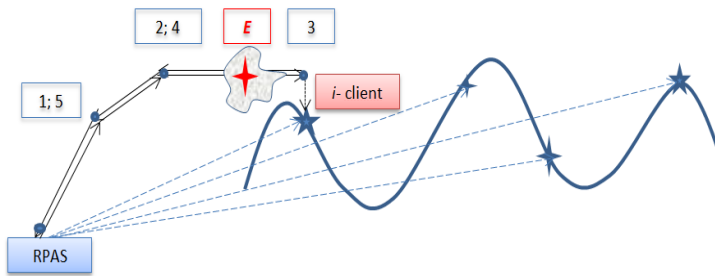
Flow optimization and flexible redistribution of autonomous UAV routes in multi-level airspace is performed in accordance with air navigation rules. The documents of

ICAO include main recommendations for using UAVs, i.e. the operation of the UAV should minimize the threat of harm to life or health of people, damage of property, danger to other aircraft [1; 2; 11].

### 3 What is next?

Further research should be directed to the solution of practical problems of actions UAV's operator in case of emergencies, software creation. The organization of CDM by all aviation operators using collaborative DM models (CDMM) based on general information on the flight process and ground handling of the UAVs. Models of flight emergencies (FE) development and of DM in Risk and uncertainty by UAV's in FE will allow predicting the operator's actions with the aid of the Informational-analytic and Diagnostics complex for research UAV operator's behavior in extreme situation.

For example, the synthesis of models for DM in an emergency if is solving logistic problem UAV flight in bad weather condition (emergency - "loss connection"). (in Figure 7). In the process of analysis and synthesis of DM models of AI in emergency tend to simplify models (stochastic, the neural network, fuzzy, the Markov network, GERT-models, reflexion models to deterministic models).



**Fig. 7** Solving Logistic task using UAVs flights (1 - takeoff and climb, 2 - echelon, 3 - cargo discharge, 4 - echelon reverse, 5 - descent and landing)

In order to simulate DM under conditions of an emergency, next steps: an analysis of an emergency; intelligent data processing; analysis and identification of the situation using stochastic models; decomposition of the situation as a complex situation into subclasses and the formation of adapted deterministic models of AI actions are made. The models for decision and predicting of EF using CDMM – technology presented in Table 2.

In cases of big and difficult data methods can be integrated into traditional and next-generation hybrid DM systems by processing unsupervised situation data in the deep landscape models, potentially at high data rates and in near real time, producing a structured representation of input data with clusters that correspond to common situation types [16]. Deterministic action model targeted to specific situation type. Another benefit of these models is a potential ability of such systems to learn to identify relationships between different types of situations.

**Table 2.** The models for decision in FE using CDMM-technology

Models	Describing of modelling FE
	<p data-bbox="732 504 1246 595">Expert assessment of the complexity of the flight stages (takeoff and climb, echelon, cargo discharge, echelon reverse, descent and landing)</p> <p data-bbox="732 638 1246 779">Neural Network Model to determine potential alternative of the flight completion. Determination of weight coefficients of neural network (probabilities for the model – DM in risk) and effectiveness of flight completion: <math>\{Y_G; Y_{Gacr}; Y_{Glf}; W\}</math>.</p> <p data-bbox="732 801 1246 920">Fuzzy logic to determine quantitative estimates of potential loss - functions of estimation risk <math>R</math> / outcomes <math>U</math> for next models of DM in Risk and Uncertainty-<math>\{g_r\}</math></p> <p data-bbox="732 931 1246 1084">DM in Risk. Stochastic models types' tree, GERT's network (Graphical Evaluation and Review Technique) for DM and FE developing. The optimal solution is found by the criterion of an expected value with the principle of risk - <math>A_{dopt}</math></p> <p data-bbox="732 1113 1246 1223">DM in certainty using Network Planning method and DM in Risk for each branch. Determined models for an operators / AI with deterministic procedure - <math>t_i; T_{cr}; T_{mid}; T_{min}; T_{max}</math></p> <p data-bbox="732 1279 1246 1370">Optimal decision for action in EF (operator / AI model). The authors have developed a computer program for finding optimal solutions [17].</p>

### 4 Conclusion

It was presented a problem of the performance of UAV's flight plans for group flights or single flights for the decision of different target tasks in the city (monitoring, data acquisition, transportations, urban survey, etc.) using information technology, graph theory, and mathematical methods. The configuration and optimization of group flight routes for UAVs depend on the "target task" and results of estimation (cost/safety) territory for UAVs flights. The algorithms of building an ES for estimation of the performance of UAVs flights (group and single) in an urban locality and definition ways of minimal cost/safety of UAVs movement in town were presented. Further research should be directed to the solution of practical problems of actions UAV's operator / AI models in case of emergencies and software creation according

to the target task. Next planned to use new methods for DM (Big Data, Blockchain technology, AI models, next-generation hybrid DM systems; Data mining, etc.).

## References

1. International Civil Aviation Organization (ICAO): Manual on remotely piloted aircraft systems, Doc. 10019/AN 507. 1-ed. Canada, Montreal, (2015).
2. ICAO: Unmanned Aircraft Systems (UAS), Circ. 328-AN/190. Canada, Montreal, (2011).
3. Austin, R., UAS: design, development and deployment, John Wiley & Sons Ltd. USA, (2010).
4. Gulevich, S, Veselov, Y., Pryadkin, S., Tirnov, S.: Analysis of factors affecting the safety of the flight of UAVs. Causes of accidents drones and methods of preventing them. In Journal «Science and education», 2(12), pp.75–94, Russian, (2012).
5. Śładkowski, A., Wojciech, K.: Cases on Modern Computer Systems in Aviation. Chapter 3 Using Unmanned Aerial Vehicles to Solve Some Civil Problems. International Publisher of Progressive Information Science and Technology Research, pp.52-127, USA, Pennsylvania. (2019).
6. Shmelova, T., Bondarev, D.: Graph Theory Applying for Quantitative Estimation of UAV's Group Flight. In Actual Problems of Unmanned Aerial Vehicles Developments (APPUAVD). IEEE 3d International Conference on Proceedings, pp. 328–331. Kyev, (2015).
7. Shmelova, T., Sikirda, Yu., Kovaliov, Yu.: Decision Making by Remotely Piloted Aircraft System's Operator / In APPUAVD. IEEE 4d International Conference in Proceeding. pp. 92-99, Kyev, (2017).
8. LNCS Homepage, <https://dronelife.com/2018/11/28/urban-air-mobility-the-first-uic2-forum-at-amsterdam-drone-week-shows-europes-commitment-to-smart-cities/>, last accessed 2019/05/09.
9. Vyrelkin A., Kucheryavy, A.: The usage of unmanned aircraft solve the tasks of "a smart city" St. Petersburg, Russian (2016)
10. Olifer, V. Olifer, N.: Computer networks: principles, technologies, protocols. St. Petersburg. Russian (2006).
11. ICAO: Manual on Collaborative Decision-Making (CDM). 2nd ed. Doc. 9971. Canada, Montreal, (2014).
12. Kirichek, R., Makolkina M., Sene, J., Takhtuev, V.: Estimation quality parameters of transferring image and voice data over ZigBee in transparent mode. In International Conference on Distributed Computer and Communication Networks pp. 260–267. Russian (2016).
13. Salem, M., Shmelova, T.: Intelligent Expert Decision Support Systems: Methodologies, Applications and Challenges, International Publisher of Progressive Information Science and Technology Research, pp.215-242, USA, Pennsylvania (2018).
14. Shmelova T., Bondarev D.: Unmanned Aerial Vehicles in Civilian Logistics and Supply Chain Management. Chapter 8 Automated System of Controlling Unmanned Aerial Vehicles Group Flight. International Publisher of Progressive Information Science and Technology Research, pp. 208-242. USA, Pennsylvania. (2019).
15. Shmelova, T., Sikirda, Yu.: Applications of Decision Support Systems in Socio-Technical Systems. International Publisher of Progressive Information Science and Technology Research, pp.182-214 USA, Pennsylvania. IRMA (2019).
16. Dolgikh S. Spontaneous Concept Learning with Deep Autoencoder In International Journal of Computational Intelligence Systems, Volume 12, Issue 1, November 2018, pp. 1 – 12, Canada.
17. Shmelova T., Yakunina I., Moiseenko V., Grinchuk M.: Computer program "Network analysis of a special case in flight". Certificate of registration of copyright for the product N55587 (2014)



# Intelligent Method for CSIRT Performance Evaluation in Critical Information Infrastructure

Viktor Gnatyuk<sup>1</sup>, Serhii Smirnov<sup>2</sup>, Marek Aleksander<sup>3</sup>, Liudmila Kharlai<sup>4</sup>,  
Madina Bauyrzhan<sup>5</sup>, Anzhelika Kokareva<sup>6</sup>

<sup>1,6</sup>National Aviation University, Kyiv, Ukraine

<sup>2</sup>Central Ukrainian National Technical University, Kropivnitskiy, Ukraine

<sup>3</sup>State University of Applied Sciences in Nowy Sącz, Nowy Sącz, Poland

<sup>4</sup>Kyiv College of Communication, Kyiv, Ukraine

<sup>5</sup>Satbayev University, Almaty, Kazakhstan

viktorgnatyuk@ukr.net smirnov.ser.81@gmail.com  
aleksandermarek4@gmail.com lharlay@i.ua madina890218@gmail.com  
lika\_nk@ukr.net

**Abstract.** In this paper authors have developed a method for Computer Security Incident Response Team (CSIRT) performance evaluation, which is implemented in the following stages: determining the performance of the CSIRT, defining the Key Performance Indicators (KPI), building a panel of indicators. The developed method can be used to monitor, manage, analyze and enhance the effectiveness of the CSIRT in critical information infrastructure as well as in common (general) information and communication systems. The experimental study of developed method realization for domestic cellular provider was also presented. Given results can be useful for information security audit of company, region or state. Method and the tools based on it will be useful to the leaders of the cyber incident response centers for monitoring, analyzing, assessing and managing the effectiveness of the CSIRT. The developed method can be applied to any company or government agency in order to increase both the level of information security and the efficiency of the work of the employee, department and organization as a whole.

**Keywords:** CSIRT, KPI, Correlation Matrix, Efficiency, Critical Information Infrastructure.

## 1. Introduction

Now, the information security of persons, societies and states is one of the main components of national security in general because information and communication technologies are widely used in all areas.

The problem of information security is not only actual, but also global. Information security incidents become more complex and often [1-4]. Usually, the response to cyber incident directed at CSIRT (Computer Security Incident Response Team) which every year receive more and more assignments and challenges [5]. It becomes

necessary to evaluate and analyze the work of CSIRT [6]. This index is most important to informational security of some organization or country. Periodic (monthly, quarterly, etc.) evaluation of CSIRT's work authorize strong and weak departments, groups, some employees for improving their work in future and highlight some trends based on statistical data. It has special importance in critical information infrastructure for example communication, transportation etc.

The analysis showed that CSIRT performance evaluation not given enough attention, and this could adversely affect the level of information security. After analyzing, the existing methods for evaluating staff or unit discovered that none of the methods is universal. Everyone has advantages and disadvantages. In addition, in order to achieve the maximum result in the evaluation it is possible to use several methods simultaneously. Moreover should take into account the specifics of the organization, staff or unit is estimated. The chosen methods should meet to the structure of the enterprise, the nature of the activities of staff, the objectives of evaluation, to be simple and understandable; include both qualitative and quantitative indicators [7]. Based on this, has developed a method that combines the advantages of known techniques to minimize gaps and takes into account the specifics of the CSIRT.

The developed method consists of three steps: determining the performance of the CSIRT, determining the key performance indicators of the CSIRT, building a panel of indicators and visualizing the dependence of Key Performance Indicators (KPI) and Efficiency (E).

## 2. Theoretical background and experimental study of proposed method

### Stage 1 – Determining the Performance of the CSIRT

When a CSIRT is functioning, the information about Cyber incidents is recorded to the database (DB). Among the basic indicators of the functioning of CSIRT [8, 9], which have quantitative values should be allocated the following (described in following Table 1).

**Table 1.** CSIRT performance indicators

<b>Mark</b>	<b>Name</b>
E	Efficiency
LRI	Level of resolving the incident
INAI	Incorrect number appointments of the incident
DRI	Duration of resolving the incident
ECS	Evaluation customer satisfaction
PRI	The priority of the incident
DIR	Duration of the incident registration
CII	Information provided about the incident

For the implementation of this stage, use a set of performance indicators CSIRT  $PI$

$$PI = \left\{ \bigcup_{q=1}^p PI_q \right\} = \{PI_1, PI_2, \dots, PI_p\} \quad (1)$$

where  $PI_q \subseteq PI, (q = \overline{1, p}), p$ , is the number of performance indicators of the CSIRT. Experimental study will include different input data for Ukrainian cellular provider (as a part of critical information infrastructure of the state, described in papers [5, 14, 16]) for all stages (accumulated statistics for 1st and 2nd quarters of 2018 in accordance – Variant 1 and Variant 2).

Variant 1 (1Q, 2018)

For example, using database with CSIRT metrics for domestic cellular provider during 1st quarter of 2018, let's form Table 2.

**Table 2.** Metrics of CSIRT performance during 1st quarters of 2018

№	E	LRI	INAI	DRI	ECS	PRI	DIR	CII
1	90	4	3	1539	4	3	2	40
2	115	1	0	2502	8	4	6	80
...	...	...	...	...	...	...	...	...
600	171	1	0	37	6	1	6	85

Using (1) and data from Table 1 when  $p = 8$ , we will get:

$$PI_{celprov\_ua2} = \left\{ \bigcup_{q=1}^8 PI_q \right\} = \{PI_1, PI_2, \dots, PI_8\} = \\ \{PI_E, PI_{LRI}, PI_{INAI}, PI_{DRI}, PI_{ESC}, PI_{PRI}, PI_{DIR}, PI_{CII}\} = \\ \{E, LRI, INAI, DRI, ESC, PRI, DIR, CII\}$$

where  $PI_1 = PI_E = E, PI_2 = PI_{LRI} = LRI, \dots, PI_8 = PI_{CII} = CII$  are metrics of CSIRT activity (performance).

Output data of this stage consist of metrics of CSIRT performance described in mentioned Table 2.

Variant 2 (2Q, 2018)

For example, using database with CSIRT metrics for domestic cellular provider during 2nd quarter of 2018, let's form Table 3.

**Table 3.** Metrics of CSIRT performance during 2nd quarters of 2018

№	E	LRI	INAI	DRI	ECS	PRI	DIR	CII
1	109	1	0	55	5	1	5	70
2	86	4	2	560	4	2	4	60
...	...	...	...	...	...	...	...	...
600	150	1	0	40	8	1	4	60

Using (1) and data from Table 1 when  $p = 8$ , we will get:

$$PI_{celprov\_ua3} = \left\{ \bigcup_{q=1}^8 PI_q \right\} = \{PI_1, PI_2, \dots, PI_8\} = \\ \{PI_E, PI_{LRI}, PI_{INAI}, PI_{DRI}, PI_{ESC}, PI_{PRI}, PI_{DIR}, PI_{CII}\} = \\ \{E, LRI, INAI, DRI, ESC, PRI, DIR, CII\}$$

where  $PI_1 = PI_E = E, PI_2 = PI_{LRI} = LRI, \dots, PI_8 = PI_{CII} = CII$  metrics of CSIRT performance.

In a similar way to variant 1 output data of this stage consist of metrics of CSIRT performance described in mentioned Table 3.

### Stage 2 – Determination of Key Performance Indicators for CSIRT

To determine the Key Performance Indicators from the set of CSIRT performance indicators was used the multiple correlation-regression analysis process [10], which includes the following steps:

*Step 1. Selection of all possible factors*, which affect on the indicator (or process) that being investigated. Each factor determines numerical characteristics if some factors can't be quantitatively or qualitatively determined or statistics are not available to them, they will be removed from further consideration.

*Step 2. Choosing a regressive or multi-factor model*, that is finding an analytical expression that describes the link between factors with the resultant (function selection):

$$\hat{Y} = f(x_1, x_2, x_3, \dots, x_d) \quad (2)$$

where  $\hat{Y}$  is resultant variable function;  $x_1, x_2, x_3, \dots, x_d$  are factors signs.

An important problem is the choice of an analytical form for a function that links factors with a resultant feature-function. This function has to show real connections between the studied parameters and factors. It is important to note that the empirical justification of the type of function using the graphic analysis of the connections for multi-tasking models is unsuitable. Given that, any function of many variables by logarithms or replacement of variables can be reduced to a linear form then in practice the multiple regression equations are given linearly:

$$\hat{Y} = (a_0 x_0 + a_1 x_1 + a_2 x_2 + \dots a_d x_d) \quad (3)$$

where  $a_0, a_1, a_2 \dots a_d$  are parameters of the equation must to be measured.

If for every factor and for a productive feature known  $d$  values  $y_h, x_{1h}, x_{2h}, \dots, x_{dh}$  at  $h = 1, 2, \dots, m$  then using the standard procedure of the least squares method to evaluate the parameters a system of linear algebraic equations will be obtained.

$$\left\{ \begin{array}{l} a_0 m + a_1 \sum_{j=1}^m x_{1j} + a_2 \sum_{j=1}^m x_{2j} + \dots a_d \sum_{j=1}^m x_{dj} = \sum_{j=1}^m y_j \\ a_0 \sum_{j=1}^m x_{1j} + a_1 \sum_{j=1}^m x_{1j}^2 + a_2 \sum_{j=1}^m x_{1j} x_{2j} + \dots a_d \sum_{j=1}^m x_{1j} x_{dj} = \sum_{j=1}^m x_{1j} y_j \\ a_0 \sum_{j=1}^m x_{dj} + a_1 \sum_{j=1}^m x_{dj} x_{1j} + a_2 \sum_{j=1}^m x_{dj} x_{2j} + \dots a_d \sum_{j=1}^m x_{dj}^2 = \sum_{j=1}^m x_{dj} y_j \end{array} \right. \quad (4)$$

The

obtained system  $d + 1$  of equations with  $d + 1$  unknowns  $a_0, a_1, \dots, a_d$  can be solved by methods of linear algebra. For many equations would be best to use the

method of choice Gauss main element. Since the matrix of the system of linear equations is symmetric, it is always a solution, and the only one. If the number of equations is small, then can be successfully used the inverse matrix method to solve the problem.

*Step 3. Activity checking of received model.* To do this need to calculate:

– Remnants of the model as the differences between the observed and estimated values:

$$u_h = y_h - \widehat{y}_h = y_h - (a_0 + a_1x_{1h} + a_2x_{2h} + \dots + a_dx_{dh}), h = 1, 2, \dots, m \quad (5)$$

– Relative error of the residues and its average value:

$$\delta_h = \frac{u_h}{y_h} \cdot 100\%, \quad \delta = \frac{\sum_{h=1}^m \delta_h}{m} \quad (6)$$

– RMS error variance disturbances:

$$\delta_u = \sqrt{\frac{\sum_{h=1}^m u_h^2}{m-d-1}} \quad (7)$$

– Determination factor:

$$R^2 = 1 - \frac{\sum_{h=1}^m u_h^2}{\sum_{h=1}^m (y_h - \bar{y})^2} \text{ or } R^2 = 1 - \frac{\sum_{h=1}^m (y_h - \bar{y})^2}{\sum_{h=1}^m (y_h - \bar{y})^2} \quad (8)$$

– Coefficient of multiple correlation, which is the main indicator of the correlation density of a generalized indicator with factors:

$$R = \sqrt{1 - \frac{\sum_{h=1}^m (y_h - \bar{y})^2}{\sum_{h=1}^m (y_h - \bar{y})^2}} \quad (9)$$

All values of the coefficient of correlation R belong to the interval from -1 to 1. The sign of the coefficient shows the «direction» of the connection: the positive value indicates a "direct" connection, the negative value – about the «reverse» connection, and the value «0» – the absence of linear correlation communication. With  $R = 1$  or  $R = -1$  system has functional link between the signs. The multiplicity of the correlation coefficient is the main characteristic of the tightness of the link between the resultant sign and the combination of factors.

Step 4. Checking the statistical significance of the results. Testing is carried out using Fisher statistics with  $d$  and  $(m-d-1)$  degrees of freedom:

$$F = \frac{\sum_{h=1}^m (\hat{y}_h - \bar{y})^2}{d} \text{ or } F = \frac{R^2}{1-R^2} \cdot \frac{m-d-1}{d} \quad (10)$$

where  $d$  is the number of factors included in the model;  $m$  is total number;  $\hat{y}_h$  is estimated value of the dependent variable at  $h$ -th observation;  $\bar{y}$  is the average value of the dependent variable;  $y_h$  is the value of the dependent variable at  $h$ -th observation;  $R$  is coefficient of multiple correlation.

According to Fisher's tables critical value  $F_{\kappa p}$  at  $d$  and  $(m-d-1)$  degrees of freedom. If  $F > F_{\kappa p}$ , it means about adequacy of the constructed model. If the model is not adequate then it is necessary to return to the stage of constructing the model and possibly introduce additional factors or switch to a nonlinear model.

Step 5. Check significance of regression coefficients. Testing is carried out using t-statistics that parameters for multivariate regression is:

$$t_h = \frac{a_h}{\delta_{ah}^2} \quad (11)$$

where  $\delta_{ah}$  is standard deviation assessment of  $h$  parameter.

If the value of  $t_h$  exceeds the critical value, which is based on the tables of the  $t$ -criterion of the Student, then the corresponding parameter is statistically significant and has a significant impact on the aggregate indicator.

Step 6. Calculation the elasticity factor. Differences in the units of measurement of factors are eliminated by using partial elasticity factors, which are given by the ratio:

$$\varepsilon_h = \frac{d\bar{y}}{dx_h} \cdot \frac{\bar{x}_h}{\bar{y}} \quad (12)$$

where  $x_h$  is average value of  $h$ -th parameter;  $\bar{y}$  is the average value of effective signs.

Partial elasticity coefficient indicates the percentage change in average productive sign of a change of 1% factor for fixed values of other parameters.

Step 7. Determination of confidence intervals for regression parameters. Confidence interval at reliability level  $(1-\alpha)$  is an interval with randomly defined limits with confidence level  $(1-\alpha)$  Overstate the true value of the coefficient of the regression equation  $a_h$  and has the following form:

$$a_h - t_{a/2,z} \sigma_{ah}^2; a_h + t_{a/2,z} \sigma_{ah}^2 \quad (13)$$

where  $t_{\alpha/2,z}$  is Student's statistics with  $z = m - d - 1$  degrees of freedom and levels of significance  $\alpha$ ;  $\sigma_{ah}^2$  is average square deviation of estimation parameter  $a_h$ .

Suppose system has  $s$  random variables  $x_1, x_2, \dots, x_{rz}, \dots, x_{rv}$  (investigated parameters) represented by samples by  $v$  values  $\mathbf{x}_r = \{x_{r1}, x_{r2}, \dots, x_{rz}, \dots, x_{rv}\}$ . For each pair of random variables  $x_r$  and  $x_w$  the equation can estimate the value of the empirical coefficient of linear correlation  $r_{rw}$ . The obtained coefficients are written into the matrix size  $S \times S$ :

$$\begin{pmatrix} 1 & k_{12} \dots & r_{1w} \dots & k_{1s} \\ r_{21} & 1 & \dots & r_{2w} \dots & r_{2s} \\ r_{r1} & r_{r2} \dots & 1 & \dots & r_{rs} \\ r_{s1} & r_{s2} \dots & r_{sw} \dots & 1 \end{pmatrix}. \quad (14)$$

All correlation coefficient  $r$  belong to the interval from -1 to 1. The sign of the coefficient shows the «direction» of the connection: the positive value indicates a «direct» connection, the negative value – about the «reverse» connection, and the value «0» – the absence of linear correlation communication. With  $R = 1$  or  $R = -1$  system has functional link between the signs. The multiplicity of the correlation coefficient is the main characteristic of the tightness of the link between the resultant sign and the combination of factors. [11].

Using the above calculation procedure of multiple regression analysis it is possible to evaluate the degree of influence on the researched result indicator  $PI_1$  each of the factors introduced into the model  $PI_2, PI_3, \dots, PI_p$  and identify a set of KPI:

$$KPI = \left\{ \bigcup_{aw=1}^{av} KPI_{aw} \right\} = \{KPI_1, KPI_2, \dots, KPI_{av}\} \quad (15)$$

where  $KPI_{aw} \subseteq KPI, (aw = 1, av)$  is number of KPI.

Variant 1 (1Q, 2018)

Input data for current stage consist of matrix with CSIRT performance metrics (Table 2). Next by using multiple correlation-regression analysis we will get correlation matrix (Table 4).

**Table 4.** Correlation matrix for 1st quarters of 2018

E	1							
LRI	-0,37	1						
INAI	-0,79	0,35	1					
DRI	-0,49	0,36	0,66	1				
ECS	0,82	-0,47	-0,57	-0,51	1			
PRI	-0,91	0,57	0,47	0,67	-0,63	1		
DIR	0,19	-0,52	-0,52	-0,63	0,43	-0,60	1	
CII	0,89	-0,62	-0,52	-0,45	0,72	-0,58	0,29	1
	E	LRI	INAI	DRI	ECS	PRI	DIR	CII

Analyzing mentioned Table 4 and using Chaddock's scale we can declare about the most influence factors: The priority of the incident (PRI); Incorrect number appointments of the incident (INAI); Evaluation customer satisfaction (ECS); Information provided about the incident (CII).

Output data of this stage in accordance to (2) and when  $w = 4$  is the following set of Key Performance Indicators  $KPI$  :

$$KPI_{CSIRT1Q} = \left\{ \bigcup_{w=1}^4 KPI_w \right\} = \{KPI_1, KPI_2, KPI_3, KPI_4\} = \\ \{KPI_{PRI}, KPI_{INAI}, KPI_{ESC}, KPI_{CII}\} = \{PRI, INAI, ESC, CII\},$$

where

$$KPI_1 = KPI_{PRI} = PRI, KPI_2 = KPI_{INAI} = INAI, KPI_3 = KPI_{ESC} = ESC, \\ KPI_4 = KPI_{CII} = CII$$

are Key Performance Indicators: the priority of the incident, incorrect number appointments of the incident, evaluation customer satisfaction, information provided about the incident consequently.

VARIANT 2 (2Q, 2018)

Input data for current stage consist of matrix with CSIRT performance metrics (Table 3). Next by using multiple correlation-regression analysis we will get correlation matrix (Table 5).

Analyzing mentioned Table 5 and using Chaddock's scale we can declare about the most influence factors: The priority of the incident (PRI); Incorrect number appointments of the incident (INAI); Information provided about the incident (CII).

**Table 5.** Correlation matrix for 2nd quarters of 2018

E	1							
LRI	-0,35	1						
INAI	-0,83	0,43	1					
DRI	-0,43	0,38	0,62	1				
ECS	0,64	-0,57	-0,52	-0,41	1			
PRI	-0,89	0,53	0,43	0,57	-0,53	1		
DIR	0,23	-0,47	-0,56	-0,53	0,53	-0,45	1	
CII	0,81	-0,54	-0,55	-0,55	0,62	-0,39	0,34	1
	E	LRI	INAI	DRI	ECS	PRI	DIR	CII

In similar manner to variant 1 output data of this stage in accordance to (2) and when  $w = 3$  is the following set of Key Performance Indicators  $KPI$  :

$$KPI_{CSIRT2Q} = \left\{ \bigcup_{w=1}^3 KPI_w \right\} = \{KPI_1, KPI_2, KPI_3\} = \\ \{KPI_{PRI}, KPI_{INAI}, KPI_{CII}\} = \{PRI, INAI, CII\},$$



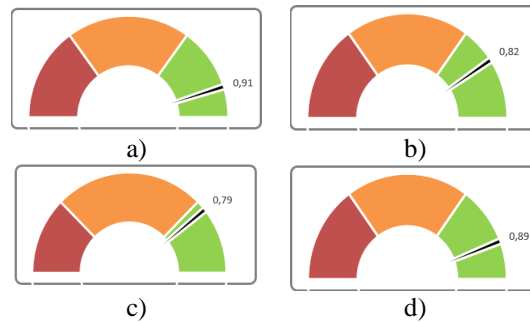
where  $KPI_1 = KPI_{PRI} = PRI$ ,  $KPI_2 = KPI_{INAI} = INAI$ ,  $KPI_3 = KPI_{CII} = CII$  are Key Performance Indicators: the priority of the incident, incorrect number appointments of the incident, information provided about the incident consequently.

**Stage 3 – Indicators Panel and Visualization for KPI and E Dependencies**

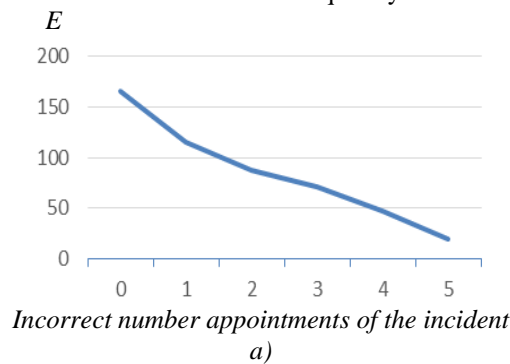
Proposed method is constricting the indicators panel [15], which will help with monitoring and CSIRT performance management. The indicators panel is tool for visualization and information analysis about business processes and their effectiveness. The data displayed on the panel indicators usually looks in the KPI form. Panel indicator system may be part of a corporate information system or act as a standalone application [12,15]. Using the indicator panel will present the data in a convenient form – diagrams, charts and data charts. For each organization, depending on its operational, planning and strategic tasks, this panel is made individually [13].

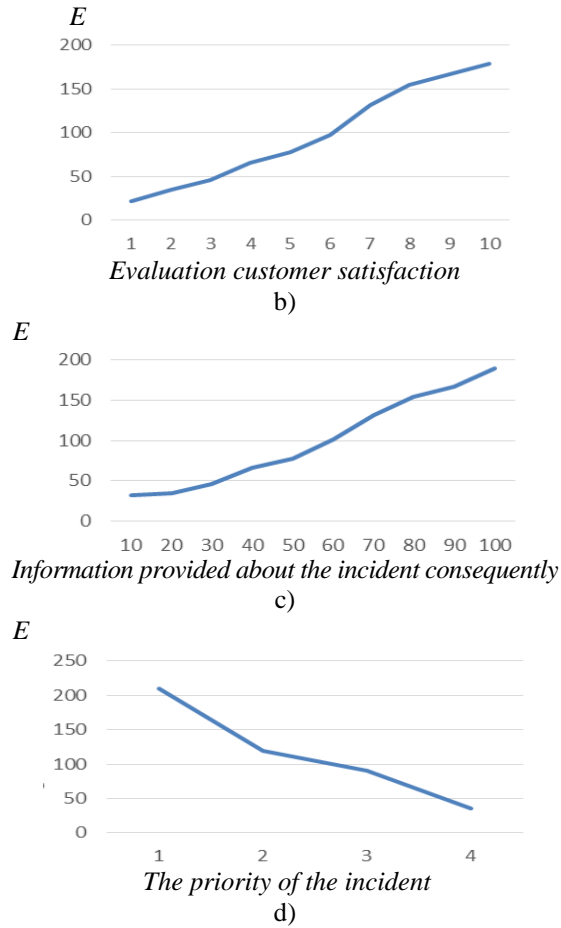
Variant 1 (1Q, 2018)

Using output data from 2nd stage we can visualize given results, presented in Fig. 1-2:



**Fig. 1.** Correlation coefficients values: a) the priority of the incident; b) evaluation customer satisfaction; c) incorrect number appointments of the incident; d) information provided about the incident consequently.



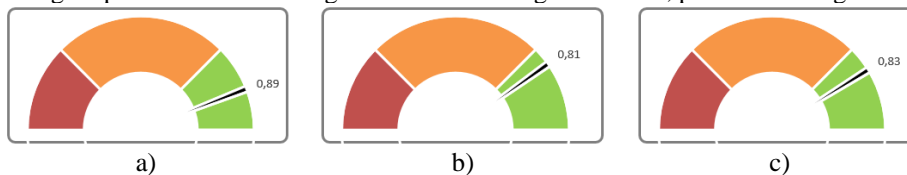


**Fig. 2.** Efficiency dependency on: a) incorrect number appointments of the incident; b) evaluation customer satisfaction; c) information provided about the incident consequently; d) the priority of the incident

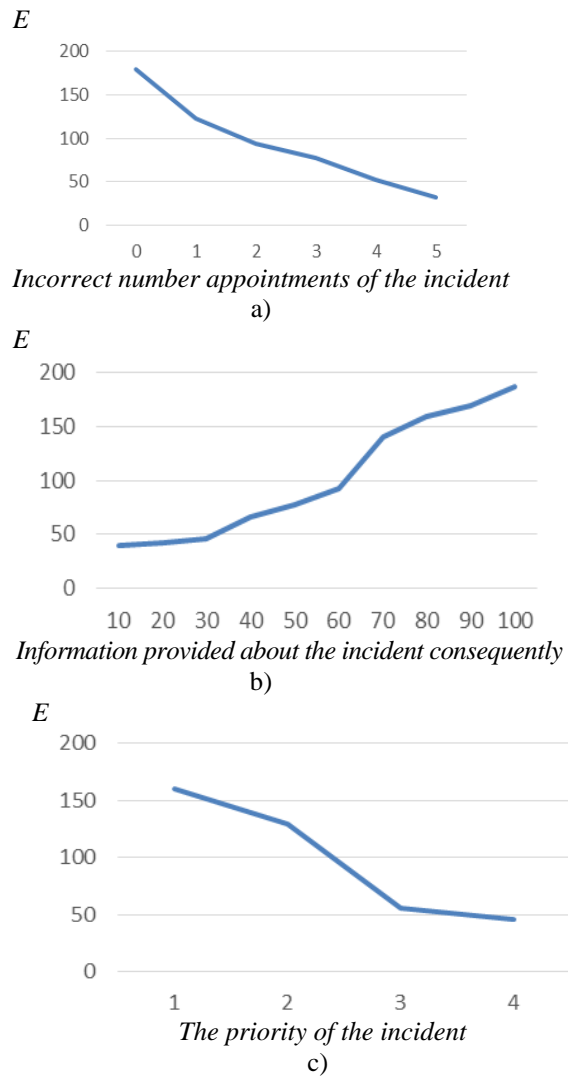
Analysis of given results presented on Figs. 1-2 gives a possibility to define dependency between  $E$  and all of defined KPI and also form limitations: if INAI > 1, then  $E < 100$ ; if ECS < 7, then  $E < 100$ ; if CII < 60, then  $E < 100$ ; if PRI < 2, then  $E < 100$ .

Variant 2 (2Q, 2018)

Using output data from 2nd stage we can visualize given results, presented in Fig. 3-4:



**Fig 3.** Correlation coefficients values: a) the priority of the incident; b) information provided about the incident consequently; c) incorrect number appointments of the incident.



**Fig. 4.** Efficiency dependency on: a) Incorrect number appointments of the incident; b) Information provided about the incident consequently; c) The priority of the incident

Analysis of given results presented on Fig. 3-4 gives a possibility to define dependency between E and all of defined KPI and also form limitations: if INAI > 1, then E < 100; if CII < 70, then E < 100; if PRI < 2, then E < 100.

### 3. Conclusions

As can be seen from the theoretical background and experimental study, proposed method for assessing the effectiveness of the CSIRT can be used for determining the performance of the CSIRT. It allows the allocation of Key Performance Indicators among of them, using a multi-factor correlation-regression analysis in construction of indicators panel and visualization of KPI and Efficiency dependencies gives an opportunity to audit the CSIRT activities (performance) and other centers of information and telecommunication systems maintenance (particularly in critical information infrastructure). This method and the tools based on it will be useful to the incident response centers managers for monitoring, analyzing, assessing and managing the effectiveness of the CSIRT. Since the method is universal and can be applied to any company or government agency, in order to increase both the level of information security and the efficiency of the employee, department and organization.

### References

1. Z. Hu, S. Gnatyuk, O. Koval, V. Gnatyuk, S. Bondarovets, Anomaly Detection System in Secure Cloud Computing Environment, *International Journal of Computer Network and Information Security*, Vol. 9, № 4, pp. 10-21, 2017.
2. M. Aleksander, L. Dubchak, V. Chyzh, A. Naglik et al, Implementation technology software-defined networking in Wireless Sensor Networks, *Proceedings of 2015 IEEE 8th International Conference on Intelligent Data Acquisition and Advanced Computing Systems: Technology and Applications*, Warsaw, Poland, September 24-26, 2015.
3. Ya. Wahba, E. El Salamouny, Gh. El Taweel, Estimating the Sample Size for Training Intrusion Detection Systems, *International Journal of Computer Network and Information Security (IJCNIS)*, vol.9, No.12, pp.1-10, 2017.
4. Security of Critical Information Infrastructures, Tobias Dehling, Sebastian Lins, Ali Sunyaev, *Information Technology for Peace and Security*, pp. 319-339.
5. S. Gnatyuk, Critical Aviation Information Systems Cybersecurity, Meeting Security Challenges Through Data Analytics and Decision Support, *NATO Science for Peace and Security Series, D: Information and Communication Security*, IOS Press Ebooks, Vol.47, №3, pp. 308-316, 2016.
6. A. Gizun, V. Gnatyuk, N. Balyk, P. Falat, Approaches to Improve the Activity of Computer Incident Response Teams, *Proceedings of the 2015 IEEE 8th International Conference on «Intelligent Data Acquisition and Advanced Computing Systems: Technology and Applications» (IDAACS'2015)*, Warsaw, Poland, September 24-26, 2015: vol. 1, pp. 442-447, 2015.
7. A. Tikhomirov, N. Kinash, S. Gnatyuk, A. Trufanov, O. Berestneva et al, Network Society: Aggregate Topological Models, *Communications in Computer and Information Science*. Verlag: Springer International Publ, vol. 487, pp. 415-421, 2014.
8. Jan Van Bon, *IT Service Management*, 240 p., 2003.
9. V. Kinzeryavyy, V. Gnatyuk, Basic performance parameters for cyberincidents response teams, *Ukrainian Scientific Journal of Information Security*, № 20, №2, p. 193-196, 2014. DOI: 10.18372/2225-5036.20.7307
10. A. Marmoza, *Theory of statistic*, Kyiv, pp. 333-397. 2013.
11. Yu. Danik, R. Hryshuk, S. Gnatyuk, Synergistic effects of information and cybernetic interaction in civil aviation, *Aviation*, vol. 20, №3, pp. 137-144, 2016.
12. Wayne W. Eckerson, *Performance Dashboards*, Moscow, Alpyna Business Books, 396 p., 2007.

13. Z. Hu, Yu. Khokhlachova, V. Sydorenko, I. Opirskyy, Method for Optimization of Information Security Systems Behavior under Conditions of Influences, *International Journal of Intelligent Systems and Applications (IJISA)*, vol.9, № 12, 2017, pp.46-58.

14. S. Gnatyuk, V. Sydorenko, M. Aleksander, Unified data model for defining state critical information infrastructure in civil aviation, *Proceedings of the 2018 IEEE 9th International Conference on Dependable Systems, Services and Technologies (DESSERT)*, Kyiv, Ukraine, May 24-27, 2018, pp. 37-42.

15. R. Odarchenko, V. Gnatyuk, S. Gnatyuk, A. Abakumova, Security Key Indicators Assessment for Modern Cellular Networks Kyiv, *Proceedings of the 2018 IEEE First International Conference on System Analysis & Intelligent Computing (SAIC)*, Ukraine, October 8-12, 2018, pp. 1-7.

16. Yu. Danik, R. Hryshchuk, S. Gnatyuk, Synergistic effects of information and cybernetic interaction in civil aviation, *Aviation*, vol. 20, №3, 2016, pp. 137-144.

# Polynomials Multiplier under Irreducible Polynomial Module for High-Performance Cryptographic Hardware Tools

Maksat Kalimoldayev<sup>1</sup>, Sakhybay Tynymbaev<sup>2</sup>, Miras Magzom<sup>2</sup>, Margulan Ibrahimov<sup>2</sup>, Serik Khokhlov<sup>2</sup>, Akmaral Abisheva<sup>2</sup>, Viktoriia Sydorenko<sup>3</sup>

<sup>1</sup>Information and Computational Technologies Institute, Almaty, 050010, Kazakhstan

<sup>2</sup>Al-Farabi Kazakh National University, Almaty, 050040, Kazakhstan

<sup>3</sup>National Aviation University, Kyiv, 03058, Ukraine

s.tynym@mail.ru margulan.ibraimov@kaznu.kz  
magzom\_miras@gmail.com ak\_maral@mail.ru v.sydorenko@ukr.net

**Abstract.** One of the most popular and effective methods of information security is cryptographic, that can be realized in software as well as in hardware tools. Hardware cryptographic devices are oriented on confidentiality ensuring put some actual problems must be solved. For the purpose to raise the performance of computing devices productivity, it is necessary to use number systems without the disadvantages of the radix numeration system. This is due to the fact that while performing on multi-digit numbers arithmetic operations represented in the positional system, it becomes necessary to take into account inter-bit transfers that far slows down the computation speed and complicates the calculator structure. The new ways search to improve the computing devices performance led researchers to an objective conclusion that in this direction of the positional number system all possibilities have been exhausted. In order to boost productivity of computing devices, it is necessary to use number systems without such disadvantages.

**Keywords:** Information Security, Cryptosystem, FPGA, Polynomials, Modular Multiplication.

## 1. Introduction

Topical tendencies of computer equipment and system development require the elaboration of high-performance computing devices, including information security. By information and communication networks and the integrating devices development the need for creating efficient cryptographic transformations hardware solutions will grow. For example, hardware cryptographic devices are few times faster than software cryptographic tools. But hardware tools have some problems that must be solved to provide efficient confidentiality ensuring.

## 2. Modern Approaches and Problem Definition

There are tasks leading to calculations when the integer values variables far exceed the maximum range of typical computing devices, defined by the hardware-supported machine word length [1, 2]. The hardware implementation deemed to be efficient from the point of view of processing speed and capabilities, solving such issues by traditional approaches is near impossible [3, 4].

For example, concerning ECC or RSA cryptosystems, the main difficulty in cryptographic transformations is first of all due to the need to perform sequential modular multiplication by multi-digit numbers [5]. In such cryptosystem implementation, an important task is to ensure effective modular multiplication [6].

It should not be overlooked, that most of the modern computing equipment operates in a radix numeration system. For multi-digit numbers arithmetic operations represented in the traditional positional system, a need to take into account inter-bit transfers arises, that significantly slows down the computation speed and complicates the calculator structure.

Consequently, relevant researches devoted for searching new ways to improve the computing devices performance are topical. The studies focused on the use of non-traditional methods of coding numerical information and the corresponding parallel variants of computer arithmetic are of great importance.

The value of each numeric character (number) in the designation of a number depends on its position or digit in the traditional radix numeration system. However, besides this, there are also so-called “non - radix numeration system”, one of which is the “residue number system” (RNS) [7]. RNS application is an efficient way of large data calculations. Particularly, the RNS application allows to increase the operations speed due to the lack of transfer when adding, dividing a large block of input data into smaller sub-blocks and parallel processing.

The residue number system is a data representation system in computational arithmetic, where integer is denoted by a set of smaller numbers.

In the residue number system, a positive integer is represented as a sequence of residues or deductions:

$$A = (a_1, a_2, \dots, a_n). \quad (1)$$

From dividing to set positive integers  $p_1, p_2, \dots, p_n$ , that are called as system basis.

$\alpha_i$  numbers are derived in such a way:

$$\alpha_i = A - \left[ \frac{A}{p_i} \right] p_i, \quad i = \overline{1, n}, \quad (2)$$

where  $[A/p_i]$  means whole part from dividing  $A$  by  $p_i$ . From (2) it follows, that number  $i$ -bit  $\alpha_i$  of number  $A$  is the least positive remainder of the dividing  $A$  by  $p_i$  and  $\alpha_i < p_i$ . In this case, the digits formation of each bit is carried out independently of each other. In accordance with the Chinese theorem on remainder number representation  $A$  in the form (1) will be unique if the numbers are  $p_i$  pairwise simple.

The range volume of representable numbers in this case is equals to  $P = p_1, p_2, \dots, p_n$ .

In this case, similarly to the radix numeration system, the range of representable

numbers grows as a product of bases, and the digit bits of numbers grows as the sum of the digit capacity of the same bases.

The main privileges that make it possible to effectively use modular arithmetic in some fields of computing technology are: a high level of natural parallelism at the number system level, that is related to the absence of digits transfer in addition and multiplication, as well as the absence of error propagation. In contrast to the radix numeration system, all vector elements are equivalent, and an error in one of them leads only to a dynamic range reduction. This fact allows you to design devices of high fall-over protection and error correction [8].

These features ensure good advantages for RNS over the radix number system at modular operations of addition, subtraction and multiplication. This is especially true if multi-digit numbers act as operands.

Strategic pathway in RNS application in computing is the development of cryptographic information security tools. The research team headed by R.G. Biyashev proposed modular encryption and digital signature generation algorithms based on the nonpositional polynomial number system (NPNS) [9-11]. The purpose of research is the development, research and implementation of information security cryptographic algorithms, developed on the basis of non-positional polynomial number systems, in information and communication systems and networks for various purposes. The block symmetric encryption algorithms developed by them are built on the basis of this approach and are the research results analyzing the possibility of using the non-positional encryption algorithm in practice [12]. Also in this direction there are important works devoted to parallel computation [13-14] as well as papers [15-16].

Taking into account the above stated, the development of computation hardware for the NPNS is an urgent task, the solution of which will provide opportunities for creating efficient cryptosystems hardware implementations based on polynomial RNS.

### **3. Results and Discussion**

Nowadays, the residual numbers system (RNS) is often applied for the development of efficient and high-performance special-purpose processes. RNS is widely applied in cryptography. For example, modular arithmetic allows to create an effective cryptographic systems hardware implementation. The non-positional number systems application allows us to accelerate slow computations in asymmetric encryption algorithms and increase reliability.

The developed non-positional encryption systems, as a cryptographic strength criterion, applies not the key length, but the cryptographic strength of the cryptoalgorithms themselves. The use of non-positional polynomial number systems (NPNS) also makes possible to increase the algorithms efficiency, as in accordance with NPNS rules, all arithmetic operations can be performed in parallel using the modules of the NPNS bases.

For the implementation of the developed algorithms in the form of modules combined into a cryptographic security system (CSS) works on program efficiency are carried out. As well as, work is being carried out to build software and hardware and hardware implementations of cryptographic information security symmetric algorithms based on the NPNS.



As hardware-software and hardware implementation has the best speed characteristics, the cryptographic algorithm integrity is guaranteed and allows to optimize many of the mathematical operations adopted in encryption algorithms. For developed algorithms software and hardware implementation, parts of the procedures are implemented in hardware.

The basic device for non-positional polynomial number systems is a device for multiplying polynomials modulo an irreducible polynomial, where data encryption and decryption routine calculations are performed.

In this research, we consider an approach to polynomials multiplying  $A(x)$  and  $B(x)$  modulo an irreducible polynomial  $P(x)$ , that is,  $[A(x)*B(x)]\text{mod}P(x)$ , where  $\text{deg}A(x), \text{deg}B(x) < \text{deg}P(x)$ .

In each multiplication process step, the partial remainder  $r_i$  is calculated by the former partial remainder shaper by adding modulo two double the previous partial remainder  $2r_{i-1}$ , with the result of the logical multiplication of the polynomial  $A(x)$  (multiplicand) by the next high bit of the polynomial  $B(x)$  – multiplier modulo irreducible polynomial  $P(x)$ .

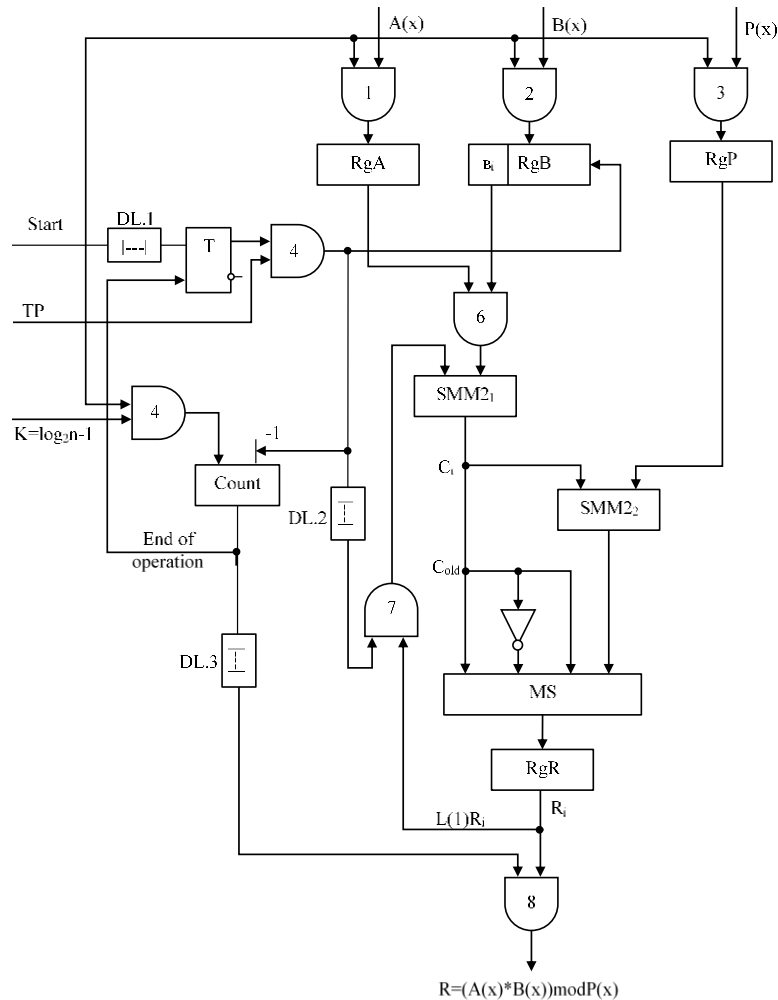
Then the  $i$ -th partial remainder is determined by the formula:  $r_i = (2r_{i-1} \oplus A(x)*b_i)\text{mod}P(x)$ , where  $b_i$  is the  $i$ -th high bit of the binary image of the polynomial  $B(x)$ , ( $b_i = \{0,1\}$ ).  $A$  is the binary image of the polynomial  $A(x)$ .  $P$  is binary image of the irreducible polynomial  $P(x)$ .

The considered multiplier functional diagram is shown in Fig.1.

The device includes  $RgA$  for binary image storing of the polynomial  $A(x)$  (multiplicative), shifting the  $RgB$  register for the binary image of the polynomial storing  $B(x)$  (multiplier), the  $RgR$  register for storing the binary image of an irreducible polynomial (module), adder AD1, where modulo 2 sum up the doubled previous remainder  $2r_{i-1}$  with the multiplicand  $A(x)$  with  $b_{i-1}=1$ , forming  $C_i = 2r_{i-1} + b_{i-1} * A(x)$ . Modulo-two adder (AD2), together with a multiplexer (MS), modifies  $C_i$  modulo  $P(x)$ . Register  $RgR$  serves to store intermediate remainders.

Additionally, the multiplier contains a subtracting timing pulse (COUNT), where, at the end of the operation, the “End of Operation” signal is generated. T Trigger, that allow the passage of timing pulses into the circuit.

We consider the multiplier operation. By “START” signal, the binary  $A(x)$ ,  $B(x)$  and  $P(x)$  polynomials coefficients are received by the blocks of the I1, I2, I3 diagrams, respectively, in the registers  $RgA(x)$  and  $RgB(x)$ ,  $RgP(x)$ . Besides this, by “START” signal, the binary code (k) of the multiplier digits number is received in the TP count. The “Start” signal prior to reaching at the single trigger input T is delayed on the DL.1 delay line. The delay on LZ.1 is determined by the total delay time on  $RgA(x)$ , I6, AD1, AD2, MS and the recording time of the remainder in the  $RgR$  register and the delay time is shifted by  $Shf(L1)$ .



**Fig. 1** Functional multiplier diagram of polynomials irreducible polynomials modulo

Upon the “Start” signal is reached the trigger input T and translates it into a single state, that allows the first timing pulse TP1 to pass from the output of the I4 diagram. At this point in the RgR register, the partial remainder is  $r_0 = C_0$ , with  $r_{i-1} = 1$ , since  $egA(x) < deg P(x)$ .

The first timing signal RgB(x) is shifted to the left by one digit, while in the high order RgB(x) the value of the next coefficient of the polynomial  $B(x) - b_{i-2}$  is fixed, provided to the control inputs of the I6 diagrams, and to the other inputs of the polynomial A(x) values coefficients. If, at the same time,  $b_{i-2} = 1$ , then the polynomial coefficients are provided to the right-hand inputs of the AD1 adder. TSI at the time of the RgB(x) shift is delayed by the delay line DL.2 and is provided to the

control inputs of diagram I7, and the information inputs are supplied by the remainder from the outputs of the Shf diagrams(L1) (L1)  $2r_{i-1}$ .

From I7 output, the doubled remainder is provided to the left inputs of the AD1 adder. When  $b_{i-2} = 1$ , the output of this adder is  $C_1 2r_{i-1} \oplus A(x)$ .

If  $b_{i-2} = 0$ ,  $C_1 = 2r_0$ . Next, the  $C_1$  value is provided to the left inputs of the adder modulo 2 (AD2). Moreover, if  $C_1 < P(x)$ , then the multiplexer (MS) outputs the value  $C_1$  and is written to the  $RgR$  register forming the value  $r_1$ .

If  $C_1 \geq P(x)$ , then the MS multiplexer outputs the result  $C_1 \oplus P(x)$ , shaping also the value  $r_1$ . Further, the remainder  $r_1$  is shifted one digit to the left by the Shf shifter (L1).

At this point, the I4 diagram output of the receives the TP2 timing pulse shifting the contents of the  $RgB(x)$  register. AD 1,  $RgA(x)$  inputs are provided depending on the value of  $b_{i-3}$ , and the second inputs are provided with the bits of the residual  $r_1$  multiplied by two. AD1 output, the  $C_2$  value is formed and with the help of the adder AD2 and the multiplexer MS,  $C_2$  is modulo, shaping the remainder  $r_2$ .

It is noteworthy that when each timing pulse reaches, a unit is subtracted from the TP count. Upon  $n-1$  timing signal reaches the  $RgR$  register, the result of multiplying the polynomials modulo the irreducible polynomial is generated and the TPC is set to "0" and the counter generates a "end of operation" signal that sets the trigger T to the zero position, preventing the next timing signal from passing output diagram I4. At the time of last remainder shaping signal "end of operation" are delayed on the delay line DL.3. After that, the result is given to the outputs by the diagram I8.

If to consider an example of multiplying polynomials modulo an irreducible polynomial in the multiplier diagram shown in Figure 1.

Let  $A(x) = x^4 + x + 1$ ,  $B(x) = x^4 + x^2 + 1$ ,  $P(x) = x^5 + x^2 + 1$ .

Binary representations of polynomials are presented below (see Table 1):  $A = 100112$ ;  $B = 10,012$ ;  $P = 1001012$ .

**Table 1.** Example of multiplying

№	$RgR$ bits	AD1	AD2
1	2	3	4
Start	$b_4 = 1$	$  \begin{array}{r}  A = 010011 \\  \oplus \\  000000 \\  A = 010011  \end{array}  $	$  \begin{array}{r}  C_0 = 010011 \\  \oplus \\  P(x) 100101 \\  \hline  r_1 = 010011  \end{array}  $
TP1	$b_3 = 0$	$C_1 = 2r_1 = 100110$	$  \begin{array}{r}  C_1 = 100110 \\  \oplus \\  P(x) 100101 \\  \hline  r_2 = 000011  \end{array}  $

TP 2	$b_2 = 1$	$C_2 = 2r_2 + A =$ $\begin{array}{r} 000110 \\ \oplus \\ 010011 \\ \hline 010101 \end{array}$	$C_2 = 010101$ $\oplus$ $P(x) 100101$ $\hline r_3 = 010101$ <p>as <math>C_3 &lt; P(x)</math></p>
TP 3	$b_1 = 0$	$C_3 = 2r_3 + 0 = 101010$	$C_3 = 101010$ $\oplus$ $P(x) 100101$ $\hline r_4 = 001111$
TP 4	$b_0 = 1$	$C_4 = 2r_4 + A =$ $\begin{array}{r} 011110 \\ \oplus \\ 010011 \\ \hline 001101 \end{array}$	$C_4 = 001101$ $\oplus$ $P(x) 100101$ $\hline r_5 = 001101$

Checking:  $(x^4 + x + 1) * (x^4 + x^2 + 1) = (x^3 + x^2 + 1)$ , accordingly binary display of this polynomial – 01101<sub>2</sub>.

This algorithm was tested on Nexys 4 Artix-7 FPGA Board. Figure 2 contains diagram for encoding and decoding the number A in hexadecimal.

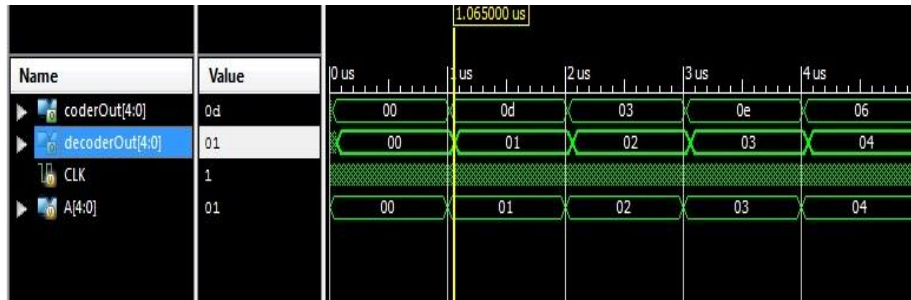


Fig. 2 The timing diagram of the algorithm for an 8-bit number

Table 2. The number of resources used in encoding and decoding as a percentage

Slice Logic Utilization	% of the FPGA resource used when encoding and decoding 4-bit code	% of the FPGA resource used when encoding and decoding 8-bit code	% of the FPGA resource used when encoding and decoding 12-bit code	% of the FPGA resource used when encoding and decoding 24-bit code
Number of Slice Registers	0.02%	0.1%	0.39%	1.25%
Number of Slice LUTs	0.05%	0.33%	1.48%	4.9%
Number of bonded IOBs	7%	13%	19%	36%
Number of BUFG/BUFG CTRLs	3%	3%	3%	3%

Table 2 shows the number of resources used in encoding and decoding processes in percents.

#### 4. Conclusions

The precondition research for is the growing need to create efficient hardware solutions for cryptographic transformations and the difficulties that arise in using the radix numeration system.

As was stated above, the basic privileges of nonpositional number system applying is the absence of transfer of digits in the operations of addition and multiplication, and, consequently, the parallel operations possibility on each of the bases of the system, which significantly speeds up the calculation process. It stands to mention that most modern general-purpose processors are not able to effectively perform nonpositional number system calculations.

For the most effective implementation of computing devices based on the residual number system, it is required to develop non-standard circuit solutions that effectively perform calculations in a nonpositional number system.

#### References

1. A. Poschmann, *Lightweight Cryptography – Cryptographic Engineering for a Pervasive World*. IACR ePrint archive 2009, 516 p., (2009).
2. J. Guajardo, S. Kumar, C. Paar, J. Pelzl, Efficient software-implementation of finite fields with applications to cryptography, *Acta Applicandae Mathematica*, Vol. 93, Iss. 1-3, pp 3-32, 2006.
3. Kalimoldayev M., Tynymbayev S., Gnatyuk S., Ibraimov M., Magzom M. The device for multiplying polynomials modulo an irreducible polynomial *News of the National Academy of Sciences of the Republic of Kazakhstan, Series of Geology and Technical Sciences*, 2 (434), pp. 199-205 (2019).
4. Tynymbayev S., Gnatyuk S.A., Aitkhozhayeva Y.Z., Berdibayev R.S., Namazbayev T.A. Modular reduction based on the divider by blocking negative remainders, *News of the National Academy of Sciences of the Republic of Kazakhstan, Series of Geology and Technical Sciences*, 2 (434), pp. 238-248, 2019.
5. N. Gura, Comparing Elliptic Curve Cryptography and RSA on 8-bit CPUs'' *Proc. 6th Int'l Workshop Cryptographic Hardware and Embedded Systems (CHES 04) LNCS 3156*. – Springer (2004).
6. D. Schinianakis., T. Stouraitis, *RNS-based RSA and ECC cryptography basic operations, algorithms, and hardware*, *Embedded Systems Design with Special Arithmetic and Number Systems*, Springer (2017).
7. Hu Z., Gnatyuk S., Kovtun M., Seilova N. Method of searching birationally equivalent Edwards curves over binary fields, *Advances in Intelligent Systems and Computing*, Vol. 754, pp. 309-319, 2018.
8. S. Gnatyuk, M. Kovtun, V. Kovtun, A. Okhrimenko, Search method development of birationally equivalent binary Edwards curves for binary Weierstrass curves from DSTU 4145-2002, *Proceedings of 2nd Intern. Scientific-Practical Conf. on the Problems of Infocommunications. Science and Technology (PIC S&T 2015)*, Kharkiv, Ukraine, pp. 5-8 (2015).
9. M. Kalimoldayev, R. Biyashev, S. Nyssanbayeva, Y. Begimbayeva, Modification of the digital signature, developed on the nonpositional polynomial notations, *Eurasian Journal of Mathematical and Computer Applications*, ISSN 2306–6172, Volume 4 , Issue 2 (2016), pp. 33-38 (2016).

10. R. Biyashev, M. Kalimoldayev, S. Nyssanbayeva, M. Magzom, Development of an encryption algorithm based on nonpositional polynomial notations, Proceedings of the International Conference on Advanced Materials Science and Environmental Engineering pp. 112-118 (2016).
11. S. Gnatyuk, A. Okhrimenko, M. Kovtun, T. Gancarczyk, V. Karpinskiy, Method of Algorithm Building for Modular Reducing by Irreducible Polynomial, Proceedings of the 16th International Conference on Control, Automation and Systems, Gyeongju, Korea, pp. 1476-1479 (2016).
12. S. Gnatyuk, V. Kinzeryavyy, M. Iavich, D. Prysiaznyi, Kh. Yubuzova, High-Performance Reliable Block Encryption Algorithms Secured against Linear and Differential Cryptanalytic Attacks, CEUR Workshop Proceedings (Proceedings of the 14th International Conference on ICT in Education, Research and Industrial Applications. Integration, Harmonization and Knowledge Transfer, Kyiv, Ukraine, May 14-17, 2018), vol. 2104, pp. 657-668 (2018).
13. M. Ciet, M. Neve, E. Peeters, J. Quisquater, Parallel FPGA implementation of RSA with residue number systems-can side-channel threats be avoided?, In 2003 46th Midwest Symposium on Circuits and Systems, Vol. 2, pp. 806-810, 2003.
14. R. Hobson, P. McGinn, Co-processor for performing modular multiplication, U.S. Patent No. 6,209,016. 27 Mar. 2001.
15. V. Krasnobayev, S. Koshman, A. Yanko, A. Martynenko, Method of Error Control of the Information Presented in the Modular Number System, Problems of Infocommunications. Science and Technology: International Scientific-Practical Conference, pp. 35-42, 2018.
16. V. Krasnobayev, S. Koshman, A Method for Operational Diagnosis of Data Represented in a Residue Number System, Cybernetics and Systems Analysis, vol. 54, issue 2, pp. 336-344, 2018.

# Multi-Fragmental Markov Models of Information and Control Systems Safety Considering Elimination of Hardware-Software Faults

Vyacheslav Kharchenko<sup>1,3</sup> [0000-0001-5352-077X], Yuriy Ponochovnyi<sup>1,2</sup> [0000-0002-6856-2013],  
Artem Boyarchuk<sup>1</sup> [0000-0001-7349-1371], Anton Andrashov<sup>3</sup> [0000-0003-2238-0449]

<sup>1</sup> National Aerospace University KhAI, Kharkiv, Ukraine

V.Kharchenko@csn.khai.edu, a.boyarchuk@csn.khai.edu

<sup>2</sup> Poltava State Agrarian Academy PSAA, Poltava, Ukraine

yuriy.ponch@gmail.com

<sup>3</sup> Research and Production Company Radiy, Kirovograd, Ukraine

a.andrashov@radiy.com

**Abstract.** The information and control systems of Nuclear Power Plant and other safety critical systems are considered as a set of three independent hardware channels including online testing system. Nuclear Power Plant information and control systems design on programmable platforms is rigidly tied to the V-model of the life cycle. Functional safety and availability during its life cycle are assessed using Markov and multi-fragmental models. Multi-fragmental models are used to assess the availability function and proof test period. The multi-fragmental model MICS31 contains an absorbing state in case of hidden faults and allows evaluating risks of “hidden” unavailability. The MICS41 model simulates the “migration” of states with undetected failures into states with detected faults. Results of multi-fragmental modeling (models MICS31 and MICS42) are compared to evaluate proof test period taking into account requirements for SIL3 level and limiting values of hidden fault probabilities.

**Keywords:** Multi-Fragmental Models, Functional Safety Modeling, Information and Control System, Undetected Software Failure

## 1 Introduction

For different classes of critical systems (medical equipment, banking systems, road, air, railway transport and nuclear power plants) very strict requirements have been developed. These requirements determine both the system characteristics from the group of non-functional requirements (availability, reliability, safety, etc.) and the content of the life cycle phases. During the development cycle, it is possible to change

the architecture of the information and control system (ICS) of the Nuclear Power Plant (NPP) project and correct the parameters of its elements. Such actions require justification, which uses special mathematical models to confirm the fulfillment of design requirements.

This paper discusses the class of the information and control systems on programmable platforms, which are used in the reactor protection system of NPP in normal operation. This class of information and control system is based on the 2oo3 architecture without versioning with the control system and is described in detail in [1,2]. Expansion of the previously reviewed model consists of detailing the diagnostic procedures. This paper discusses the separate diagnosis of hardware and software with  $DC_{HW}$  and  $DC_{SW}$  parameters (DC is diagnostic coverage). As a separate process, regular proof tests are highlighted, during which latent hardware (HW) and software (SW) faults, that are not detected by the integrated control system, are detected.

Studies carried out in [3] have shown that achievement of the requirements of industrial systems on proof test  $T_{Areq} \geq 3$  years' period can be by influencing parameters of the functional safety of SW (reducing an intensity of dangerous SW  $\lambda_{DS}$  failure or increasing the completeness of control of dangerous SW  $DC_S$  failure). For information and control systems on programmable platforms, SW faults (architectural project faults) are entered into the system of bug tracking after their detection and eliminated within a certain time interval. The elimination of the software fault (assuming no new faults are introduced) causes a decrease in SW failure rate, as shown in [4,5]. To adequately display the elimination of SW faults and reduce the failure rate in studies [6], it was suggested to use the mathematical apparatus of multi-fragmental modeling.

At first glance, the elimination of software faults may cause a desire to use the information and control system project with the initial high intensity of dangerous SW failures, because faults will be identified and eliminated over the time. But this decision should be justified by the results of the study of the corresponding models of the information and control system with the elimination of faults causing dangerous SW failures.

In this paper, multi-fragmental models of functioning of the information and control system under the conditions of manifestation of dangerous HW and SW failures and elimination of identified SW faults are studied. For each model, graduated and oriented graphs are constructed; using the Matlab functions, systems of Kolmogorov-Chapman differential equations are constructed and solved. As a result, the values of the proof test  $T_{Areq}$  period for the SIL3 level and input parameters are obtained, at which the condition  $T_{Areq} \geq 3$  years for industrial systems is satisfied.

## 2 Approach and Modeling Technique

### 2.1. Model Specification

In this paper we develop six models using Markov process theory as shown in Table 1. Models MICS01 and MICS02 were studied at the papers [1] with the assumption of manifestation of only dangerous HW failures and only  $DC_H$  parameter.



We discuss in this work the separate diagnosis of hardware and software with  $DC_{HW}$  and  $DC_{SW}$  parameters.

**Table 1.** Functional safety models of the information and control system NPP

General characteristics of the model	Model specification	Conventional notions
A) Markov model for evaluating the functional safety of the information and control system with an absorbing state	- three groups of states (without manifestation of SW fault, with detected SW failure and with undetected SW failure) - there is one absorbing state (output only after the proof test)	Mics01
B) Markov model for evaluating the functional safety of the information and control system with the migration of hidden failures	- three groups of states (without manifestation of SW fault, with detected SW failure and with undetected SW failure) - there is no absorbing state (after the manifestation of the undetected failure, its "migration" is possible before the proof test)	Mics02
C) Multi-fragmental models for evaluating functional safety of the information and control system with incomplete elimination of design faults	- several fragments, in each fragment there are three groups of states - there is the absorbing state in each fragment (output only after the proof test)	Mics31
	- several fragments, in each fragment there are three groups of states - there are no absorbing states (after the manifestation of the undetected failure, its "migration" is possible before the proof test)	Mics41
D) Multi-fragmental models for evaluating functional safety of the information and control system with incomplete elimination of design faults	- several fragments, in the first fragments there are three groups of states - in the last fragment, there are two groups of states, since all SW faults are eliminated - there is the absorbing state in each fragment (output only after the proof test)	Mics32
	- several fragments, in the first fragments there are three groups of states - in the last fragment, there are two groups of states, since all SW faults are eliminated - there are no absorbing states (after the manifestation of the undetected failure, its "migration" is possible before the proof test)	Mics42

The assumptions during models building are as follows:

- the events of failures and restoration of hardware channels and software (until the fault is eliminated) constitute of the simplest flows (stationary, ordinary and without aftereffect), with the corresponding constant  $\lambda_{HW}$ ,  $\lambda_{SW}$  (failure rate) and  $\mu_{HW}$ ,  $\mu_{SW}$  (recovery intensity) parameters;
- the system uses identical hardware channels with the same failure rates;
- the failure rate of the majority body and the control system is negligibly small and these systems are assumed to be absolutely reliable in the considered model;
- the model considers only dangerous failures of hardware channels of the information and control system and SW information and control system, the intensity of

the dangerous failures is estimated according to the method [2] and data obtained for similar systems [9] as  $\lambda_{DHW} = 0.497 * \lambda_{HW}$ ;  $\lambda_{DSW} = 0.476 * \lambda_{SW}$ ;

- when diagnosing a part of dangerous failures, the intensity of detected dangerous failures is  $\lambda_{DDHW} = \lambda_{DHW} * DC_{HW}$ , and the intensity of undetected dangerous failures.

## 2.2. Multi-Fragmental Model for Evaluating the Functional Safety of the Information and Control System with the Absorbing States

MICS31 multi-fragmental model is improved in comparison with MICS01 and contains absorbing states in each fragment. The application of the multi-fragmental principle [6] allows us to adequately make the model of the elimination of design faults with the subsequent decrease in the intensity of dangerous SW failures. The graduated graph of the model is presented in Fig.1. The two-fragmental model describing the operation of the information and control system, in the course of which one design fault is eliminated, is considered. Each fragment of the model contains 25 states: S0 ... S24 in the initial F0 fragment and S25 ... S49 in the final F1 fragment. The initial operation of the system is described by the change of states, as in MICS01 model, but after detecting the dangerous SW failure, which manifests itself with  $\lambda_{DS0}$  intensity, the mechanism for its elimination is initiated, after which the system goes into the new fragment of F1 states, which is modeled by the corresponding S18 → S25, S19 → S26, S20 → S28, S21 → S29, S22 → S31, S23 → S32, S24 → S33 transitions with  $\mu_{SR} > \mu_S$  intensity.

In the new fragment, the system functions in the same way as described for MICS01 model [1] (taking into account the “shift” of state numbering by 25). At the same time, in F1 fragment, the intensity of the manifestation of dangerous SW failures is equal to  $\lambda_{DS1}$ , and is defined as:

$$\lambda_{DSi} = \lambda_{DSi-1} - \Delta\lambda_{DS} \quad (1)$$

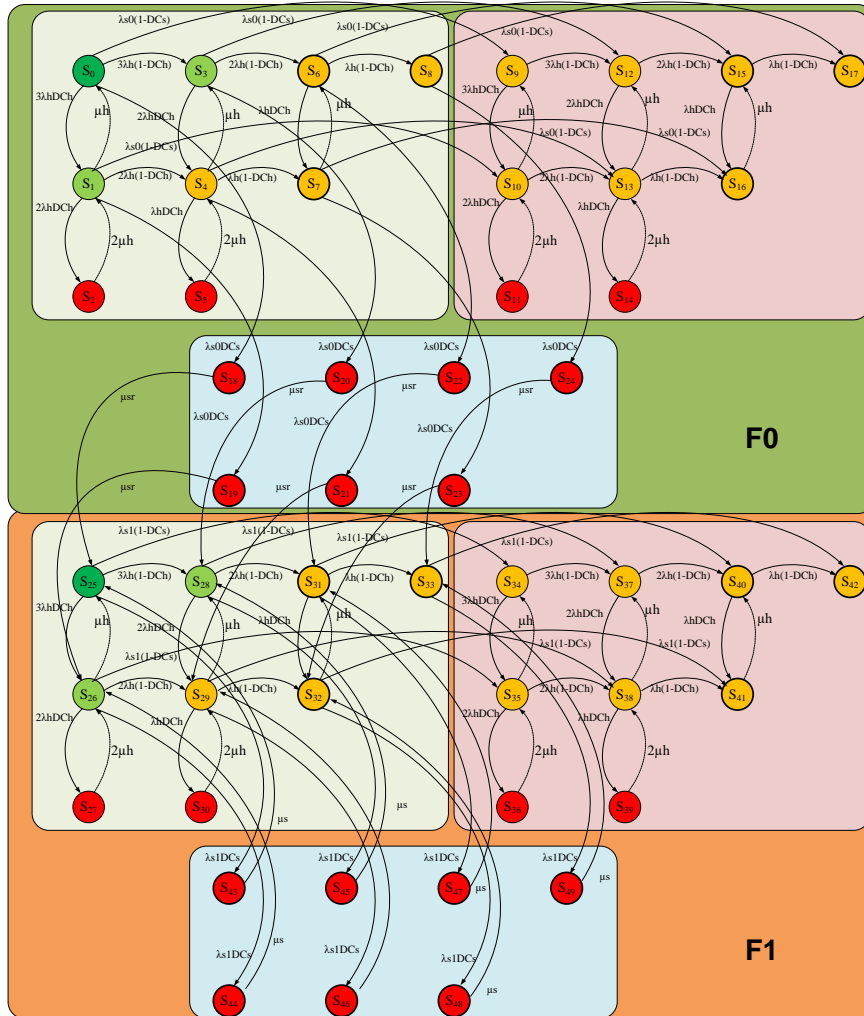
Since design faults remain in the system, after manifestation and detection of the dangerous SW failure, the system restarts to eliminate its consequences of  $\mu_S$  intensity, which is modeled by S41 → S25, S42 → S26, S44 → S28, S45 → S29, S47 → S31, S48 → S32, S49 → S33 transitions.

In all fragments of MICS31 model, there are absorbing states: S17 in F0 fragment and S42 in F1 fragment.

The availability function taking into account dangerous failures is defined as (2):

$$A(t) = P_0(t) + P_1(t) + P_3(t) + P_{25}(t) + P_{26}(t) + P_{28}(t). \quad (2)$$

Baseline conditions:  $t = 0, P_0(0) = 1, P_1(0) \dots P_{49}(0) = 0$ .

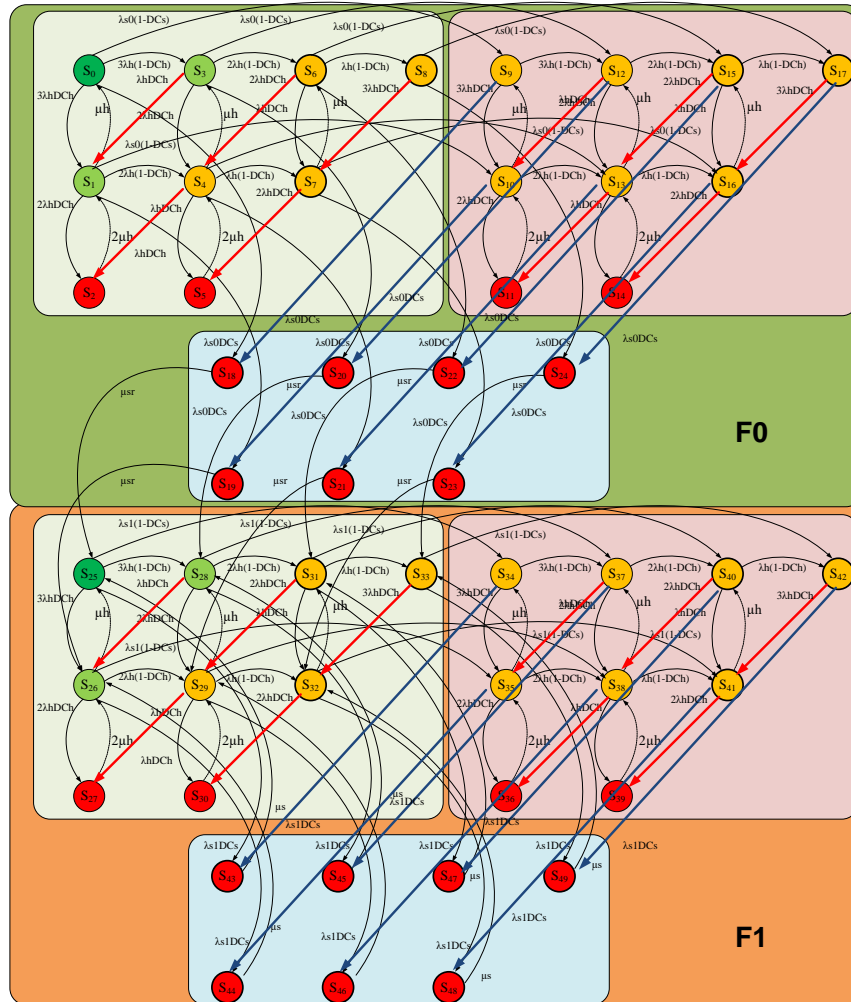


**Fig. 1.** Marked graph of ICS model with absorbing states and elimination one SW fault

### 2.3. Multi-Fragmental Model for Evaluating the Functional Safety of the Information and Control System with the Migration of Failures

In MICS41 multi-fragmental model, the assumption of the “migration” of hidden failures into decisive ones, described earlier for MICS02 model, was adopted. There are no absorbing states on the graduated graph of the model (Fig. 2). Transitions from the undetected dangerous failure state are simulated without additional measures (proof test). This model also deals with the elimination of the decisive DC SW after its manifestation. This is modeled as in MICS31 model by  $S_{18} \rightarrow S_{25}$ ,  $S_{19} \rightarrow S_{26}$ ,  $S_{20} \rightarrow S_{28}$ ,  $S_{21} \rightarrow S_{29}$ ,  $S_{22} \rightarrow S_{31}$ ,  $S_{23} \rightarrow S_{32}$ ,  $S_{24} \rightarrow S_{33}$  transitions with  $\mu_{sr}$

intensity. In the last F1 fragment, system recovery after the dangerous SW failure is performed by restarting with  $\mu s$  intensity without its elimination.



**Fig. 2.** Marked graph of multi-fragmental ICS model with the migration of hidden failures MICS41

The number and nature of the states of the MICS41 model graph are identical to the previous MICS31 model. In addition to the MICS31 model, transitions have been added that simulate the migration of hidden HW failures:  $S_3 \rightarrow S_1$ ,  $S_4 \rightarrow S_2$ ,  $S_6 \rightarrow S_4$ ,  $S_7 \rightarrow S_5$ ,  $S_8 \rightarrow S_7$ ,  $S_{12} \rightarrow S_{10}$ ,  $S_{13} \rightarrow S_{11}$ ,  $S_{15} \rightarrow S_{13}$ ,  $S_{16} \rightarrow S_{14}$ ,  $S_{17} \rightarrow S_6$ ; transitions that simulate the migration of hidden SW failures:  $S_9 \rightarrow S_{18}$ ,  $S_{10} \rightarrow S_{19}$ ,  $S_{12} \rightarrow S_{20}$ ,  $S_{13} \rightarrow S_{21}$ ,  $S_{15} \rightarrow S_{22}$ ,  $S_{16} \rightarrow S_{23}$ ,  $S_{17} \rightarrow S_{24}$  (for initial fragment F0). For F1 fragment migration of hidden HW failures is presented in transitions  $S_{28} \rightarrow S_{26}$ ,  $S_{29} \rightarrow S_{27}$ ,  $S_{31} \rightarrow S_{29}$ ,  $S_{32} \rightarrow S_{30}$ ,  $S_{33} \rightarrow S_{32}$ ,  $S_{37} \rightarrow S_{35}$ ,  $S_{38} \rightarrow S_{36}$ ,  $S_{40} \rightarrow S_{38}$ ,

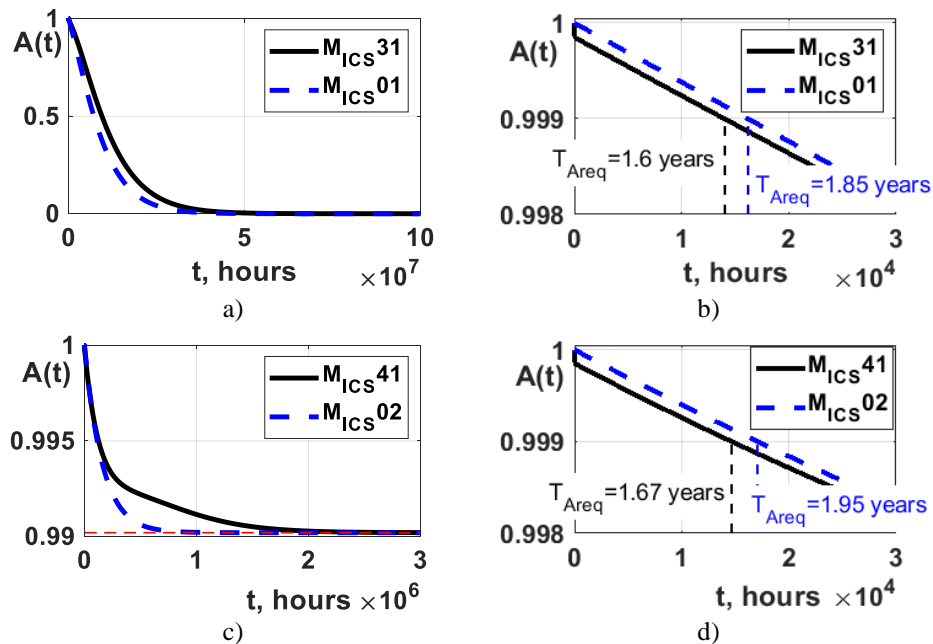
S41→S39, S42→S41; migration of hidden SW failures is presented in transitions S34→S43, S35→S44, S37→S45, S38→S46, S40→S47, S41→S48, S42→S49.

#### 4 Simulation and Comparative Analysis

The calculation of the availability indicators is performed for the input data from Table 2. To construct the matrix of the Kolmogorov-Chapman system of differential equations, we use the matrix A function [8]. The Kolmogorov solution was performed in the Matlab system using the ode15s method [9] for the time interval of [0 ... 50000] hours. The results of the solution are presented in the graphical form in Fig. 3.

**Table 2.** Values of input parameters of simulation processing

#	Parameter	Base value
1	$\lambda_{Dh}$	46.04622e-6 (1/hour)
2	DCh	0.9989
3	$\mu_h=1/MRTh$	1/8 = 0.125 (1/hour)
4	$\lambda_{Ds}$	6.27903e-6 (1/hour)
5	DCs	0.9902
6	$\mu_s=1/MRTs$	10 (1/hour)
7	$\mu_{sr}$	1/24=0.04167 (1/hour)
8	$\Delta\lambda_{Ds}$	1.5697575e-06 (1/hour)



**Fig. 3.** The results of modeling of availability function of models  $M_{ICS31}$  (a),  $M_{ICS41}$  (c) and determining  $T_{Areq}$  interval with an error  $\xi=1e-6$  (b,d)

The presence of absorbing states in MICS31 model causes the availability function behavior similar to MICS01 model - it's striving to zero. But it is obvious that the elimination of design faults slows the decrease in availability to zero. The decrease in the level of availability below 0.999 occurs after 13992 hours or 1.6 years. This value is worse than in MICS01 model and does not meet the standard for industrial systems in 3 years or 26298 hours.

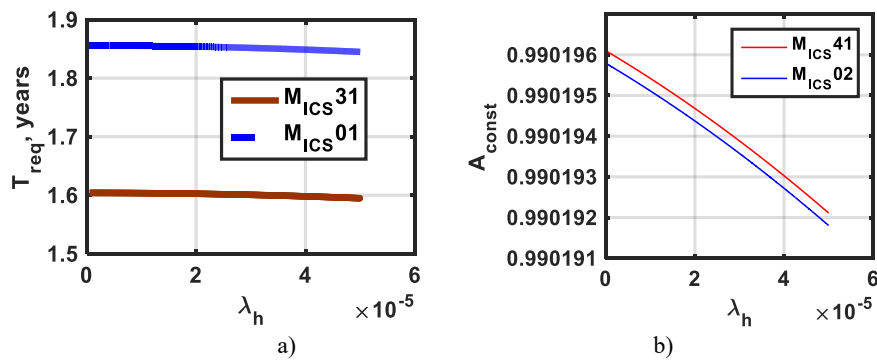
The availability function of MICS41 model is approaching to the stationary value of 0.9901, at that it goes into the established mode on  $10^6$  hours later than the result of the single-fragment MICS02 model. The decrease in the level of availability below 0.999 occurs after 14666 hours or 1.67 years. This value is worse than in MICS02 model and does not meet the standard for industrial systems in 3 years or 26298 hours.

For MICS31 and MICS41 models, the additional studies were conducted to determine the values of the input parameters at which  $T_{Areq} \geq 26298$  hours. The intervals for changing the input parameters are the same as for MICS01 model and are shown in Table 3.

**Table 3.** Variable input parameters of the ICS model

#	Variable parameter	Designation	Values series
1	The rate of dangerous hardware failures	$\lambda_{DH}$	$[0.05\dots5]e^{-5}$ (1/hour)
2	Diagnosing dangerous hardware failures control completeness	$DC_H$	[0..1]
3	Diagnosing dangerous software failures control completeness	$DC_S$	[0..1]

Cyclic scripts for Matlab were built to calculate the models. The results of the research are shown as graphical dependences in Fig. 4 – Fig. 6.

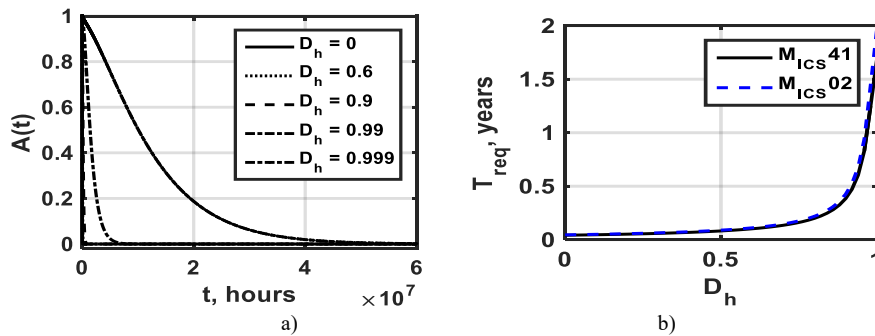


**Fig. 4.** Graphs for determining the  $T_{Areq}$  interval of MICS31 models (a) and the established value of the availability function of MICS41 model (b) for different values of the input  $\lambda_{DH}$  parameter

The results of the influence of values of the input  $\lambda_{DH}$  parameter on the behavior of the availability function of MICS31 model are shown in Fig.4 (a). With the decrease

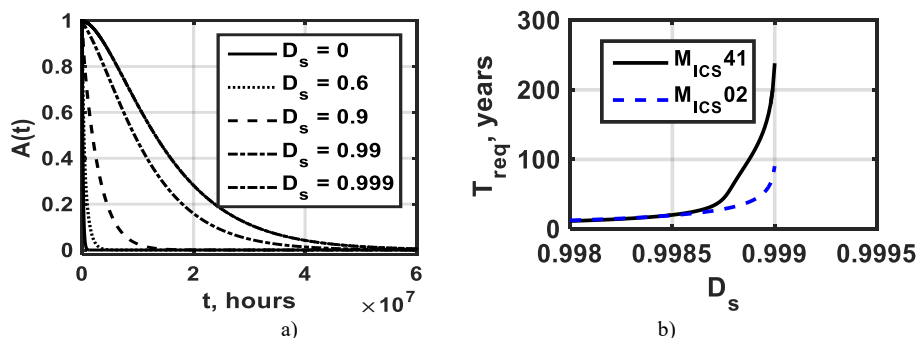
in the intensity of dangerous failures of HW, the reduction in availability to zero slows down. But taking into account the scale on the horizontal axis ( $10^8$  hours), this result is not applicable in practice.

The results of the influence of values of the input  $\lambda_{DH}$  parameter on the established value of the function of MICS02 model are shown in Fig. 4 (b). With the decrease in the intensity of dangerous HW failures,  $A_{const}$  increases insignificantly (6 decimal places), which cannot be used for practical application. The result presented in Fig. 4(b) is also practically not interesting since a change of  $\lambda_{DH}$  by two orders of magnitude does not allow assuring  $T_{Areq} \geq 26298$  hours' condition.



**Fig. 5.** Charts of the availability function of MICS31 model (a), interval  $T_{Areq}$  of MICS41 model (b) for different values of input parameter  $DC_H$

The value of the input  $DC_H$  parameter of MICS31 model affects the speed of the transition of the availability function to the established value: with the increase in  $DC_H$  from 0.99 to 0.999, the descent of availability to zero slows down by  $4 \cdot 10^7$  hours. The value of the input  $DC_H$  parameter of MICS41 model practically does not affect the speed of the transition of the availability function to the established value. On the other hand, the change in  $DC_H$  from 0 to 1 also causes a change in  $A_{const}$  within  $[0..0.9902]$ . The result presented in Fig.5 (b) is also important for practice, since after modeling it becomes obvious that the increase in  $DC_H$  to 1 does not allow to ensure  $T_{Areq} \geq 26298$  hours' condition (as in MICS31 model).



**Fig. 6.** Charts of availability function of MICS31 model (a), interval determination  $T_{Areq}$  MICS41 model (b) for different values of the input parameter  $DC_s$

The results of the influence of values of the input  $DC_S$  parameter on the behavior of the availability function of MICS31 model are shown in Fig.6 (a). With the increase in the test coverage of dangerous SW failures by the order of magnitude (from  $DC_S = 0.99$  to  $DC_S = 0.999$ , etc.), the availability function goes to zero level several times slower (from  $5 * 10^7$  to  $6 * 10^7$  hours). The following result is important for practice: starting from  $DC_S = 0.9947$  value,  $T_{Areq} \geq 26298$  hours' condition is provided.

The results of the influence of values of the input  $DC_S$  parameter on the behavior of the availability function of the model are shown in Fig.6 (b). The dependence of  $A_{const}$  on  $DC_S$  for MICS41 model is linear and is not shown in the graph. With  $DC_S = 1 \rightarrow A_{const} = 0.9999924$ . The value satisfying the requirements of SIL3 ( $A_{const} = 0.99909$ ) is achieved at  $DC_S = 0.9991$ . Theoretically, this allows us to talk about systems without a proof test, but from the practical point of view, it is very difficult and costly to achieve such level of control completeness.

The results are shown in Fig.6 (b) illustrate the maintenance of  $T_{Areq} \geq 3$  years' condition starting from  $DC_S = 0.9942$  value. And what is more interesting, in Fig. 6(b) it is shown that in  $DC_S = [0.998 \dots 0.9991]$  interval the multi-fragmental MICS41 model over the proof test period significantly benefits the single-fragmental MICS02 model.

## 5 Conclusions

In the article, the multi-fragmental model architecture for information and control systems of NPP 2oo3 is presented with occurred HW and SW faults and eliminating of hidden faults.

Analysis of the obtained results of modeling the availability of the information and control systems of NPP architecture with partially eliminating of design faults has shown that:

a) for the multi-fragmental MICS31 model with absorbing the decrease in the availability function to zero is significant. For typical values of input parameters (Table 2), the fulfillment of SIL3 requirements is guaranteed in  $[0 \dots 1.6 \text{ years}]$  interval. The increase in the interest  $T_{proof \text{ test}}$  interval of up to 3 years is possible with the increase in the control completeness to detect dangerous SW failures to  $DC_S = 0.9947$  level and higher;

b) the multi-fragmental MICS41 model is characterized by the decrease in the availability function to the stationary  $A_{const}$  value. For typical values of input parameters (Table 2), the fulfillment of SIL3 requirements is guaranteed in  $[0 \dots 1.67 \text{ years}]$  interval. The increase in the interest  $T_{proof \text{ test}}$  interval of up to 3 years is possible with the increase in the control completeness to detect dangerous SW failures to  $DC_S = 0.9942$  level. Starting from  $DC_S = 0.9991$ , SIL3 requirements are guaranteed to be fulfilled without additional proof tests.

The developed mathematical models make it possible to assess the fulfillment of the requirements for the functional safety of the designed information and control system. Application of the developed models is advisable in specific time counts tied to the phases of the V-model of the project life cycle (and possibly to the separate layer of the V-model).



The future step includes: it is necessary to put in order and regulate the operations of choosing one of several models for the specific design phase, tight time reference to the beginning/end of the life cycle phase, substantiation of assumptions, changes in the structure and parameters of models in one method.

## References

1. Bulba, Y., Ponochovny, Y., Sklyar, V., Ivasiuk, A. Classification and research of the reactor protection instrumentation and control system functional safety Markov models in a normal operation mode. *CEUR Workshop Proceedings*, 1614, 308-321 (2016)
2. IEC 61508-6:2010. Functional safety of electrical/electronic/programmable electronic safety-related systems, Part 6: Guidelines on the application of IEC 61508-2,3 (2010)
3. Langeron, Y. Barros, A. Grall, A. Berenguer, C. Combination of safety integrity levels (SILs): A study of IEC61508 merging rules. *Journal of Loss Prevention in the Process Industries* 21(4), 437-449 (2008)
4. Zhu, M. Pham, H. A software reliability model with time-dependent fault detection and fault removal. *Vietnam J Comput Sci* 3(2): 71-79 (2016)
5. Pham, H. Loglog fault-detection rate and testing coverage software reliability models subject to random environments. *Vietnam J. Comput. Sci.* 1(1), 39-45 (2014)
6. Kharchenko, V.; Butenko, V.; Odarushchenko, O., Sklyar, V.: Multifragmentation Markov Modeling of a Reactor Trip System. *ASME Journal of Nuclear Engineering and Radiation Science*, vol. 1 (3), 031005-031005-10 (2015)
7. D7.24-FSC(P3)-FMEDA-V6R0. Exida FMEDA Report of Project: Radiy FPGA-based Safety Controller (FSC) (2018)
8. Kharchenko, V., Ponochovnyi, Y., Boyarchuk, A., Brezhnev, E.: Resilience Assurance for Software-Based Space Systems with Online Patching: Two Cases. In: Zamojski W., Mazurkiewicz J., Sugier J., Walkowiak T., Kacprzyk J. (eds) *Dependability Engineering and Complex Systems. DepCoS-RELCOMEX 2016. Advances in Intelligent Systems and Computing*, vol 470, 267-278 (2016)
9. Ode15s: Solve stiff differential equations and DAEs - variable order method. <https://www.mathworks.com/help/matlab/ref/ode15s.html>, last accessed 2019/05/07

# Power-Oriented Checkability of Matrix and Pipeline Circuits in FPGA-Based Digital Components of Safety-Related Systems

Oleksandr Drozd, Viktor Antoniuk, Miroslav Drozd, Hanna Stepova

Institute of Computer Systems, Odessa National Polytechnic University,  
Avenue Shevchenko 1, 65044 Odessa, Ukraine

drozd@ukr.net, viktor.v.antoniuk@gmail.com, miroslav\_dr@mail.ru,  
hanna.suhak@gmail.com

**Abstract.** The checkability of the circuits is considered as a necessary condition for ensuring functional safety for safety-related systems based on the use of fault-tolerant solutions. The features of logical checkability, which is essential for testing, testable design and on-line testing of digital components of safety-related systems, are analyzed. Logical checkability is represented as structural, structurally functional and dual-mode, typical for critical applications. The problem of hidden faults is noted, which shows the lack of dual-mode checkability in the design of digital components based on matrix structures. The resource-based approach identifies this problem as a growth problem, the solution of which requires the reduction of matrix structures. The maximum reduction is achieved in bitwise pipelines. The limitations of logical checkability are shown in solving the problem of hidden faults under the conditions of the dominance of matrix structures and in the monitoring of faults in chains of the common signals. The success of green technologies in FPGA design created the conditions for the development of power-oriented checkability, which significantly complements the logical checkability of the circuits. An analytical evaluation of power-oriented checkability was obtained. The results of power-oriented checkability evaluation experiments are shown to be important for faults in chains of the common signals. Experiments were carried out for matrix and bitwise pipeline circuits using the example of multipliers of numbers. A comparative analysis of the results obtained.

**Keywords:** Safety-Related System, Digital Component, FPGA, Logical and Power-Oriented Checkability, Problem of the Hidden Faults, Resource-based Approach, Matrix Structure, Bitwise Pipeline, Faults in Chains of the Common Signals

## 1 Introduction

Instrumentation and control safety-related systems are an important part of high-risk objects, which are widely represented in the energy sector, on high-speed ground and air transport by power plants, power grids, vehicles and their infrastructures. These systems are aimed at ensuring functional safety of both the system and the control

object. They play an important role in preventing accidents at high-risk objects and in reducing losses in the event of an accident [1, 2].

Functional safety is based on the use of fault-tolerant solutions [3, 4].

However, a fault-tolerant solution is not yet fault-safe. Indeed, a fault-tolerant solution is resistant to the number of failures specified in the design. If the number of failures exceeds the established threshold, then the fault-tolerant solution is no longer fault-safe. Thus, on the way from fault tolerance to functional safety is another important characteristic of the component of safety-related system. This characteristic is checkability, i.e. the suitability of the component's circuit for its faults being checked [5, 6].

Safety-related systems are distinguished from the general number of computer systems by dividing the operating mode into normal and emergency. Modern technologies used in safety-related systems are aimed at maintaining the system and the object in a normal mode throughout the entire operation time. Therefore, the most critical emergency mode is rarely activated and is poorly understood. The main question that is posed throughout the normal mode is whether the safety-related system is ready to perform its basic functions, i.e. emergency mode functions to prevent accidents at the control object and mitigate the consequences of the accident [7, 8].

Setting of this question has the complete reasons which are based on a problem of the hidden faults. This problem is the accumulation of hidden faults over the course of an extended normal mode in the absence of input data, which may manifest these faults as an error of the calculated result. With the beginning of the emergency mode, the input data changes its character and manifests accumulated faults that reduce the fault tolerance of the system components and its functional safety. Faults occurring in emergency mode, i.e. abnormal faults do not contribute to countering the accident [9].

The absence of conditions for the manifestation of faults is explained by the lack of checkability of the circuit. Checkability is defined in relation to a particular type of checking. The most widely used logical checking, which identifies a fault by its manifestation in the form of an error of the analyzed result. Logical checking is performed within the frame of its corresponding logical checkability, which can be structural, structurally functional, and dual-mode structurally functional [10, 11].

Structural checkability, which is determined only by the structure of the scheme, is testability, i.e. ability of the circuit to being tested in the pauses of its work. Known testable design is aimed at improving the structural checkability of circuits [12, 13].

In the process of performing operations, the circuit is characterized by structurally functional checkability, which depends on the structure of the circuit and on the input data. Structurally functional checkability creates the conditions for error detection by methods and means of on-line testing [14, 15].

Dual-mode structurally functional checkability is inherent to safety-related systems and is a consequence of the division of the operating mode into normal and emergency. This leads to different structurally functional checkability of digital circuits in normal and emergency mode due to the different input data received in these modes. Dual-mode structurally functional checkability consists in an ability of the circuit to show the abnormal faults in a normal mode. Dual-mode structurally functional checkability is part of the structurally functional checkability of the circuit in the normal mode, because it does not take into account faults that manifest themselves only in the normal mode and have no consequences in the emergency mode.

Dual-mode checkability is maximum with minimal difference of structurally functional checkability of the circuit in normal and emergency mode. This difference, supported by the various input data of the circuit in these modes, serves as a source for the problem of hidden faults [11].

This problem is better known for unsuccessful attempts to detect hidden faults by using imitation modes, i.e. recreation of the accident conditions to test the operation of the safety-related system and its components in emergency mode. Unauthorized activation of imitation modes by a person or malfunction more than once led to accident consequences [16, 17].

The presence of dangerous imitation modes in the arsenal of methods for solving the problem of hidden faults indicates a lack of confidence in the fault tolerance of the components used in safety-related system and is explained by the lack of checkability of the designed circuits.

Low structurally functional checkability of the circuit is due to its structural redundancy, which is a consequence of two main reasons: the need to use fault-tolerant solutions with significant structural redundancy; limited input data in normal mode. The first reason is objective, since fault-tolerant solutions are the basis for ensuring the functional safety of safety-related systems.

However, the problem of hidden faults is related to the second reason, which only seems to be objective. Indeed, it is objective only within the frame of traditional design of digital components based on matrix structures using parallel adders and comparators, iterative array multipliers and dividers [18].

These nodes process data in parallel codes on matrices of homogeneous operational elements. Parallel codes help distinguish the input data of the circuit in normal and emergency mode. The second reason can be eliminated by reducing the matrix structures based on the gain of the pipeline parallelism of circuit solutions. Modern digital components are built pipeline, but the pipeline sections are matrix nodes or their elements [19, 20].

The reduction of the matrix structure to one operational element in the pipeline section converts the digital component into a bitwise pipeline that performs operations in sequential codes. Register structures of the bitwise pipeline, which are elements of testable design (scanning registers), significantly increase the structurally functional checkability of the circuit in normal mode. Sequential codes align the variety of input data of the normal and emergency modes, significantly increasing the dual-mode structurally functional checkability of the circuits in safety-related systems.

At the same time, logical checkability has a number of limitations associated with the continued dominance of matrix structures in the design of digital components, as well as the problems of on-line testing.

These restrictions stimulate the search for other forms of checking and checkability of components used in safety-related systems.

It should be noted the successful development of digital components of safety-related systems based on the component approach [21, 22] and orientation to FPGA design [23, 24].

The sustainable development of green information technologies in power saving [25, 26] has created the prerequisites for the implementation of checking of the circuits within the frame of checkability in power consumption. Modern CAD systems have received tools for estimating the power consumption of FPGA projects.

Therefore, a number of issues arise related to the limited of logical checkability and expediency of developing the power-oriented checkability of the circuits, as well as perspectivity of digital components based on matrix structures and bitwise pipelines.

The purpose of this study is to evaluate the expediency of developing the power-oriented checkability of the circuits under the conditions of a developed logical checkability in relation to traditional matrix and perspective bitwise pipeline circuit solutions.

The second section analyzes the limitations in the logical checkability of circuits that justify the development of power-oriented checkability. The third section defines the analytical assessment of power-oriented checkability, taking into account the possibilities offered by modern CAD systems using the example of Quartus Prime [27]. The fourth section describes the results of experiments and their comparative analysis in assessment of power-oriented checkability for FPGA projects with matrix and bitwise pipeline circuits using the example of multipliers of numbers with different size.

## 2 Expediency of Power-Oriented Checkability Development

Logical checking has received a monopoly both in relation to testing digital circuits, and in the domain of their on-line testing. The long-term sustainable development of logical checking has created a powerful infrastructure of models, methods and tools that support further dominance. Under these conditions, the development of alternative forms of checking and appropriate checkability becomes justified and successful in the case of obtaining its own place, where logical checking and logical checkability are limited in efficiency, and the alternative approach demonstrates the desired positive effect.

The first condition for obtaining your own place requires evaluating the logical checking from the position of its lacks that are essential for critical applications.

Among the main challenges to logical checking, the problem of hidden faults is dominant. According to the resource-based approach [28], this problem is related to growth problems. The resource-based approach considers models, methods and means as resources and identifies three levels of their development: replication, diversification and autonomy.

Replication is the lowest level of resource development. Matrix structures are stamped from homogeneous elements at the replication level. For example, the iterative array multiplier of  $n$ -bit binary numbers consists of  $n^2$  operational elements, i.e. contains  $10^3$  operational elements for  $n = 32$  [29, 30].

Problems of functional safety can be solved, starting with the level of diversification. Therefore, computer systems in critical applications diversify the working mode, dividing it into normal and emergency, i.e. rise to the level of diversification. However, digital components continue to be stamped at the replication level based on matrix structures. This discrepancy in the level of development of the system and components leads to the problem of hidden faults.

The solution to the problem is to develop components to the level of the system, for example, by transforming matrix circuits into bitwise pipelines, reflecting the level of diversification.

However, the development of matrix structures is protected by a powerful infrastructure that has been created for decades, combining the best solutions in this area in the form of models, methods and tools, including CAD, focused on designing matrix circuits, extensive libraries of ready-made matrix nodes, tools of accelerated addition of parallel codes and iterative array multipliers built into FPGA chips [31, 32].

Matrix infrastructure significantly limits the efficiency of bitwise pipelines designed within this framework. Therefore, it is advisable to combine the development of bitwise pipelines with the reduction of matrix structures within the frame of the existing infrastructure. This solution is the use of truncated arithmetic operations in the processing of approximate data [33, 34].

An important feature of computer systems is their dominant development along the path of processing approximate data in floating-point formats [35, 36]. Safety-related systems are such computer systems that receive raw data from sensors. Measurement results related to approximate data are also the source data for critical domains of cyber-physical systems and Internet of Things systems [37, 38].

Truncated arithmetic operations almost twice simplify matrix structures. However, reducing computations complicates on-line testing, which, as a rule, are performed by residue checking [39, 40].

We can observe a tendency towards complication of objects of logical checking and, accordingly, a decrease in the logical checkability of matrix circuits and an increase in the complexity of methods and means for on-line testing.

The following lack of logical checking is associated with faults in the chains of common signals, for example, reset or clock signals. Such faults can fix the digital component circuit in a state that is identified by the logical control as correct. Logical checkability is not sufficient to detect such faults.

Power-oriented checkability, on the contrary, is sensitive to such faults, that reducing the number of switching signals and, accordingly, the dynamic component of power consumption.

In addition, power-oriented checkability increases in contrast to logical checkability with the complexity of the circuit and the corresponding increase in power consumption. This effect in floating-point matrix circuits is supported by the quadratic dependence of the circuit complexity on the range of the data being processed. Bitwise pipelines achieve this effect at an increased frequency.

It should also be noted that power-oriented checkability is not tied to digital circuits, as is the case for logical checkability, and can serve hybrid circuits that also contain analog nodes.

Thus, power-oriented checkability significantly complements logical checkability.

At the same time, power-oriented checkability receives significant support from FPGA design systems. These systems offer intelligent power assessment tools for FPGA projects. Such support from CAD is being improved as part of the successful development of green technologies [41, 42].

### 3 Analytical Assessment of the Power-Oriented Checkability

The checkability of the scheme can be estimated by the ratio of the set of impossible values of the checked indicator, i.e. values that can only be obtained under the action of a fault, to the total number of values. In the case of power-oriented checkability of the circuit, the checked indicator is the power consumption, which, taking into account the constant supply voltage, is fully characterized by the current consumption and therefore will be assessed by the current consumption. The sets of impossible and all values of the consumed current are represented by the volumes of the ranges of their change from the lowest to the highest value.

The existence of two ranges of impossible values that are below and above the allowable values of current consumption determines, respectively, the lower and upper power-oriented checkability of the circuit.

We consider lower power-oriented checkability  $C_{LPC}$ , which provides monitoring of common signals, such as reset or clock, and general control. Faults in chains of the common signals can significantly reduce power consumption in its dynamic component and are not always succumb to logical checking. The  $C_{LPC}$  checkability can be estimated taking into account the smallest  $I_{D\ MIN}$  and largest  $I_{D\ MAX}$  possible value of the dynamic component by the following formula:

$$C_{LPC} = I_{D\ MIN} / I_{D\ MAX}. \quad (1)$$

It should be noted that the sensors measure the total current consumption  $I_{T,S}$  and do not determine its dynamic component [43].

In Quartus Prime, a CAD system for designing digital circuits on Intel FPGA PLD, the current consumption of the project is estimated by the Power-Play Power Analyzer utility [44]. This utility estimates the total current consumption  $I_T$  of the PLD core and its dynamic  $I_D$  and static  $I_S$  components with an error  $\Delta I_T$ ,  $\Delta I_D$  and  $\Delta I_S$  at the level of 5%. In the process of measurement, the dynamic component can be estimated by the formula:  $I_{D,S} = I_{T,S} - I_S \pm \Delta I_{T,S} / 2 \pm \Delta I_S / 2$ , where  $\Delta I_{T,S}$  – current consumption measurement error,  $I_S$  and  $\Delta I_S$  – static component and its error determined previously by the utility Power-Play Power Analyzer. In case of proper functioning of the circuit  $I_{T,S} = I_T$  and  $I_{T,S} - I_S = I_D$ . In addition, as a rule  $\Delta I_{T,S} \leq \Delta I_T$ , i.e. we can accept  $\Delta I_{T,S} = \Delta I_T$ .

The Power-Play Power Analyzer utility estimates the consumption currents depending on the specified activity of the input signals, increasing the values of the  $I_T$  and  $I_D$  currents with increasing activity. It can be assumed that the  $I_{D\ MIN}$  and  $I_{D\ MAX}$  currents are achieved with zero and maximum activity of the input signals, respectively, i.e.

$$I_{D\ MIN} = I_{D,MIN} - (\Delta I_{T,MIN} + \Delta I_{S,MIN}) / 2; \quad (2)$$

$$I_{D\ MAX} = I_{D,MAX} + (\Delta I_{T,MAX} + \Delta I_{S,MAX}) / 2, \quad (3)$$

where the indices ".MIN" and ".MAX" mean currents and their errors at zero and maximum activity of the input signals, respectively.

Thus, the evaluation of the power consumption parameters of the project, performed by modeling in the Power-Play Power Analyzer utility, determines the lower power-oriented checkability of the circuit using the formulas (1) – (3) as follows:

$$C_{LPC} = (I_{D,MIN} - (\Delta I_{T,MIN} + \Delta I_{S,MIN}) / 2) / (I_{D,MAX} + (\Delta I_{T,MAX} + \Delta I_{S,MAX}) / 2). \quad (4)$$

This assessment requires experimental confirmation of the assumption made about the direct relationship between the  $I_{D\ MIN}$ ,  $I_{D\ MAX}$  currents and the activity of the input signals, since these currents are determined taking into account errors that reduce the direct dependence.

#### 4 Experimental Comparative Assessment in Power-Oriented Checkability of Iterative Array and Bitwise Pipeline Multipliers

Experimental assessment of the lower power-oriented checkability of the circuit is performed by comparing its values for iterative array and bitwise pipeline multipliers according to the results of their simulation, which was performed in Quartus Prime CAD. When carrying out simulations on FPGA Intel Max 10 10M50DAF672I7G [45], designs of multipliers with a size of input operands  $n = 8, 16, 24,$  and 32 bits were implemented. The  $A_I$  activity of the input information signals was set in the range from 0% to 100% of the value of the clock signal with an increment of 12.5%. The frequency of the clock signal was set as the maximum possible for a specific multiplier project.

Iterative array multipliers were designed in Intel's FPGA Quartus Prime CAD based on an Intellectual Property Core (IP-Core) LPM\_MULT of multiplier from the Library of Parameterized modules (LPM) that came with Quartus Prime. This IP-Core is implemented by CAD in the 9-bit multiplication blocks embedded in the FPGA Intel Max 10. The input and output user buffer registers were added to the LPM\_MULT IP-Core (Fig. 1).

Bitwise pipeline multipliers were designed in Quartus Prime based on the circuit described in [30], (Fig. 2).

The Time-Quest Timing Analyzer utility [46] was used to set the clock signal values and adjust the temporal parameters of the functioning for multipliers projects. The maximum possible frequency for each of the projects was determined by Quartus Prime as a result of the compilation of projects.

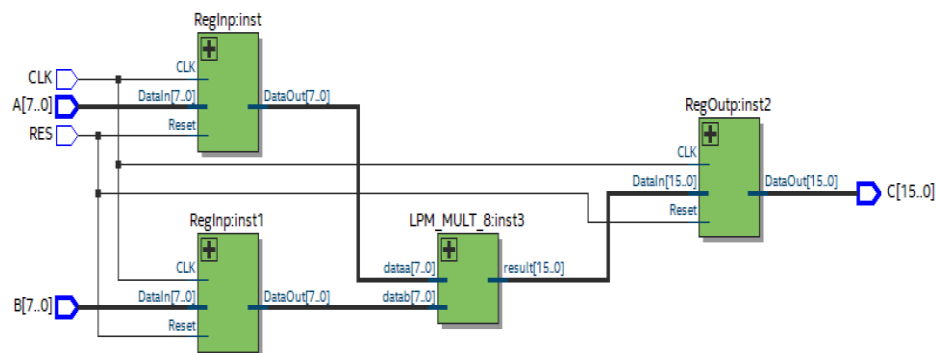
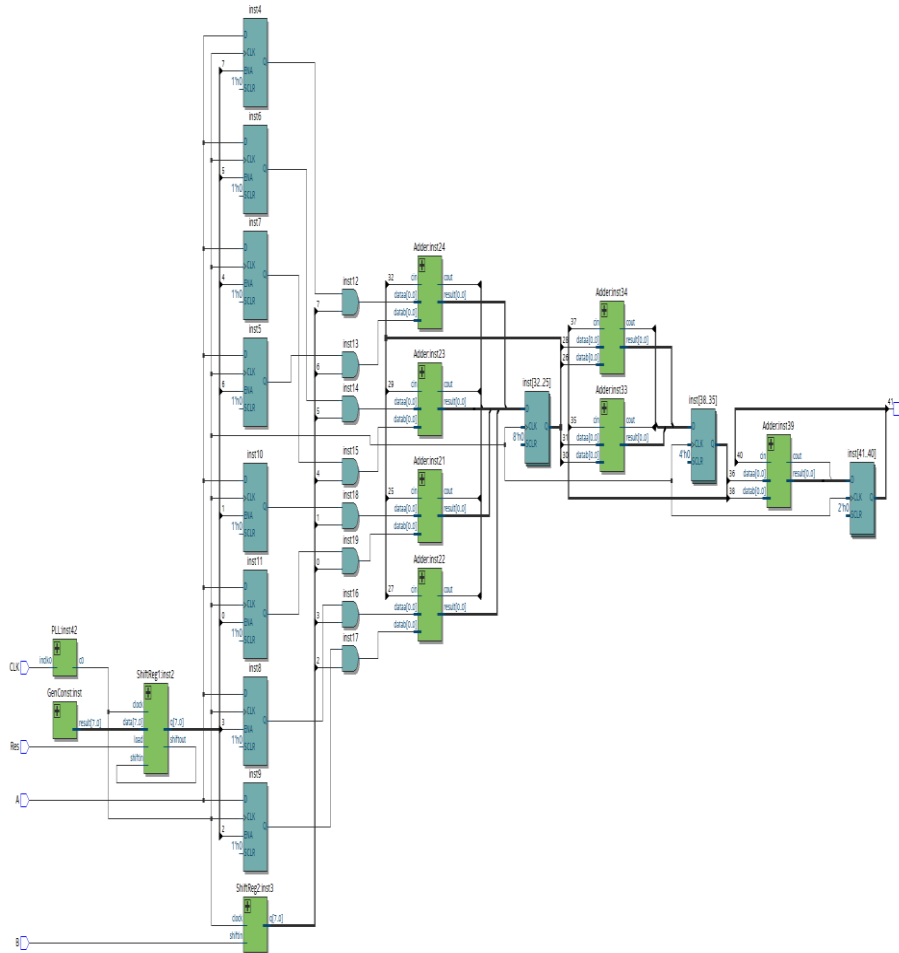


Fig. 1. An example of the project of an iterative array 8-bit multiplier



The Power-Play Power Analyzer utility was used to model the power consumption parameters of the multipliers. Before performing the simulation, it allows to set the parameters for calculating the activity of input and internal information signals.



**Fig. 2.** An example of the project of a bitwise pipeline 8-bit multiplier

The simulation results, which are the values of currents  $I_T$ ,  $I_S$ ,  $I_D$  of the FPGA core, are given in Table 1 and 2, respectively, for the iterative array and bitwise pipeline multipliers with a size of  $n$  from 8 to 32 bits.

The maximum clock frequency obtained as a result of modeling for the iterative array multipliers is 250 MHz, 232 MHz, 111 MHz and 100 MHz, respectively, at 8-, 16-, 24- and 32-bit operands.

For bitwise pipeline multipliers, the maximum frequency is the same for all digits and is 400 MHz.

**Tab. 1.** Experiment results for iterative array multipliers

$A_I$ , %	8 bit			16 bit			24 bit			32 bit		
	$I_D$ , mA	$I_S$ , mA	$I_T$ , mA	$I_D$ , mA	$I_S$ , mA	$I_T$ , mA	$I_D$ , mA	$I_S$ , mA	$I_T$ , mA	$I_D$ , mA	$I_S$ , mA	$I_T$ , mA
0	6.67	11.70	18.38	7.76	11.75	19.51	8.26	11.71	19.96	8.49	11.72	20.21
12.5	7.08	11.70	18.79	8.61	11.76	20.36	9.63	11.71	21.34	9.87	11.73	21.59
25	7.49	11.71	19.20	9.46	11.76	21.22	11.00	11.72	22.71	11.24	11.73	22.98
37.5	7.90	11.71	19.61	10.31	11.76	22.08	12.37	11.72	24.09	12.62	11.74	24.36
50	8.31	11.71	20.02	11.16	11.77	22.93	13.74	11.73	25.47	14.00	11.74	25.74
62.5	8.71	11.71	20.43	12.02	11.77	23.79	15.11	11.73	26.84	15.38	11.75	27.13
75	9.12	11.72	20.84	12.87	11.78	24.64	16.48	11.74	28.22	16.75	11.76	28.51
87.5	9.53	11.72	21.25	13.72	11.78	25.50	17.85	11.74	29.59	18.13	11.76	29.89
100	9.94	11.72	21.66	14.57	11.79	26.36	19.22	11.75	30.97	19.51	11.77	31.27

**Tab. 2.** Experiment results for pipeline multipliers

$A_I$ , %	8 bit			16 bit			24 bit			32 bit		
	$I_D$ , mA	$I_S$ , mA	$I_T$ , mA	$I_D$ , mA	$I_S$ , mA	$I_T$ , mA	$I_D$ , mA	$I_S$ , mA	$I_T$ , mA	$I_D$ , mA	$I_S$ , mA	$I_T$ , mA
0	10.28	11.67	21.95	11.77	11.67	23.44	16.94	11.68	28.62	17.94	11.68	29.63
12.5	10.53	11.67	22.20	12.26	11.67	23.93	17.61	11.68	29.29	18.86	11.69	30.55
25	10.78	11.67	22.44	12.75	11.67	24.42	18.28	11.69	29.97	19.78	11.69	31.46
37.5	11.02	11.67	22.69	13.23	11.67	24.91	18.95	11.69	30.64	20.69	11.69	32.38
50	11.27	11.67	22.94	13.72	11.68	25.40	19.63	11.69	31.32	21.61	11.69	33.30
62.5	11.40	11.67	23.07	13.94	11.68	25.61	19.92	11.69	31.61	22.01	11.70	33.71
75	11.53	11.67	23.20	14.15	11.68	25.83	20.21	11.69	31.90	22.41	11.70	34.11
87.5	11.65	11.67	23.33	14.36	11.68	26.04	20.50	11.69	32.20	22.82	11.70	34.52
100	11.78	11.67	23.46	14.57	11.68	26.25	20.80	11.69	32.49	23.22	11.70	34.92

The results of experimental verification of the minimum value of the current  $I_{D\ MIN}$  with zero input signal activity are presented in Table 3

**Tab. 3.**  $I_{D\ MIN}$  current values for different input signal activity

$A_I$ , %	Iterative array multipliers				Pipeline multipliers			
	8 bit	16 bit	24 bit	32 bit	8 bit	16 bit	24 bit	32 bit
0	5.92	6.98	7.47	7.69	9.44	10.89	15.93	16.91
12.5	6.32	7.81	8.80	9.04	9.68	11.37	16.59	17.80
25	6.72	8.64	10.14	10.37	9.93	11.85	17.24	18.70
37.5	7.12	9.46	11.47	11.72	10.16	12.32	17.89	19.59
50	7.52	10.29	12.81	13.06	10.40	12.79	18.55	20.49
62.5	7.91	11.13	14.15	14.41	10.53	13.01	18.84	20.87
75	8.31	11.96	15.48	15.74	10.66	13.21	19.12	21.26
87.5	8.71	12.79	16.82	17.09	10.78	13.42	19.40	21.66
100	9.11	13.62	18.15	18.43	10.90	13.62	19.70	22.05

The results of the checkability calculations according to the formula (4) for iterative array and bitwise pipeline multipliers are presented in Table 4.

**Tab. 4.** Power Consumption Checkability

$A_I$ , %	Iterative array multipliers				Pipeline multipliers			
	8 bit	16 bit	24 bit	32 bit	8 bit	16 bit	24 bit	32 bit
<b>0</b>	79.74	81.70	82.51	82.81	84.88	86.12	88.77	89.11
<b>12.5</b>	75.46	74.14	71.42	71.87	82.97	82.83	85.50	84.89
<b>25</b>	71.62	67.85	62.97	63.53	81.15	79.78	82.46	81.06
<b>37.5</b>	68.16	62.55	56.30	56.88	79.46	77.01	79.63	77.59
<b>50</b>	65.01	58.02	50.91	51.49	77.79	74.37	76.95	74.37
<b>62.5</b>	62.21	54.06	46.46	47.04	76.94	73.24	75.86	73.05
<b>75</b>	59.57	50.64	42.73	43.32	76.11	72.19	74.80	71.78
<b>87.5</b>	57.16	47.63	39.55	40.12	75.37	71.18	73.77	70.52
<b>100</b>	54.93	44.95	36.81	37.36	74.57	70.19	72.74	69.33

The table shows growth of the checkability with increase in size  $n$  and decrease of the  $A_I$  activity. The bitwise multiplier surpasses matrix circuits in a checkability and reduces it to a lesser extent with growth of the  $A_I$  activity.

## 5 Conclusions

The role of checkability of circuits increases in safety-related systems, since it is a necessary condition for converting fault-tolerant solutions into fault-safe.

The logical form of checkability has received the dominant development in testing and on-line testing of digital circuits as structural, structurally functional, and dual-mode structurally functional checkability, with the deficit of which the problem of hidden faults arises that is inherent to safety-related systems in the case of traditional component design based on matrix structures.

A drastic reduction of matrix structures in bitwise pipelines significantly improves logical checkability but requires significant changes in the design of digital components.

Another problem of logical checkability is faults in chains of the common signals, such as clock signals. These faults can fix the digital circuit in a state that is identified by the logical checking as correct.

The limitations of logical checkability in solving problems of hidden faults and monitoring of common signals stimulate the search for new forms of checkability.

The success of green technologies in FPGA design has created the conditions for the development of power-oriented checkability, which allows to detect faults in chains of the common signals by reducing the dynamic component of energy consumption.

Analytical evaluation of power-oriented checkability and experimental studies showed its increase from 54.3% to 79.7% in case of a decrease of the activity of input

signals from 100% to zero in an 8-bit iterative array multiplier and increase from 37.4% to 82.8 % for a 32-bit multiplier.

Bitwise pipelines demonstrate higher power-oriented checkability, which, under the same conditions, rises from 74.6% to 84.9% and from 69.3% to 89.1%.

Thus, power-oriented checkability significantly complements the possibilities of logical checkability for both traditional matrix circuits and promising bitwise pipelines.

## References

1. Core Knowledge on Instrumentation and Control Systems in Nuclear Power Plants, Technical Reports, IAEA Nuclear energy series no. NP-T-3.12–141 p., International atomic energy agency Vienna (2011).
2. Yastrebenetsky, M. (ed): NPP I&Cs: Problems of Safety, Ukraine, Kyiv: Technika (2004).
3. Palagin, A.V., Opanasenko V.N.: Design and application of the PLD-based reconfigurable devices. In: Adamski, M., Barkalov, A., Wegrzyn M. (eds.) Design of Digital Systems and Devices, Lecture Notes in Electrical Engineering, vol. 79, pp. 59–91. Springer Verlag, Berlin Heidelberg (2011).
4. Yatskiv, V., Yatskiv, N., Jun, S., Sachenko, A., Zhengbing, H.: The use of modified correction code based on residue number system in WSN. In: 7<sup>th</sup> IEEE International Conf. on Intelligent Data Acquisition and Advanced Computing Systems: Technology and Applications, pp. 513–516. Berlin, Germany (2013).
5. Sklyar, V.V., Kharchenko, V.S.: Fault-Tolerant Computer-Aided Control Systems with Multi-version-Threshold Adaptation: Adaptation Methods, Reliability Estimation, and Choice of an Architecture. Automation and Remote Control, vol. 63, no. 6, 991–1003 (2002).
6. Drozd, A., Drozd, M., Martynyuk, O., Kuznietsov, M.: Improving of a Circuit Checkability and Trustworthiness of Data Processing Results in LUT-based FPGA Components of Safety-Related Systems. In: CEUR Workshop Proceedings, vol. 1844, pp. 654–661 (2017).
7. IEC 61508-1:2010. Functional Safety of Electrical / Electronic / Programmable Electronic Safety Related Systems – Part 1: General requirements. Geneva: International Electrotechnical Commission (2010).
8. Bakhmach, E., Kharchenko, V., Siora, A., Sklyar, V., Tokarev, V.: Design and Qualification of I&C Systems on the Basis of FPGA Technologies. In: Proceedings of 7th International Topical Meeting on Nuclear Plant Instrumentation, Control, and Human-Machine Interface Technologies (NPIC&HMIT 2010) , pp. 916–924. Las Vegas, Nevada (2010).
9. Drozd, A., Drozd, M., Antonyuk, V.: Features of Hidden Fault Detection in Pipeline Components of Safety-Related System, CEUR Workshop Proceedings, vol. 1356, pp. 476–485 (2015).
10. Hahanov, V., Litvinova, E., Obrizan, V., Gharibi, W: Embedded method of SoC diagnosis. Elektronika in Elektrotechn, no 8, pp. 3–8 (2008).
11. Drozd, A., Antoshchuk, S., Drozd, J., Zashcholkina, K., Drozd, M., Kuznietsov, N., Al-Dhabi, M., Nikul, V.: Checkable FPGA Design: Energy Consumption, Throughput and Trustworthiness. In book: Green IT Engineering: Social, Business and Industrial Applications, Studies in Systems, Decision and Control, V. Kharchenko, Y. Kondratenko, J. Kacprzyk (eds), vol. 171, pp. 73–94. Berlin, Heidelberg: Springer International Publishing (2018). DOI: 10.1007/978-3-030-00253-4\_4
12. Matrosova, A., Nikolaeva, E., Kudin, D., Singh, V.: PDF testability of the circuits derived by special covering ROBDDs with gates. In: IEEE East-West Design and Test Symposium, EWDTS, pp. 1–5. Rostov-on-Don, Russia (2013).

13. Romankevich, V.A.: Self-testing of multiprocessor systems with regular diagnostic connections. *Automation and Remote Control*, vol. 78, Issue 2, 289–299 (2017).
14. Nicolaidis, M., Zorian, Y.: On-Line Testing for VLSI – A Compendium of Approaches. In: *Journal of Electronic Testing: Theory and Application*, vol. 12, issue 1–2, pp. 7–20 (1998).
15. Abramovichi, M., Stroud, C., Hamilton, C., Wijesuriya, S., Verma, V.: Using roving STARs for on-line testing and diagnosis of FPGAs in fault-tolerant applications. In: *IEEE International Test Conference*, pp. 973–982. Atlantic City, NJ, USA (1999).
16. Gillis, D.: The Apocalypses that Might Have Been. [Online]. Available: <http://www.popmech.ru/go.php?url=http%3A%2F%2Fwww.damninteresting.com%2F%3Fp%3D913>.
17. Department of Energy, DOE Guideline Root Cause Analysis Guidance Document, Office of Nuclear Energy and Office of Nuclear Safety Policy and Standards, Department of Energy, Washington DC, USA, 1992. <http://tis.eh.doe.gov/techstds/standard/nst1004/nst1004.pdf>.
18. Kulanov, V., Kharchenko, V., Perepelitsyn, A.: Parameterized IP Infrastructures for fault-tolerant FPGA-based systems: Development, assessment, case-study. In: *IEEE East-West Design and Test Symposium EWDTS'10*, pp. 322–325. St. Petersburg, Russia (2010). DOI: 10.1109/EWDTS.2010.5742075.
19. Li, H.F.: A structural study of parallel pipelined systems. In: *PhD Dissertation*, Univ. of California., Berkeley (1975).
20. Cadenas, O., Megson, G.: A clocking technique for FPGA pipelined designs. *Journal of System Architecture*, no. 50, 687–696 (2004).
21. Scott J.A., Preckshot G.G., Gallagher J.M. Using Commercial-Off-The-Shelf (COTS) Software in High-Consequence Safety Systems, Lawrence Livermore National Laboratory, UCRL – 122246 (1995).
22. Correia, M., Verissimo, P., Neves, N. F.: The design of a COTS real-time distributed security kernel. In: *Fourth European Dependable Computing Conference*, pp. 234–252. Toulouse, France (2002).
23. Kondratenko, Y., Gordienko, E.: Implementation of the neural networks for adaptive control system on FPGA. In: *Annals of DAAAM for 2012 & 23th Int. DAAAM Symp. "Intelligent Manufacturing and Automation*, vol. 23, no. 1, B. Katalinic (ed), pp. 389–392. DAAAM International, Vienna, Austria (2012).
24. Tyurin, S.F., Grekov, A.V., Gromov, O.A.: The principle of recovery logic FPGA for critical applications by adapting to failures of logic elements. *World Applied Sciences Journal*, 328–332 (2013). DOI: 10.5829/idosi.wasj.2013.26.03.13474.
25. Kharchenko, V., Gorbenko, A., Sklyar, V., Phillips, C.: Green Computing and Communications in Critical Application Domains: Challenges and Solutions. In: *9<sup>th</sup> International Conference on Digital Technologies (DT'2013)*, pp. 191–197. Zhilina, Slovakia (2013).
26. Yakovlev, A.: Energy-modulated computing. In: *Proceedings of Design, Automation and Test in Europe Conference and Exhibition 2011 (DATE 2011)*, pp. 1–6. Grenoble, France (2011).
27. Intel Quartus Prime Standard Edition User Guide: Getting Started, <https://www.intel.com/content/dam/www/programmable/us/en/pdfs/literature/ug/ug-qps-getting-started.pdf>, last accessed 2019/03/20.
28. Drozd, J., Drozd, A., Antoshchuk, S., Kharchenko V.: Natural Development of the Resources in Design and Testing of the Computer Systems and their Components. In: *7th IEEE International Conference on Intelligent Data Acquisition and Advanced Computing Systems: Technology and Applications*, pp. 233–237. Berlin, Germany (2013). DOI: 10.1109/IDAACS.2013.6662656.
29. Palagin, A., Opanasenko, V.: The implementation of extended arithmetic's on FPGA-based structures. In: *9th IEEE International Conference on Intelligent Data Acquisition and Advanced Computing Systems: Technology and Applications*, vol. 2, pp. 1014–1019. Bucharest, Romania (2017). DOI: 10.1109/IDAACS.2017.8095239.

30. Drozd, J., Drozd, A., Antoshchuk, S., Kushnerov, A., Nikul, V.: Effectiveness of Matrix and Pipeline FPGA-Based Arithmetic Components of Safety-Related Systems. In: 8th IEEE International Conference on Intelligent Data Acquisition and Advanced Computing Systems: Technology and Applications. pp. 785–789. Warsaw, Poland (2015), DOI: 10.1109/IDAACS.2015.7341410.
31. Cyclone II Architecture. Cyclone II Device Handbook Version 3.1.—Altera Corporation (2007), [http://www.altera.com/literature/hb/cyc2/cyc2\\_cii51002.pdf](http://www.altera.com/literature/hb/cyc2/cyc2_cii51002.pdf), last accessed 2019/03/20.
32. Drozd, A., Drozd, M., Kuznietsov, M.: Use of Natural LUT Redundancy to Improve Trustworthiness of FPGA Design. In: CEUR Workshop Proceedings, vol. 1614, pp. 322–331 (2016).
33. Park, H.: Truncated Multiplications and Divisions for the Negative Two's Complement Number System. In: Ph.D. Dissertation. The University of Texas at Austin, Austin, USA (2007).
34. Garofalo, V.: Truncated Binary Multipliers with Minimum Mean Square Error: Analytical Characterization, Circuit Implementation and Applications. In: Ph.D. Dissertation. University of Studies of Naples “Federico II”, Naples, Italy (2008).
35. ANSI/IEEE Std 754-1985, IEEE Standard for Binary Floating-Point Arithmetic (1985).
36. IEEE Std 754™-2008 (Revision of IEEE Std 754-1985) IEEE Standard for Floating-Point Arithmetic. IEEE 3 Park Avenue New York, NY 10016–5997, USA (2008).
37. Cyber Physical Computing for IoT-driven Services. Vladimir Hahanov, Eugenia Litvinova, Svetlana Chumachenko. Springer (2017).
38. Maevsky, D., Bojko, A., Maevskaya, E., Vinakov, O., Shapa, L.: Internet of Things: Hierarchy of Smart Systems. In: 9<sup>th</sup> IEEE International Conference on Intelligent Data Acquisition and Advanced Computing Systems: Technology and Applications, vol. 2, pp. 821–827, Bucharest, Romania (2017).
39. Drozd, A., Lobachev, M., Hassonah, W.: Hardware Check of Arithmetic Devices with Abridged Execution of Operations. In: European Design and Test Conf, p. 611. Paris, France (1996) DOI: 10.1109/EDTC.1996.494375.
40. Drozd, A.V., Lobachev, M.V.: Efficient On-line Testing Method for Floating-Point Adder. In: Design, Automation and Test in Europe. Conference and Exhibition 2001 (DATE 2001), pp. 307–311. Munich, Germany (2001). DOI: 10.1109/DATE.2001.915042.
41. Tyurin, S., Kamenskih, A.: Green Logic: Models, Methods, Algorithms. In: Kharchenko V., Kondratenko Y., Kacprzyk J. (eds) Green IT Engineering: Concepts, Models, Complex Systems Architectures. Studies in Systems, Decision and Control, vol 74, pp 69–86, Springer (2017). DOI: [https://doi.org/10.1007/978-3-319-44162-7\\_4](https://doi.org/10.1007/978-3-319-44162-7_4).
42. Drozd, A., Drozd, J., Antoshchuk, S., Antonyuk, V., Zashcholkin, K., Drozd, M., Titomir, O.: Green Experiments with FPGA. In book: Green IT Engineering: Components, Networks and Systems Implementation, V. Kharchenko, Y. Kondratenko, J. Kacprzyk (eds), vol. 105, pp. 219–239. Berlin, Heidelberg: Springer International Publishing (2017). DOI: 10.1007/978-3-319-55595-9\_11.
43. MAX 10 FPGA Development Kit User Guide (2017), <https://www.intel.com/content/dam/www/programmable/us/en/pdfs/literature/ug/ug-max10m50-fpga-dev-kit.pdf>, last accessed 2019/03/20.
44. Intel Quartus Prime Standard Edition User Guide: Power Analysis and Optimization (2018), <https://www.intel.com/content/dam/www/programmable/us/en/pdfs/literature/ug/ug-qps-power.pdf>, last accessed 2019/03/20.
45. Max 10 FPGA Device Architecture (2017), [https://www.intel.com/content/dam/www/programmable/us/en/pdfs/literature/hb/max-10/m10\\_architecture.pdf](https://www.intel.com/content/dam/www/programmable/us/en/pdfs/literature/hb/max-10/m10_architecture.pdf), last accessed 2019/03/20.
46. Intel Quartus Prime Standard Edition User Guide: Timing Analyzer (2018), <https://www.intel.com/content/dam/www/programmable/us/en/pdfs/literature/ug/ug-qps-timing-analyzer.pdf>, last accessed 2019/03/20.

# Discrete-Continuous Stochastic Model of Behavior Algorithm of Surveillance and Target Acquisition System

Oleksandr Shkiliuk <sup>1</sup>, Bohdan Volochiy <sup>2</sup>, Ivan Petliuk <sup>3</sup>

<sup>1,2</sup> Lviv Polytechnic National University, Lviv, Ukraine, 79013

<sup>3</sup> National Army Academy, 32 Heroes of Maidan street, Lviv, Ukraine, 79012

<sup>1</sup>oleksandr.p.shkiliuk@lpnu.ua, <sup>2</sup>bvolochiy@ukr.net

**Abstract.** This paper presents discrete-continuous stochastic model for solving tasks of multivariate analysis of efficiency index and synthesis of functionality indexes of ground surveillance and target acquisition system. Surveillance and target acquisition system consists of passive and active radio electronic subsystems – reconnaissance units. As an efficiency index it is considered the probability of successful execution of task (detection and recognition of an object that is situated on controlled territory) within specified time interval. In the proposed model it is considered such features of the surveillance and target acquisition system as structure of the investigated system, the functionality indexes of its units and functional behavior. For construction of this model the advanced technology for modeling algorithms of information systems behavior was used. This technology represents a researched object by a structural automatic model. Available software tool automates the processes of constructing the graph of states and transitions and formation of an analytic model in the form of system of linear Chapman-Kolmogorov differential equations. The acceptable level of particularization of behavior of the surveillance and target acquisition system is determined only by known information about it. This discrete-continuous stochastic model enables increasing certainty for development of information-driven system for automation of the process of detection and recognition of objects for reconnaissance.

**Keywords:** Behavior Algorithm, Discrete-Continuous Stochastic Model, Structural Automatic Model, Information-Driven System.

## 1 Introduction and task statement

One of the directions for improving the quality of artillery reconnaissance is the creation of new ground surveillance and target acquisition system. Surveillance and target acquisition system (STA) must effectively conduct reconnaissance of the enemy's objects (targets) in conditions of fleeting military actions, dynamic changes of the situations, active electronic counteraction from the enemy's side, and control of artillery fire while performing combat missions.

Nowadays, there are many studies about the performance of separate radio electronic systems, which solve the tasks of ground artillery reconnaissance, e.g. Mobile

Artillery Monitoring Battlefield Radar (MAMBA), Counter Battery Radar (COBRA), Hostile Artillery Location (HALO) and others [1].

Extensive practical experience of National Army Academy officers led to the conclusion that use of separate artillery STA is not sufficiently effective, moreover sometimes, in certain conditions, application is impossible. Relying on this practical experience, three feasible variants for the integration of existing artillery reconnaissance units were proposed, as well as algorithms of the interaction of these units during the task execution.

So, in our case, a complex artillery STA is an object of study. This STA consists of passive and active radio electronic subsystems – reconnaissance units, which differ in their functionality. Passive units are: acoustic (ACU), optical (OPT), optoelectronic (OEC) and infrared (IFR) systems. Active units are radar (RDR) and unmanned aerial vehicle (UAV). The objects (targets) are recognized by the object recognition system (ORS). Thus, the STAs are designed to expose the movable and immovable objects (targets) of the enemy by using contained surveillance systems. The interaction of these systems is provided by an information-driven system (IDS).

Since IDS ensures the successful performance of the STA, the determination of the STA's performance indicators at the stage of the system design before the practical implementation of the STA prototype is very important task. Such task can be solved basing on the model of the STA behavior algorithm. The behavior algorithm (BA) is formal representation of the logic of the information from STA components usage for the performance of the task and consists of a sequence of certain procedures [2]. This algorithm describes the functional interrelations between the elements of the system and the functional behavior of the system in general. Also, behavior algorithm can be used for reliability behavior representing. Behavior algorithm is implemented in the IDS, so it is crucial for the successful functioning of the STA.

As efficiency index of STA, it is considered the probability of successful execution of a task within specified time interval. Under the successful execution of the task, we understand the detection and recognition of an object that is situated on controlled territory. To select a reasonable version of STA it is necessary to obtain a set of tools (models, methods and software) that will provide reliable results during the reasonable time at the stage of system engineering design.

Therefore, the purpose of the article is to present the mathematical model of the complex artillery STA, which will enable to determine the values of the functionality indexes of its units. In this case, the STA would provide the necessary value of the probability of successful execution within acceptable time.

## **2 Overview of the methods of simulation of the behavior algorithms of radio electronic systems**

For the analysis and optimization of structural-algorithmic systems, to which BAs of short-term used STA can be applied, academician V.M. Glushkov proposed the language of algorithmic algebras [3]. Using canonical regular forms of algorithms (linear, disjunctive, iterative and parallel), one can simulate both the external (functionali-



ty) and the internal (reliability) behavior of any structural-algorithmic system. Solving the design tasks and evaluating the reliability of algorithms has been continued in paper [2].

Formalization of logical-probabilistic modeling methods, theoretical and methodological foundations of which were laid down by I.A. Ryabinin [4], are oriented to analysis of reliability and safety, and demands construction of the functional integrity schemes. In paper [5] there is presented the method of automatization of the fault trees construction, that are proceeded from the behavior of a system.

To evaluate the probability of BA successful execution and the average value of its duration, the trajectory modeling method can be used [6]. For this purpose, the graph model of the STA behavior algorithm is used. The BA efficiency indexes can be determined in such model by using the transactional probabilities of alternative transitions and the sequencing of all possible routes passing through the graph from the input node to the output one.

For the analysis of certain systems, Petri nets are used [7], [8]. However, during the simulation with cycles, the decision-making action can put the network into conflict. Therefore, the modeling of behavior using Petri net requires the formation of some sequence of events that will make a conflict between two permitted transitions impossible. The usage of colored Petri nets also did not provide an acceptable result for practical use because of the complication of the cycles description [9].

Attempts to solve the problem of counting cycles for the analysis of the systems behavior were made by using the GO-FLOW-method. While applying this method, there is a significant extension of the GO-FLOW circuit when the number of L signals increases that form  $2^L$  state combinations with increasing number of cycles [10].

The computer simulation methods allow solving the analysis of large systems, including the tasks of evaluation: variants of the system structure, the efficiency of various algorithms of system management or their behavior, the influence of changes in various parameters of the system [11]. However, the development of each simulation model (simulating algorithms) is a separate task that is time-consuming and not flexible, when BA to be modified. Also, this approach does not allow to investigate the behavior of a complex system in each state in particular.

Note, that the article shows that the behavior of the STA is discrete-continuous (it is detailed shown in paragraph 4.1). This circumstance determines the choice of an alternative method for analyzing behavior algorithm method of simulation, namely the state space method, which enables constructing discrete-continuous stochastic models. This model gives information about a research object in the form of probabilities distribution of staying in states for a given value of the duration of certain operation. For the use of the space-state method it is expedient to use the technology of modeling BAs of information systems [12] - [15]. This technology makes it possible to automate the construction of BA that considers the features of short-term radio-electronic systems and enables the synthesis of BAs by multivariate analysis.

The essence of this technology is to present a researched object by using of structural automatic model (SAM), which contains three sets of data: state vector (representing the essence of each state); set of formal parameters (visualizes the structure of the object, the possibilities of procedures, and characterizes event streams), and tree

of the rules for modifying the component of the state vector (displays the object in the selected structure). The structural automatic model formally reproduces the behavior of a complex system and by using special algorithm it allows us to obtain a graph of states and transitions, which is incidental to behavior of researched system.

The available ASNA software tool, which was created on the basis of this technology, allows solving the problem of multivariate analysis of BAs of complex systems. It automates the processes of constructing the graph of states and transitions, and formation of an analytic model in the form of system of linear Chapman-Kolmogorov differential equations, the order of which is determined by the number of states. While using this technology, the engineer is able to choose the necessary extent to consider the processes, occurred in the system. This technology was used in studies [16] and [17]. The acceptable level of particularization of behavior description of the artillery STA is determined only by known information about it.

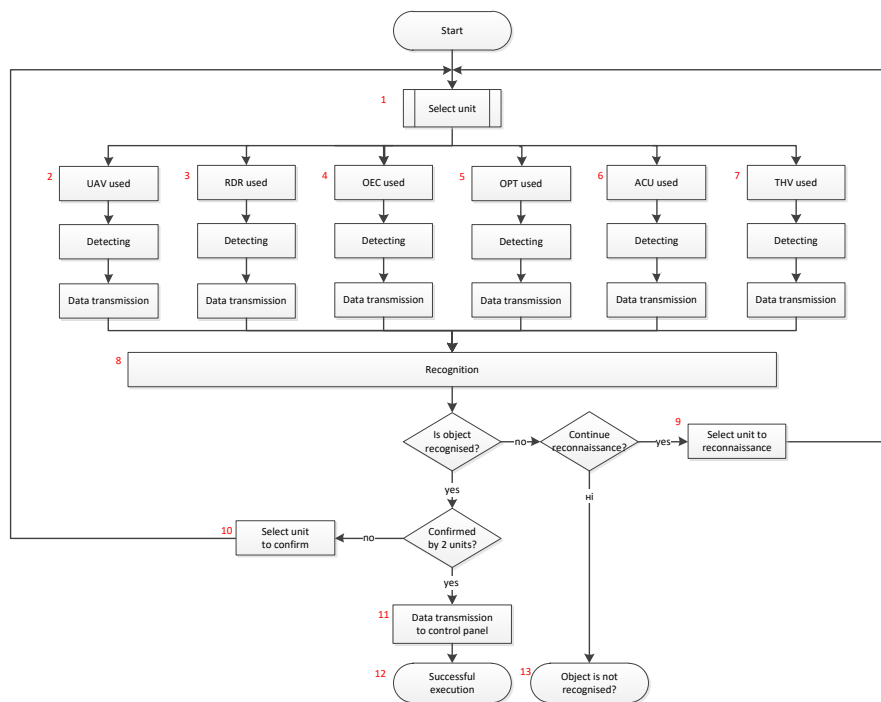
### 3 Behavior algorithm of surveillance and target acquisition system

The development of the STA behavior algorithm is preceded by the analysis of probable variants of the conditions for its application - terrestrial environment monitoring. Table 1 lists the selected STA application conditions and provides recommendations for the integration of methods and tools of reconnaissance. An object (target) is considered to be identified if it is detected and recognized at least by the results of two units of reconnaissance. According to the three variants of STA application conditions, three algorithms for its behavior have been developed. The main requirement for all BA variants is the minimum duration of use of active reconnaissance units.

**Table 1.** Options for the situation in STA will be used and recommendations for the integration of methods and units of reconnaissance.

№	Conditions	Recommendations for units of reconnaissance
1	Conditions are favorable (atmosphere is transparent, visibility is within the limits of permissible norms).	Reconnaissance is carried out by passive units: OPT, OEC, ACU. For short period of time the usage of active units of reconnaissance – radar and UAV are allowed. Priority is given to any of the reconnaissance units.
2	The conditions are medium (the atmosphere is translucent; smoke and fog are possible).	Reconnaissance is carried out by passive units: ACU, IFR. For short period of time the usage of radar is allowed. Priority is given to radar.
3	Conditions are unfavorable (the atmosphere is opaque, poor visibility, rain and snow).	Reconnaissance is carried out mostly by active units (UAV, radar). At the same time, the passive units (ACU, IFR) are available. Priority is given to UAV and radar.

In this article the one of developed algorithms – STA behavior algorithm for favorable conditions is shown (Fig. 1). The STA behavior algorithm consists of 14 operational blocks (one of them is start and two are ends) and three conditional blocks. This BA involves two cycles – to select reconnaissance unit and to select confirmation unit. The STA behavioral algorithm involves the usage of such procedures as: selection of reconnaissance unit, the UAV usage, the radar usage, the OEC usage, the OPT usage, the ACU usage, the IFR usage, detection, data transmission, recognition, results transmission to the control panel, selection of confirmation unit. All three STA behavioral algorithms will be used as the basis for software development for the IDS. The purpose of IDS is to automate the process of the STA task execution.



**Fig. 1.** Flowchart of STA behavior algorithm for favorable conditions.

For the STA behavior algorithm, the input data should be specified. The input data contain the indexes of the functionality for each reconnaissance units and describe the character of their interactions. In accordance with the flowchart of the STA behavior algorithm, we denote the parameters of the operational and conditional blocks as functionality indexes of its components (Table 2).

Used functionality indexes of STA units, namely the probability of object detection, probability of object recognition, average value of the detection time and average value of the recognition time are indexes of their complex efficiency. A posteriori values of these parameters are obtained after their testing and application. The theory of system analysis makes it possible to determine the a priori values of these indexes.

This is very important at the decision-making stage while choosing the principles of STA design.

After the development of algorithms, there is one more task: it is necessary to check whether the value of STA efficiency index will meet the requirements and if the values of the functionality indexes of the units are correctly chosen for it? So, if the received value of the STA efficiency index does not meet the requirements, it is necessary to solve the inverse problem – to determine the values of the functionality indexes of the components, for which the value of the STA efficiency index meet the requirements. It is a statement of the task of analyzing the STA efficiency and the task of synthesizing the functionality indexes of the reconnaissance units, which are part of the STA.

To solve such tasks, it is necessary to have mathematical model of the STA behavior algorithm. The behavior algorithm of STA is corresponded by discrete-continuous stochastic model. For this model construction the advanced technology for modeling algorithms of information systems behavior was used.

**Table 2.** Functionality indexes of the STA components.

Index denotation	Index name
p_ACU	Probability of object detection by acoustic unit
p_UAV	Probability of object detection by UAV
p_OEC	Probability of object detection by optoelectronic unit
p_OPT	Probability of object detection by optical unit
p_RDR	Probability of object detection by radar
p_IFR	Probability of object detection by infrared unit
p_RID	Probability of object recognition by the object recognition system
T_ACU	The average value of the detection time of the object by acoustic unit
T_UAV	The average value of the detection time of the object by UAV
T_OEC	The average value of the detection time of the object by optoelectronic unit
T_OPT	The average value of the detection time of the object by optical unit
T_RDR	The average value of the detection time of the object by radar
T_IFR	The average value of the detection time of the object by infrared unit
T_RID	The average value of the recognition time of the object by object recognition system

The object recognition system compares signatures of objects (targets) received from other reconnaissance units, and proposes decision about the type of object.

## 4 Development of discrete-continuous stochastic model of behavior algorithm of the surveillance and target acquisition system

To develop a discrete-continuous stochastic model of STA behavior algorithm the technology of modeling behavior algorithms of complex systems was used. This technology enables the development of appropriate model with a required degree of adequacy. The high degree of formalization of the technology for developing the graph of state and transmissions, allows to automate partially this process by ASNA software.

### 4.1 Assumptions introduced into the developed model

The first assumption: the change of the STA state depends only on its current state, but does not depend on the previous state. The current state is known, and does not depend on its values at the past moments of time. Thus, the Markov process can be used to simulate a system stochastic behavior that changes its state according to the rules of transitions depending on the current state.

Second assumption: for Markov processes, which are used as a partial case in the space-state method, the exponential law of time distribution between two events is inherent feature. It has predetermined their widespread use at the initial stage of designing systems for the comparative assessment of the reliability of complex technical systems.

Third assumption: it is considered that the ORS does not allow false recognition, that is, an object can either be detected, but not recognized or detected and correctly recognized.

### 4.2 Definition of basic events

To determine the basic events, it is necessary to consider all the processes and procedures that are reflected in the developed STA behavior algorithm (see Fig. 1).

For each procedure, there are proper events that represent their beginning and end. Each procedure is characterized by its average duration. Events that represent the end of the procedure are considered as base events (BE). For the algorithm of STA behavior, basic events are presented in Table. 3.

**Table 3.** Basic events of the behavior of surveillance and target acquisition system.

№	Beginning event	End event	Average duration
BE1	The beginning of the procedure of object detecting by acoustic reconnaissance unit.	The end of the procedure of object detecting by acoustic reconnaissance unit.	T_ACU
BE2	The beginning of the procedure of object detecting by optoelectronic reconnaissance unit.	The end of the procedure of object detecting by optoelectronic reconnaissance unit.	T_OEP
BE3	The beginning of the procedure of object detecting by optical reconnaissance unit.	The end of the procedure of object detecting by optical reconnaissance unit.	T_OPT

№	Beginning event	End event	Average duration
BE4	The beginning of the procedure object recognition by the object recognition system.	The end of the procedure object recognition by the object recognition system.	T_RID
BE5	The beginning of the procedure of object detecting by radar and object recognition.	The end of the procedure of object detecting by radar and object recognition.	T_RDR+T_RID

### 4.3 Assignment of the component of the state vector

Assigned components for the STA state vector, that reflect the current state of the reconnaissance, are shown in Table. 4. For the convenience of reading the symbols of state vector, a semantic representation of the indexes is proposed, which reflects not the conditional number of the component of state vector, but its functional purpose. The appropriate presentation provides the convenience and speed of forming formulas for calculating the intensity of transition from state to state.

**Table 4.** Components of state vector of surveillance and target acquisition system.

Components of state vector	Initial values	Component name
V_ACU	0	Acoustic unit state
V_UAV	0	UAV state
V_OEC	0	Optoelectronic unit state
V_OPT	0	Optical unit state
V_RDR	0	Radar state
V_IFR	0	Infrared unit state
V_USD	0	The current value of the number of used reconnaissance units
V_TLD	0	The current threshold value of the reconnaissance units that detected the object
V_RID	00	Result from object recognition system

The component V\_ACU represents the state of the acoustic reconnaissance unit. This component can take the following values: V\_ACU = 1 – acoustic reconnaissance unit was used, V\_ACU = 0 – the acoustic reconnaissance unit was not used. The initial value of the component is V\_ACU = 0.

Similarly, the components V\_OEP, V\_OPT, V\_RDR represent optoelectronic, optical and radar reconnaissance units respectively.

The component V\_USD represents the current value of the number of used reconnaissance unit. This component can take the following values: V\_USD = [0 .. 4]. The initial value of the component is V\_USD = 0.

The V\_TLD component represents the current value of the number of detected objects used by the reconnaissance units. This component can take the following values: V\_TLD = [0 .. 3]. The initial value of the component is V\_TLD = 0.

The V\_RID component represents the result of object recognizing. This component can take the following values: V\_RID = 0, 11, 12, 13, 21, 22, 23. The initial value of the component V\_RID = 0. V\_RID = 11 – the object is detected by more than one

passive reconnaissance unit and recognized by ORS; V\_RID = 12 – the object is detected by the passive reconnaissance units but not recognized by ORS and needs to be confirmed by the active reconnaissance units; V\_RID = 13 – the object was not detected by passive reconnaissance units; V\_RID = 21 – the object is detected both by passive and active reconnaissance units and recognized by ORS; V\_RID = 22 – the object was detected both by passive and active reconnaissance units, but not recognized by ORS; V\_RID = 23 – the object was not detected by both by passive and active reconnaissance units.

The condition for the successful execution of the STA target function is actual for situation, when the object is detected only by passive or both by passive and active reconnaissance units and recognized by ORS. Formalized representation of the conditions for successful execution of the target function is (V\_RID = 11 or V\_RID = 21).

The condition for the tolerant execution of the STA target function is actual for situation, when the object is detected only by passive or both by passive and active reconnaissance units and but not recognized by ORS. Formalized representation of the condition for the tolerant execution of the target function is (V\_RID = 12 or V\_RID = 22).

The condition for non-successful of the STA target function is actual for situation, when the object is not detected both by passive and active reconnaissance units. Formalized representation of the condition for non-successful of the target function has the following form: V\_RID = 23.

#### 4.4 Development of the base graph of states

The development of the base graph of states was carried out by using the method of constructing graph of states on the basis of basic events. The inputs are: basic events of the STA behavior algorithm, components of the state vector, functionality indexes of the reconnaissance units and recognition system.

The development of the base graph of states is carried out in the following sequence:

Step 1. Form the initial state of the graph, which gives the start of the actual version of the STA behavior algorithm according to the situation for the task execution: [V\_ACU = 0, V\_OEP = 0, V\_OPT = 0, V\_RDR = 0, V\_USD = 0, V\_TLD = 0, V\_RID = 0]. To this state give №1.

Step 2. Consider state №1. Determine if the BE1 is relevant for this state: it is relevant, because the usage of the ACU is provided by the developed behavior algorithm. Note that BE1 generates 2 alternative transitions with the probabilities  $p_{ACU}$  and  $(1-p_{ACU})$  (see Table 2). The first alternative transition represents the continuation of the process, when the object is detected by ACU. This is represented by changing the values of such components of the state vector: V\_ACU = 1, V\_USD = 1, V\_TLD = 1. The state vector [V\_ACU = 1, V\_OEP = 0, V\_OPT = 0, V\_RDR = 0, V\_USD = 1, V\_TLD = 1, V\_RID = 0] is received for the first time. As a result, it will be assigned №2 and the transition from state 1 to state 2 is appointed. Since the intensity of the BE1 is determined by the formula  $1/T_{ACU}$ , the intensity of the transition from state 1 to state 2 in the graph is determined by the formula  $p_{ACU} \cdot (1/T_{ACU})$ . The second alternative transition represents the continuation of the process when the

object is not detected by the ACU. This is displayed by changing the values of such components of the state vector:  $V\_ACU = 1$ ,  $V\_USD = 1$ ,  $V\_TLD = 0$ . The generated state vector [ $V\_ACU = 1$ ,  $V\_OEP = 0$ ,  $V\_OPT = 0$ ,  $V\_RDR = 0$ ,  $V\_USD = 1$ ,  $V\_TLD = 0$ ,  $V\_RID = 0$ ] is also received for the first time. This state is assigned to №3. and the transition from state 1 to state 3 is appointed. The intensity of the transition from state 1 to state 3 is determined by the formula  $1/T\_ACU \cdot (1-p\_ACU)$ .

Steps 3 and 4. Continue to consider state №1. Determine whether the basic events of BE2 and BE3 are relevant for this situation. Yes, they are relevant, because their implementation is provided by the STA behavior algorithm. This means that OEC and OPT can be used. The model parameters for alternative transitions after the basic events of BE2 and BE3 are determined in the same way as after the BE1.

Steps 5 and 6. Continue to consider state №1. Determine if the BE4 and BE5 are relevant for this situation. These events are not relevant for state №1, because the recognition procedures in this state cannot be performed.

Then sequentially examine all the formed states and repeating steps 2, 3, 4, 5, and 6, define new states and graph transitions, and also form formulas for determining the intensities of transitions from state to state.

While developing the graph of states on the basis of basic events, the SAM is verified for the fulfillment of the condition that the sum of the probabilities of alternative transmissions should be equal to 1. In the developed model there is an alternative transmission from basic events for which the given condition is fulfilled.

#### 4.5 Development of structural automatic model of behavior algorithm

During the development of the structural automatic model of the STA behavior algorithm, the following tasks were solved: formal description of situations in which basic events occur; formulas for calculating the intensity of transitions (FCIT) from state to state; the rules for modifying components of the state vector are established (see Table 5).

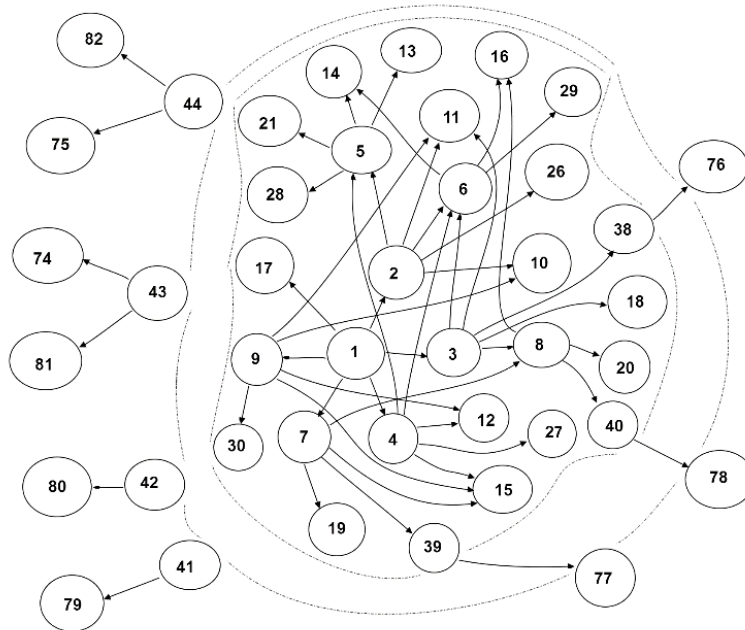
**Table 4.** Structural automatic model of the STA behavior algorithm.

Basic events	Formalized description of the situation	FCIT	Rules for modifying components of the state vector
BE1	$(V\_ACU=0)$ and $(V\_RID=00)$	$p\_ACU/T\_ACU$	$V\_ACU:=1$ ; $V\_USD:=V\_USD+1$ ; $V\_TLD:=V\_TLD+1$
	$(V\_ACU=0)$ and $(V\_RID=00)$	$(1-p\_ACU)/T\_ACU$	$V\_ACU:=1$ ; $V\_USD:=V\_USD+1$
BE2	$(V\_OEC=0)$ and $(V\_RID=00)$	$p\_OEC/T\_OEC$	$V\_OEC:=1$ ; $V\_USD:=V\_USD+1$ ; $V\_TLD:=V\_TLD+1$
	$(V\_OEC=0)$ and $(V\_RID=00)$	$1-p\_OEC/T\_OEC$	$V\_OEC:=1$ ; $V\_USD:=V\_USD+1$
BE3	$(V\_OPT=0)$ and $(V\_RID=00)$	$p\_OPT/T\_OPT$	$V\_OPT:=1$ ; $V\_USD:=V\_USD+1$ ; $V\_TLD:=V\_TLD+1$
	$(V\_OPT=0)$ and $(V\_RID=00)$	$1-p\_OPT/T\_OPT$	$V\_OPT:=1$ ; $V\_USD:=V\_USD+1$
BE4	$(V\_USD>0)$ and $(V\_TLD>1)$ and $(V\_RID=00)$	$p\_RID/T\_RID$	$V\_RID=11$
	$(V\_USD>0)$ and $(V\_TLD>1)$ and $(V\_RID=00)$	$(1-p\_RID)/T\_RID$	$V\_RID=12$



Basic events	Formalized description of the situation	FCIT	Rules for modifying components of the state vector
	$(V\_USD > 0)$ and $(V\_TLD = 1)$ and $(V\_RID = 00)$	$(1 - p\_RID) / T\_RID$	$V\_RID = 12$
	$(V\_USD > 0)$ and $(V\_TLD = 0)$ and $(V\_RID = 00)$	$1 / T\_RID$	$V\_RID = 13$
BE5	$(V\_RDR = 0)$ and $(V\_RID = 12)$	$p\_RDR * p\_RID / T\_RDR$	$V\_RID = 21; V\_RDR = 1; V\_USD = USD + 1; V\_TLD = V\_TLD + 1$
	$(V\_RDR = 0)$ and $(V\_RID = 12)$	$p\_RDR * (1 - p\_RID) / T\_RDR$	$V\_RID = 22; V\_RDR = 1; V\_USD = USD + 1; V\_TLD = V\_TLD + 1$
	$(V\_RDR = 0)$ and $(V\_RID = 12)$	$(1 - p\_RDR) / (T\_RDR + T\_RID)$	$V\_RID = 22; V\_RDR = 1; V\_USD = USD + 1; V\_TLD = V\_TLD + 1$
	$(V\_RDR = 0)$ and $(V\_RID = 13)$	$p\_RDR / (T\_RDR + T\_RID)$	$V\_RID = 22; V\_RDR = 1; V\_USD = USD + 1; V\_TLD = V\_TLD + 1$
	$(V\_RDR = 0)$ and $(V\_RID = 13)$	$(1 - p\_RDR) / (T\_RDR + T\_RID)$	$V\_RID = 23; V\_RDR = 1; V\_USD = USD + 1$

The construction of the states and transitions on the basis of SAM is carried out using ASNA software. The fragment of the received graph of states and transitions for the first behavior algorithm of the STA (in favorable conditions, see Table 1) is shown in Fig. 2.



**Fig. 2.** Fragment of the graph of states and transitions for the behavior algorithm of the surveillance and target acquisition system in favorable conditions.

From the obtained graph of states and transitions, which contains 82 states and 123 transitions, form a mathematical model in the form of system of Chapman-Kolmogorov linear differential equations (1):

$$\begin{aligned} \frac{dP_1(t)}{dt} &= -(\lambda_{1,2} + \lambda_{1,3} + \lambda_{1,4} + \lambda_{1,7} + \lambda_{1,9} + \lambda_{1,17})P_1(t) \\ \frac{dP_2(t)}{dt} &= \lambda_{1,2}P_1(t) - (\lambda_{2,5} + \lambda_{2,6} + \lambda_{2,10} + \lambda_{2,11} + \lambda_{2,26})P_2(t) \\ \frac{dP_3(t)}{dt} &= \lambda_{1,3}P_1(t) - (\lambda_{3,6} + \lambda_{3,8} + \lambda_{3,11} + \lambda_{3,18} + \lambda_{3,38})P_3(t) \\ &\dots\dots\dots \end{aligned} \tag{1}$$

$$\begin{aligned} \frac{dP_{80}(t)}{dt} &= \lambda_{42,80}P_{42}(t) \\ \frac{dP_{81}(t)}{dt} &= \lambda_{43,81}P_{43}(t) \\ \frac{dP_{82}(t)}{dt} &= \lambda_{44,82}P_{44}(t) \end{aligned}$$

where:  $\lambda_{n,m}$  – intensity of transition from the state  $n$  into the state  $m$ ;

$P_i(t)$  – probability of being in the  $i$  state at the  $t$  count of time.

Initial conditions for Chapman-Kolmogorov equation system are (2):

$$\begin{aligned} P_1(0) &= 1 \\ P_2(0) &= 0 \\ &\dots\dots\dots \\ P_{82}(0) &= 0 \end{aligned} \tag{2}$$

The development of SAM is completed after its verification. The verification method of SAM is needed to detect inconsistencies by comparing base graph with graph of states and transitions, constructed using the ASNA software. Detected inconsistencies are pointers of errors in the SAM that need to be corrected.

## 5 Validation of the discrete-continuous stochastic model of the behavior algorithm of the surveillance and target acquisition system

The task of model validation is to check the relevance of qualitative representation of the IDS characteristics by quantitative changing the efficiency index values. This approach is equitable when there are no experimentally determined efficiency index values of the research object. Quantitative changes in the efficiency index were studied with the developed model of the STA behavior algorithm. An efficiency index STA is the probability of its successful execution during the critical duration.

The task of the study was formed to obtain the results, according to which engineer can give a forecast of the efficiency index changing.

Four models of STA construction were used to validate the developed model. They differ in their values of functionality indexes of the STA reconnaissance units (see Table 7).

**Table 7.** Values of functionality indexes of the STA reconnaissance units.

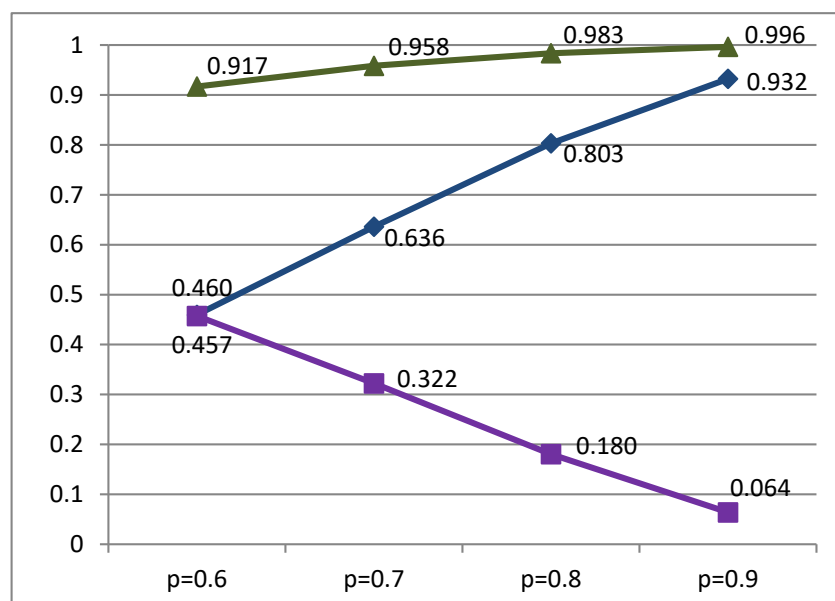
№ of test	Reconnaissance units and their values of functionality indexes – probability of successful detection or recognition of the object				
	ACU	OPT	OEC	RDR	ORS
1	0,6	0,6	0,6	0,6	0,6
2	0,7	0,7	0,7	0,7	0,7
3	0,8	0,8	0,8	0,8	0,8
4	0,9	0,9	0,9	0,9	0,9

For validation of the developed model, two studies were conducted.

**Study 1.** Objectives of the study: to check how the difference between the probabilities of recognition and non-recognition of objects is changing with the growth of the quality of STA reconnaissance units.

The expected result – with increasing of functionality indexes values of STA reconnaissance units, the proportion of recognized objects should increase, that is, the difference between the probabilities of recognition and non-recognition of objects should increase.

Conducted research according to the tasks 1 correspond to the curves in Fig. 3. The study was performed as follows: the curves show the relation between the probabilities of recognition and non-recognition of objects.



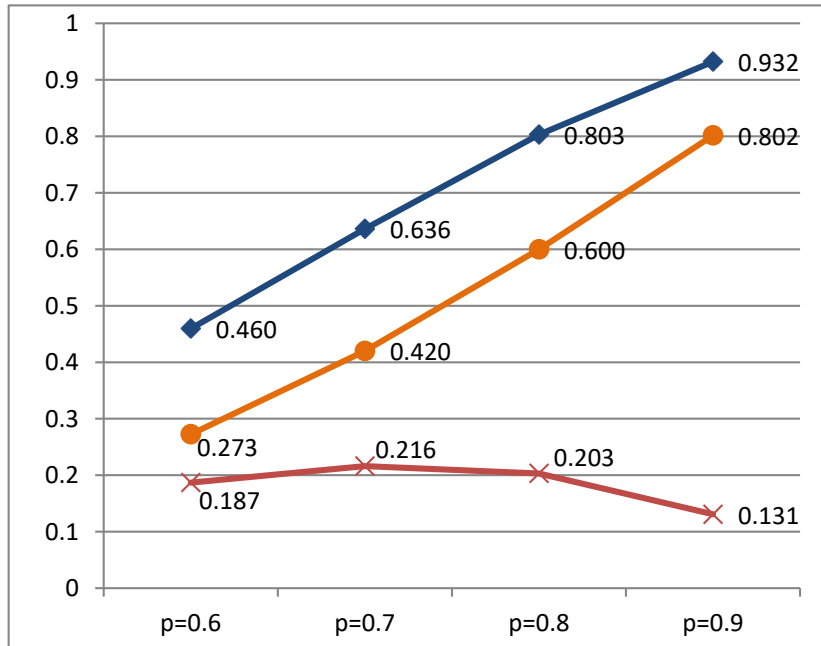
**Fig. 3.** The dependence of the probability of the task execution by STA on the functionality indexes values of reconnaissance units: ▲ – probability of objects detection by passive and active reconnaissance; ◆ – probability of objects recognition by ORS; ■ – probability of objects non-recognition by ORS.

To control the reliability of the results, the dependence of the probability of detecting objects of exploration was investigated. The sum of the probabilities of recognition and non-recognition of objects is equal to the probability of detecting objects, which confirms the certainty of the results. In general, the result of the study coincides with the expected.

**Study 2.** Objectives of the study: check how the relative frequency of the usage of active reconnaissance units with is changing the increasing quality of passive reconnaissance units.

Expected result – with the growth of the quality of passive reconnaissance units, the probability of their successful execution also should increase. At the same time, the relative frequency of implication of active reconnaissance units should decrease. This is explained by the fact that after the task is performed by passive reconnaissance units, the necessary to use active reconnaissance units is decreasing.

The results obtained by study 2 are shown in Fig. 4. Overall, the result of the study confirms the expected.



**Fig. 4.** The dependence of the probability of the task execution by STA on the functionality indexes values of reconnaissance units: ◆ – probability of objects recognition by ORS; ● – probability of objects recognition by ORS after using passive reconnaissance units; × – probability of objects recognition by ORS after using active reconnaissance units.

## 6 Conclusions

The proposed behavior algorithm (in favorable conditions) of the surveillance and target acquisition system, is designed to develop software for information-driven system for automation of the process of detection and recognition of objects.

Having used the improved modeling technique, the discrete-continuous stochastic mathematical model of behavior algorithm of surveillance and target acquisition system was constructed. It considers the structure of the investigated system, its functionality indexes, and the features of functional behavior. This model was used at the structural design stage of the surveillance and target acquisition system. The proposed model of the behavior of the surveillance and target acquisition system provides a solution of task of synthesis of the functionality indexes of this complex through multivariate analysis. The developed model can be used by engineers who design a new artillery surveillance and target acquisition system.

The task of further research will be the development of behavior algorithms of surveillance and target acquisition system for medium and unfavorable conditions and the study of their efficiency as well as considering the incorrect recognition of objects (targets).

## References

1. Gulyás, G.: Ground Surveillance and Target Acquisition System in the Royal Artillery. *AARMS Technology*, Vol. 11 (No. 1), 39–50 (2012).
2. Volochiy, B.: Technique of Construction Models of Behavior Algorithms of Radio Electronic Complex System using the Scheme of Paths Method. *International Journal of Computing*, Vol. 13 (Issue 3), 183–190 (2014).
3. Tseitlin, G. E.: Glushkov Algebras and Clone Theory. *Cybernetics and Systems*, Vol. 39 (Issue 4), 509–516 (2003).
4. Ryabinin, I. A.: Quantitative Examples of Safety Assessment using Logical-Probabilistic methods. *International Journal of Risk Assessment and Management*, Vol. 21 (No.1/2), 4–20 (2018).
5. Rae, A., Lindsay, P.: A Behavior-Based Method for Fault Tree Generation. In: *International System Safety Conference*, pp. 34–41 (2004).
6. Belyaev, V. P.: Estimation of the efficiency of methods of calculating the parameters of connectivity in the structural analysis of radio electronic complexes. *Theoretical Electrical Engineering*, Issue. 54, 8–14 (1998). [in Ukrainian]
7. Peterson, J. L.: *Petri Net Theory and the Modeling of Systems*. Prentice Hall, Englewood Cliffs (1981).
8. Sadou, N.: Reliability Analysis of Discrete Event Dynamic Systems with Petri Nets. *Reliability Engineering and System Safety* 94, 1848–1861 (2009).
9. Bouali, M: Backward Reachability of Colored Petri Nets for Systems Diagnosis. *Reliability Engineering and System Safety* 99, 1–14 (2012).
10. Matsuoka, T.: An Exact Method for Solving Logical Loops in Reliability Analysis. *Reliability Engineering and System Safety* 94, 1282–1288 (2009).

11. Papadopoulos, Y.: Analysis and Synthesis of the Behaviour of Complex Programmable Electronic Systems in Conditions of Failure. *Reliability Engineering and System Safety* 71, 229–247 (2001).
12. Volochiy, B. Yu.: *Modeling Technology of Behavior Algorithms of Information Systems*. Lviv Polytechnic National University Publishing House, Lviv (2004). [in Ukrainian]
13. Dabrowski, C., Hunt, F.: Using Markov Chain and Graph Theory Concepts to Analyze Behavior in Complex Distributed Systems. In: the 23rd European Modeling and Simulation Symposium, pp. 659–668 (2011).
14. Fedasyuk, D., Volochiy, S.: Method of Developing the Behavior Models in Form of States Diagram for Complex Information Systems. In: The X International Scientific and Technical Conference “Computer science and information technologies”, pp. 5–8. Lviv (2015).
15. Fedasyuk, D., Volochiy, S.: Method of Developing the Structural-Automaton Models of Fault-Tolerant Systems. In: The 14th International Conference “The Experience of Designing and Application of CAD Systems in Microelectronics”, pp. 22–26. Polyana (2017).
16. Volochiy, B., Mulyak, O., Kharchenko, V.: Automated Development of the Markovian Chains to Assess the Availability and Performance of Multi-state Multiprocessor System. In: Lisnianski, A., Frenkel, I., Karagrigoriou, A. (eds.) *Recent Advances in Multi-state Systems Reliability. Theory and Applications*, pp. 355 – 373. Springer (2018).
17. Volochiy, B., Yakovyna, V., Mulyak, O., Kharchenko, V.: Availability model of critical nuclear power plant instrumentation and control system with non-exponential software update. In: Bassiliades N., Ermolayev V., Fill H.-G., Yakovyna V., Mayr H.C., Nikitchenko M., Zholtkevych G., Spivakovsky A. (eds.) *Communications in Computer and Information Science*, Vol. 826, pp. 3–20. Springer, Cham (2018).

# Methodology of Defining the Accident Rate Function for Fault Tolerant System with High Responsibility Purpose

Leonid Ozirkovskyy, Bohdan Volochiy, Mykhailo Zmysnyi, Andriy Maschak

Lviv Polytechnic National University, 12 S. Bandera street, Lviv, Ukraine, 79000  
l.ozirkovsky@gmail.com, bvolochiy@ukr.net, zmysnyim@gmail.com,  
himakus@gmail.com

**Abstract.** In this paper we propose a new term - accident rate function. Such term gave a possibility to provide the quantitative assessment for operational safety in the fault tolerant systems with high responsibility purposes.

Moreover, we propose a binary structural automata model. Using the proposed binary structural automata model in the ASNA software, we provide a possibility to build models of the fault tolerant systems in the form of a graph of states and transitions, in an automatic way. Obtained graph of states and transitions is used to define the accident rate function.

The authenticity of the emergency rate function is confirmed by the coincidence of two calculated values. One value is obtained based on accident rate function at determined time interval and the other value is the probability of minimal cut sets obtained based on fault tree at a similar time interval. Using the ASNA software to get the accident rate function and the usage of new methodology of forming the accident rate function from the subarray of non-functioning states makes the process of obtaining the results in an automatic way. As a result, the proposed approach gives a possibility to perform multivariant analysis of functional safety for the systems with high responsibility purpose.

**Keywords:** Safety Analysis, Reliability Model, Fault-Tolerant System.

## 1 Introduction

If the high quality of critical system functioning is required, then the required level of its reliability must be ensured. There are such critical systems as a control system for transport vehicles (aviation, railway, marine transport), a control system with power objects (nuclear, thermal, hydroenergetics), military-oriented systems, medical systems. For such systems, the most determined property is the pre-defined level of functional safety. Functional safety is the property of the system and it determines whether the system or the system submodule fails, and if it does, then the system switches to the state in which there are not any harmful consequences for humans or environment or dependant systems/submodules [1 - 3].

An assesment of functional safety of exploitation of the critical systems is carried

out using the following analyses - Failure Mode, Effects and Criticality Analysis (FMECA), Fault Tree Analysis (FTA) and Even Tree Analysis (ETA). As a result, we obtain the values of the exploitation risk. The proper values are set according to international standards [1, 2, 20]. In case of exceeding maximum legitimate value, it is necessary to provide some corrective actions to decrease it.

For the functional safety, the main value of risk exploitation is a probability of the minimum cut sets (MCS). The minimum cut set is the smallest combination of events called “element failed”, which results in failure of the whole system. If one of the “element failed” events is removed from MCS, the system failure is impossible [4 - 6]. The analysis of MCS gives a possibility to present the most vulnerable elements of the system. As a result, the functional safety of the whole system can increase if the safety of only the most critical (vulnerable) elements of the system expands.

Based on the literature review of functional safety assessment, we may assume that a basic methodology (as an instrument) is a Fault Tree Analysis. The improvements of MCS determination methodology based on FTA are shown in the papers [9, 10, 11, 12, 14]. Methods of time decreasing for MCS determination using FTA, and the methods of calculation probabilities are shown in the publications [7, 8, 13, 15]. It can be seen that in FTA the tree building is the largest and the most time-consuming operation. Therefore, this operation requires a considerable skill from a designer.

The main use of FTA is acceptable only when you need to analyse the functional safety of complex systems only once. But FTA usage is not applicable on the design stage, when it is necessary to execute the functional safety assessment for each proposed variant of the system. The question is about the synthesis of the system with required level of functional safety.

The functional safety assessment, based on the Markov model for the complex system, is shown in the papers [16, 17]. In a monography [16], the approach is developed to obtain the MCS from the graph of the states and transitions. This approach is intended to be used for the analysis of the systems where its model has a large dimension (count with the number of states more than a million). The method of simplification of the graph of the states and transitions was used as a basis for the proposed approach. The simplification has a rule to unite the “similar” states. In the article [17], the approach of safety assessment using the Markov model is presented. As the safety index, the Mean Time Until Failure is used.

Development of the fault tolerant system of the responsibility purpose with the pre-defined level of functional safety on the design stage foresees tackling the task of synthesis of functionality and reliability. Such tasks can be solved with the analysis of many expedient variants of the system. To solve such task, the designer must have a methodology based on which he can determine the functional safety for lots of system variants in a limited interval of time.

## **2 Accident rate function for fault tolerant system**

For the safety assessment of fault-tolerant systems, the MCS are used. The MCS are presented as logical functions [18, 19]. Note that obtained MCS using the fault tree



are point-based and these MCS represent the specific value for the time of operation. For the designer of the fault tolerant system, it is useful to have the dependence of the MCS occurrence probability value and the change of the time of operation. To obtain such a characteristic, many fault trees must be developed, since the fault tree is constructed for given operating time.

Using the model of the fault tolerant system in the form of the graph of the states and transitions opens up the possibility to determine the MCS occurrence probability for any value of the time of operation [22].

The time spent on developing complex system model in the form of the fault tree is comparative to the development of the graph of states and transitions [22]. However, if the building of the state graph is automated [3], then it is possible to determine the MCS occurrence probability, depending (as a function) on the time of operation of the system which is under investigation. We propose to name this function as an "accident rate" function.

Accident rate function (ARF) is dependence on the time of operation (observation), and the probability of the system in the failure state, which leads to an accident. For example, the value of the accident rate is defined as the sum of the probabilities of staying in safe non-functioning states, critical and/or catastrophic states. The transitions between these states show the trajectory of the transition (evolution) of the system from the insignificant failure to failure. Moreover, the less transitions from a failure safe state to a catastrophic one occur, the lower level of the functional safety system has. And therefore, there are fewer opportunities to avoid an accident.

According to the results of the provided research for the accident rate function, the following properties are established:

- 1) For a particular system, the number of accident rate functions  $Q_A(t)$  equals to the minimum cut sets (MCS) for an accident.
- 2) The value of the accident rate function at a specific moment of time is equal to the probability of the appearance of the minimum cut set, which is obtained using the fault tree for the same time period.
- 3) The probability of occurrence of an accident rate situation  $Q_{AC}(t)$  at a given interval of time is determined by the following formula:

$$Q_{AC}(t) = 1 - \prod_{i=1}^k [1 - Q_{Ai}(t)] \quad (1)$$

where  $Q_{Ai}(t)$  – *i*-accident rate function,

$k$  – a number of accident rate functions.

The methodology of determining the accident rate function is shown in the section below.

### **3 Creation of the mask to select the non-functioning states which form the accident rate function**

To get the formula of the accident rate function, we need to define the space of non-functioning states. These non-functioning states cause the accident situation. Because some non-functioning states could be in the different ARF, it is required to

have the means to define their identification. As such means, we propose to use the mask of the accident rate situation.

The accident rate mask is a logical function, formed from the components of the vector states, the transition into a non-functioning state which is necessary and there is a sufficient condition to make the accident situation occur. The accident rate mask is obtained from "Condition of fault of the fault tolerant system fail" by minimizing it under the rules of algebra of logic.

The accident rate mask has the following properties:

If the logical expression, which describes the accident situation, consists of components of the vector states (VS), united only by the operator "AND", then for the research object there is one accidental function:

$$(Vg=0)\wedge(Vh=0)\wedge\dots\wedge(Vk=0)$$

If the logical expression, which describes the accident situation, consists of groups of components united by the operator "OR", and in each of the groups, the VS components are combined only by the operator "AND", then the z-functions of the accident rate are inherent in the object of the investigation:

$$((Vm=0)\wedge(Vn=0)\wedge\dots\wedge(Vq=0))\vee\dots\vee((Vs=0)\wedge(Vt=0)\wedge\dots\wedge(Vy=0))$$

For instance, if as a result of minimization for the "Condition of fault the fault tolerant system fail" the following function was obtained and it consists of three groups of the MCS components which are combined by the OR logical operator:

$$((V1=0)\wedge(V2=0)\wedge(V4=0))\vee((V2=0)\wedge(V5=0))\vee((V1=0)\wedge(V5=0)),$$

then in this case, there are three accident rate functions. The first function of the accident rate is formed by non-functioning states of the system in which the 1st, the 2nd and the 4th modules fail. The second ARF forms non-functioning states of the system, in which the 2nd and the 5th modules fail, and the third one - the non-functioning states of the system in which the 1st and the 5th modules are non-functioning

Based on the obtained masks, using the special algorithm, which is given below, the ARF is formed.

#### **4 Algorithm to form the accident rate functions from the sub Space of Non-Functioning States**

The algorithm of the ARF formation consists of two stages. At the first stage, the groups of all the states are determined based on the mask of an accident rate which correspond to a specific ARF. At the second stage - the expressions are formed to calculate the quantitative value of ARF, from the selected states.

##### **4.1 Stage I: Defining the groups of the states which correspond to each accident rate function**

All the states are selected, in which the VS components correspond to the mask of the accident rate equal to zero. If the mask of the accident rate has several components integrated by the logical OR operator, then there will be ARFs, and there will be the selected group of states for each of them.

The input data for the algorithm is a set of non-functioning states, that are obtained using a binary structural automata model (SAM).

When developing the algorithm for automated determination of ARF, the following assumptions were adopted:

- at least one ARF is inherent to the system;
- a catastrophic state (CS) is the state of the fault system with high responsibility purpose (FSHRP), which creates an accident rate on the object of its (use);
- the accident rate function of the system is determined by a set of states, in which the system enters the path to the fault (accident). If at least one VS component, which is zero, in all these states has given the value of one (to be put into functioning condition), then the creation of an accidental situation will not be due to the FSHRP.

For a compact (algorithmic) description of the developed method, the following abbreviations are used:

**n** – a pointer to the ordinal number of the ARF.

**i, j** - indicators of the ordinal number of the VS components.

**CSC** - a counter for the number of components in an accident rate mask (the number of expressions separated by operators OR).

**ECC** – an external cycle counter.

**ICC** - an internal cycle counter.

**CNCVS** - a constant number of components of the vector state.

**CNC** - a counter of the number of VS components in the accident rate mask.

**ZC<sub>n</sub>** - a zero counter; this counter for ARF, with ordinal number *n* the number of VS components which value equals to zero.

**ARFC** - ARF counter.

**ARMC** - the mask of an accident rate component.

**AARF** - an array of ARFs.

**SE** - a sign of equality.

**SARF** - a sign of ARF.

**V<sub>cn</sub> [i]** - the value of the *i*-th state vector of the mask component of the accident situation with the ordinal number *n*.

To find ARF, it is necessary to sort the obtained array of non-functioning system states on the basis of the smallest number of events which led to the accident rate of the system with the minimum number of VS components equal to zero. They are non-functioning states, in which the transition was made directly from functioning state. As a rule, they are non-functioning safe states. On the basis of the sorted array of non-functioning system states in accordance with the mask component of an accident rate, there are the system states which serve to form the specific ARF. As a result, the array of ARF is obtained.

The first step of this phase is to create a matrix which will consist of three columns – in the first column the ordinal number of the mask of accident rate component is written – *N*, in the second one – VS component is written using comma which

corresponds to the first component of accident rate mask and its value, in the third one – the value of zero counter – especially the number of zeros of VS component in their respective VS (ZC).

#### **ARF sorting procedure**

The sorting procedure is performed in two embedded cycles – external and internal ones – by comparing two adjacent components of the accident rate mask, and involves the execution of the following steps.

The input data:

**ECC** - an external cycle counter which is assigned with the value of a number of components of the accident rate mask.

$$\mathbf{ICC} = (\mathbf{ECC} - \mathbf{1})$$

**n** – a pointer to the ordinal number of mask component of an accident rate.

**(n+1)** – a pointer to the next ordinal number of mask component of an accident rate (of an accident rate)

Step 1. **n=1** is assigned to the pointer to the ordinal number of mask component of an accident rate system; a pointer to the next ordinal number receives the value **(n+1)=2**, the unit is subtracted from the counter of an external cycle **ECC**, **-ECC = ECC-1**; Then you should check the condition whether **ECC** equals to zero:

If **ECC = 0**, it means that the sorting procedure of the mask components of an accident rate is considered to be **completed**. As a result of such procedure, the matrix of mask components of an accident rate is obtained where they are sorted according to the number of VS components which value equals to zero. So, at the beginning the states with the smallest number of VS components which value equals to zero will be introduced.

If **ECC > 0**, it means that the sorting procedure of the mask components of an accident rate continues and it is necessary to proceed to step 2.

Step 2. At this stage the counter of **ZC<sub>n</sub>** zeros with the number **n** is compared to the counter of **ZC<sub>(n+1)</sub>** zeros with the number **(n+1)**.

If the value of the counter of **ZC<sub>n</sub>** zeros with the ordinal number **n** is bigger than the value of the counter of **ZC<sub>(n+1)</sub>** MCS with the ordinal number **(n+1)**, then these VS must be swapped; then it is necessary to reduce the counter of an internal cycle **ICC = ICC - 1** and proceed to step 3.

Note. In the matrix the mask component of an accident rate of ordinal numbers should not be changed, only mask components should be swapped which means to swap VS.

If the value of the zero counter in the mask component of an accident rate **ZC<sub>n</sub>** with the ordinal number **n** is smaller or equals to the value of the zero counter of **ZC<sub>(n+1)</sub>** component with the ordinal number **(n+1)**, which means that these components are not swapped; Then it is necessary to reduce the counter of internal cycle **ICC = ICC-1** and proceed to step 3.

Step 3. At this stage it is necessary to increase the pointer to the ordinal number of

the mask component of an accident rate adding one  $n = n + 1$  and the next pointer to the ordinal mask component  $(n+1) = (n+1) + 1$ . It is also necessary to check whether the value of counter of internal cycles does not equal to zero:

If  $ICC > 0$ , it means that not all adjacent mask components of an accident rate were compared, so it is necessary to proceed to step 2;

If  $ICC = 0$ , it means that all adjacent mask components of an accident rate were compared, so it is necessary to proceed to step 1;

As a result of moving mask components of an accident rate in the matrix, the sorted matrix of these components is obtained. The sorting was based on the value of the number of zeros in MCS. In the first line of the obtained matrix, there will be VS with the smallest number of zeros which corresponds to the mask component of an accident rate. Then there will be the mask component with the same or bigger number of VS components which equals to zero and until all the states are selected, which value of VS components corresponds to the accident rate mask.

#### **Method of determining the accident rate functions**

Method of determining ARF uses the following procedures: to find ARF and to compare the mask component of an accident rate. The process of finding ARF takes place in several embedded cycles – the general cycle of finding ARF and the internal cycles of the comparing procedure of mask components of an accident rate.

The input data:

**CNC** – the value of a number of mask components of an accident rate is assigned;

**ARFC** – zero is assigned to ARF counter  $ARFC = 0$ ;

**j**- pointers to the serial VS component;

**n**- a pointer to the ordinal number of  $CC_n$ ;

**SE** - a sign of equality.

**SARF** - a counter of ARF sign.

Step 1 . The pointer to the ordinal number of mask component of an accident rate obtains the value of the number of components in a mask minus a unit –  $n = CNCVS$  and it is necessary to proceed to step 2.

Step 2. The pointer to the ordinal VS component obtains the first value and the counter of ARF sign obtains the value of the pointer to the ordinal number  $CC - j=1$ ;  $SAFR=n$ . It is necessary to proceed to step 3.

Step 3. At this stage it is necessary to use the comparison procedure of mask comparison of an accident rate (MCAR). The input data will be the following ones: n- the pointer to the ordinal number ON and j – the pointer to the ordinal VS component. After MCAR execution it is necessary to check the sign of equality SE:

If after the MCAR execution the sign of equality will equal to zero  $SE=0$ , it means that the counter of ARF sign should be reduced by one  $SAFR = SAFR - 1$ , and proceed to step 4.

If after the MCAR execution the sign of equality will not equal to zero  $SE \neq 0$ , it is necessary to proceed to step 4.

Having increased the pointer to the ordinal VS component, the next component is selected  $VS - j = j + 1$ ; However, it is necessary to check whether such VS component exists so that such condition is to check:

If  $j > n$ , it is necessary to proceed to step 5.

If  $j \leq n$ , it is necessary to proceed to step 3.

Step 5. This step checks whether the mask component of an accident rate with the ordinal number  $n$  is ARF. It is done by checking the counter of MCS sign which equals to zero or not.

If  $SAFR = 0$ , it means that MCS with the ordinal number  $n$  is the AFR system. The mask component with the ordinal number  $n$  should be written in an array of accident rate functions **AARF**, and increase the counter MCS by a unit  $ARFC = ARFC + 1$ ; then proceed to step 6.

If  $SAFR > 0$ , it is necessary to proceed to step 6.

Step 6.  $n = n - 1$ ;

If  $n > 0$ , it is necessary to go to step 2.

If  $n=0$ , it means that all MCS are checked and all procedures to find ARF were completed and all states of a graph which form the specific ARF were found. The procedure to find ARF is completed.

#### *The procedure of comparing the system states*

The input data:

**CNCVS** – is assigned to the value of the number of VS components;

**ZC<sub>n</sub>** - is assigned to the number of zeros of VS components in a state with the ordinal number  $n$ .

**VS<sub>n</sub> [i]** – the value of  $i$  of VS component that corresponds to the mask component of an accident rate with the ordinal number  $n$ .

**VS<sub>j</sub> [i]** – the value of  $i$  component of the vector state that corresponds to the mask component of an accident rate with the ordinal number  $j$ .

$i = 1$ ;

The input data is also the obtained data from the procedure of finding ARF especially  $n$  and  $j$ .

Step 1. At this stage the relevant VS components are compared to the mask components of an accident rate.

If **BC<sub>n</sub>[i]** component equals to zero (**BC<sub>n</sub>[i] = 0**) and **BC<sub>j</sub>[i]** component also equals to zero (**BC<sub>j</sub>[i] = 0**), it means that  $ZC_n = ZC_n - 1$ ;  $i = i + 1$ ; then it is necessary to proceed to step 2.

If any of the above mentioned conditions is not fulfilled, it means that  $i = i + 1$ ; the it is necessary to proceed to step 2.

Step 2. At this stage the current number of VS component is checked whether it exceeds the total number of VS components of an accident rate in the mask.

If  $i \leq VSC$ , then go back to step 1.

If  $i > VSC$ , then proceed to step 3.

Step 3. At this stage the certain value is attributed to the **SE** comparison sign.

If  $ZC_n = 0$ , so 1 is assigned to SE.

If  $ZC_n > 0$ , so 0 is assigned to SE.

At this stage the comparison procedure of the mask components of an accident rate is completed.

As a result of such procedure, there is the return value of the equality sign **SE** to the procedure which triggered it.

#### 4.2 Stage II: Algorithm for forming expressions for the accident rate functions

At the stage II, it is necessary to create the matrix which consists of four columns – in the first column the ordinal ARF number is written –  $N$ , in the second one – VS component and its value is written, in the third one – the numbers of states are written that form the specific ARF.

The input data:

ARF array obtained at the Stage 1.

An array of all system states (functioning and non-functioning).

**ZC** – the counter of ARF amount that is recorded in the **AARF** array.

**CNCVS** – constant total number of the number of system states.

Step 1.  $j$  is assigned a unit to the pointer of the ordinal ARF number. It means that the first ARF is selected from the array of accident rate functions –  $j=1$ .

Step 2.  $n$  is assigned a unit to the pointer of the ordinal number of a matrix component of an accident rate MCAR. It means that the first MCS is selected from the array of all system states –  $n=1$ .

Step 3. Then it is necessary to use the comparison procedure of matrix components of an accident rate MCAR where  $n$  and  $j$  are the initial data.

If after the MCAR procedure, the equality sign will equal to one **SE = 1**, then in the third column in AARF the state number –  $n$  should be written and proceed to step 4.

If after the MCAR procedure, the equality sign will equal to zero **SE = 0**, then proceed to step 4.

Step 4. The pointer to the ordinal number VSC –  $n$  is increased by one –  $n = n + 1$ ; It is also necessary to check whether the given pointer has exceeded an array of system states. The check is carried out according to the following condition:

If  $n < \text{CNCVS}$ , then the given pointer has not exceeded the array of system states, that is why it is necessary to proceed to step 3.

If  $n \geq \text{CNCVS}$ , then it is necessary to proceed to step 5.

Step 5. The pointer to the ordinal number of matrix component of an accident rate –  $j$  is increased by one  $j = j + 1$ ; It is also necessary to check whether the given counter has exceeded the ARF array. The check is carried out according to the

following condition:

If  $j \leq ZC$ , then the given pointer has not exceeded the array of system states, that is why it is necessary to proceed to step 2.

If  $j > ZC$ , then the procedure of finding states which possess the relevant ARF is completed.

As a result of such procedure, the third AARF column is filled in.

The procedure to obtain the ARF expression is to sum the probability values of staying in relevant states, whose numbers were found in the previous procedure, meaning in states which are written in the third column of the relevant ARF in the matrix of ARF array. As a result, the fourth column is filled with the probability values of relevant ARF. Therefore, the expression of an accident rate function equals to the sum of probabilities in those states that correspond to the accident rate mask.

$$Q_{Ai}(t) = \sum_{j=m}^q P_j(t) + \dots \quad (2)$$

where  $P_j(t)$  – probabilities of MCS stay in a group of non-functioning states  $m \dots q$ , whose value of VS components equals to zero in accordance with  $i$  accident rate mask. The group of non-functioning states in the simplest case can include all the non-functioning states. There can be several groups of such states for MCS.

For example, if the accident rate mask:

$$(Vg=0) \wedge (Vh=0) \wedge (Vk=0)$$

corresponds to such states 20, 21 ... 27 and 32 ... 35, then the ARF expression will have such a look (3):

$$Q_A(t) = \sum_{i=20}^{27} P_i(t) + \sum_{i=32}^{35} P_i(t) \quad (3)$$

## 5 The methodology validation of determining accident rate functions

The methodology validation of determining accident rate functions is carried out by comparing the results obtained from the universal MCS model in a form of a graph of states and transitions using binary structural automata model (SAM) and the results obtained from the fault tree constructed using the software Reliasoft BlockSim [21] for test MCS.

Test MCS without restoration consists of two different modules connected consecutively. Both modules have hot reserve. The first module, which is less reliable, has two reserve modules, while the second one has 1 module. In case of the main module failure, the backup one connects instead of the main one. Means of control and commutation are considered to be absolutely reliable and fast. Therefore, in the most reliable model the probability of successful control and the probability of successful re-



serve module connection equal to one, and duration of these procedures equals to zero. Reserve modules can malfunction regardless of their main ones.

At the first validation stage, the binary structural automata model (SAM) is constructed. A separate component of vector states corresponds to each module. The initial value of each component of vector states equals to 1, since all modules are functioning at the initial moment of time.

The constructed binary structural automata model (SAM) is appointed for ASNA software tool which constructs a graph of states and transitions on its basis. As a result, the graph of states and transitions is obtained which contains 32 states and 111 transitions. The list of states with the value description of each component of vector states is illustrated in Fig. 1.

According to the methodology, the determination of the array of non-functioning states was carried out. The states 1 – 7, 9 – 15, 17 – 23 are functioning. The states 8, 16, 24-32 are non-functioning. Accident rate functions will be formed out of these states.

In order to form accident rate functions in accordance with the developed methodology, it is necessary to form accident rate masks by minimizing the condition of the catastrophic MCS failure:

$$((V1=0) \text{ AND } (V2=0) \text{ AND } (V3=0)) \text{ OR } ((V4=0) \text{ AND } (V5=0))$$

Since the relatively simple fault-tolerant system is chosen in this example, it means that the condition of catastrophic MCS failure does not require minimization and was immediately written as the disjunction of the conjunctions. As a result, there are two operands with the disjunction sign and therefore, there are two accident rate functions.

The first accident rate function has the mask -  $((V1=0) \text{ AND } (V2=0) \text{ AND } (V3=0))$ , and the second one -  $((V4=0) \text{ AND } (V5=0))$ .

So, the first accident rate function will be the sum of probabilities in states where V1, V2 and V3 components equal to zero (4). These states are 8, 16, 24 and 32 (look at Fig.1):

$$Q_1(t) = P_8(t) + P_{16}(t) + P_{24}(t) + P_{32}(t) \quad (4)$$

The second accident rate function will be the sum of probabilities in states where V4 and V5 components equal to zero (5). These states are 24-32 (look at Fig.1):

$$Q_2(t) = P_{25}(t) + P_{26}(t) + P_{27}(t) + P_{28}(t) + P_{29}(t) + P_{30}(t) + P_{31}(t) + P_{32}(t) \quad (5)$$

The Kolmogorov–Chapman system of differential equation was compiled using ASNA software and based on the obtained graph of states and transitions, it was solved and the probabilities division in each state was obtained. The obtained division was exported to Excel spreadsheets and accident rate functions  $Q_1(t)$ ,  $Q_2(t)$  were constructed which are illustrated on Fig.2.

There is also constructed the dependence of probability of accident rate occurrence on time as the sum of probabilities in all non-functioning states (6):

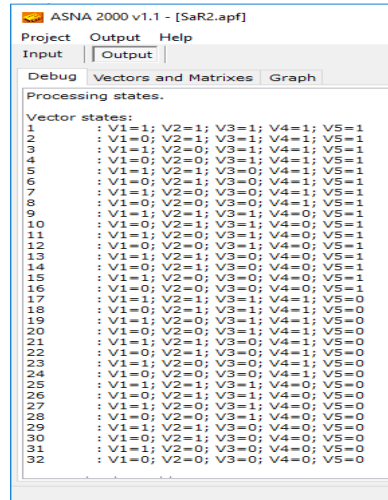


Fig. 1. The list of states with the value description of each component of vector states

$$Q_2(t) = P_8(t) + P_{16}(t) + \sum_{i=25}^{32} P_i(t) \tag{6}$$

and as the sum of accident rate functions (7)  $Q_1(t) + Q_2(t)$  :

$$Q(t) = Q_1(t) + Q_2(t) = 1 - (1 - Q_1(t)) \cdot (1 - Q_2(t)) \tag{7}$$

As it can be seen from Fig.2 the dependencies of both options to calculate the probability of accident rate occurrence coincided.

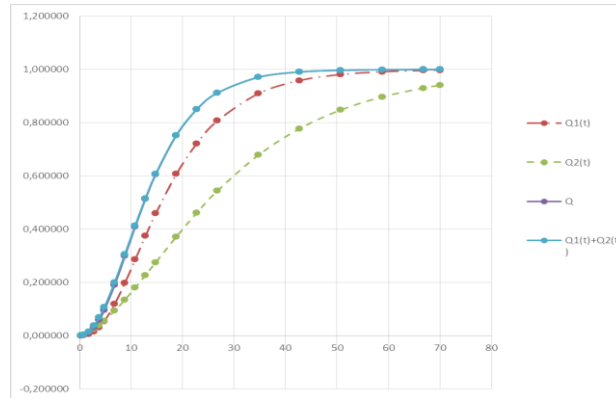
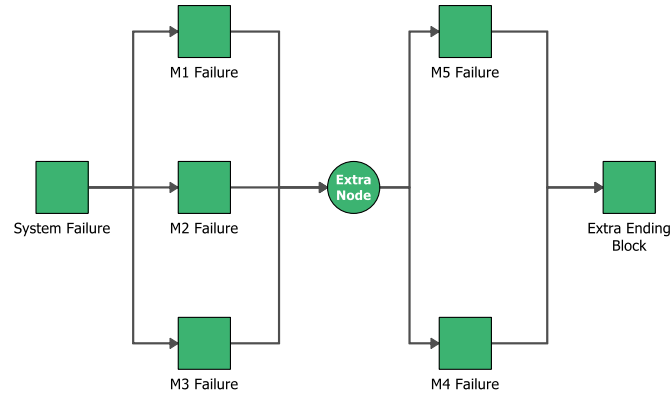


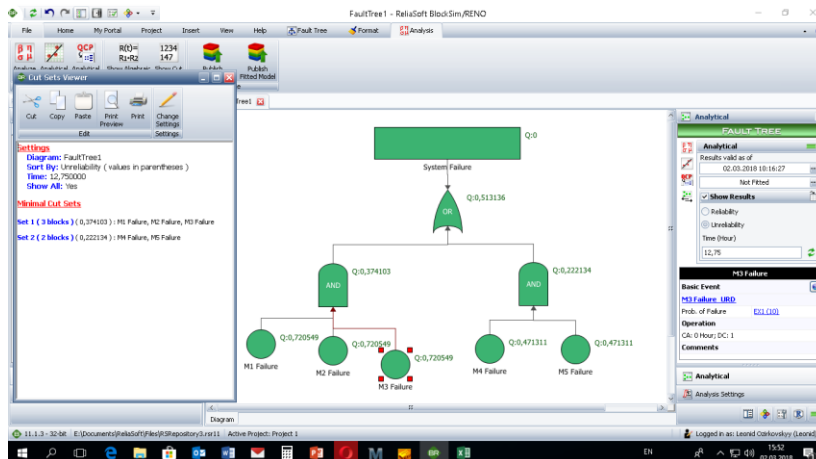
Fig. 2. The accident rate function  $Q_1(t), Q_2(t)$  and the probability of accident rate occurrence  $Q(t)$  – {curve  $Q_1(t) + Q_2(t)$  covered curve  $Q(t)$  }

The structural reliability schema was constructed using the graphical editor of ReliaSoft BlockSim program and is illustrated on Fig.3.

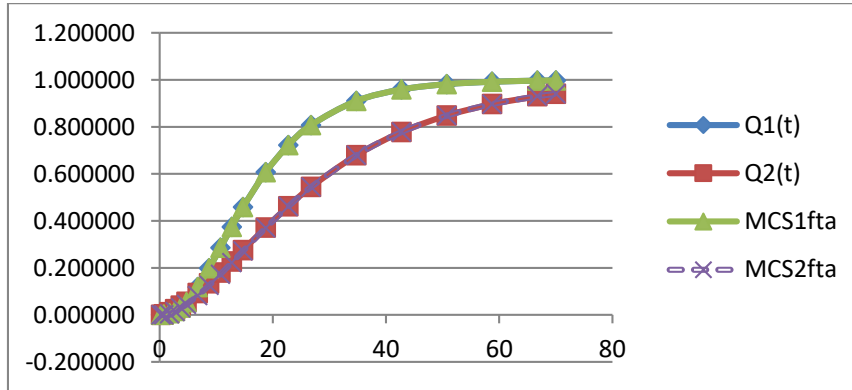


**Fig. 3.** The reliability block diagram obtained in ReliaSoft BlockSim

The next validation stage included the transformation of the structural reliability schema by means of ReliaSoft BlockSim to the fault-tolerant tree which is illustrated on Fig. 4. MCS were found for the fault-tolerant tree by means of ReliaSoft BlockSim, the probabilities of their occurrence were calculated at the same moments of time as well as accident rate functions and the comparison of results was made. As it can be seen from the Fig. 5 the value of the accident rate function  $Q_1(t)$  and the value of probabilities of MCS1fta occurrence completely coincided. Similarly, the value of the accident rate function  $Q_2(t)$  and the value of probabilities of MCS2 FTA occurrence coincided.



**Fig. 4.** The fault-tolerant tree



**Fig. 5.** The value of the accident rate function  $Q_1(t)$  та  $Q_2(t)$  and the value of the probabilities of MCS1fta and MCS2fta occurrence

As a result, it can be concluded that the developed methods and methodology offer reliable results and it is possible to obtain the safety pointer using the graph of states and transitions.

## 6 Conclusions

1. The task of further research will be the development of behavior algorithms of universal reconnaissance complex for medium and unfavorable conditions and the study of their efficiency with considering the incorrect recognition of objects. The term ‘an accident rate function’ was introduced. It allowed to quantify the impact of reliability on safety and vice versa. It is seen that from a reliable model of the system in the form of a graph of states and transitions, it is possible to determine the accident rate function.

2. The confirmation of the accident rate function was provided by comparing two values – the value obtained from the accident rate function, at a determined interval of time with the values obtained from the occurrence probability of the minimum cut set. The minimum cut set was obtained from the fault tree for a similar time interval.

3. The proposed binary structural automata model with ASNA software allows to automate the design of fault-tolerant systems in the form of graphs of states and transitions, which is intended to determine the accident rate function.

4. The usage of ASNA software for the accident rate function and a new method to form accident rate functions from the subspace of the non-functioning states automates this process. Also, it allows a multivariate analysis without excessive time expenditures for the functional safety of the systems with responsible purpose.

## References

1. US Department of Defense Standard Practice for System Safety: MIL-STD-882E, 101p. (2012)
2. US Department of Defense System Safety Program Requirements: MIL-STD-882C.-1993.
3. Bobalo Yu., Volochii B. Mathematical models and methods of reliability analysis of radioelectronic, electrical and software systems. O. Lozinsky, B. Mandzii, L. Ozirkovskii, D. Fedasyuk, S. Scherbovskikh, V. Yakovin. Lviv : Lviv Polytechnic Publishing House, 300 p. (2013). (in Ukrainian)
4. Kececioglu D. Reliability Engineering Handbook, Volume 2. Prentice Hall Inc.: New Jersey, 541 p. (1991).
5. Baldwin E. Carr Unmanned Aerial Vehicles: Examining the Safety, Security, Privacy and Regulatory Issues of Integration into U.S. Airspace. National Center for Policy Analysis, 44 p. (2013).
6. Myers A.: Complex System Reliability. Multichannel Systems with Imperfect Fault Coverage 2nd Edition. Springer-Verlag: London, 238 p. (2010).
7. Jan Krcál, Pavel Krcál Scalable Analysis of Fault Trees with Dynamic Features. 45th Annual IEEE/IFIP International Conference on Dependable Systems and Networks . (2015).
8. Yanbo Che, Yuancheng Zhao, Jianmei Xu, and Jinhuan Zhou / A Hierarchical Approach for Fast Calculating Minimal Cut Sets of a Microgrid. *Mathematical Problems in Engineering*, pp. 1 – 8. (2017).
9. Yuancheng Zhao, Yanbo Che, Tingjun Lin, Chuanyan Wang, Jiaxuan Liu, Jianmei Xu, Jinhuan Zhou Minimal Cut Sets-Based Reliability Evaluation of the More Electric Aircraft Power System // *Mathematical Problems in Engineering*, pp. 1 – 11. (2018).
10. Pang J., Liu Y., Mauw S.: Automatic Generation of Minimal Cut Sets //: 4th International Workshop on Engineering Safety and Security Systems 2015 (ESSS'15) EPTCS 184, pp. 33–47. (2015).
11. Guofeng Tang, Wei Gao Research of the Minimal Cut Sets Post Processing of the PSA Quantification Engine. Nuclear Safety, Security, Non-Proliferation and Cyber Security; Risk Management Shanghai, China, July 2–6, (2017).
12. Zuoyu Miao, Ru Niu : A new generation algorithm of fault tree minimal cut sets and its application in CBTC system. Tao Tang, Jieyu Liu. 2013 IEEE International Conference on Intelligent Rail Transportation Proceedings, pp. 11 - 23. (2013)
13. Woo Sik Jung A method to improve cutset probability calculation in probabilistic safety assessment of nuclear power plants // *Reliability Engineering and System Safety*, Volume 134, February, pp. 134-142. (2015).
14. Francesco Di Maio, Samuele Baronchelli, Enrico Zio Minimal Cut Sets Identification of Nuclear Systems by Evolutionary Algorithms. International Topical Meeting on Probabilistic Safety Assessment and Analysis, Sep 2013, Columbia, United States pp. 1-18 (2013).
15. Kara-Zaitri An improved minimal cut set algorithm // *International Journal of Quality & Reliability Management*, Vol. 13 Issue: 2, pp.114-132 (2013).
16. Dabrowski, C., Hunt, F. and Morrison, K., Improving the Efficiency of Markov Chain Analysis of Complex Distributed Systems. National Institute of Standards and Technology, Interagency Report 7744, 81 p. (2010).

17. Gandhi Satyanarayana, Seetharamaiah P.: Component safety assessment using three-state Markov model. International Research Journal of Engineering and Technology (IRJET), Volume: 02 Issue: 09 | Dec-2015, pp. 299-306. (2015).
18. Vesely, W.E., Dugan, J., Fragola, J., Minarick III, J., Railsback, J.: Fault Tree Handbook with Aerospace Applications. National Aeronautics and Space Administration, August 2002. 218 p. (2002).
19. Eckard Bode, Thomas Peikenkamp : Model Based Importance Analysis for Minimal Cut Sets. Jan Rakow, Samuel Wischmeyer. International Symposium on Automated Technology for Verification and Analysis (ATVA 2008):Automated Technology for Verification and Analysis, 2008, P. 303-317. (2008).
20. US Department of Defense Standard Practice for System Safety: MIL-STD-882D.-2000
21. Block Sim. RBDs, fault trees and Markov diagrams. Режим доступа: <https://www.reliasoft.com/products/reliability-analysis/blocksim>
22. Volochiy B. Yu.: Method of Computation of Minimal Cut Sets of Fault-Tolerant Systems Based on Structural-Automatic Model. B. Yu. Volochiy, L. D. Ozirkovsky, A. V. Mashchak, O. P. Shkiliuk, I. V. Kulyk. Bulletin of National Technical University of Ukraine. Series Radiotechnique. Radioapparatus Building, № 52, pp. 38–45. (in Ukrainian).

# Discrete-Continuous Stochastic Model of Insulin Pump Functioning for Health IoT System Using Erlang Phase Method

Anastasiia Strielkina<sup>1</sup>[0000-0002-7760-7367], Serhiy Volochiy<sup>2</sup>  
and Vyacheslav Kharchenko<sup>1</sup>[0000-0001-5352-077X]

<sup>1</sup> National Aerospace University n.a. Zhukovsky “Kharkiv Aviation Institute”, Kharkiv, Ukraine

<sup>2</sup> Lviv Polytechnic National University, Lviv, Ukraine  
{a.strielkina, v.kharchenko}@csn.khai.edu, volochiy.s@lp.edu.ua

**Abstract.** The presented paper deals with exponentially growing technology – Internet of Things (IoT) in the field of the healthcare and medicine providing. The goal of the paper is to develop and research a discrete-continuous stochastic model (DCSM) of a functional behavior of a networked healthcare device (in this case – an insulin pump) in a form of a structural automaton model (SAM) using the Erlang phase method. It is spoken in the brief details about the networked insulin pump behavior with a description of the functional procedures, indicators and parameters of functionality and safety are given. Much attention is aimed to the development process of the DCSM using exponential and Erlang’s distribution laws, description of basic events and structure of a state vector, development of the SAM’s. The procedures of validation of the developed models for the exponential and Erlang’s distribution laws are presented and include three research cases to check the relevance of the obtained results.

**Keywords:** Discrete-Continuous Stochastic Model, Erlang Distribution, Functional Behavior, Insulin pump, Internet of Things, Structural Automaton Model.

## 1 Introduction

### 1.1 Motivation

Nowadays, Internet of Things (IoT) is an exponentially growing technology throughout the world. About 50 billion devices will be connected to the Internet and the IoT market will reach about \$1.7 trillion by 2020 [1, 2]. IoT systems can be met in any field of humans’ life: sport, education, retail, infrastructure, transport and healthcare. The last one can cause a new scientific revolution within IT and medical fields. According to the statistics of the World Healthcare Organization presented in 2016 [3], about 8.5% of the world population had high blood glucose in 2014. The networked insulin pump can be placed in an inconspicuous place under the patient’s clothes, so a patient can carry out and control the injection of insulin with a special console or

smartphone. According to FDA [4], insulin pump is the most common medical device, and only in 2017, with more than 1.1 million registered cases of medical device malfunctions, about 127.000 are associated with the functioning of insulin pumps.

Safety ensuring of such systems typically involves processes such as defining requirements for system components, threat analysis, risk assessment, analysis of types and consequences of failures, identifying complex interactions between components and scenarios of functional behavior of these components. Complete information on the reaction of components of the critical system is very important, as the behavior of such a system as a whole should be predictable. Such systems are characterized by a high number of failures in the execution of procedures due to the dynamism of influencing factors, and hardware and software malfunctions through multicomponent and multilevel. Therefore, the behavior of the system should be adaptive to both the changing conditions of operation and the failure of the system.

## 1.2 Related Works Analysis

There are some researches describing healthcare IoT systems, the problems and possibilities of their functioning, issues of ensuring functional safety and cybersecurity, etc., and papers related to the modeling of functional behavior of any other systems.

The paper [5] is aimed to investigate the mechanisms for detecting cyber threats in wireless insulin pumps. Moreover, the authors focused on the description of models of anomalous functional behavior of the pump (basal and bolus overdose).

The authors of [6] provided three examples for improving the quality of healthcare IoT systems. One of them is research and ensuring safety at the level of end-use devices (sensors).

The justification for the using of discrete-continuous stochastic processes for the healthcare IoT systems modeling was presented in [7]. Accordingly, in the IoT infrastructure due to the large number of end-use devices and their characteristics, it is assumed that all flows of events are the simplest, and the process occurring in the IoT system is stochastic with discrete states and continuous time. The set of discrete-continuous stochastic models (DCSM) of model's behavior of the healthcare IoT infrastructure for assessing the functional safety and cybersecurity was presented in [8]. In terms of this study is an important the cardinality of a set  $\overline{F = \{S_{F_0}, S_{F_1}, \dots, S_{F_m}\}}$ , only if  $F > 1$  (i.e., the healthcare IoT system has several functional states).

The authors of [9] presented a DCSM of the guard signaling complexes in the form of a structural automaton model (SAM), that describes functional behavior, for using with the software ASNA [10].

All these papers deal with an exponential distribution law. Actuality of researches related to increasing the degree of sufficiency of models of fault-tolerant systems is determined by State standard of Ukraine [11]. It says that exponential distribution, as a one-parameter function, is a crude model for describing durations of fault-tolerant operation, and it gives serious methodical errors in forecasting values of reliability factors. The approach to solving this problem via Erlang distribution law is described in publications by D. R. Koks, V. L. Smit [12, 13], L. Klejnrok [14] etc.



The study of the healthcare functioning systems efficiency in the structure of the Internet of things requires the development of their mathematical models, which take into account the factors listed above. Failure to take account of them can be detrimental to human life. However, the development of such models is a scientific problem to be solved.

### 1.3 Objectives, Approach and Structure of the Paper

In this paper, the aim is to develop a model of the process of functioning of the insulin pump functioning for health IoT system in order to determine the probability of its effectiveness  $P_{r.e.}(t)$ . It should be noted that since the duration of all process procedures in the model will be represented by the exponential distribution law, the resulting value of the efficiency indicator will be limit. And it can be either in an upper or a lower side. Therefore, it is necessary to make a check on which side is the resulting limit value of the efficiency indicator by using the Erlang phase method. The object of research is the insulin pump that operates in the IoT environment. The indicator of the insulin pump using effectiveness is a probability a successful execution of the task (of all necessary procedures occurred in the pump) for the determined time. We differ functionality and reliability related behavior of the device. This paper, first of all, attends to functional behavior considering states when failures are occurred.

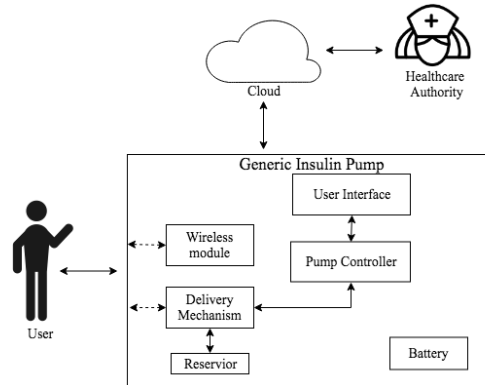
The remainder of the paper is conducted as follows. The section 2 presents a brief description of the insulin pump structure, a sequence of procedures occurring in the insulin pump and indicators and parameters of functionality. The section 3 presents a development process of the DCSM of real states that includes definition of assumptions to the model, description of basic events, development of a SAM and its validation. The section 3 presents a modification of the developed model using the Erlang phase method and its validation followed by conclusion remarks and description of future research directions.

## 2 Analysis of an Insulin Pump Behavior

### 2.1 A Structure of the Insulin Pump

With accordance to [15, 16], Fig. 1 illustrates a generalized structure of the insulin pump that operates in the IoT infrastructure. Respectively, the basic components are:

- End-user (patient), which is the "bearer" of the pump.
- A healthcare organization to which the data are sent and who decides on further treatment of the patient.
- Cloud tools through which communication between the patient and the medical organization occurs.
- The insulin pump consisting of a wireless module for communicating with the patient and the medical device, the controller, the drug reservoir, the injection mechanism, the power supply and the interface for communication with the user.



**Fig. 1.** A list of indicators and parameters of functionality of the insulin pump behavior.

The data from the blood sugar sensor are sent to the blood sugar analysis and insulin requirement computation what is carried out by integrated technical possibilities and tools of the insulin pump and/or sends to the Cloud servers via the Internet gateway for further processing, storage, and visualization [17]. The user interface is necessary for visualizing the processes that take place in the pump both in text and audio form, and to change the settings. The pump controller is required to program the settings for bolus and basal injections in accordance with the prescriptions of the healthcare authority. The delivery mechanism is used to administer insulin to the patient. In turn, the insulin is taken from the reservoir.

## 2.2 Procedures that Form the Pump's Behavior

On the basis of the analysis of the main functions and the principle of the functioning of the insulin pump, a list of procedures that will serve as the basis for determining the basic events necessary for the development of the SAM is formulated: *Procedure 1.* POST – after switching on the insulin pump; *Procedure 2.* Blood analysis test – after successful POST; *Procedure 3.* Data transfer to healthcare authority – after successful blood analysis test, i.e., if the test is not obtained, then the data are not transmitted; after the procedure of injection; *Procedure 4.* Administration set checking – after transferring data to the healthcare authority; there is a check whether the main elements are connected to the pump (injection kit, reservoir, tubes, etc.); *Procedure 5.* Pouring of the pump – after a successful administration set check; *Procedure 6.* Checking the poured pump – after successful pump pouring; *Procedure 7.* Drug existence checking – after successful checking the poured pump; *Procedure 8.* Receiving data from the health authority – after the successful data transferring to the healthcare authority and after successful checking for drugs existence; *Procedure 9.* Drugs conformity checking – after drug existence and data receiving checks, if the data were not received than the drugs are compared with the previous doctor's assignment; *Procedure 10.* Basal dose checking – after successful drug conformity check; *Procedure 11.* Bolus dose checking – after successful drug conformity and basal dose checks; *Pro-*

*cedure 12.* Basal dose concentration checking – after successful basal and bolus doses checks; *Procedure 13.* Bolus dose concentration checking – after successful basal and bolus doses and basal dose volume checks; *Procedure 14.* Basal dose volume checking – after successful basal and bolus doses concentration checks; *Procedure 15.* Bolus dose volume checking – after successful basal and bolus doses concentration and basal dose volume checks; *Procedure 16.* Basal injection speed checking – after successful basal and bolus doses volume checks; *Procedure 17.* Bolus injection speed checking – after successful basal and bolus doses volume and basal speed injection checks; *Procedure 18.* Settings changing (recovery) – after not successful basal and bolus injection settings checks. *Procedure 19.* Basal injection – after successful off all injection settings checks; *Procedure 20.* Bolus injection – during basal injection; *Procedure 21.* Reservoir checking – during basal and bolus injection; *Procedure 22.* Switching off the device – after successful completion of all procedures or after a critical refusal due to non-execution of a certain procedure.

Each procedure ends either successfully or not.

### 2.3 Functional Parameters and Indicators of the Pump's Behavior Procedures

During developing of the model of functional behavior of the insulin pump, its composition and separate components should be described using the corresponding indicators and parameters of functionality, namely: the planned number of possible (repeated) POST's – 2; probability of successful POST –  $P_{sst}$ , blood analysis test –  $P_{ao}$ , data transferring –  $P_{dt}$ , administration set availability and operability capacity checking –  $P_{ce}$ , pouring the pump –  $P_{pp}$ , the poured pump checking –  $P_{cp}$ , drug existence checking –  $P_{dc}$ , receiving data from the healthcare authority –  $P_{da}$ , drugs conformity checking –  $P_{cd}$ , basal dose checking –  $P_{bd}$ , bolus dose checking –  $P_{bld}$ , basal dose concentration checking –  $P_{bc}$ , bolus dose concentration checking –  $P_{blc}$ , basal dose volume checking –  $P_{bv}$ , bolus dose volume checking –  $P_{blv}$ , basal injection speed checking –  $P_{bs}$ , bolus injection speed checking –  $P_{bls}$ , changing of settings (recovery) –  $P_{rs}$ , basal injection –  $P_{in}$ , reservoir fullness during injection –  $P_{rc}$ , bolus injection –  $P_{bl}$ , switching off the device –  $P_{su}$ ; average duration of POST –  $T_{s.t}$ , switching off the device –  $T_{p.d}$ , blood analysis test –  $T_{b.a}$ , data transferring to healthcare authority –  $T_{d.t}$ , administration set availability and operability capacity checking –  $T_{c.e}$ , checking of the poured pump –  $T_{c.p}$ , pouring the pump –  $T_{p.p}$ , drug existence checking –  $T_{d.e}$ , receiving data from the healthcare authority –  $T_{d.a}$ , drugs conformity checking –  $T_{c.d}$ , basal dose checking –  $T_{b.d}$ , bolus dose checking –  $T_{bl.d}$ , basal dose concentration checking –  $T_{b.c}$ , bolus dose concentration checking –  $T_{bl.c}$ , basal dose volume checking –  $T_{b.v}$ , bolus dose volume checking –  $T_{bl.v}$ , basal injection speed checking –  $T_{b.s}$ , bolus injection speed checking –  $T_{bl.s}$ , changing of settings (recovery) –  $T_{r.c}$ , basal injection –  $T_{in}$ , bolus injection –  $T_{bl}$ , reservoir fullness during injection checking –  $T_{rc}$ .

Average durations of each procedure are taken from the technical specifications of insulin pump manufacturers. In fact, performing of each procedure in the fault-tolerant systems (in this case, in healthcare systems) is not absolutely successful, the probability of the successful completion of any procedure is  $P < 1$ .

### 3 Development of Discrete-Continuous Stochastic Model of Real States

Development of the discrete-continuous stochastic model (DCSM) is performed in accordance with the methodologies described in [18]. This methodology involves: determining the basic events of the functional behavior of the research object; compiling a list of indicators and parameters of functionality (Section 2.3), which should be taken into account in the DCSM; forming a state vector (assigning a component to the state vector in accordance with the requirements for the adequacy degree of the model); developing a reference graph of states; developing of a structural automaton model (SAM), including its verification; validation of DCSM. In more details the process of DCSM development of the insulin pump functional behavior was described in [19].

#### 3.1 Assumptions to the Model Development

During the development of the DCSM several assumptions and the hypothesis were made:

- Procedures 1, 2, 5, 7, 9-18, 22 have the fixed durations; however, in the developed model, these procedures are presented as continuous random variables with an exponential distribution law; and the values of these durations are taken as average values of random variables.
- Duration of procedures 3, 4, 6, 8, 19-21 are continuous random variables; and the values of these durations are taken as average values of random variables; since the real distribution laws for the durations of these procedures are currently unknown, then during the development of the model adopted the traditional hypothesis of the exponential distribution law. Note that the results of the model's analysis with such hypotheses have a limit value [20].
- Taken into account that the durations of the procedures have different values - hours, minutes, seconds; therefore, the model assumes that the duration of the procedure 22 (under the condition of critical failure) in a few seconds is equal to 0.
- Procedures 19, 20, 21 in reality occur in parallel; the model used assumptions about their consistent execution. Since the average duration of procedures 20 is much less than the average duration of the procedure 19, and the average duration of the procedure 21 is equal to the procedure 19, their values are taken to be 0.
- The probability of performing procedure 22 is equal 1.

The substantiation of the hypotheses and assumptions clarifies the information on the degree of the developed model adequacy.

#### 3.2 Definition of Basic Events

During the SAM development it is necessary to take into account all the procedures and processes that occur during the operation of the insulin pump. Procedures are characterized by events beginning (BP), ending and average duration values. End-of-

procedure (EP) events are accepted for basic events (BE). Non-compliance events, as well as procedures with an average duration value of 0, are presented as coincident base events (CBE). For the system under study, a description of the events has been made, in accordance with the list of procedures in Section 2.2, which are: *BE1*: EP the first POST; *CBE2*: EP switching off; *BE3*: EP the second POST; *BE4*: EP blood analysis test; *BE5*: EP data transferring to the healthcare authority; *BE6*: EP administration set checking; *BE7*: EP the pump pouring; *BE8*: EP the poured pump checking; *CBE9*: EP switching off; *BE10*: EP drug existence checking; *BE11*: EP data from the healthcare authority receiving; *BE12*: EP drugs conformity checking; *CBE13*: EP switching off; *BE14*: EP basal dose checking; *CBE15*: EP switching off; *BE16*: EP bolus dose checking; *CBE17*: EP switching off; *BE18*: EP basal dose concentration checking; *CBE19*: EP switching off; *BE20*: EP bolus dose concentration checking; *CBE21*: EP switching off; *BE22*: EP basal dose volume checking; *CBE23*: EP switching off; *BE24*: EP bolus dose volume checking; *CBE25*: EP switching off; *BE26*: EP basal injection speed checking; *CBE27*: EP switching off; *BE28*: EP bolus injection speed checking; *CBE29*: EP switching off; *BE30*: EP settings changing (recovery); *BE31*: EP basal injection; *CBE32*: EP bolus injection; *CBE33*: EP reservoir fullness checking during injection; *CBE34*: EP injection ending; *BE35*: EP data transferring of injections results to the healthcare authority; *BE36*: EP switching off.

It should be noted that the coincident base events *CBE15*, *CBE17*, *CBE19*, *CBE21*, *CBE23*, *CBE25*, *CBE27* and *CBE29* occur only when the model does not provide recovery procedures.

### 3.3 Structural Automaton Model Development

The initial data for developing of a reference graph are: basic events (BE), indicators and parameters of functionality, state vector. The technique of its development was described in [18]. The fragment of list of indicators and parameters of functionality of the insulin pump behavior is shown in Fig. 2.

Name	Value	Info
Psst	0.95	Probability of successful POST
Ppa	0.95	Probability of blood analysis taking
Pdt	0.95	Probability of successful data transferring to a healthcare authority
Pce	0.95	Probability of successful checking of administration set
Ppp	0.95	Probability of successful check prime
Pcp	0.95	Probability of successful check prime of pump (with pouring)
Pdc	0.95	Probability of successful checking of drug existence
Pda	0.95	Probability of successful receiving of doctor asgmt
Pcd	0.95	Probability of successful receiving of drugs conformity
Pbd	0.95	Probability of successful basal dose checking
Pbc	0.95	Probability of successful basal concentration checking
Pbdc	0.95	Probability of successful bolus concentration checking
Pbv	0.95	Probability of successful basal volume checking
Pbv	0.05	Probability of successful bolus volume checking

Fig. 2. A list of indicators and parameters of functionality of the insulin pump behavior.

The initial value state vector of functional behavior model of the insulin pump using is represented in Fig. 3. Formalized representation of the conditions for a successful execution of the task has the following form ( $V6 = 0$ ). The full description of the state vector values was presented in [19].

Name	Value	Info
V1	0	state of POST
V2	0	state of connection with a healthcare authority
V3	0	blood analysis
V4	0	pump elements operability
V5	0	drug info
V6	1	device state
V7	0	basal injection settings
V8	0	bolus injection settings
V9	0	doctor asgmt
V10	0	reservoir filling

\* Name (Auto: Vn): \* Value: Info: Add Insert Replace

\* Refuse Expression:  
(V6=0)

Fig. 3. The initial value of the state vector and the condition of successful execution of the task.

Formalized representation of the object of investigation in the form of SAM using software ASNA is show in Fig. 4.

Event	Condition	Formula	Alternati...	Modification
BE1	(V1=0) AND (V6=1)	Past*(1/Ts.t.)	1	V1:=1
	(V1=0) AND (V6=1)	(1-Past)*(1/Tp...	1	V1:=2; V6:=3
BE3	(V1=2) AND (V6=3)	Past*(1/Ts.t.)	1	V1:=3; V6:=1
	(V1=2) AND (V6=3)	(1-Past)*(1/Tp...	1	V1:=4; V6:=2
BE4	((V1=1) OR (V1=3)) AND (V3...	Pao*(1/Tb.a.)	1	V3:=1
	((V1=1) OR (V1=3)) AND (V3...	(1-Pao)*(1/Tb...	1	V3:=2
BE5	((V1=1) OR (V1=3)) AND (V2...	Pdt*(1/Td.t.)	1	V2:=1
	((V1=1) OR (V1=3)) AND (V2...	(1-Pdt)*(1/Td.t.)	1	V2:=2; V9:=2
BE6	((V1=1) OR (V1=3)) AND ((V...	Pce*(1/Tc.e.)	1	V4:=1
	((V1=1) OR (V1=3)) AND ((V...	(1-Pce)*(1/Tp.d.)	1	V4:=2; V6:=2
BE7				

\* Event: \* Condition: \* Formula: \* Alternative: Add Insert Replace

\* Modification: Info:

Fig. 4. The SAM of functional behavior of the insulin pump.

After development of SAM it is necessary to verify it to be sure that developed model using software ASNA constructs the graph of states and transitions correctly. In this paper the verification was conducted using testing graph of states and transitions, whose function is performed by the reference graph of states. The DCSM of functional behavior of insulin pump is presented in the form of the graph of states and transitions and has the following parameters: 209 states and 553 transitions for the system without recoveries i 466 states and 872 transitions for the system with recoveries.

### 3.4 Validation of the Developed Model

The aim of validation procedure is to check the relevance of a qualitative representation of the change nature in the value of the performance indicator, which has the developer of the model, with the dependencies obtained using the developed DCSM. Two models have been developed: the first model does not take into account the procedure of recovery the device's operability, and in the second one it is taken into account.

**Task 1 for Validation.** It is necessary to check whether the nature of the dependency depends on the probability of not performing the task in the interval from zero to the end of its decline.

**Initial Values.** The calculations are performed for the following *initial values* of indicators: probabilities of successful execution of procedures have next values:  $P_{r.e.} = 0.99999; 0.95; 0.9$ .

**Expected Results.** Dependence begins with the probability of not performing the task is equal to 1. This value should be kept for some time. This time defines the total duration of execution of all procedures, which corresponds to the condition in which the task can be performed. It was taken into account that the duration of all procedures is fixed, and the random nature of the process determines the probability of a successful execution of each of the procedures. Since the developed model assumes that the duration of procedures is random variables with exponential distribution law, the average value of which is equal to the duration of the procedure, it is important that the nature of the dependence is close to real. That is, the decline of dependence should begin after reaching the observation time for the total duration of all procedures.

**Obtained Results.** The obtained results of models 1 and 2 presented in Fig. 5. The conducted research on tasks 1 and 2 corresponds to curves 1, 3, 5 and 2, 4, 6, respectively. The research on task 3 corresponds to curves 1 and 2 for  $P_{r.e.} = 0.99999$ , curves 3 and 4 for  $P_{r.e.} = 0.95$ , curves 5 and 6 for  $P_{r.e.} = 0.9$ . The duration of successful completion of all procedures is 4200 seconds. Dependence of the not execution of the task begins with 500 seconds.

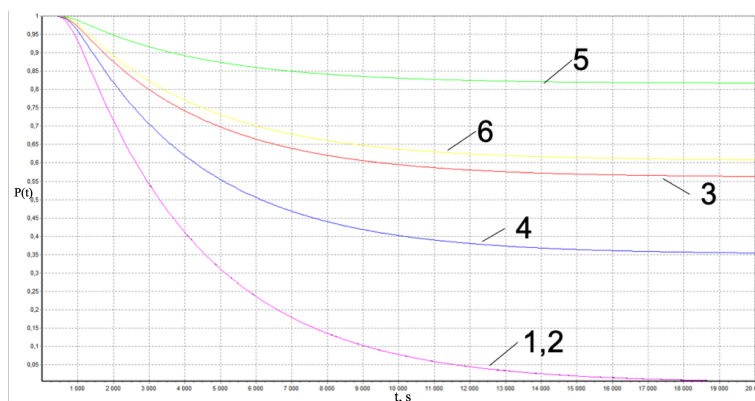


Fig. 5. The obtained results for the research case 1.

**Conclusion on Task 1.** The nature of the dependence on the above interval of time does not correspond to the expected. Therefore, it is proposed to improve the DCSM with the aim of replacing the exponential distribution law with the Erlang distribution law. This improvement is realized by modification of the SAM. The method of modification is presented in [21].

The ASNA software solves the system linear homogeneous differential equations, which is presented in the form of probabilities of staying in the states. If, for the obtained graph of states and transitions, a system of linear homogeneous differential Kolmogorov-Chapman equations is formed, then the determined value of the efficiency indicator is bounded. This is due to the fact that the Kolmogorov-Chapman equations represent the duration of procedures by the exponential distribution law. However, this value may be upper or lower boundary. To answer this question, it is needed to have a model in which all or some of the duration of the procedures will be presented by another distribution law.

#### **4 Development of the Insulin Pump Functional Behavior Model Using the Erlang Phase Method**

The Section 3 shows the developed insulin pump behavior model, in which the duration of all procedures is represented by an exponential distribution law. This model yields an indicator of efficiency. However, this value may be upper bound or lower boundary. To solve this issue, it is needed to create a model of insulin pump functional behavior, in which part of the procedures will be presented by the Erlang distribution law.

The choice of procedures and their number should be such as to see the difference between the value of the efficiency indicator obtained when using the Erlang distribution law for the duration of a certain part of the procedures model and the value of the efficiency indicator obtained when using in the model of the exponential distribution law for the duration of all procedures.

A noticeable difference between the values of efficiency indicators gives the representation of the duration of the first, second, third and fifth insulin pump procedures according to the Erlang distribution law.

The method of using the Erlang distribution law in discrete-continuous stochastic behavior models is described in [21], based on the method of stages [14]. According to this method, it is enough to modify the components of the SAM to develop the model. To do this, it is necessary for each selected procedure to form a chain of fictitious states that differ in the number of states and formulas for determining the intensity of transitions from state to state.

##### **4.1 Modification of the SAM Using the Erlang Phase Method**

Each of the selected procedures gives an alternative continuation of the process, when presented in the state graph. For each alternative continuation of the process, a chain of fictitious states is formed, despite the fact that these chains should be exactly the



same. If there are two alternatives, then two symbols for the order of the Erlang distribution law - E1 and E2 are introduced to the list of indicators of functionality and parameters. If there are three alternatives, then three symbols E1, E2 and E3 are introduced etc.

To form each chain, the state vector is introduced with its own component, called "The current value of the fictitious transition to the chain of the first (second, third, etc.) alternative". The initial value for each component is zero.

#### 4.2 Additional Components in the State Vector

The number of additional components of the state vector is determined by the number of alternative process extensions that arise at the time the completion of each separate task is completed. Duration of each separate task should be submitted according to the Erlang distribution law of the appropriate order. Because each separate task has alternate extensions, two additional components are added to the model in the state vector V11 and V12, which are required to display the current value of the fictitious transition for each chain in the procedure.

The initial values are V11=0 and V12=0 that means that the object of research in the model is represented by the real state. The current component value varies from 1 to E, where E is the order of the Erlang distribution law for the procedure, that is, the number of fictitious states in the chain.

#### 4.3 Changes in the SAM Components

In accordance with the above procedures, it is necessary to identify the components of the CAM that need to be modified that should be changed. Each procedure corresponds to a certain base event and one or more situations in which it occurs. Making changes to the SAM is as follows.

The logical expression of each alternative, where a certain BE occurs, is supplemented by additional three logical expressions that form fictitious states.

**Logical Expression 1.** This expression is needed to identify the current state and initiate the formation of a chain of fictitious states. Modification of this expression is as follows. The components ( $E > 1$ ) are introduced to recognize that the order of the Erlang distribution law is greater than 1 (the exponential law is not used); for the first and second alternatives, the logical expressions have the following form:

$$(V11 = 0) \text{ AND } (V12 = 0).$$

The formula for calculating transition intensity (FCTI) is supplemented by the factor E for the invariance of the average value of the duration of the procedure when the order of the Erlang distribution law E [14]. The rules of component modification of state vector (RCMSV) for the first and second alternatives are: V11:=1 and V12:=1 accordingly.

**Logical Expression 2.** This expression is necessary to initiate the formation of the following fictitious states of the chain (except the last). Modification of this expression is as follows. The components ( $E > 1$ ) are introduced to recognize that the order

of the Erlang distribution law is greater than 1 (the exponential law is not used); for the first and second alternatives, the logical expressions have the following form:

$((V11 > 0) \text{ AND } (V11 < (E-1))) \text{ AND } (V12 = 0) \text{ i } (V11 = 0) \text{ AND } ((V12 > 0) \text{ AND } (V12 < (E-1)))$ .

The FCTI is the same as for the logical expression 1. The RCMSV for the first and second alternatives are:  $V11 := V11 + 1$  and  $V12 := V12 + 1$  accordingly.

**Logical Expression 3.** This expression is necessary to initiate the formation of the last states of the chain of fictitious states, that is, the transition to the corresponding real state. Modification of this expression is as follows. The components ( $E > 1$ ) are introduced to recognize that the order of the Erlang distribution law is greater than 1 (the exponential law is not used); for the first and second alternatives, the logical expressions have the following form:

$(V11 = (E-1)) \text{ AND } (V12 = 0) \text{ i } (V11 = 0) \text{ AND } (V12 = (E-1))$ .

The FCTI is the same as for the logical expressions 1 and 2. The RCMSV for the first and second alternatives are:  $V11 := 0$  and  $V12 := 0$  accordingly.

A fragment of the results of amending to the SAM is presented in Table 1.

Based on the results of the changes, the SAM is introduced into the ASNA software, which generates a graph of states and transitions.

In order to make sure that the modified SAM is built correctly, it should also be verified. The data in Table 2 should be used to validate models before using them.

#### 4.4 Validation of the Changed Model

The aim of validation procedure is to check the relevance of a qualitative representation of the change nature in the value of the performance indicator, which has the developer of the model, with the dependencies obtained using the modified DCSM. Two models have been developed: there are assumptions about the exponential distribution law in the first model and the Erlang distribution law of the given order in the second model.

**Task 2 for Validation.** It is necessary to determine what is the limiting value of the task non-performing probability for a model with an exponential distribution law - upper or lower.

**Initial Values.** The calculations are performed for the following initial values of indicators and parameters: probabilities of successful execution of all procedures have next values:  $P_{r.e.} = 0.95$ ; the orders of the Erlang distribution law  $E - 1$  (exponential law); 2; 5; 10.

**Expected Results.** For the research case 2, the limiting value of the task non-performing probability under the exponential distribution law is lower.

**Obtained Results.** The obtained results in the form of dependencies of the research case 2 for the Erlang distribution law of the different orders (in this study,  $E = 1, 2, 5, 10$ ) are presented in Fig. 6.

**Table 1.** The updated SAM fragment using the Erlang phase method.

BE	Description of situations where basic events occur	FCTI	RCMSV	
BE1	(E=1) AND (V1=0)	Psst*(1/Ts.t.)	V1:=1	
	(E=1) AND (V1=0)	(1-Psst)*(1/Ts.t.)	V1:=2; V6:=3	
	(E>1) AND (V1=0) AND (V11=0) AND (V12=0)	E*Psst*(1/Ts.t.)	V11:=1	
	(E>1) AND (V1=0) AND ((V11>0) AND (V11<(E-1))) AND (V12=0)	E*Psst*(1/Ts.t.)	V11:=V11+1	
	(E>1) AND (V1=0) AND (V11=(E-1)) AND (V12=0)	E*Psst*(1/Ts.t.)	V1:=1; V11:=0	
	(E>1) AND (V1=0) AND (V11=0) AND (V12=0)	E*(1-Psst)*(1/Ts.t.)	V12:=1	
	(E>1) AND (V1=0) AND (V11=0) AND ((V12>0) AND (V12<(E-1)))	E*(1-Psst)*(1/Ts.t.)	V12:=V12+1	
	(E>1) AND (V1=0) AND (V11=0) AND (V12=(E-1))	E*(1-Psst)*(1/Ts.t.)	V1:=2; V6:=3; V12:=0	
BE2	(E=1) AND (V1=2) AND (V6=3)	Psst*(1/Ts.t.)	V1:=3; V6:=1	
	(E=1) AND (V1=2) AND (V6=3)	(1-Psst)*(1/Ts.t.)	V1:=4; V6:=2	
	(E>1) AND (V1=2) AND (V6=3) AND (V11=0) AND (V12=0)	E*Psst*(1/Ts.t.)	V11:=1	
	(E>1) AND (V1=2) AND (V6=3) AND ((V11>0) AND (V11<(E-1))) AND (V12=0)	E*Psst*(1/Ts.t.)	V11:=V11+1	
	(E>1) AND (V1=2) AND (V6=3) AND (V11=(E-1)) AND (V12=0)	E*Psst*(1/Ts.t.)	V1:=3; V6:=1; V11:=0	
	(E>1) AND (V1=2) AND (V6=3) AND (V11=0) AND (V12=0)	E*(1-Psst)*(1/Ts.t.)	V12:=1	
	(E>1) AND (V1=2) AND (V6=3) AND (V11=0) AND ((V12>0) AND (V12<(E-1)))	E*(1-Psst)*(1/Ts.t.)	V12:=V12+1	
	(E>1) AND (V1=2) AND (V6=3) AND (V11=0) AND (V12=(E-1))	E*(1-Psst)*(1/Ts.t.)	V1:=4; V6:=2; V12:=0	
BE5	(E=1) AND ((V1=1) OR (V1=3)) AND (V2=0) AND (V3>=1)	Pdt*(1/Td.t.)	V2:=1	
	(E=1) AND ((V1=1) OR (V1=3)) AND (V2=0) AND (V3>=1) AND (V9=0)	(1-Pdt)*(1/Td.t.)	V2:=2; V9:=2	
	(E>1) AND ((V1=1) OR (V1=3)) AND (V2=0) AND (V3>=1) AND (V11=0) AND (V12=0)	E*Pdt*(1/Td.t.)	V11:=1	
	(E>1) AND ((V1=1) OR (V1=3)) AND (V2=0) AND (V3>=1) AND ((V11>0) AND (V11<(E-1))) AND (V12=0)	E*Pdt*(1/Td.t.)	V11:=V11+1	
	(E>1) AND ((V1=1) OR (V1=3)) AND (V2=0) AND (V3>=1) AND (V11=(E-1)) AND (V12=0)	E*Pdt*(1/Td.t.)	V2:=1; V11:=0	
	(E>1) AND ((V1=1) OR (V1=3)) AND (V2=0) AND (V3>=1) AND (V9=0) AND (V11=0) AND (V12=0)	E*(1-Pdt)*(1/Td.t.)	V12:=1	
	(E>1) AND ((V1=1) OR (V1=3)) AND (V2=0) AND (V3>=1) AND (V9=0) AND (V11=0) AND ((V12>0) AND (V12<(E-1)))	E*(1-Pdt)*(1/Td.t.)	V12:=V12+1	
	(E>1) AND ((V1=1) OR (V1=3)) AND (V2=0) AND (V3>=1) AND (V9=0) AND (V11=0) AND (V12=(E-1))	E*(1-Pdt)*(1/Td.t.)	V2:=2; V9:=2; V12:=0	
	.....			

**Table 2.** Dimensions of the model in the form of a state graph and transitions for the different values of the Erlang distribution law.

Order of Erlang distribution law, E	Number of states	Number of transitions
1	466	872
2	498	936
5	562	1064
10	682	1304

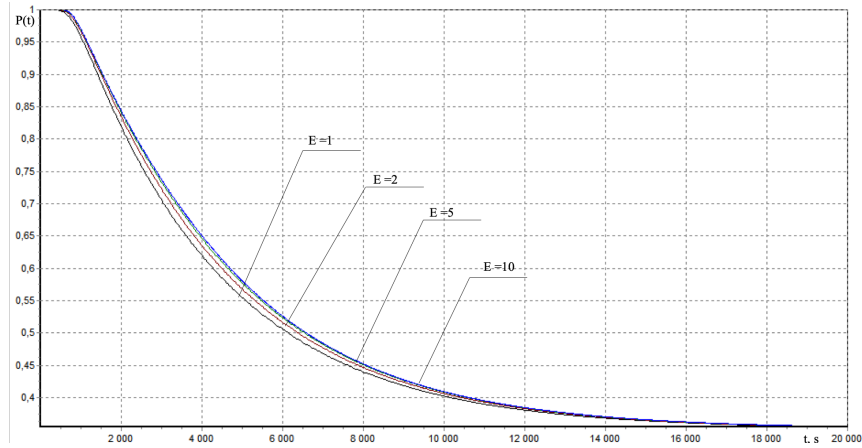


Fig. 6. The obtained results for the research case 2.

**Conclusion on Task 2.** The obtained results under the research case 2 reflect the expected.

**Task 3 for Validation.** It is necessary to check whether the model shows the typical difference between the dependencies of value of the task non-performing probability from the observation interval using the exponential distribution law and the Erlang distribution law of the 2nd, 5th and 10th orders for the duration of the procedures.

**Expected Results.** For the research case 3, the higher the order of the law, the later begins to fall the task non-performing probability.

**Obtained Results.** The obtained results of the research case 3 for the Erlang distribution law of the different orders are presented in Fig. 7.

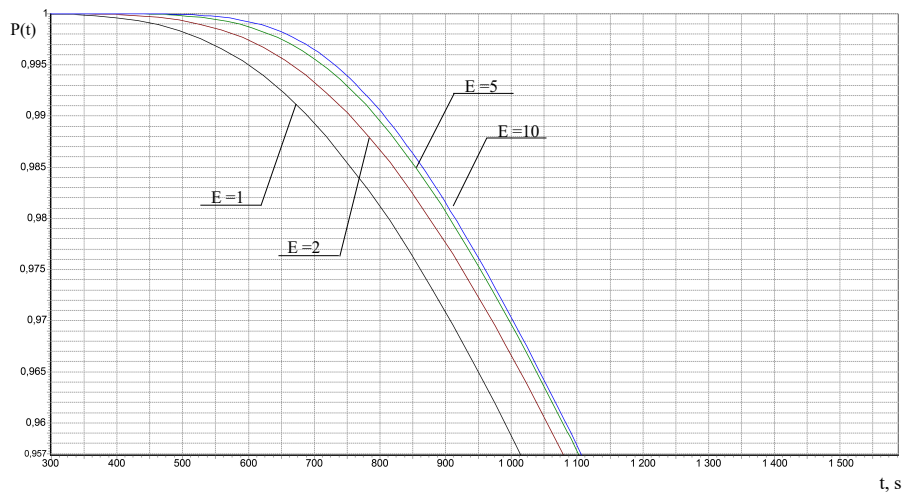


Fig. 7. The obtained results for the research case 3.

**Conclusion on Task 3.** The analysis of the obtained results shows that the difference between the values of the task non-performing probability at a given interval of observation, determined using the Erlang law and the exponential distribution law, increases with the increase of the order of the Erlang's law. In the conducted research cases, the direction of the dependence of the task non-performing probability to the limit value with the increase of the order of the distribution law of Erlang is seen. This is useful for the results accuracy, because in reality the duration of the procedures is fixed.

## 5 Conclusions and Future Work

The discrete-continuous stochastic model of the functional behavior of the insulin pump in a form of the structural automaton model using the Erlang phase method was developed. The development process of the DCSM that includes definition of assumptions to the model, description of basic events and structure of a state vector, development of a SAM are presented. The validation procedure of the developed DCSM model with the exponential distribution law has been conducted. The results of this validation did not meet expectations, so the DCSM was updated using the Erlang phase method. The results show the limit value of the task non-performing probability. The obtained stationary values can be used for further safety modeling.

Next steps of research will be dedicated to refine and decompose some of the procedures occurring in the insulin pump. Besides, it would be interesting and important to research generalized model of system behavior considering different reasons of failures including ones caused by attacks on the device and IoT system as a whole [8,17].

## References

1. Lund, D., MacGillivray, C., Turner, V., Morales, M.: Worldwide and Regional Internet of Things (IoT) 2014–2020 Forecast: A Virtuous Circle of Proven Value and Demand, In: IDC, Framingham, (2014).
2. Understanding the Internet of Things (IoT). London: GSM Association, p. 14 (2014).
3. World Healthcare Organization, Global report on diabetes (2016).
4. Manufacturer and User Facility Device Experience Database - (MAUDE), [www.fda.gov/MedicalDevices/DeviceRegulationandGuidance/PostmarketRequirements/ReportingAdverseEvents/ucm127891.htm](http://www.fda.gov/MedicalDevices/DeviceRegulationandGuidance/PostmarketRequirements/ReportingAdverseEvents/ucm127891.htm), last accessed 2019/03/15.
5. Hei, X., Du, X., Lin, S., Lee, I., Sokolsky, O.: Patient Infusion Pattern based Access Control Schemes for Wireless Insulin Pump System, In: IEEE Transactions on Parallel and Distributed Systems, vol. 26, no. 11, pp. 3108-3121 (2015). DOI: 10.1109/tpds.2014.2370045.
6. Laplante, P., Kassab, M., Laplante, N., Voas, J.: Building Caring Healthcare Systems in the Internet of Things, In: IEEE Systems Journal, vol. 12, no. 3, pp. 3030-3037 (2018). DOI: 10.1109/jsyst.2017.2662602.
7. Strielkina, A., Uzun, D., Kharchenko, V.: Modelling of healthcare IoT using the queueing theory, In: 2017 9th IEEE International Conference on Intelligent Data Acquisition and

- Advanced Computing Systems: Technology and Applications (IDAACS) (2017). DOI: 10.1109/idaacs.2017.8095207.
8. Strielkina, A., Kharchenko, V., Uzun, D.: Availability models for healthcare IoT systems: Classification and research considering attacks on vulnerabilities, In: 2018 IEEE 9th International Conference on Dependable Systems, Services and Technologies (DESSERT), (2018). DOI: 10.1109/dessert.2018.8409099.
  9. Volochiy, B., Zmysnyi, M., Ozirkovskyy, L., Onyschchenko, V., Salnyk, Y.: Improvement of fidelity of moving objects classification in guard signaling complexes with seismic sensors, In: *Informatyka Automatyka Pomiary w Gospodarce i Ochronie Środowiska*, vol. 8, no. 4, pp. 36-39 (2018). DOI: 10.5604/01.3001.0012.8025.
  10. Volochiy, B., Mandziy, B., Ozirkovskiy, M.: Extending the Features of Software for Reliability Analysis of Fault-tolerant Systems, In: *Computational problems of electrical engineering*, vol. 2, no. 2, pp. 113-121 (2012).
  11. State Standard of Ukraine 2862 – 94, Methods for calculating reliability factors, Kyiv, 17 p. (1994) (in Ukrainian).
  12. Koks, D.R., Smit, V.L.: *Queueing Theory*. Moscow, Mir Publ., (1966) (in Russian).
  13. Koks, D.R., Smit, V.L.: *Renewal Theory*, Moscow, Soviet Radio Publ., (1967) (in Russian).
  14. Klejnrok, L.: *Queueing Systems. Vol. I: Theory*, Moscow, Mashinostroenie Publ., (1979). (in Russian).
  15. Y. Zhang, Y., Jones, P., Jetley, R.: A Hazard Analysis for a Generic Insulin Infusion Pump, In: *Journal of Diabetes Science and Technology*, vol. 4, no. 2, pp. 263-283 (2010). DOI: 10.1177/193229681000400207.
  16. Chen, Y., Lawford, M., Wang, H., Wassying, A.: Insulin Pump Software Certification, In: *Foundations of Health Information Engineering and Systems*, pp. 87-106 (2014).
  17. Strielkina, A., Kharchenko, V., Uzun, D.: Availability Models of the Healthcare Internet of Things System Taking into Account Countermeasures Selection", In: *Information and Communication Technologies in Education, Research, and Industrial Applications*, pp. 220-242, (2019). DOI: 10.1007/978-3-030-13929-2\_11.
  18. Fedasyuk, D., Volochiy, S.: Method of developing the structural-automaton models of fault-tolerant systems, In: 2017 14th International Conference The Experience of Designing and Application of CAD Systems in Microelectronics (CADSM) (2017). DOI: 10.1109/cadsm.2017.7916076.
  19. Strielkina, A., Volochiy, B., Kharchenko, V.: Model of Functional Behavior of Healthcare Internet of Things Device, In: 2019 IEEE 10th International Conference on Dependable Systems, Services and Technologies (DESSERT) (2019). (in publish)
  20. Martin, J.: *Systems analysis for data transmission*. Flatiron Pub. (1972).
  21. Volochiy, S., Fedasyuk, D., Chopey, R.: Formalized development of the state transition graphs using the Erlang phase method, In: 2017 9th IEEE International Conference on Intelligent Data Acquisition and Advanced Computing Systems: Technology and Applications (IDAACS) (2017). DOI: 10.1109/IDAACS.2017.8095255.

# High-Speed Privacy Amplification Method for Deterministic Quantum Cryptography Protocols Using Pairs of Entangled Qutrits

Zhengbing Hu<sup>1</sup>, Sergiy Gnatyuk<sup>2,3</sup>, Tetyana Okhrimenko (Zhmurko)<sup>2</sup>,  
Vasyl Kinzeryavyy<sup>2</sup>, Maksim Iavich<sup>4</sup>, Khalicha Yubuzova<sup>5</sup>

<sup>1</sup>Central China Normal University, Wuhan, China

<sup>2</sup>National Aviation University, Kyiv, Ukraine

<sup>3</sup>Yessenov University, Aktau, Kazakhstan

<sup>4</sup>Scientific Cyber Security Association, Tbilisi, Georgia

<sup>5</sup>Satbayev University, Almaty, Kazakhstan

hzb@mail.ccnu.edu.cn s.gnatyuk@nau.edu.ua t.zhmurko@nau.edu.ua  
v.kinzeryavyy@nau.edu.ua m.iavich@scsa.ge hali4a@mail.ru

**Abstract.** With the measureless, huge and rapid data exchange in network environments and increasing the attackers capabilities, quantity and quality of violations in cyberspace, information security has become the most important process for data storage and communication. Reliability of traditional methods for ensuring confidentiality is questionable, taking into account contemporary threats. Thereby, search of alternative methods and means for security is urgent issue. Significant interest causes quantum cryptography, which do not depend on computing or other capabilities of intruder, uses specific unique properties of quantum particles, and based on the inviolability of quantum physics laws. One of the most advanced quantum cryptography technology is quantum secure direct communication, which can transmit information directly by open channel, but it has only asymptotic security to non-coherent attacks and, certainly requires some methods for security amplification. In this regard, high-speed privacy amplification method for quantum cryptography protocols was developed. To evaluate the effectiveness of this method was developed a methodology for experimental research, under which comparing of its performance with known method was made. According to the obtained results, the proposed method has a speed faster against analogs at the same level of security against non-coherent attacks.

**Keywords:** Information and Communication Technologies, Information Security, Quantum Cryptography, Quantum Secure Direct Communication, Qutrit, Deterministic Protocol, Security Amplification.

## 1. Introduction

Today urgency of the cybersecurity problem is beyond any doubt – every day each citizen is faced with necessity to use information and communication technologies

(ICT) – from using social networks and posting information about personal data online to using ATMs, bank accounts etc. In this regard, the issue of ensuring confidentiality in conditions of growing quantity and quality of violations in cyberspace acutely raises. The cyberspace constantly improved and developed along with technologies which in turn, complicates the process of identifying, analyzing and combating them. Reliability of traditional methods to ensure the confidentiality, which is usually provided by means of symmetric (secret key cryptography) [15] and/or asymmetric (public key cryptography) methods, pose a challenge taking into account modern threat. For symmetric methods is typical problem of secret keys distribution and asymmetric methods solve mentioned problem but these methods are slow and need significant computing resources [5, 6, 8, 10, 13]. Moreover, security of traditional cryptosystems depends on the computing capabilities of intruder and based on hypothetical inability to solve a certain class of mathematical problems in polynomial time – factorization and logarithmation in discrete fields of large size etc (excluding post-quantum cryptosystems). However, this hypothesis can be refuted by using, for example, many qubits quantum computers (D-Wave 2X), GRID-technologies, HPC and other modern ICT [6, 8, 9, 13].

Considering all of the aforesaid, quantum cryptography (QC) causes great interest, it is independent from computing power of intruder, uses specific unique properties of quantum particles, and based on the inviolability of the quantum physics laws. Main advantages of QC methods are possibility of the accurate intruder detection and providing, in some cases, theoretical-information security. At present these methods and systems have passed a difficult way from theoretical assumptions and laboratory experiments to full commercial decisions [5, 6, 8, 13].

The most highly developed QC technology is quantum key distribution [5, 7] and other important direction is quantum secure direct communication (QSDC), which can transmit information directly by open channel (without its encryption – the problem of key distribution is neutralized). Today exists large number of QSDC methods [1, 5, 6, 13, 14], which are based on different quantum technologies and can be used for secure information transferring (using qubits or qudits), and also for cryptographic keys distribution.

Requirements for QSDC protocols security is considerably higher than for quantum key distribution protocols, because in QSDC protocols every bit of information is confidential and shouldn't be intercepted by eavesdropper. Thus, although QSDC protocols completely eliminates the problem of secret cryptographic keys distribution, these have only asymptotic security from non-coherent attacks [12] and certainly require security amplification methods [13, 14]. Since the probability to detect this attack after a single eavesdropping control is less than “1” for all known QSDC protocols, and errors in eavesdropping control mode will be created not only by attack, but also by natural noise in quantum communication channel, it follows that it is necessary to perform a certain amount of rounds of eavesdropping control before it can confidently detect an attack. As far as both modes (eavesdropping control and message sending) should necessarily be alternated randomly, a certain amount of information can be intercepted by eavesdropper [6, 13]. Obviously that its necessary to apply additional procedures and methods to enhance security. In [13, 14] known privacy amplification methods (PAM) for QSDC protocols is described, but this method uses procedures that significantly slow down protocol work, as far as it is necessary to apply reverse hashing using reversible ternary matrices. Generating of



such matrices requires more time and resource costs (significant number of mathematical transformations over the Galois field).

From the perspective of information capacity the most effective methods are those that use trit quantum systems. Due to relative natural-logarithmic information density (Fig. 1), which is described by function

$$Y(a) = \frac{\ln y(a)}{a} = \frac{\ln a}{a},$$

where  $a$  is radix, it follows that system with base equal to the base of natural logarithms (i.e. is equal to  $e$ ) has the highest information density. For fixed-point representation system it's ternary system [2], in the case of quantum systems it's three-level quantum system named *qutrits*.

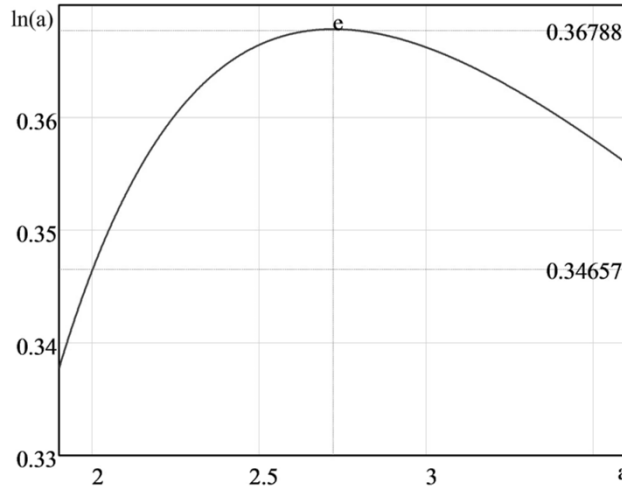


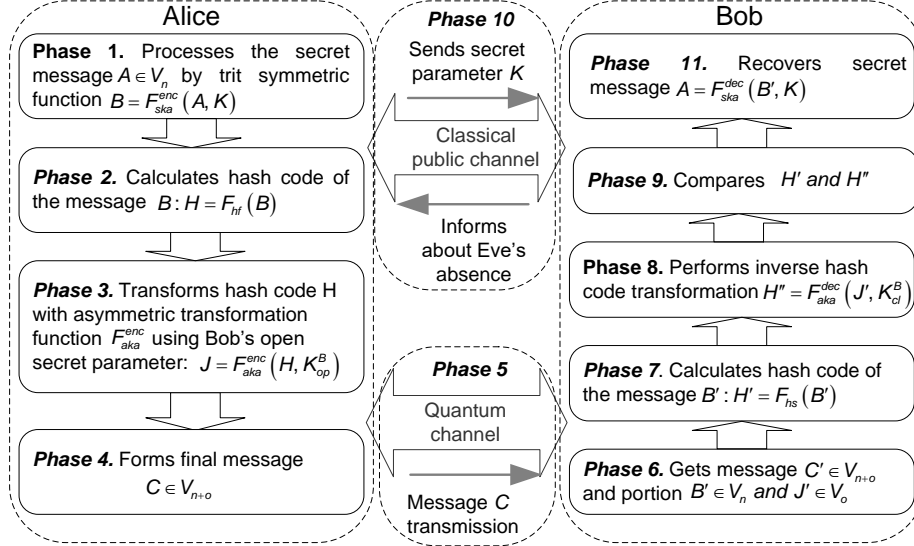
Fig. 1. Relative natural-logarithmic information density

The purpose of this paper is developing a high-speed PAM for QC protocols using pairs of entangled qutrits and conducting experimental research to evaluate its effectiveness.

## 2. New Privacy Amplification Method Development

Assume it's necessary to send message  $A \in V_n$  by QSDC protocol (using both PAM), where  $V_n = \{0,1,2\}^n$ ,  $n = r \cdot l$ ,  $r \in N$  is data block size, and  $l \in N$  is amount of data blocks. To compare the speed of messages  $A$  transmission by QSDC protocol (with switching frequency  $q$ ) were evaluated runtime of each specific stage. To evaluate the runtime of each phase following designations was used:  $V_{gen}$  are trit sequences generating speed;  $V_{kv}$  and  $V_{kl}$  are trit sequences transfer speed by quantum and classical channels respectively;  $V_x$  is execution speed for arithmetic operations in the  $GF(3)$  field.

Consider proposed high-speed PAM for QC protocols (Fig. 2) [5, 12, 14], will assume that Alice and Bob are legitimate users, Eve is eavesdropper.



**Fig. 2.** Scheme of PAM for QSDC protocol realization

In accordance to scheme described on Fig. 2, Alice sends message  $A$  to Bob using following Phases:

**Phase 1.** Alice processes secret message  $A \in V_n$  ( $V_n = \{0,1,2\}^n$ ,  $n \in N$ ) with trit symmetric transformation function  $F_{ska}^{enc}: B = F_{ska}^{enc}(A, K)$ , where  $K$  is secret parameter,  $K \in V_k$ ,  $k \in N$ ,  $k < n$ ,  $F_{ska}^{enc}$  is symmetric transformation function,  $F_{ska}^{enc}: V_n \rightarrow V_n$ ,  $B$  is transformed secret message  $B \in V_n$ .

**Phase 2.** Alice calculates hash code of the message  $B: H = F_{hf}(B)$ , where  $F_{hf}$  is trit hash function,  $F_{hf}: V_n \rightarrow V_h$ ,  $h \in N$ ,  $h < n$ ,  $H$  is hash code of the message  $B$ ,  $H \in V_h$ .

**Phase 3.** Alice transforms hash code  $H$  with asymmetric transformation function  $F_{aka}^{enc}$  using Bob's open secret parameter:  $J = F_{aka}^{enc}(H, K_{op}^B)$ , where  $K_{op}^B$  is Bob's open secret parameter,  $K_{op}^B \in V_p$ ,  $p \in N$ ,  $F_{aka}^{enc}$  is asymmetric transformation function,  $F_{aka}^{enc}: V_h \rightarrow V_o$ ,  $o \in N$ ,  $J$  is transformed hash code  $H$ ,  $J \in V_o$ .

**Phase 4.** Alice forms final message  $C \in V_{n+o}$  for transmitting it to Bob:  $C = (B, J)$ , where  $B \in V_n$ ,  $J \in V_o$ .

**Phase 5.** Occurs message  $C$  transmission by quantum channel using QSDC protocols from Alice to Bob. Even if Eve intercept part of the message  $C$  and still be not detected, then, not knowing the secret parameter  $K$ , she can not restore the original message  $A$ . It should be noted, that Alice and Bob can previously choose

such a value of switching frequency  $q$  between modes of QSDC protocols (from message transmission mode to eavesdropping control mode), with which the probability of Eve's successful attack would be insignificant.

*Phase 6.* Bob gets message  $C' \in V_{n+o}$  and portion  $B' \in V_n$ ,  $J' \in V_o$  and  $J' \in V_o$ .

*Phase 7.* Bob calculates hash code of the message  $B' : H' = F_{hs}(B') : H' = F_{hs}(B')$ , where  $F_{hf}$  is trit hash function,  $F_{hf} : V_n \rightarrow V_h$ ,  $H'$  is hash code of the message  $B'$ ,  $H' \in V_h$ .

*Phase 8.* Bob performs inverse hash code transformation  $H''$  by asymmetric transformation function  $F_{aka}^{dec}$  using his private secret parameter:  $H'' = F_{aka}^{dec}(J', K_{cl}^B)$ , where  $K_{cl}^B$  is Bob's private parameter,  $K_{cl}^B \in V_p$ ,  $F_{aka}^{dec}$  is asymmetric function of inverse transformation,  $F_{aka}^{dec} : V_o \rightarrow V_h$ .

*Phase 9.* Bob compares  $H'$  and  $H''$  and  $H''$ . If  $H' \neq H''$  it means that message was modified during transmission. Immediately assumed that Eve interfered in communication session. So Bob and Alice interrupted session. According to non-cloning theorem, eavesdropper can not make an exact copy of quantum systems, which are transmitted by communication channel, to conduct measurements over a copy and send the original to legitimate user, without making measurements of it. This forces intruder to measure state of the quantum systems, which are transmitted (or entangle them with their quantum samples) that, according to postulate of measurement, causes change of their conditions (in such case  $B' \neq B$  and  $H' \neq H''$ ). If  $H' = H''$  it means that there was no Eve interference and  $B' = B$ .

*Phase 10.* Bob informs Alice that during message transmission was no unauthorized access. Alice in turn by open communication channel sends to Bob secret parameter  $K$ .

*Phase 11.* Bob recovers secret message  $A$  processes trit symmetrical reverse transformation function  $F_{ska}^{dec} : A = F_{ska}^{dec}(B', K)$ ,  $F_{ska}^{dec}$  is symmetrical reverse transformation function,  $F_{ska}^{dec} : V_n \rightarrow V_n$ .

As symmetric functions of transformation and reverse transformation can be used or trit block or stream transformation (however, these procedures are not encryption, as far as  $K$  transmitted by open channel to establish the legitimacy of the user, which is not conform to the principles of cryptography where key is secret parameter and it doesn't transmit using open channel). Note that in such construction of QSDC protocols, switching frequency  $q$  between modes of their work can be reduced to a minimum (from recommended value 0.5 to 0.05, based on the assumption that additional security procedures and functions were implemented), at the same time will increase speed of protocols and and Eve still be detected (on phases 5 and 9).

To study the proposed PAM for QSDC protocols [4] was developed experimental methodology, according to which were made performances comparison with existing PAM [13, 14]. Both methods are using for deterministic protocols with pairs of entangled qutrits.

In Table 1 presented basic stages of QSDC protocols with application of different PAMs (known [13, 14] and proposed, concept and short review of the method developed by the authors in [4]) and the time of their performance.

**Table 1.** Evaluation of QSDC protocol stages runtime (comparative analysis)

№	Known method		Proposed method	
	Operation	Runtime	Operation	Runtime
1.	$M_i = F_{gen}(K, i, r^2)$	$\frac{l \cdot r^2}{V_{gen}}$	$k_i = F_{gen}(K, i, r)$	$\frac{l \cdot r}{V_{gen}}$
2.	$B_i = A_i \cdot M_i$	$\frac{l \cdot (2r^2 - r)}{V_x}$	$B_i = A_i + k_i$	$\frac{l \cdot r}{V_x}$
3.	$B'_i = F_{kv}(B_i, q)$	$\left(\frac{l \cdot r}{V_{kv}}\right) \cdot (1+q)$	$H = F_{hf}(B)$ $J = F_{aka}^{enc}(H, K_{op}^B)$	$\frac{4 \cdot l \cdot r}{V_x}$
4.	$M'_i = F_{kl}(M_i)$	$\frac{l \cdot r^2}{V_{kl}}$	$B'_i = F_{kv}(B_i, q)$ $J' = F_{kv}(J, q)$	$\left(\frac{l \cdot r + 96}{V_{kv}}\right) \cdot (1+q)$
5.	$(M'_i)^{-1} = F_{obr}(M'_i)$	$\frac{l \cdot (4r^3 - 4r^2)}{V_x}$	$H' = F_{hf}(B')$ $H'' = F_{aka}^{dec}(J', K_{cl}^B)$	$\frac{4 \cdot l \cdot r}{V_x}$
6.	$A'_i = B'_i \cdot (M'_i)^{-1}$	$\frac{l \cdot (2r^2 - r)}{V_x}$	$K' = F_{kl}(K)$	$\frac{96}{V_{kl}}$
7.	-	0	$k'_i = F_{gen}(K', i, r)$	$\frac{l \cdot r}{V_{gen}}$
8.	-	0	$A'_i = B'_i - k'_i$	$\frac{l \cdot r}{V_x}$

Presented in Table 2 formalized operations will be used for experimental study to estimate the speed of known and proposed PAMs.

### 3. Experimental Study of Proposed Method and Discussion

#### *Proposed technique for experiments*

To study the performance of mentioned methods seven experiments with different parameters  $r, l, q, V_{gen}, V_{kv}, V_{kl}$  and  $V_x$  were conducted.

*Experiments purpose* is investigate the efficiency of the developed method in comparison with known and verify its adequacy.

*Input parameters:* trit sequences generating speed ( $V_{gen}$ ), speed of trit sequences transfer by quantum channel ( $V_{kv}$ ), speed of trit sequences transfer by classic channel ( $V_{kl}$ ), execution speed for arithmetic operations in the field  $GF(3)$  ( $V_x$ ), data block size ( $r$ ), amount of data blocks ( $l$ ), switching frequency to listening mode ( $q$ ), known and proposed PAM for QC protocols, step size of changing for each parameter.

*Output parameters:* gathered speed statistics for both methods depending on input parameters.

*Steps of experiments:*

- 1) Fixed basic system settings: trit sequences generating speed ( $V_{gen}$ ), speed of trit sequences transfer by quantum channel ( $V_{kv}$ ), speed of trit sequences transfer by classic channel ( $V_{kl}$ ), execution speed for arithmetic operations in the field  $GF(3)$  ( $V_x$ ), data block size ( $r$ ), amount of data blocks ( $l$ ), switching frequency ( $q$ );
- 2) Next step is simulated performance of all phases of QSDC protocol by using developed software;
- 3) Collected statistics is used to analyze effectiveness of the proposed method for ensuring the security of QC protocols.

*Selecting a step of changing:* changing  $r$  from 4 to 100 (in increments 4). Changing protocols speed ( $V_{gen}$ ,  $V_{kv}$ ,  $V_{kl}$  and  $V_x$ ) from  $10^3$  to  $10^5$ .

### Study and discussion

Experiment 1. Let  $V_x = V_{kl} = 10^6$ ,  $V_{gen} = 10^4$ ,  $V_{kv} = 10^3$ ,  $l = 1000$ ,  $q = 0.5$  for known method of ensuring security of QSDC protocols and  $q = 0.05$  for proposed method. Probability of switching into eavesdropping control mode for proposed method can be reduced to a minimum – from recommended value 0.5 to 0.05.

Fig. 3 shows the results of *experiment 1* to compare QSDC protocol performance for different PAM.

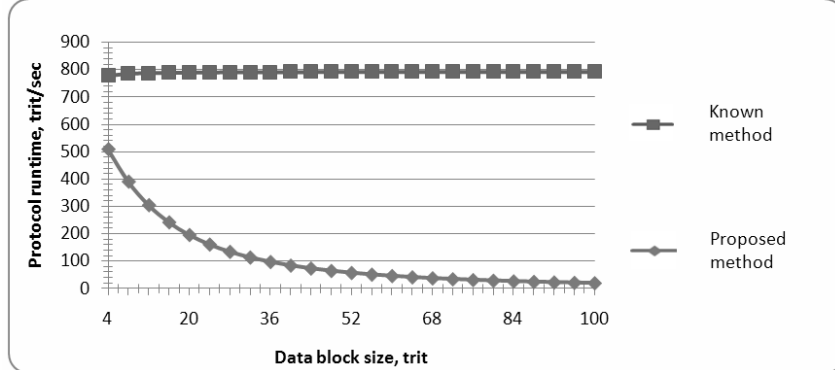


Fig. 3. QSDC protocol speed characteristics comparison (results of experiment 1)

According to experimental results, speed of QSDC protocol with the proposed PAM at least in 1.52 time is higher than speed of the known method (for  $r = 4$ ). Moreover, with increasing  $r$  performance improvements would be even more significant. For example, when  $r = 20$  performance of the proposed method is higher in 4.4 times.

Experiment 2. Let  $V_x = V_{kl} = 10^5$ ,  $V_{gen} = 10^4$ ,  $V_{kv} = 10^3$ ,  $l = 1000$ ,  $q = 0.5$  for known privacy amplification method of QSDC protocols,  $q = 0.05$  for proposed method.

Fig. 4 shows the results of *experiment 2* to compare QSDC protocol performance for different methods of ensuring its security.

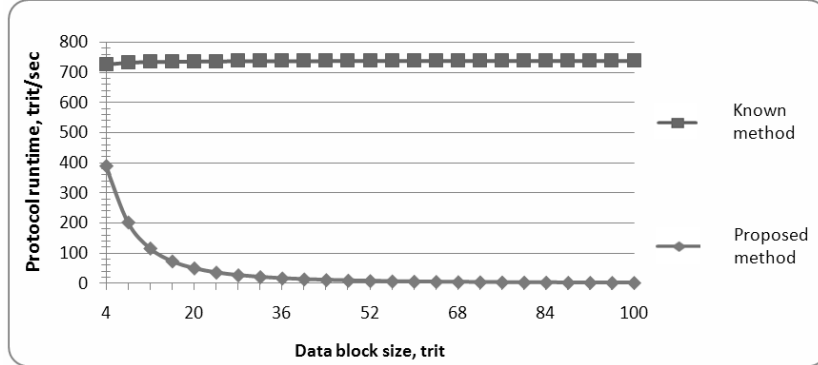


Fig. 4. QSDC protocol speed characteristics comparison (results of experiment 2)

According to experimental results, speed of QSDC protocol with the proposed PAM at least in 1.86 time is higher than speed of the known method (for  $r = 4$ ). Moreover, with increasing  $r$  performance improvements would be even more significant. For example, when  $r = 20$  performance of the proposed method is higher in 14.5 times.

Experiment 3. Let  $V_x = V_{kl} = V_{gen} = 10^5$ ,  $V_{kv} = 10^3$ ,  $l = 1000$ ,  $q = 0.5$  for known privacy amplification method of QSDC protocols,  $q = 0.05$  for proposed method.

Fig. 5 shows the results of *experiment 3* to compare QSDC protocol performance for different methods of ensuring its security.

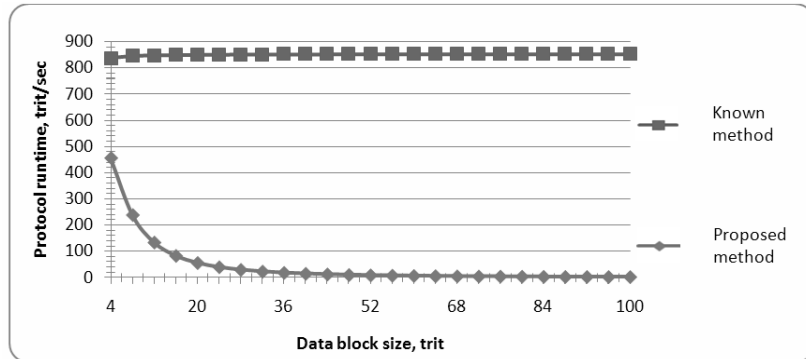


Fig. 5. QSDC protocol speed characteristics comparison (results of experiment 3)

According to experimental results, speed of QSDC protocol with the proposed PAM at least in 1.84 time is higher than speed of the known method (for  $r = 4$ ). Moreover, with increasing  $r$  performance improvements would be even more significant. For example, when  $r = 20$  performance of the proposed method is higher in 15.21 times.

Experiment 4. Let  $V_x = V_{kl} = V_{gen} = 10^5$ ,  $V_{kv} = 10^4$ ,  $l = 1000$ ,  $q = 0.5$  for known privacy amplification method of QSDC protocols,  $q = 0.05$  for proposed method.

Fig. 6 shows the results of *experiment 4* to compare QSDC protocol performance for different methods of ensuring its security.

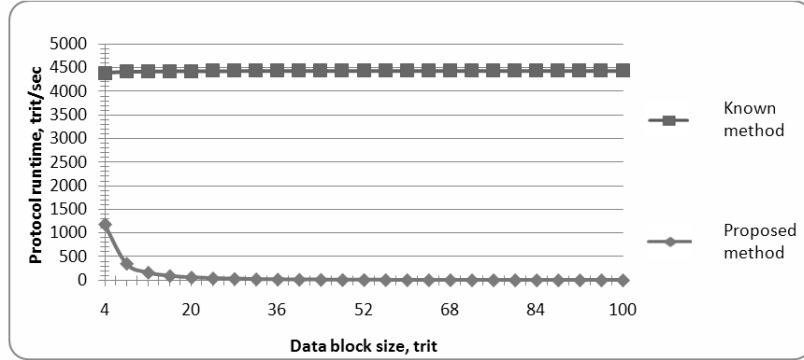


Fig. 6. QSDC protocol speed characteristics comparison (results of experiment 4)

According to experimental results, speed of QSDC protocol with the proposed PAM at least in 3.73 time is higher than speed of the known method (for  $r = 4$ ). Moreover, with increasing  $r$  performance improvements would be even more significant. For example, when  $r = 20$  performance of the proposed method is higher in 73.29 times.

Experiment 5. Let  $V_x = V_{kl} = V_{gen} = V_{kv} = 10^5$ ,  $l = 1000$ ,  $q = 0.5$  for known privacy amplification method of QSDC protocols,  $q = 0.05$  for proposed method.

Fig. 7 shows the results of *experiment 5* to compare QSDC protocol performance for different methods of ensuring its security.

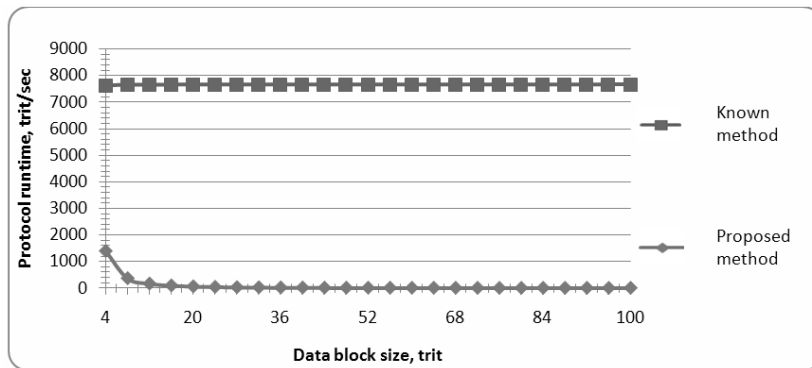


Fig. 7. QSDC protocol speed characteristics comparison (results of experiment 5)

According to experimental results, speed of QSDC protocol with the proposed PAM at least in 5.45 time is higher than speed of the known method (for  $r = 4$ ). Moreover, with increasing  $r$  performance improvements would be even more significant. For example, when  $r = 20$  performance of the proposed method is higher in 125.53 times.

Experiment 6. Let  $V_x = 10^6$ ,  $V_{kl} = 10^5$ ,  $V_{gen} = 10^4$ ,  $V_{kv} = 10^3$ ,  $l = 1000$ ,  $q = 0.5$  for known privacy amplification method of QSDC protocols,  $q = 0.05$  for proposed method.

Fig. 8 shows the results of *experiment 6* to compare QSDC protocol performance for different methods of ensuring its security.

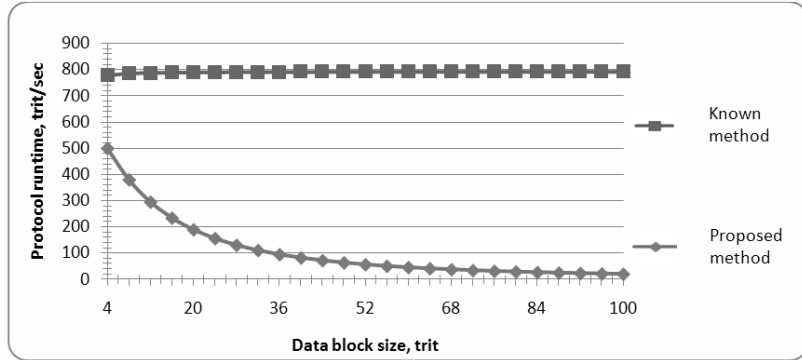


Fig. 8. QSDC protocol speed characteristics comparison (results of experiment 6)

According to experimental results, speed of QSDC protocol with the proposed PAM at least in 1.55 time is higher than speed of the known method (for  $r=4$ ). Moreover, with increasing  $r$  performance improvements would be even more significant. For example, when  $r=20$  performance of the proposed method is higher in 4.18 times.

*Experiment 7.* Let  $V_x = 10^5$ ,  $V_{kl} = 10^6$ ,  $V_{gen} = 10^4$ ,  $V_{kv} = 10^3$ ,  $l = 1000$ ,  $q = 0.5$  for known privacy amplification method of QSDC protocols,  $q = 0.05$  for proposed method.

Fig. 9 shows the results of *experiment 7* to compare QSDC protocol performance for different methods of ensuring its security.

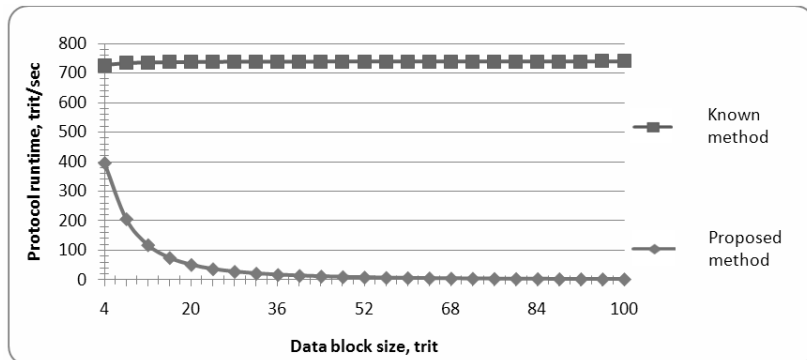
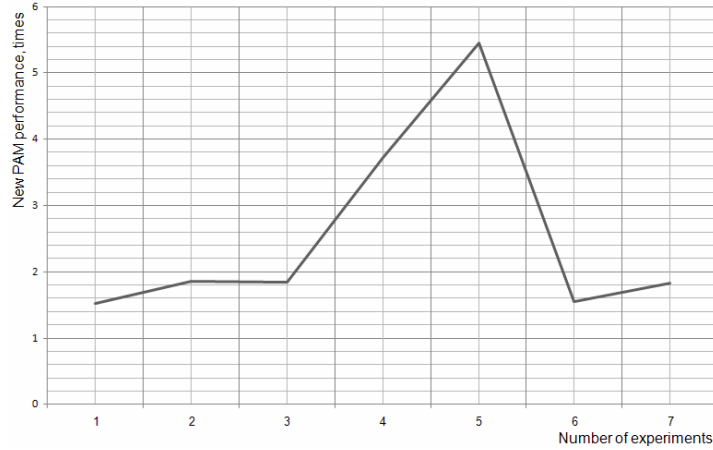


Fig. 9. QSDC protocol speed characteristics comparison (results of experiment 7)

According to experimental results, speed of QSDC protocol with the proposed PAM at least in 1.83 time is higher than speed of the known method (for  $r=4$ ). Moreover, with increasing  $r$  performance improvements would be even more significant. For example, when  $r=20$  performance of the proposed method is higher in 14.39 times.

As can be seen from the above, according to experimental results, speed of QSDC protocol with the proposed PAM at least in 1.52 time is higher than the speed of the known method (Fig. 10).





**Fig. 10.** Comparative analysis of efficiency for QSCD protocols with different PAMs for  $r = 4$

However, it should be noted that these results were obtained for  $r = 4$ . In the paper [4] mentioned, that legitimate users can choose the protocol parameters (block size  $r$ , switching probability to control listening mode  $q$  and other parameters) in a way that probability of Eve's successful non-coherent attack after transmission one block size  $r$  was negligibly small value. Can be concluded, that for effective use of known and proposed PAM for QC protocols recommended size is  $r \geq 20$ , in that case the speed of the proposed method at least higher in 4.4 times.

#### 4. Conclusions

Advanced many qubits quantum computers are threats for traditional cryptosystems (excluding post-quantum systems) and using of QC is alternative for some security tasks solving (intruder detection, theoretical-information security providing in some cases etc). But through it all QC has some actual problems devoted to high speed and security providing. In this study high-speed PAM for deterministic QC protocols was developed. It allows to minimize the amount of switching between protocol modes (message transmission and eavesdropping control), and increase protocol speed at least in 1.52 time, while maintaining the security against non-coherent attacks. It is achieved by use of quantum integrity checking function and trit symmetric function, that are developed in this method. Also in the study simulation of QSDC protocol work with proposed and known PAMs for QC protocols to non-coherent attacks was conducted, which confirmed the adequacy of the proposed method and its ability to use for privacy amplification of deterministic QC protocols using pairs of entangled qutrits. According to given results, speed of QSDC protocol with the proposed PAM is higher (when  $r = 4$ ) than the speed of the known method, but as far as in QC recommended size is  $r \geq 20$ , in that case the speed of the proposed method is higher at least in 4.4 times. From viewpoint of limitations, for effective practical application of the developed method is necessary to use existing (for example [3, 11]) cryptographically secure generators of pseudorandom sequence or develop new, which would satisfy the relevant requirements including the generation of ternary sequences.

## Acknowledgments

This scientific work was financially supported by self-determined research funds of CCNU from the colleges' basic research and operation of MOE (CCNU16A02015), Joint Project of Shota Rustaveli National Science Foundation and Science & Technology Center in Ukraine [№ STCU-2016-08] as well as Ukrainian Young Scientists Project № 0117U006770.

## References

1. Bostrom K., Felbinger T. (2002) Deterministic secure direct communication using entanglement, *Physical Review Letters*, vol. 89, issue 18, p. 187902.
2. Deibuk V.G., Biloshytskyi A.V. (2015) Design of a Ternary Reversible / Quantum Adder using Genetic Algorithm, *International Journal of Information Technology and Computer Science*, issue 09, p. 38-45.
3. Gaeini A., Mirghadri A., Jandaghi G., Keshavarzi B. (2016) Comparing Some Pseudo-Random Number Generators and Cryptography Algorithms Using a General Evaluation Pattern, *International Journal of Information Technology and Computer Science*, issue 9, p. 25-31.
4. Gnatyuk S., Zhmurko T., Falat P. (2015) Efficiency Increasing Method for Quantum Secure Direct Communication Protocols, Proceedings of the 2015 IEEE 8th International Conference on «Intelligent Data Acquisition and Advanced Computing Systems: Technology and Applications» (IDAACS'2015), Warsaw, Poland, September 24-26, 2015: vol. 1, p. 468-472.
5. Korchenko O., Vasiliu Ye., Gnatyuk S. (2010) Modern Quantum Technologies of Information Security Against Cyberterrorist Attacks, *Aviation*, vol. 14, issue 2, p. 58-69.
6. Advanced Technologies of Quantum Key Distribution, Monograph [edited by Sergiy Gnatyuk], London, Great Britain : InTech, 227 p. (2018).
7. Mohammad Omer K. Jasim, Abbas Safia, El-Horbaty El-Sayed M., Salem Abdel-Badeeh M. (2015) Innovative Method for Enhancing Key Generation and Management in the AES-Algorithm, *International Journal of Computer Network and Information Security*, issue 4, p. 14-20.
8. Nielsen M.A., Chuang I.L. (2010) *Quantum computation an quantum information*, Cambridge, Cambridge University Press, 708 p.
9. Rahamana Mijanur, Islamb Md. Masudul An Overview on Quantum Computing as a Service (QCaaS): Probability or Possibility (2016) *International Journal of Mathematical Sciences and Computing*, 2016, Issue 1, P. 16-22. DOI: 10.5815/ijmsc.2016.01.02
10. Reddy P. Lokesh Kumar, Reddy B. Rama Bhupal, Krishna S. Rama (2012) Multi-User Quantum Key Distribution Using Wavelength Division Multiplexing, *International Journal of Computer Network and Information Security*, issue 6, p. 43-48.
11. Aleksander M., Dubchak L., Chyzh V., Naglik A. et al (2015) Implementation technology software-defined networking in Wireless Sensor Networks, *Proceedings of 2015 IEEE 8th International Conference on Intelligent Data Acquisition and Advanced Computing Systems: Technology and Applications (IDAACS)*, Warsaw, Poland, September 24-26, 2015.
12. Vasiliu Ye. (2011) Non-coherent attack on the ping-pong protocol with completely entangled pairs of qutrits, *Quantum Information Processing*, April 2011, vol. 10, issue 2, p. 189-202.
13. Vasiliu Ye., Milchevich V., Nikolayenko S., Milchevich A. (2013) Secured systems for transmission of confidential information on the basis of the quantum cryptography protocols: monograph, Kharkiv: Digital Typography № 1, 168 p. (in Russian).
14. Vasiliu Ye., Nikolayenko S. (2014) Modified Method of Security Amplification for Quantum Direct Communication Protocols, *1<sup>st</sup> IEEE International Scientific-Practical Conference Problems of Infocommunications Science and Technology*, (PIC S&T '2014), p. 190-191.
15. Gnatyuk S., Kinzeryavyy V., Iavich M., Prysiazhnyi D., Yubuzova Kh. (2018) High-Performance Reliable Block Encryption Algorithms Secured against Linear and Differential Cryptanalytic Attacks, *CEUR Workshop Proceedings (Proceedings of the 14<sup>th</sup> International Conference on ICT in Education, Research and Industrial Applications. Integration, Harmonization and Knowledge Transfer*, Kyiv, Ukraine, May 14-17, 2018), vol. 2104, p. 657-668.

# Quality Assessment of Unmanned Aerial Systems Using Bayesian Trust Networks Processing of Testing Data

Ol'ha Bashyns'ka<sup>1</sup>, Volodymyr Kazymyr<sup>2</sup>, Sergii Nesterenko<sup>3</sup>

<sup>1</sup>Chernihiv National University of Technology, 95 Shevchenka Str., 14035 Chernihiv, Ukraine,  
bashinskaolga@gmail.com

<sup>2</sup>Chernihiv National University of Technology, 95 Shevchenka Str., 14035 Chernihiv, Ukraine,  
vvkazymyr@gmail.com

<sup>3</sup>State Scientific and Research Institute of Arms Testing and Certification of the Ukraine Armed Forces, 1 Strilets'ka Str., 14033 Chernihiv, Ukraine,  
cranoxy@gmail.com

**Abstract.** Unmanned aerial systems (UAS) recently have been rapidly developing both conceptually and technically. The reason for this is that they have become an effective alternative to traditional means and technical systems in a number of applications. The tasks, which are solved with the help of UAS, traditionally include air surveillance, intelligence and communication support both at daytime or at night and in different meteorological conditions. At the same time, the suitability of the UAS for the performance of certain tasks is determined by their qualitative metrics, which must first be evaluated during the tests. As a rule, this is done according to the technical diagnostics because its results are reflected in the quality metrics. But in this case there is a problem of the determination the required duration and content of testing to ensure the economy of resources and time. With proper planning and execution of expertise, it is possible to avoid situations where further testing becomes ineffective. The article describes an express method for assessing the qualitative metrics of UAS by data of technical diagnostics based on use of Bayesian trust networks (BNT). The proposed method allows not only quickly determine the duration of test program, but also a list of the most important characteristics that affect the quality of UAS. In addition, the use of BNT allows to evaluate these characteristics and to correct test plan in real time that increasing the reliability and efficiency of the conformity assessment.

**Keywords:** Unmanned Aerial Systems, Testing, Quality Metrics, Technical Diagnosis, Bayesian Networks of Trust.

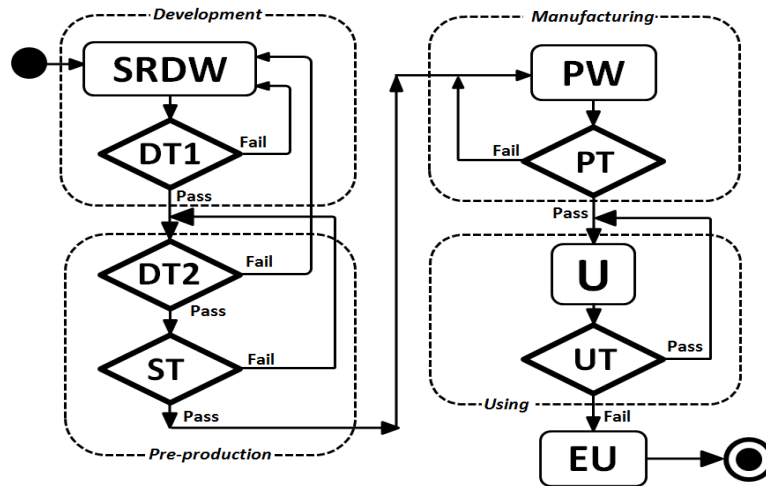
## 1 Introduction

Unmanned aerial systems recently have been rapidly developing [1] both conceptually and technically. The reason for this is they quite unexpectedly found as effective alternative to traditional means and technical systems in a number of areas of use. The tasks that are solved with the help of UAS traditionally include air surveillance, reconnaissance and communication support both in daytime and at night, and under

different meteorological conditions. Recently, the task of using UAS for delivery to the required place cargo, both civil and military, is becoming more and more important. For these reasons becomes understandable constant attention of scientists and industry to the issues of further improvement of UAS, increasing their quality and efficiency.

As in most modern technical systems, energy, material and information flows interact in the UAS by complicated way, which greatly complicates the realization the tasks of all phases of the life cycle (Fig. 1).

The examinations perform a special role in the lifecycle of the UAS. Their purpose is to determine experimentally the actual (achieved) properties' characteristics of the sample tested and determine the degree of its compliance with the technical task or technical specifications received from the developer. Thus the task of rational organization of examinations is relevant.



**Fig. 1.** The place of tests (examinations) in the UAS lifecycle. SRDW – scientific researches and design works; DT1 – developer’s testing; DT2 – defining departmental tests; ST – state tests; PW – UAS production; PT – test by the manufacturer; U – use (exploitation); UT – periodical tests during exploitation; EU – end utilization.

The testing of the UAS is a complex operation. For their implementation the considerable material, time and organizational resources are spent, so the practice put forward the following objectives in relation to the examinations:

- to reduce the examination duration and cost, if possible to eliminate non-rational time expenditures;
- to increase the conclusions validity of the examinations, reduce the influence of subjectivity.

In the process of examination, the decision making person (DMP) constantly receives technical diagnostic data. These data affect qualitative metrics (QM) assess-

ment of which is the purpose of the expertise. The use of BNT allows DMP to assess which test factors affect quality metrics most strongly. By proper planning and performing the test program it allows to avoiding situations where further testing becomes inefficient.

The purpose of the article is to describe the method of assessing the UAS quality of by the technical diagnostics data and BNT to increase the validity of decisions on their compliance with the system requirements.

## 2 Actual Scientific Researches and Issues Analysis

In accordance with [2], under the test of industrial products (engineering samples), one understood an experimental determination of the quantitative or qualitative characteristics of the test object that arises from:

- result of the impact on it;
- it's functioning;
- process of modeling an object or affecting it.

In [3] the traditional method of UAS examination is described. Here it is offered to design the systems and technologies to UAS self-control for predict them technical condition. The proposed self-diagnostic approach is capable to facilitate and speed up the testing process. But it not decides the problem of express analysis of quality metrics and correction the test plan in real time.

The article formulates the proposals, how it is possible on the basis of modeling:

- to automate the process of identifying complex failures;
- to analyze impacts and generate recommendations;
- to use this information to assist in assessing the diagnostic capabilities and to make the right choice of sensor types and models.

At the same time, more and more researchers' attention is attracted [4] to the methodology of using BNT to solve a variety of technical problems, especially those related to uncertainty and the need to combine expert estimates with numerical data accumulated in various databases.

BNT now deservedly occupies [5] the place of one of the most productive mathematical approaches that allows flexible and adequate description of decision making by qualified experts in the diagnosis of complex systems under uncertainty. Models built on these principles show themselves well in the tasks associated with incomplete and inaccurate information. With the help of BNT significant advances have been made in such areas as medicine (diagnosis of lymph nodes, refinement of diagnoses), automatic speech recognition systems, image processing, classification of data of various natures, and others.

The author rightly points out that the probabilistic approach to the solution of complex technical problems based on the mathematical apparatus of BNT has the following main advantages:

- the simulation results obtained by experts' knowledge and presented as the structure of the trust graph and as the form of probabilistic tables in nodes of the trust network are more reliable;
- here is the ability to save time and resources;
- there is more possibility of a quick understanding of situations and visual representation of the elements (variables) interactions when technical system is modeled in the form of BNT;
- there is the possibility to adjust the models used and their parameters, taking into account the receipt of new information about the behavior of the object being studied.

Despite the fact that Bayesian networks are given a lot of attention in the world scientific literature, the principles of their construction and use are not yet sufficiently covered in domestic publications, which greatly impedes their understanding and application.

### 3 Definition Methodology for UAS Quality Indicators with Use the Data of Technical Diagnosis

UAS QM is semantically defined as a tuple

$$QM = \langle Y, M \rangle, \quad (1)$$

where  $Y = \{Y_i\}$  is a set of functions (properties) of a technical sample that are relevant to  $Q$  and which are tested during its examination;

$M$  – the numerical representation of the  $QM$  which serves to quantify it. In most cases, according to [6, 7],  $M_Q$  are calculated as relative values:

$$M_Q = \frac{|X|}{|Y|} \text{ or } M_Q = \frac{|Z|}{|Y|}, \quad (2)$$

where  $|A|$  means the power (number of elements) of the set  $A$ .

In the formula (2):

$X = \{X_j\}$ ,  $X \subseteq Y$  is the set of functions (properties) of the technical sample that are performed according to the  $Q$  during the examination;

$Z = Y \setminus X$  is the set of functions (properties) of the technical sample that are not performed according to the  $Q$  during the examination.

Properties  $Y$  get defined during the technical samples testing through the implementation of diagnostic procedures which are components of technical diagnostics (TD).

The semantics of technical diagnostics is determined on the logical model, which, in turn, corresponds to the system of sets

$$TD = \langle T, M \rangle \quad (3)$$

where  $T = \{T_i \mid i \in (1 \dots m), X_i \leftrightarrow T_i\}$  is a set of tests that are performed (or symptoms observed) when technical sample is examining;

$M = \{M_j \mid j \in (1 \dots k)\}$  – is the set of QM, which are calculated from the results of tests  $T$  by the formulas (2).

The logical connection between  $T$  and  $M$  can be illustrated by the incidence matrix  $TM$ :

$$TM = \begin{array}{ccccc|c} & T_1 & T_2 & T_3 & \dots & T_m & \\ \hline & 1 & 0 & 0 & \dots & 1 & M_1 \\ & 0 & 1 & 0 & \dots & & M_2 \\ & 1 & 0 & 1 & \dots & 1 & M_3 \\ & \dots & \dots & \dots & \dots & \dots & \dots \\ & 0 & 1 & 0 & \dots & 0 & M_k \end{array} \quad (4)$$

In the matrix (4)  $TM_{ij} = 1$  if the metric  $M_j$  is to be calculated for the test  $T_i$ , which, in turn, can be either “Pass” or “Fail” in the simplest case.

Further, the failures  $R = \{R_i \mid i \in (1 \dots n)\}$  affect to results of tests (observations)  $T$ . The relationship between sets  $T$  and  $R$  can be explained by the  $RT$  incidence matrix:

$$RT = \begin{array}{ccccc|c} & R_1 & R_2 & R_3 & \dots & R_n & \\ \hline & 0 & 1 & 0 & \dots & 1 & T_1 \\ & 1 & 1 & 0 & \dots & & T_2 \\ & 1 & 0 & 0 & \dots & 1 & T_3 \\ & \dots & \dots & \dots & \dots & \dots & \dots \\ & 0 & 1 & 1 & \dots & 0 & T_m \end{array} \quad (5)$$

In the matrix (5)  $RT_{ij} = 1$  if the failure  $R_i$  is one of the reasons which affects to the result of test  $T_j$ .

The analysis of the TD process and the logical connections found in it allow us to construct a diagram of causes and consequences in determining of UAS QM(Fig. 2).

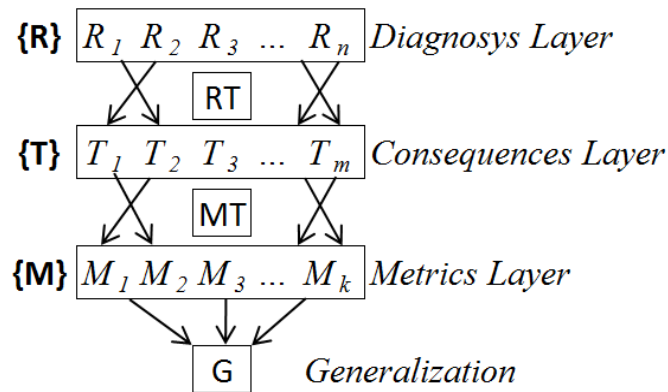


Fig. 2. Causes and consequences diagram of the TD procedure.

Thus, objects that participate in the UAS examining can be grouped logically into the diagnostic layer  $\{\mathbf{R}\}$ , the effects layer  $\{\mathbf{T}\}$ , and the layer of QM  $\{\mathbf{M}\}$ , as shown in Fig. 2. The matrixes (4), (5) are acting as interfaces between these layers.

In Fig. 2 also there is the node of generalization of quality metrics  $G$  which is not mandatory in terms of normative documents. It looks useful technically for ensuring the possibility of final result obtaining and it can be interpreted simply in process of results analysis. Traditionally, it is calculated as a weighted sum of metrics  $M_i$ :

$$G = \sum_{i=1}^k \alpha_i M_i, \quad (6)$$

where  $\alpha_i$  is a weight of metric  $M_i$ :

The sequence of determination of UAS quality indices according to the TD data corresponds to the following algorithm.

1. The  $\mathbf{R}$ ,  $\mathbf{T}$  and  $\mathbf{M}$  sets must be determined based on the UAS technical documentation and the existing regulations. Their elements determine the course and results of the UAS assessment.
2. The matrixes  $RT$  and  $TM$  are to be filled up. They determine the structure of causative relationships in the test procedure.
3. A test is conducted, during which:
  - a) TD is performed and by this way the results of measurements and failures observation  $\mathbf{R}$  become actualized;
  - b) the results of the  $\mathbf{T}$  test are determined, from which the  $X$ -sets for each metric of the set  $\mathbf{M}$  become actualized;
4. If necessary, the generalized index  $G$  is calculated according to the customer's test method.
5. To use the model in Fig. 2 as BNT, further it is necessary to define a priori probabilities for each of its objects. These a priori probabilities are determined either on the basis of the statistics of previous examinations, and/or on the basis of expert information.

The given algorithm has the following disadvantages:

1. The dimensions of  $RT$  and  $TM$  matrixes can be quite large:

$|RT| = |\mathbf{R}| \times |\mathbf{T}|$  and  $|TM| = |\mathbf{T}| \times |\mathbf{M}|$ . Their filling is a labor-intensive work, therefore its simplification is urgent.

2. The wording of p.3b above defines a slow consecutive procedure based on the  $RT$  and  $TM$  matrixes obtained in p.2. Such an approach does not pay attention to the possibility of a logical problem decomposition, taking into account the mutual different tests independence in the UAS structure, which belongs to different subsystems of it. The method described below shows how using BNT gets a solution to this problem.

3. Execution of p.5 of the above algorithm is a daunting task, since for each object it is necessary to determine a priori probabilities for the full range of common distribution of the probability of parent nodes. The situation may be much easier when:



- it is possible to determine the independence some objects from others in the model;
- when the objects of the model have a discrete distribution of values.

#### 4 Construction the BNT for the UAS Examination

The diagram in Fig. 2 corresponds to the deterministic process of determining UAS QM, while the purpose of this study is to improve the mentioned process with the use of existing causal relationships between layers of test objects (Fig. 2), which opens up the possibility to use a powerful apparatus [4] estimation of conditional probabilities (degrees of confidence) between them. This math is based on the notion of trust networks, whose interconnection of elements is based on the well-known Bayesian theorem.

BNT is a graphical, high-quality illustration of the interactions between the plurality of variables it simulates. The structure of the “casual” oriented graph can simulate the cause-and-effect structure of the simulated subject area, although this is not necessary. When BNT is casual, it provides useful, structured information about the interactions between variables and allows predicting the effects of external manipulations.

The distribution of common probabilities presented in the BNT is based on the so-called “subjectivist” definition of probability. Given new observations (test results), the subjective distribution of common probabilities at the vertices of the graph is updated using the well-known Bayes formula:

$$P(A|B) = \frac{P(B|A) \cdot P(A)}{P(B)} \quad (7)$$

where  $P(A|B)$  is probability of event  $A$  provided that event  $B$  occurred;

$P(B|A)$  – the likelihood of event  $B$  provided that event  $A$  occurred;

$P(A)$  – a priori probability of event  $A$ ;

$P(B)$  – complete (marginal) probability of event  $B$ .

The calculation  $P(B)$  is related to fairly voluminous computations by the general formula

$$p(B) = \int_{range\ A} p(B|A) \cdot p(A) \cdot dA, \quad (8)$$

or, in the case when the set  $A$  consists of a discrete set of values – by the formula

$$p(B) = \sum_{i=1}^n p(B|A_i) \cdot p(A_i).. \quad (9)$$

Let’s apply the above-mentioned method of constructing BNT for its creating in the case of analysis of the conditional examining procedure of UAS.

The examination procedure can be formally-logical imagined as a tuple

$$E = \langle \mathbf{R}, \mathbf{T}, \mathbf{M}, \mathbf{G} \rangle \quad (10)$$

in which:

- set  $\mathbf{R}$  – different kinds of failure, inconsistency and malfunction in UAS;

- set  $T$  – the consequences to which  $R$  leads. This may be:
  1. the results of tests that are specifically performed by the testers during the examination;
  2. symptoms that are directly observed;
- the set of  $M$  is the metric of UAS QM (formula (2));
- a generalized UAS quality index  $G$ .

These elements can be grouped according to the layers, as shown in Fig. 3.

### 5 Determination of the Relative Impact of UAS Examining's Factors for Improving the Examination Procedure

As noted in [8], the notion of conditional probability is not limited to the recalculation of the occurrence quantities some events, but means the mathematical dependence some random variables from others. That is why BNT in Fig. 4 can be considered as “a black box”. Let its inputs to be consistent with the actualization of objects from the diagnostic layer  $\{R\}$ , and with the variable  $G$  that is target function as well. The transfer function of the “black box” is formed by the set  $J$  of common probability distributions in BNT.

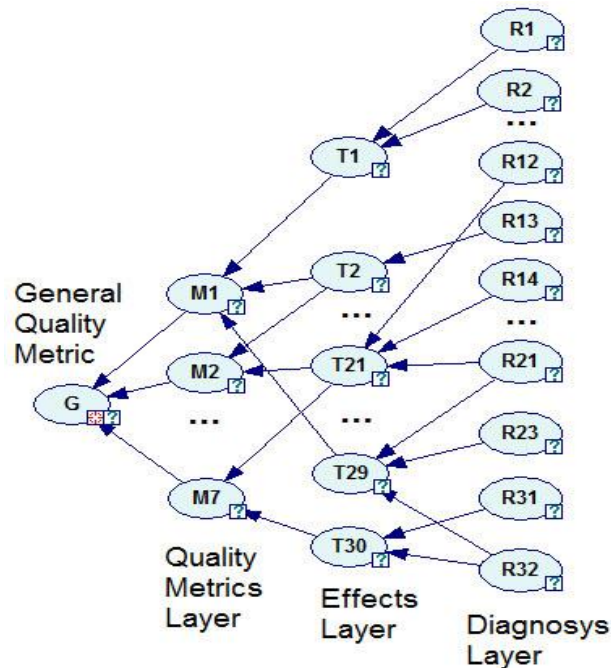
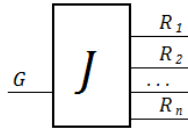


Fig. 3. Oriented graph F of the BNT for examining procedure E.



**Fig. 4.** BNT as “a black box”.

Mathematically it’s possible to show this as

$$G = G(J, R_1, R_2, \dots, R_n). \tag{11}$$

The relative influence of the inputs  $\{R\}$  to the formation of the value of the target function  $G$  can be estimated [10] by the values of partial derivatives

$$f_i = \frac{\partial G}{\partial R_i} \mid i \in (1..n), \tag{12}$$

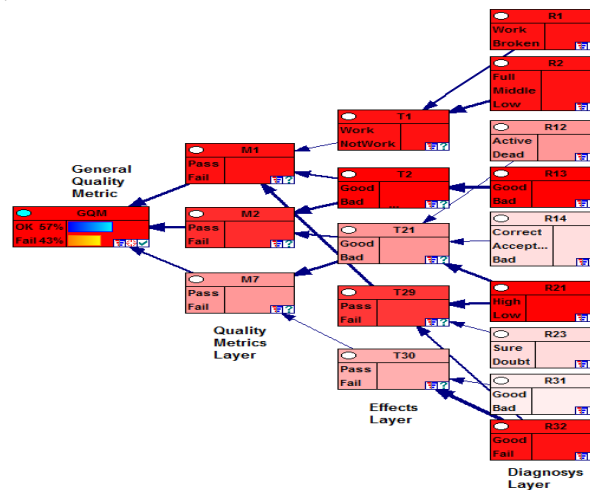
which in [10] have been called levels of influence (LI), or impact factors.

The calculation values  $f_i$  requires a numerical differentiation (11), which, as noted above, involves performing calculations of common probabilities. In the worst case these calculations have the computational complexity level of  $O(NP)$  [8]. To solve the problems the BNT BayesFusion GeNIe Modeler 2.3 [10] modeling application was used. The model which had been constructed in this application is shown in Fig. 3.

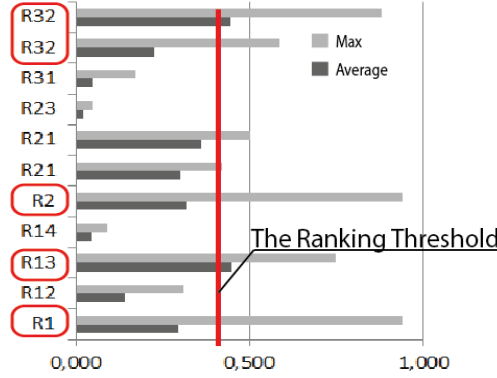
Further, according to the above goal of the study, we will define as the target node GQM (Fig.5).

After this application can estimate the degree of influence of other nodes, after which the graph of the model takes the view on Fig. 5.

A detailed level influence (LI) analysis was carried out using numerical estimates exported from the simulation environment. According to these data a diagram (Fig. 6) was constructed.



**Fig.5.** The analysis of model’s nodes impact factors to the target node.



**Fig. 6.** LI comparison and ranking for nodes.

Based on the diagrams given in Fig. 6, the ranking threshold  $T_R$  was selected. The nodes ranking of the primary layer of diagnosis as meaningful  $\mathbf{R}_m \subseteq \mathbf{R}$  and insignificant is performed by the condition:

$$\forall R \in \mathbf{R}_m: LI_R > T_R. \quad (13)$$

In our case  $\mathbf{R}_m = \{R_1, R_2, R_{13}, R_{32}\}$  was defined as meaningful.

After performing the described actions the model of Fig.8 can determine how the initial conditional probability  $p(GQM=OK) = 57\%$  changes in cases when each of the nodes  $R \in \mathbf{R}_m$  will alternately obtain the worst of the values specified in it. The simulation results are as follows.

$$\begin{aligned} p(GQM=OK|R_1=Broken) &= 23\%, \\ p(GQM=OK|R_2=Low) &= 23\%, \\ p(GQM=OK|R_{13}=Bad) &= 20\%, \\ p(GQM=OK|R_{32}=Fail) &= 26\%. \end{aligned}$$

The obtained results can be evaluated as inappropriate in terms of the success of the entire expertise. This allows you to build a testing strategy that performs the most critical tests. In the example above the number of needed tests may be reduced from 11 to 5 (45% of common number). Receiving negative results either on one of test, or on their combination, will mean stopping the redundant work of performing other inspections.

## 6 Conclusions

1. The proposed method for assessment UAS QM that use BNT in combination with technical diagnostic data had allowed to obtain information about the efficiency of the complex test in the early stages of its implementation. In real conditions this will allow to organize efficiently the examination process, reduce the time needed for its execution and reduce material spending.
2. Developed algorithms that use the BNT to determine UAS QM provide the definition which tests are expected to be implemented during the expertise up to the final

result. This opens the opportunity to determine the most efficient test which includes the only significant checks that give a reliable and fast result.

3. Bayesian trust network allows to quickly finding the most probable causes of test failures in the process of examining, localize their causes and quickly eliminate them, which is an important factor in accelerating the testing.
4. This study may be further developed in the direction of creating semi-automatic planning and testing systems using BNT for purpose of the determination the most effective strategy for UAS expertise.

## References

1. Valavanis, K.P., Vachtsevanos, G.J, (eds.): Handbook of Unmanned Aerial Vehicles. Springer Science+Business Media, Dordrecht (2015).
2. NASA-STD-8739.10. Electrical, Electronic, and Electromechanical (EEE) Parts Assurance Standard. Measurement System Identification: Metric/SI. NASA technical standard. National Aeronautics and Space Administration Approved: 2017-06-13 Washington, DC 20546-0001, 39 p. (2017).
3. Snooke, N.: Automated Failure Effect Analysis for PHM of UAV. In Valavanis, K.P., Vachtsevanos, G.J, (eds.) Handbook of Unmanned Aerial Vehicles. Springer Science+Business Media, Dordrecht (2015).
4. Azzimonti , L., Corani,G.: Hierarchical estimation of parameters in Bayesian networks. Computational Statistics and Data Analysis 137, 67-91 (2019).
5. Icen, D., Ersel, D.: A new approach for probability calculation of fuzzy events in Bayesian Networks. International Journal of Approximate Reasoning, vol.108, 76-88 (2019).
6. ISO 9001:2015. Quality Management Principles.
7. AQAP-2210:2015. NATO Supplementary Software Quality Assurance Requirements to AQAP-2110 or 2310.
8. Kjaerulff, U., Madsen, A.: Probabilistic Networks. In Bayesian Networks and Influence Diagrams: A Guide to Construction and Analysis. Information Science and Statistics, vol 22, Springer, New York, NY (2013).
9. Sahoo, P.: Probability And Mathematical Statistics. University of Louisville, USA, Louisville (2013).
10. GeNIe Modeler. User Manual. Version 2.3.R4. BayesFusion, LLC (2019).

# Computer Simulation of Neural Networks Using Spreadsheets: Dr. Anderson, Welcome Back

Serhiy Semerikov<sup>1</sup>[0000-0003-0789-0272], Illia Teplytskyi<sup>1</sup>,  
Yuliia Yechkalo<sup>2</sup>[0000-0002-0164-8365], Oksana Markova<sup>2</sup>[0000-0002-5236-6640],  
Vladimir Soloviev<sup>1</sup>[0000-0002-4945-202X] and Arnold Kiv<sup>3</sup>

<sup>1</sup> Kryvyi Rih State Pedagogical University, 54, Gagarina Ave., Kryvyi Rih, 50086, Ukraine  
{semerikov, vnsoloviev2016}@gmail.com

<sup>2</sup> Kryvyi Rih National University, 11, Vitali Matusevich St., Kryvyi Rih, 50027, Ukraine  
uliaechk@gmail.com, markova@mathinfo.ccjournals.eu

<sup>3</sup> Ben-Gurion University of the Negev, Beer Sheba, Israel  
kiv@bgu.ac.il

**Abstract.** The authors of the given article continue the series presented by the 2018 paper “Computer Simulation of Neural Networks Using Spreadsheets: The Dawn of the Age of Camelot”. This time, they consider mathematical informatics as the basis of higher engineering education fundamentalization. Mathematical informatics deals with smart simulation, information security, long-term data storage and big data management, artificial intelligence systems, etc. The authors suggest studying basic principles of mathematical informatics by applying cloud-oriented means of various levels including those traditionally considered supplementary – spreadsheets. The article considers ways of building neural network models in cloud-oriented spreadsheets, Google Sheets. The model is based on the problem of classifying multi-dimensional data provided in “The Use of Multiple Measurements in Taxonomic Problems” by R. A. Fisher. Edgar Anderson’s role in collecting and preparing the data in the 1920s-1930s is discussed as well as some peculiarities of data selection. There are presented data on the method of multi-dimensional data presentation in the form of an ideograph developed by Anderson and considered one of the first efficient ways of data visualization.

**Keywords:** Anderson’s Iris, cloud-based learning tools, computer simulation, mathematical informatics, neural networks, spreadsheets.

## 1 Introduction

The Fourth Industrial Revolution (Industry 4.0) actualized by the founder of the World Economic Forum, Klaus Schwab, has become a system-related challenge for the scientific community [15]. Industry 4.0 is primarily characterized by evolution and convergence of nano-, bio-, information and cognitive technologies to enhance high quality transformations in economic, social, cultural and humanitarian spheres. Professionals dealing with development and introduction of the sixth technological

paradigm technologies determine to a great extent whether our country is able to ride the wave of Industry 4.0 innovations. Therefore, extensive implementation of information and communication technologies (ICT) is a top priority of Ukraine's higher education updating in order to form a professionally competent specialist able to ensure the country's innovative development.

According to the Decree of the Cabinet of Ministers of Ukraine "Certain issues of specifying medium-term priorities of the national-level innovative activity for 2017-2021" (2016) [7], developing modern ICT and robotics, particularly cloud technologies, computer training systems and technologies of *mathematical informatics* (intellectual simulation, informational security, long-term data storage and "big data" management, artificial intelligence systems) are nationally and socially important directions of the innovative activity [10; 12].

The Decree of the Cabinet of Ministers of Ukraine "Certain issues of specifying medium-term priorities of the sectoral-level innovative activity for 2017-2021" (2017) [8] specifies that these directions accompanied by smart web-technologies and cloud computing make the basis for creating and defining themes for scientific researches and technical (experimental) developments as well as for forming the state order of training ICT specialists.

## 2 Literature Review and Problem Statement

Mathematical informatics is treated in two basic aspects:

### 1. *as an area of*

- theoretical research (mathematical models and means are used to simulate and investigate information processes in various areas of human activity);
- applied research (information systems and technologies are used to solve application-oriented problems).

### 2. *as a subject* which

- studies basic models, methods and algorithms of solving the problems in intellectualization of information systems;
- considers the issues of applying information models and information technologies of their study.

At the same time, the review in [9] ] has revealed that in spite of the significant role of mathematical informatics in the computer sciences system, its models and methods are not applied to computer engineering and software engineering at Ukraine's higher educational institutions in a consistent manner.

In [11; 19; 23], the systematic training of students of technical universities (first of all, IT-students) in mathematical informatics is substantiated and its leading methods are determined. Introduction of mathematical informatics into university curricula is theoretically based on fundamentalization of professional training as a means of overcoming a gap between the training content and technological advance [24].

Future training in mathematical informatics results in IT specialists' ability to modify available and elaborate new information technologies based on models and methods of mathematical informatics in order to enhance the country's innovative development.

In [10] the role of neural network simulation in the training content of the special course "Foundations of Mathematical Informatics" is discussed. The course is developed for students of technical universities (future IT-specialists) and aimed at breaking a gap between theoretic computer science and its practical application to software, system and computing engineering. CoCalc is justified as a training tool for mathematical informatics in general and neural network modeling in particular. The elements of CoCalc techniques for studying the topic "Neural network and pattern recognition" within the special course "Foundations of Mathematical Informatics" are shown.

The authors of [16] distinguish basic approaches to solving the problem of network computer simulation training in the spreadsheet environment, joint application of spreadsheets and tools of neural network simulation, application of third-party add-ins to spreadsheets, development of macros using the embedded languages of spreadsheets; use of standard spreadsheet add-ins for non-linear optimization, creation of neural networks in the spreadsheet environment without add-ins and macros.

In [17; 18], there are opportunities for applying spreadsheets to introducing essentials of machine learning [13] at secondary and higher school as well as some elements of their application to solving problems of pattern classification.

Thus, using spreadsheets as a tool for teaching basics of machine learning creates conditions for early and simultaneously deeper mastering of corresponding models and methods of mathematical informatics [2].

### 3 The Aim and Objectives of the Study

Therefore, the *aim of the study* is to develop certain components of the methods of using electronic spreadsheets as a training tool for neural network simulation in the special course "Foundations of Mathematical Informatics".

To accomplish the set goal, the following tasks are to be solved:

1. substantiation of chosen sets of data to develop a model;
2. development of a demonstration model of an artificial neural network using cloud-oriented spreadsheets.

### 4 Edgar Anderson and His "Fisher's Iris Data Set" (1936)

Edgar Shannon Anderson (November 9, 1897 – June 18, 1969) was born in Forestville, New York (Fig. 1). According to George Ledyard Stebbins, from an early age he exhibited both superior intelligence and a great interest in plants, particularly in cultivating them and watching them grow [20, p. 4].





**Fig. 1.** Edgar Anderson's portrait and signature

He went to Michigan Agricultural College at the age of sixteen, just before his seventeenth birthday, knowing already that he wanted to be a botanist. After completing his degree, he accepted a graduate position at the Bussey Institution of Harvard University. After leaving Harvard with his doctor's degree in 1922, Anderson spent nine years at the Missouri Botanical Garden, where he was a geneticist and Director of the Henry Shaw School of Gardening; at the same time he was Assistant Professor, later Associate Professor, of Botany at Washington University in St. Louis. During this period, he developed the beginnings of his highly original and effective methods for looking at and recording variation in plant populations, as well as his keen interest in the needs and progress, both scientific and personal, of students in botany. His training in genetics had given him habits of precision and mathematical accuracy in observing and recording variation in natural populations that were entirely foreign to the taxonomists of that period [20, p. 5].

Through contacts with Jesse Greenman, Curator of the Garden Herbarium, he became aware of the enormous complexity and extent of the variation present in any large plant genus and of the need for understanding the origin of species as a major step in evolution. On extensive field trips he began to realize that a great amount of genetic variation exists within most natural populations of plants. This realization led him to the conclusion that "if we are to learn anything about the ultimate nature of species we must reduce the problem to the simplest terms and study a few easily recognized, well differentiated species" [4, p. 243].

He first selected *Iris versicolor*, the common blue flag, because he believed it to be clearly defined, and it was common and easily observed. Initially, this appeared to be a mistaken choice, since he soon found that *Iris versicolor* of the taxonomic manuals was actually two species, which, after preliminary analysis, he could easily tell apart. He then set himself the task of finding out, by a careful analysis of populations throughout

their geographic areas, how one of these species could have evolved from the other. He recorded several morphological characters in more than 2,000 individuals belonging to 100 populations, data far more extensive than those that any botanist had yet obtained on a single species.

In order to enable these data to be easily visualized and compared, he constructed the first of his highly original and extremely useful series of simplified diagrams or ideographs (Fig. 2). By examining them, he reached the conclusion that the variation within each of his two species was of another order from the differences between them; no population of one species could be imagined as the beginning of a course of evolution toward the other. He therefore concluded that speciation in this example was not a continuation of the variation that gave rise to differences between populations of one species, and started to look for other ways in which it could have taken place. The current literature offered a possible explanation: hybridization followed by chromosome doubling to produce a fertile, stable, true-breeding amphidiploid. To apply this concept to *Iris*, he had to find a third species that would provide an alternate parent for one of those studied. Going to the herbarium, he found it: an undescribed variety of *Iris setosa*, native to Alaska.

All of his data, including counts of chromosome numbers, agreed with the hypothesis that *Iris versicolor* of northeastern North America had arisen as an amphiploid, one parent being *Iris virginica* of the Mississippi Valley and the Southeast Coast and the other being *Iris setosa* var. interior of the Yukon Valley, Alaska. This was one of the earliest demonstrations that a plant species can evolve by hybridization accompanied or followed by chromosome doubling. Moreover, it was the first one to show that amphiploid or allopolyploid species could be used to support hypotheses about previous distribution of species.

Anderson's research into *Iris* resulted in all the techniques in his later successful work, namely:

1. careful examination of individual characteristics of plants growing in nature and progeny raised in the garden;
2. reduction of this variation to easily visualized, simple terms by means of scatter diagrams and ideographs;
3. extrapolation from a putative parental species and supposed hybrids to reconstruct the alternative parent;
4. development of testable hypotheses by synthesizing data from every possible source.

The *Iris* research was Anderson's chief accomplishment during his first period at the Missouri Botanical Garden. Toward the end of this period, in 1929-1930, he received a National Research Fellowship to study in England. There he was guided chiefly by geneticist J. B. S. Haldane, but he also studied cytology under C. D. Darlington and statistics with R. A. Fisher. Haldane introduced him to the mutants of *Primula sinensis*, which he analyzed in collaboration with Dorothea De Winton. Their joint research was the first effort in plant material to relate pleiotropic gene action to growth processes.

In 1931 Anderson went to Harvard, where he stayed until 1935, as an arborist at the Arnold Arboretum. He returned to the Missouri Botanical Garden in 1935 and remained there for the rest of his life. Returning to his study of the genus *Iris*, he and several

students analyzed a complex variation pattern of populations found in the Mississippi delta region [3].

Anderson integrated his new experience with past memories, popular accounts of his methods of research, and his general philosophy of life in the book “Plants, Man and Life” [2] published in 1952. It is a combination of scientific knowledge, folklore of Latin American and other countries, and Anderson’s comments on early herbalists and the habits of taxonomists and botany professors, plus a bit of philosophy. One of his chief contributions to plant science, the pictorialized scatter diagram, is presented for the first time in its final form in a chapter entitled, characteristically, “How to Measure an Avocado” (Fig. 2).

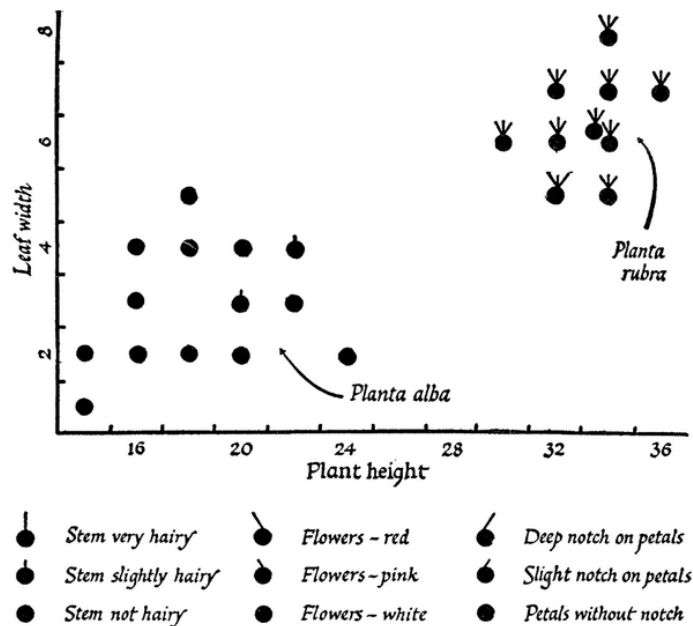


Fig. 2. Anderson’s pictorialized scatter diagram [2, p. 97]

In 1954 Anderson became Director of the Missouri Botanical Garden, but he found full-time administration frustrating and in 1957 resigned and resumed his career of teaching and research. During the 1960s he was plagued by illness, and his principal contributions during that period were a steady flow of popular articles on trees, shrubs, and other plants of the garden. He retired officially in 1967.

Anderson’s article of 1936 [1] was his last work dedicated to the problem of Iris origin and classification. In his introduction to the article, Anderson not only expressed his gratitude to his English teachers, but also directly indicated that “Dr. Wright, Prof. J. B. S. Haldane, and Dr. R. A. Fisher have greatly furthered the final analysis of the data, though they are in no way responsible for the imperfections of the work or of its presentation.” [1, p. 458].

In 1936, Sir Ronald Aylmer Fisher published the article “The Use of Multiple Measurements in Taxonomic Problems” indicating that “Table I shows measurements of the flowers of fifty plants each of the two species *Iris setosa* and *I. versicolor*, found growing together in the same colony and measured by Dr E. Anderson, to whom I am indebted for the use of the data” [6, p. 179-180]. Fisher’s article contained only three references two of which to Anderson’s works – that of 1935 [3] and that of [1] marked with “(in the Press)”. In 1936, Fisher was not the member of the editorial board of “Annals of the Missouri Botanical Garden”. The only way of his being aware of Anderson’s article [1], was their personal correspondence.

The set of data used by Fisher and collected by Anderson was introduced as “Iris flower data set” (or “Iris data set” and “Iris data”). The phrase “Fisher’s Iris data set” traditionally expresses Fisher’s role as the founder of linear discriminant analysis, but not the authorship of the data set.

Although Anderson never published these data, he described [3] how he collected information on irises: “For some years I have been studying variation in irises but never before have I had the good fortune to meet such quantities of material for observation. On the simple assumption that if current theories are true, one should be able to find evidence of continuing evolution in any group of plants, I have been going around the world looking as sharply as possible at variation in irises. On any theory of evolution the differences between individuals get somehow built up, in time, into the differences between species. That is to say that by one process or another the differences which exist between one plant of *Iris versicolor* and its neighbor are compounded into the greater difference which distinguishes *Iris versicolor* from *Iris setosa canadensis*. It is a convenient theory and if it is true, we should be able to find the beginnings of such a compounding going on in our present day species. For that reason I have studied such irises as I could get to see, in as great detail as possible, measuring iris standard after iris standard and iris fall after iris fall, sitting squat-legged with record book and ruler in mountain meadows, in cypress swamps, on lake beaches, and in English parks. The result is still merely a ten year’s harvest of dry statistics, only partially winnowed and just beginning to shape itself into generalizations which permit of summarization and the building of a few new theories to test by other means.

I have found no other opportunity quite like the field from De Verte to Trois Pistoles. There for mile after mile one could gather irises at will and assemble for comparison one hundred full-blown flowers of *Iris versicolor* and of *Iris setosa canadensis*, each from a different plant, but all from the same pasture, and picked on the same day and measured at the same time by the same person with the same apparatus. The result is, to ordinary eyes, a few pages of singularly dry statistics, but to the biostatistician a juicy morsel quite worth looking ten years to find.

After which rhapsody on the beauty of variation it must immediately be emphasized that *Iris setosa canadensis* varies but little in comparison with our other native blue flags. *Iris versicolor* in any New England pastures may produce ground colors all the way from mauve to blue and with hafts white or greenish or even sometimes quite a bright yellow at the juncture with the blade. *Iris setosa canadensis* by contrast is prevalingly uniform, its customary blue grey occasionally becoming a little lighter or a little darker or even a little more towards the purple, and its tiny petals producing odd

variants in form and pattern, but presenting on the whole only a fraction of the variability of *Iris versicolor* from the same pasture.

The reasons for this uniformity are not far to seek. Its lower chromosome number is one, but a discussion of that and its bearings on the whole problem would be a treatise in itself. More important probably is the fact that by geological and biological evidence, *Iris setosa canadensis* is most certainly a remnant, a relict [*sic*] of what was before the glacial period a species widely spread in northern North America.

If we take a map and plot thereon all known occurrences of *Iris setosa* and *Iris setosa canadensis*, we shall find the former growing over a large area at the northwest corner of the continent, and the latter clustering in a fairly restricted circle about the Gulf of St. Lawrence, while in the great intervening stretch of territory, none of these irises has been collected. This is a characteristic distribution for plants which were almost exterminated from eastern North America by the continental ice sheet, but while [*sic*] managed to persist in the unglaciated areas about the Gulf of St. Lawrence from which center they have later spread. In Alaska the species itself, *Iris setosa*, is apparently quite as variable as our other American irises.”

So, we should pay tribute to Edgar Anderson by naming this data set after him – Anderson’s Iris data set.

## 5 Model development

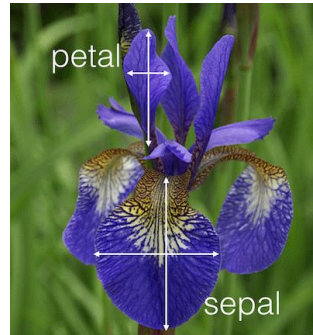
As indicated in [10], the special course “Foundations of Mathematical Informatics” final control of knowledge is a credit by the presentation of individual education and research projects on the artificial neural networks built by using CoCalc. Students can be offered to use cloud-based spreadsheets, Google Sheets, with the Solver additional cloud-based component (add-in) which is similar to “Solver” in Excel Online.

Let us consider the corresponding application method by taking a multi-dimensional data set (Anderson’s Iris data set) to solve the pattern classification problem. Anderson’s Iris is composed of data on 150 measurements of three Iris species (Fig. 3) – *Iris setosa*, *Iris virginica* and *Iris versicolor* – including 50 measurements for each species.

There were measured four features (Fig. 4): sepal length (SL), sepal width (SW), petal length (PL), and petal width (PW).



Fig. 3. Anderson’s Irises



**Fig. 4.** Measurement features of Anderson's Irises

To draw a grounded conclusion on the Iris type, we build a three-layered neural network with the following architecture (Fig. 5):

- the input layer is a four-dimensional arithmetical vector  $(x_1, x_2, x_3, x_4)$  the components of which are corresponding measured features of Anderson's Irises (SL, SW, PL, PW) normalized according to the network activation function;
- the hidden layer has dimension 9 (the minimal required number according to Kolmogorov–Arnold representation theorem) and is described by the vector  $(h_1, h_2, h_3, h_4, h_5, h_6, h_7, h_8, h_9)$ ;
- the output layer is a three-dimensional arithmetical vector  $(y_1, y_2, y_3)$  the components of which are probabilities indicating the correspondence of the data set to one of the three Iris types.

The bias neuron equal to 1 (marked red in Fig. 5) is added to the neurons of the input and hidden layers. The bias neurons are noted for not having synapses so they cannot be located in the output layer.

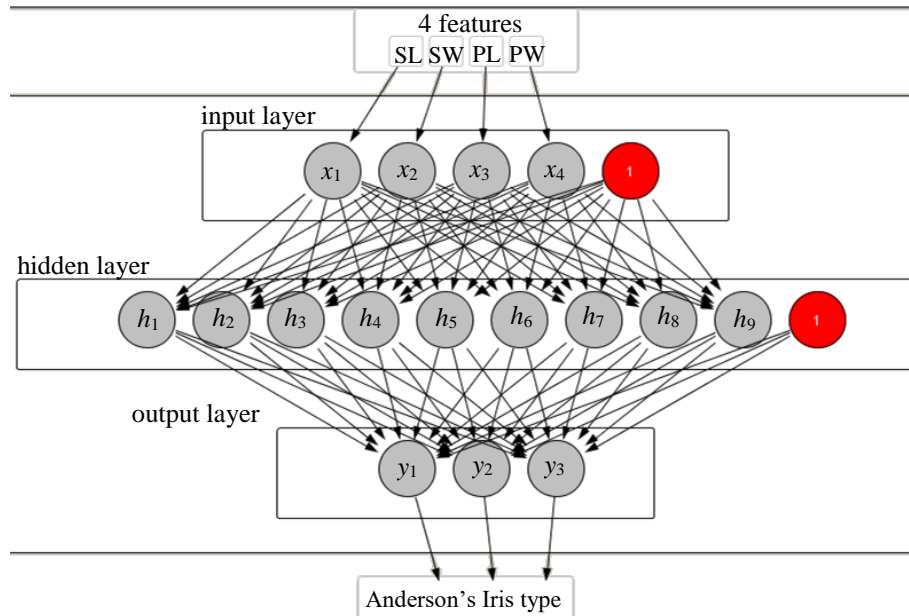
Let us first introduce Anderson's Irises into spreadsheets with the following values of cells: A1 is *Iris Data*, A2 is SL, B2 is SW, C2 is PL, D2 is PW, E2 is *Species*.

The table cells A3:E152 include Anderson's Irises (Fig. 6).

We cannot input the data of the given set into the input layer as the value of the four characteristics is beyond the range limits  $[0; 1]$ . The next step is normalization of columns A, B, C and D to meet the given range and coding of Iris types from column E.

Each Iris type is coded by the three-dimensional arithmetical vector: for *i*-Iris (Iris setosa is 1, Iris versicolor is 2, Iris virginica is 3) we set the *i*-th component in 1, and the other ones – in 0. To do this, we introduce the following values into the cells: G1 is encoding, G2 is setosa, H2 is versicolor, I2 is virginica, G3 is `=if($E3=G$2,1,0)`.

Next, we copy the formula from the cell G3 to the range G3:I152 and obtain the following model codes for the three Iris types: for Iris setosa – (1, 0, 0), for Iris virginica – (0, 0, 1) and for Iris versicolor – (0, 1, 0).



**Fig. 5.** Architecture of the neural network to solve the problem of Anderson's Iris classification

	A	B	C	D	E
1	<i>Iris Data</i>				
2	<b>SL</b>	<b>SW</b>	<b>PL</b>	<b>PW</b>	<b>Species</b>
3	5.10	3.50	1.40	0.20	<i>setosa</i>
4	4.90	3.00	1.40	0.20	<i>setosa</i>
5	4.70	3.20	1.30	0.20	<i>setosa</i>
6	4.60	3.10	1.50	0.20	<i>setosa</i>
7	5.00	3.60	1.40	0.20	<i>setosa</i>
8	5.40	3.90	1.70	0.40	<i>setosa</i>

**Fig. 6.** The fragment of the spreadsheet of Anderson's Irises

Each column is normalized separately. To perform this, we find minimum and maximum values by introducing the following values: E154 is min, E155 is max, A154 is =min(A3:A152), A155 is =max(A3:A152).

We apply the cells A154:A155 to the range B154:D155 and introduce the following values into the cells: K1 is normalization, K2 is  $x_1$ , L2 is  $x_2$ , M2 is  $x_3$ , N2 is  $x_4$ , K3 is = (A3-A\$154) / (A\$155-A\$154).

The latter formula is applied to the range K3:N152. Its essence is explained by:

$$\text{normalization} = \frac{\text{value} - \text{min}}{\text{max} - \text{min}}$$

This approach results in the minimum value normalized to 0, while the maximum one – to 1.

According to the chosen architecture, we add the bias neuron to the four neurons of the input layer by introducing its name ( $x_5$ ) into the cell O2 and its value (1) into the range O3:O152. On this stage, the input layer is formed as  $x_1, x_2, x_3, x_4, x_5$ .

The next step includes transmission of a signal from the input layer to the hidden one of the neural network. We denote the weight coefficient of the synapse connecting the neuron  $x_i$  ( $i = 1, 2, 3, 4, 5$ ) of the input layer with the neuron  $h_j$  ( $j = 1, 2, \dots, 9$ ) of the hidden layer by  $w^{jh}_{ij}$ , while the weight coefficient connecting the neuron  $h_j$  of the hidden layer with the neuron  $y_k$  ( $k = 1, 2, 3$ ) of the input layer is denoted by  $w^{ky}_{jk}$ . In this case, the force of the signal coming to the neuron  $h_j$  of the hidden layer is determined as a scalar product of signal values on the input signals and corresponding weight coefficients. To determine a signal going further to the output layer, we apply the logistic function of activation  $f(S) = 1/(1+e^{-S})$ , where  $S$  is a scalar product. The formulae for determining the signals on the hidden and output layers will look like:

$$h_j = f\left(\sum_{i=1}^{4+1} x_i w^{jh}_{ij}\right), y_k = f\left(\sum_{j=1}^{9+1} x_j w^{ky}_{jk}\right).$$

Accordingly, two matrices should be created. The matrix  $w^{jh}$  of  $5 \times 9$  contains weight coefficients connecting five neurons of the input layer (the first four contain normalized characteristics of Anderson's Irises, while the fifth one is the bias neuron) with the neurons of the hidden layer. The matrix  $w^{ky}$  of  $10 \times 3$  contains weight coefficients connecting ten neurons of the hidden layer (nine of which are calculated and the tenth one is the bias neuron) with the neurons of the output layer. For the "untaught" neural network, initial values of the weight coefficients can be set either randomly or left undetermined or equal to zero. To realize the latter, we fill the cells with the following values: R1 is  $w^{jh}$ , Q2 is input/hidden, R2 is 1, S2 is =R2+1, Q3 is 1, Q4 is =Q3+1, R3 is 0, R9 is  $w^{ky}$ , Q10 is hidden/output, R10 is 1, S10 is =R10+1, Q11 is 1, Q12 is =Q11+1, R11 is 0.

To create the matrices, we should copy the cells R3 into the range R3:Z7, R11 – into R11:T20, S2 – into T2:Z2, Q4 – into Q5:Q7, S10 – into T10, Q12 – into Q13:Q20 (Fig. 7).

To calculate the scalar product of the vector row of the input layer values by the matrix vector-column of the weight coefficients  $w^{jh}$ , we should apply the matrix multiplication function: AB1 is calculate the hidden layer, AB2 is  $h_1$ , AC2 is  $h_2$ , AD2 is  $h_3$ , AE2 is  $h_4$ , AF2 is  $h_5$ , AG2 is  $h_6$ , AH2 is  $h_7$ , AI2 is  $h_8$ , AJ2 is  $h_9$ , AK2 is  $h_{10}$ , AB3 is  $=1/(1+\exp(-\text{mmult}(\$K3:\$O3, R\$3:R\$7)))$ , AK3 is 1.

Next, we copy the cell AK3 into the range AK4:AK152, while AB3 – into AB3:AJ152.

Considering the fact that all the matrix elements of the weight coefficients  $w^{jh}$  equal to zero, after duplicating the formulae, the calculated elements of the hidden layer will be equal to 0.5.

In the same way, we calculate the output layer elements: AM1 is calculate the output layer, AM2 is  $y_1$ , AN2 is  $y_2$ , AO2 is  $y_3$ , AM3 is  $=1/(1+\exp(-\text{mmult}(\$AB3:\$AK3, R\$11:R\$20)))$ .



fx = (A3-A\$154)/(A\$155-A\$154)																				
	G	H	I	J	K	L	M	N	O	P	Q	R	S	T	U	V	W	X	Y	Z
1	encoding			normalization					wxh											
2	setosa	versicolor	virginica	x1	x2	x3	x4	x5	input/hidden											
3	1	0	0	0.2222	0.6250	0.0678	0.0417	1			1	0.00	0.00	0.00	0.00	0.00	0.00	0.00	0.00	0.00
4	1	0	0	0.1667	0.4167	0.0678	0.0417	1			2	0.00	0.00	0.00	0.00	0.00	0.00	0.00	0.00	0.00
5	1	0	0	0.1111	0.5000	0.0508	0.0417	1			3	0.00	0.00	0.00	0.00	0.00	0.00	0.00	0.00	0.00
6	1	0	0	0.0833	0.4583	0.0847	0.0417	1			4	0.00	0.00	0.00	0.00	0.00	0.00	0.00	0.00	0.00
7	1	0	0	0.1944	0.6667	0.0678	0.0417	1			5	0.00	0.00	0.00	0.00	0.00	0.00	0.00	0.00	0.00
8	1	0	0	0.3056	0.7917	0.1186	0.1250	1												
9	1	0	0	0.0833	0.5833	0.0678	0.0833	1												
10	1	0	0	0.1944	0.5833	0.0847	0.0417	1	hidden/output											
11	1	0	0	0.0278	0.3750	0.0678	0.0417	1			1	0.00	0.00	0.00						
12	1	0	0	0.1667	0.4583	0.0847	0.0000	1			2	0.00	0.00	0.00						
13	1	0	0	0.3056	0.7083	0.0847	0.0417	1			3	0.00	0.00	0.00						
14	1	0	0	0.1389	0.5833	0.1017	0.0417	1			4	0.00	0.00	0.00						
15	1	0	0	0.1389	0.4167	0.0678	0.0000	1			5	0.00	0.00	0.00						
16	1	0	0	0.0000	0.4167	0.0169	0.0000	1			6	0.00	0.00	0.00						
17	1	0	0	0.4167	0.8333	0.0339	0.0417	1			7	0.00	0.00	0.00						
18	1	0	0	0.3889	1.0000	0.0847	0.1250	1			8	0.00	0.00	0.00						
19	1	0	0	0.3056	0.7917	0.0508	0.1250	1			9	0.00	0.00	0.00						
20	1	0	0	0.2222	0.6250	0.0678	0.0833	1			10	0.00	0.00	0.00						

Fig. 7. The fragment of the spreadsheet after coding and normalization of the output data and creation of the matrices of the weight coefficients

Next, we copy the cell AM3 to the range AM3:AO152 (Fig. 8).

fx = 1/(1+exp(-mmult(\$AB3:\$AK3,\$S\$11:\$S\$20)))															
	AB	AC	AD	AE	AF	AG	AH	AI	AJ	AK	AL	AM	AN	AO	
1	calculate the hidden layer										calculate the output layer				
2	h1	h2	h3	h4	h5	h6	h7	h8	h9	h10	y1	y2	y3		
3	0.5000	0.5000	0.5000	0.5000	0.5000	0.5000	0.5000	0.5000	0.5000	0.5000	1	0.5000	0.5000	0.5000	
4	0.5000	0.5000	0.5000	0.5000	0.5000	0.5000	0.5000	0.5000	0.5000	0.5000	1	0.5000	0.5000	0.5000	

Fig. 8. The fragment of the spreadsheet of calculating the hidden and output layers with initial values of the weight coefficients

Neural network training is performed by varying weight coefficients so that with each training step the difference between the calculated values of the output layer and the desired (reference ones) reduces. To solve the problem, the three-dimensional vectors resulted from coding of the three Iris types are reference.

To find the difference between the calculated and the reference output vectors we apply the Euclidean distance: AQ2 is distance, AR2 is sum of distances, AQ3 is  $=\text{sqrt}((AM3-G3)^2+(AN3-H3)^2+(AO3-I3)^2)$ , AR3 is  $=\text{sum}(AQ3:AQ152)$ .

Next, we copy the cell AQ3 to the range AQ4:AQ152. The cell AR3 contains general deviation of the calculated output vectors from the reference ones.

Under this approach, the neural network training can be treated as an optimization problem in which the target function (the sum of distances in the cell AR3) will be minimized by varying the matrix weight coefficients  $w^{xh}$  (the range R3:Z7) and  $w^{hy}$  (the range R11:T20). To solve this problem, application of cloud-oriented spreadsheets (Google Sheets) is not enough and it is necessary to install an additional cloud-oriented component (add-in) Solver.

Adjustment of the add-in Solver to solve the set goal: the target function (Set Objective) is minimized (To: Min) by changing the values (By Changing) of the matrix

weight coefficients in the range (Subject To) from  $-10$  to  $+10$  by one of the optimization methods (Solving Method).

To reduce the total distances, the actions with Solver can be done repeatedly as it is expedient to experiment with combination of various optimization methods by changing the variation limits of the weight coefficients. It is not necessary to try to reduce the value of the total distances to zero as this can be a greater (quite smaller) value (Fig. 9).

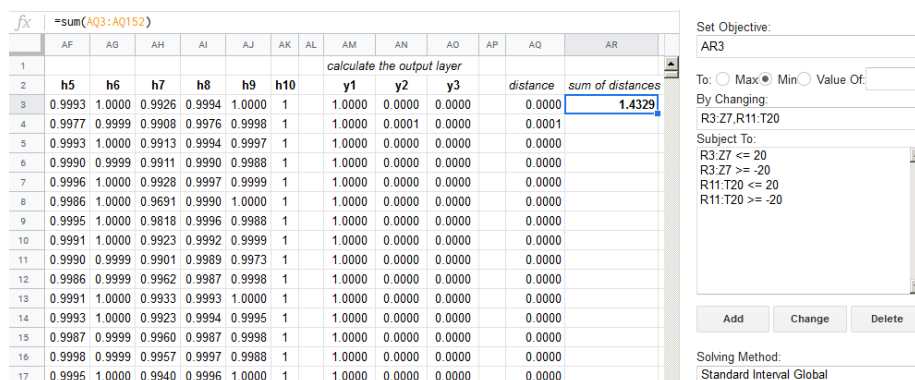


Fig. 9. Optimization results

On the assumption of the chosen coding method, the output vector actually contains three probabilities:  $y_i$  denotes the probability of the given sample being the  $i$ -type Iris, where  $i = 1$  for Iris setosa, 2 for Iris versicolor and 3 for Iris virginica. Then, to find out which Iris type describes the input vector (SL, SW, PL, PW), the most probable component should be determined.

To do this, we fill the cells in the following way: AT2 is Calculated Iris species, AT3 is `=if(max(AM3:A03)=AM3,$G$2,if(max(AM3:A03)=AN3,$H$2,$I$2))`, AU3 is `=if(AT3=E3,"right!","wrong")`.

Next, the range AT3:AU3 is copied to the range AT4:AU152.

The obtained result enables us to visualize pattern recognition simulated in spreadsheets. The built model will be considered relevant in all 150 cases, the column AU contains the value "right!".

To check the limits of the built model application, we try to input the vector not coinciding with any reference input vector. For this, we copy the table row 152 to 158 and delete the content of the cells E158:I158, AQ158, AU158. We introduce averaged values borrowed from the description of Iris versicolor in the article by Anderson [11, p. 463]: 5.50, 2.75, 3.50 and 1.25. The reference values  $x_1 = 0.3333$ ,  $x_2 = 0.3125$ ,  $x_3 = 0.4237$ ,  $x_4 = 0.4792$  are conveyed to the input layer, while on the hidden layer there are calculated  $h_1 = 0.0206$ ,  $h_2 = 0.4419$ ,  $h_3 = 0.0005$ ,  $h_4 = 0.0001$ ,  $h_5 = 0.9993$ ,  $h_6 = 0.9993$ ,  $h_7 = 0.0001$ ,  $h_8 = 0.0288$ ,  $h_9 = 0.9991$  and the values of the output layer  $y_1 = 0.0000$ ,  $y_2 = 1.0000$ ,  $y_3 = 0.0000$ . As the maximum value of the output layer 1.0000 corresponds to the other Iris type, we can conclude that Iris versicolor is identified.

## 6 Conclusions

1. Edgar Anderson appeared to be not a simple botanist whose data were the basis for Fisher's known method. Anderson's Irises resulted from his long experience of working out relevant models to describe changes in specific populations by means of a limited number of characteristics. Yet, Anderson had also coped with the opposite problem of building simple multi-dimensional data interpretation 40 years before Chernoff faces appeared [5].
2. The described methods of applying cloud-oriented spreadsheets as a tools for training mathematical informatics can enable solution of all basic problems of neural network simulation. The only limitation is not so much the volume of a spreadsheet as the memory space and the speed of the device processing it. In the special course projects if the limitation is overcome, this becomes a stimulus for replacing the simulation environment by a more relevant one [22].
3. The further research is the Dawn of the Age of Camelot: from Donald Hebb to Seymour Papert [17].

## References

1. Anderson E.: The Species Problem in Iris. *Annals of the Missouri Botanical Garden*. **23**(3), 457–469+471–483+485–501+503–509 (1936). doi:10.2307/2394164.
2. Anderson, E.: *Plants, Man and Life*. University of California Press, Boston (1952)
3. Anderson, E.: The irises of the Gaspé Peninsula. *Bulletin of the American Iris Society*. **59**, 2–5 (1935)
4. Anderson, E.: The Problem of Species in the Northern Blue Flags, *Iris versicolor* L. and *Iris virginica* L. *Annals of the Missouri Botanical Garden*. **15**(3), 241–332 (1928). doi:10.2307/2394087
5. Chernoff, H.: The Use of Faces to Represent Points in K-Dimensional Space Graphically. *Journal of the American Statistical Association*. **68**(342), 361–368 (1973)
6. Fisher, R.A.: The Use of Multiple Measurements in Taxonomic Problems. *Annals of Eugenics*. **7**(2), 179–188 (1936). doi:10.1111/j.1469-1809.1936.tb02137.x
7. Kabinet Ministriv Ukrainy: Deiaki pytannia vyznachennia serednostrokovykh prioritytetnykh napriamiv innovatsiinoi diialnosti zahalnodержavnogo rivnia na 2017-2021 roky (Certain issues of specifying medium-term priorities of the national-level innovative activity for 2017-2021). *Zakonodavstvo Ukrainy*. <https://zakon.rada.gov.ua/laws/show/1056-2016-%D0%BF> (2016). Accessed 21 Mar 2019
8. Kabinet Ministriv Ukrainy: Deiaki pytannia vyznachennia serednostrokovykh prioritytetnykh napriamiv innovatsiinoi diialnosti haluzevoho rivnia na 2017-2021 roky (Certain issues of specifying medium-term priorities of the sectoral-level innovative activity for 2017-2021). *Zakonodavstvo Ukrainy*. <https://zakon.rada.gov.ua/laws/show/980-2017-%D0%BF> (2017). Accessed 21 Mar 2019
9. Kiv, A.E., Semerikov, S.O., Soloviev, V.N., Striuk, A.M.: First student workshop on computer science & software engineering. In: Kiv, A.E., Semerikov, S.O., Soloviev, V.N., Striuk, A.M. (eds.) *Proceedings of the 1st Student Workshop on Computer Science & Software Engineering (CS&SE@SW 2018)*, Kryvyi Rih, Ukraine, November 30, 2018.

- CEUR Workshop Proceedings. **2292**, 1–10. <http://ceur-ws.org/Vol-2292/paper00.pdf> (2018). Accessed 31 Dec 2018
10. Markova, O., Semerikov, S., Popel, M.: CoCalc as a Learning Tool for Neural Network Simulation in the Special Course “Foundations of Mathematic Informatics”. In: Ermolayev, V., Suárez-Figueroa, M.C., Yakovyna, V., Kharchenko, V., Kobets, V., Kravtsov, H., Peschanenko, V., Prytula, Ya., Nikitchenko, M., Spivakovsky A. (eds.) Proceedings of the 14th International Conference on ICT in Education, Research and Industrial Applications. Integration, Harmonization and Knowledge Transfer (ICTERI, 2018), Kyiv, Ukraine, 14–17 May 2018, vol. II: Workshops. CEUR Workshop Proceedings. **2104**, 338–403. [http://ceur-ws.org/Vol-2104/paper\\_204.pdf](http://ceur-ws.org/Vol-2104/paper_204.pdf) (2018). Accessed 30 Nov 2018
  11. Markova, O.M., Semerikov, S.O., Striuk, A.M.: The cloud technologies of learning: origin. *Information Technologies and Learning Tools*. **46**(2), 29–44 (2015). doi:10.33407/itlt.v46i2.1234
  12. Markova, O.M.: The tools of cloud technology for learning of fundamentals of mathematical informatics for students of technical universities. In: Semerikov, S.O., Shyshkina, M.P. (eds.) Proceedings of the 5th Workshop on Cloud Technologies in Education (CTE 2017), Kryvyi Rih, Ukraine, April 28, 2017. CEUR Workshop Proceedings. **2168**, 27–33. <http://ceur-ws.org/Vol-2168/paper5.pdf> (2018). Accessed 15 Sep 2018
  13. Mitchell, T.M.: Key Ideas in Machine Learning. <http://www.cs.cmu.edu/%7Etom/mlbook/keyIdeas.pdf> (2017). Accessed 28 Jan 2019
  14. Modlo, Ye.O., Semerikov, S.O.: Xcos on Web as a promising learning tool for Bachelor’s of Electromechanics modeling of technical objects. In: Semerikov, S.O., Shyshkina, M.P. (eds.) Proceedings of the 5th Workshop on Cloud Technologies in Education (CTE 2017), Kryvyi Rih, Ukraine, April 28, 2017. CEUR Workshop Proceedings. **2168**, 34–41. <http://ceur-ws.org/Vol-2168/paper6.pdf> (2018). Accessed 15 Sep 2018
  15. Schwab, K., Davis, N.: *Shaping the Fourth Industrial Revolution*. Portfolio Penguin, London (2018)
  16. Semerikov, S.O., Teplytskyi, I.O., Yechkalo, Yu.V., Kiv, A.E.: Computer Simulation of Neural Networks Using Spreadsheets: The Dawn of the Age of Camelot. In: Kiv, A.E., Soloviev, V.N. (eds.) Proceedings of the 1st International Workshop on Augmented Reality in Education (AREdu 2018), Kryvyi Rih, Ukraine, October 2, 2018. CEUR Workshop Proceedings. **2257**, 122–147. <http://ceur-ws.org/Vol-2257/paper14.pdf>. Accessed 21 Mar 2019
  17. Semerikov, S.O., Teplytskyi, I.O.: Metodyka uvedennia osnov Machine learning u shkilnomu kursu informatyky (Methods of introducing the basics of Machine learning in the school course of informatics). In: Problems of informatization of the educational process in institutions of general secondary and higher education, Ukrainian scientific and practical conference, Kyiv, October 09, 2018, pp. 18–20. Vyd-vo NPU imeni M. P. Drahomanova, Kyiv (2018)
  18. Semerikov, S.O.: Zastosuvannia metodiv mashynnoho navchannia u navchanni modeliuвання maibutnikh uchyteliv khimii (The use of machine learning methods in teaching modeling future chemistry teachers). In: Starova, T.V. (ed.) Technologies of teaching chemistry at school and university, Ukrainian Scientific and Practical Internet Conference, Kryvyi Rih, November 2018, pp. 10–19. KDPU, Kryvyi Rih (2018)
  19. Shokaliuk, S.V., Markova, O.M., Semerikov, S.O.: SageMathCloud yak zasib khmarnykh tekhnolohii kompiuterno-orientovanoho navchannia matematychnykh ta informatychnykh dystsyplyn (SageMathCloud as the Learning Tool Cloud Technologies of the Computer-

- Based Studying Mathematics and Informatics Disciplines). In: Soloviov, V.M. (ed.) *Modeling in Education: State. Problems. Prospects*, pp. 130-142. Brama, Cherkasy (2017)
20. Stebbins, G.L.: *Edgar Anderson 1897-1969*. National Academy of Sciences, Washington (1978)
  21. Syrovatskyi, O.V., Semerikov, S.O., Modlo, Ye.O., Yechkalo, Yu.V., Zelinska, S.O.: Augmented reality software design for educational purposes. In: Kiv, A.E., Semerikov, S.O., Soloviev, V.N., Striuk, A.M. (eds.) *Proceedings of the 1st Student Workshop on Computer Science & Software Engineering (CS&SE@SW 2018)*, Kryvyi Rih, Ukraine, November 30, 2018. *CEUR Workshop Proceedings*. **2292**, 193–225. <http://ceur-ws.org/Vol-2292/paper20.pdf> (2018). Accessed 31 Dec 2018
  22. Teplytskyi, I.O., Teplytskyi, O.I., Humeniuk, A.P.: Seredovyshcha modeliuvannia: vid zaminy do intehratsii (Modeling environments: from replacement to integration). *New computer technology*. **6**, 67–68 (2008)
  23. Turavinina, O.M., Semerikov, S.O.: Zmist navchannia osnov matematychnoi informatyky studentiv tekhnichnykh universytetiv (Contents of the learning of the foundations of mathematical informatics of students of technical universities). In: *Proceedings of the International scientific and methodical conference on Development of intellectual abilities and creative abilities of students and students in the process of teaching disciplines of the natural sciences and mathematics cycle*, Sumy State Pedagogical University named after A. S. Makarenko, Sumy, 6-7 December 2012, pp. 142–145. *Vyd-vo SumDPU im. A. S. Makarenka*, Sumy (2012)
  24. Turavinina, O.M.: Matematychna informatyka u systemi fundamentalizatsii navchannia studentiv tekhnichnykh universytetiv (Mathematical informatics in the system fundamentalization learning the students of technical universities). *Zbirnyk naukovykh prats Kamianets-Podilskoho natsionalnoho universytetu. Seriiia pedahohichna*. **18**, 189-191 (2012)

# Computer Modelling of Educational Process as the Way to Modern Learning Technologies

Tatyana Zaytseva<sup>[0000-0001-6780-719X]</sup>, Lyudmila Kravtsova<sup>[0000-0002-0152-635X]</sup>  
and Anna Puliaieva<sup>[0000-0003-0595-6709]</sup>

Kherson State Maritime Academy, 20, Ushakova Str., Kherson, 73000, Ukraine  
sunny@ksu.ks.ua, limonova@ukr.net, leon85517@gmail.com

**Abstract.** Today's young people, who make up the student community, are very experienced in many issues that affect their surroundings. Therefore, each educational institution should be able to introduce new forms and methods of communication with young people, their learning, that widely involve innovative technologies, activate the creative component of education, increase the independence of students, preparing them for the future profession. This is especially true for the preparation of maritime industry specialists, whose professionalism and competence not only the preservation of the vessel and the performance of its tasks at hand depend, but also the health and, even, the life of the entire crew. Modern educational innovations offer a wide range of different software tools. But only teacher should to choose his own methodology of discipline-teaching based on what trajectory most closely matches the maximum effect of this training. Therefore, modelling of such methodology in needs of deep analyse of both the learning support systems and the student's attitude towards using of the latest information technologies in the educational process.

**Keywords:** computer modeling of educational process, interactive teaching forms, distance learning system, competency, competence-based education.

## 1 The general problem statement and its actuality

Extensive use of information and communication technologies (ICTs) at education is a requirement of time today. Comprehensive informatization requires of introduction of these changes also in organization of training students' activities, which implementation would contribute to activation of educational and cognitive activities, increasing the effectiveness of their acquisition of new knowledge, development of creative activity and skills of collectively coordinated actions. The questions of innovative technologies introduction in the educational and pedagogical process with the purpose of formation of positive motivation of the study are relevant, as it is necessary to form, on the one hand, new approaches to the teaching, and on the other hand, new approaches of knowledge, acquisition of competences on the chosen speciality.

Most importantly, for implementation of this issue is the informality choice of learning technology, which is based on ICTs, scientific justification of strategies aimed at expanding forms of self-education and individualization of the learning process.

Therefore, the Department of Information Technologies, Computer Systems and Networks (ITCSN) in own work has introduced an analytical study aimed at confirming or rejecting one pedagogical idea or another. The strategy of using innovative technologies on teaching of disciplines of ITCSN's department exactly, which by it's appoint has to be the leader in the introduction of modern technologies at the educational process, is formed on the basis of that analysis.

Experience of implementation new pedagogical forms and methods at the educational process suggests concluding that for their effective practical use it is necessary to fulfil a many important requirements, namely, the existence of strategy on which an adaptive learning trajectory must be built, an environment that is able to satisfy to users requirements, to correspond to the tasks entrusted to it, and training cadets about working in this environment on an individual schedule.

*Object of research* is computer modelling of educational process on the basis of the distance learning site of KSMA. The feature of the platform MOODLE, on which the site has developed, is the possibility of the introduction any forms of education and control knowledge, availability of constant information exchange of all participants of the educational process.

*Subject of research* is the newest conceptual approaches to using opportunities of the modern information environment, taking into account the specificities of the educational process of training specialists at Kherson State Maritime Academy.

*Objective of the work* is on development of the using modern information environment methodology based on computer modelling of the strategy of ICTs introduction at the educational process of KSMA for improving the quality of cadets' training.

These scientific and practical tasks were performed to achieve the objectives:

1. Analysis of pedagogical experience in the scope of use modern learning technologies.
2. Study of the specific aspects of distance learning system application at KSMA for training of marine specialists.
3. Conduct a scientific and pedagogical experiment to test the hypothesis of level formation of subject competencies during training sessions using of the distance learning platform.
4. Statistical analysis of the implementation results of the interactive learning model.
5. Development of the methodology of using the modern information environment, which was built on the platform MOODLE on the basis of a confirmed model for training cadets on disciplines of the ITCSN's department.
6. Development of webpage's structure of the ITCSN's department on the site of distance learning, which meets the requirements for improving the quality of the training of cadets and students of the KSMA on the disciplines of the ITCSN's department.
7. Arrangement of the webpage content and provision of academy teachers and cadets with the opportunity of convenient use of the modern information environment.
8. Introduction of interactive forms of teaching into conduction of laboratory and practical lessons on the disciplines of the ITCSN department.

9. Ensuring of the quick access to results of current or final control of knowledge on disciplines of the department in environment of the MOODLE, the analysis of results in terms of training process's quality improvement of the future maritime specialists.

In the applied aspect, this research aims at developing of methodology of using modern software product, which consumption will allow to solve an important scientific and practical task: using of modern innovative and information technology in education to improve the quality of the training specialists of maritime industry due to introduction of distance learning at KSMA.

## **2 Analysis of recent research and publications, which launched the solution to this problem**

The scientific works of some Ukrainian and foreign researchers were dedicated to the problem of organization and implementation of distance learning: H. Becker, V. Bykov [1], N. Morze, V. Oliinyk, Ye. Polat, Yu. Tryus [2] and others.

Having analyzed the publications by D. R. Garrison [3], G. Kravtsov [4], V. Kukhareenko [5], O. Rybalko, it can be noted that the use of ICT opportunities in the educational process requires organizational, research and methodological work in the implementation of modern strategies, forms and methods of distance learning.

The works of O. Pometun [6], O. Sichkaruk [7] are dedicated to the characteristics of interactive learning technologies and the description of the pedagogical experience of application of interactive teaching methods in higher school.

Problems of introduction of computer modelling in the study of informatics disciplines paid attention to foreign and Ukrainian specialists A. Bochkin [8], O. Markovich [9], I. Teplytskyi [10, 11], S. Semerikov [12], N. Valko, N. Osipova [13], Y. Samchynska [14].

The analysis of the works of the above-mentioned authors shows that the problem of the development of subject-oriented and professionally-oriented competences of future specialists of maritime industry stands insufficiently studied. Today, the analysis of the effectiveness and justification of the methodical system of application of distance learning system into the training of cadets needs further research.

Today the use of interactive multimedia learning tools is in fact a standard element in the education system of any educational institution. But the experience of application of such training tools for the training of future maritime specialists is practically absent. The analysis of publications led to the conclusion that the development of methodology of the modern distance learning platform is necessary, due to the specific aspects of the training of maritime specialists. The possibility of interactive communication with the teacher and, in general, the increase of the educational level of a seafarer remotely (as he/she spends much time outside the training institution) is very important. All these can be implemented precisely by means of distance learning programs.



### 3 Solving basic problems

KSMA as most of educational institutions not only in Ukraine, but also in the world, chose learning management system (LMS) MOODLE as a platform for realization of project “Distance learning system”. This system allows not only to introduce of learning individualization, to develop of adaptive trajectories for each user, but also to move further, maximally using this system capabilities. It’s very important for such an educational institution as maritime academy, because specific of this higher educational establishment involves long-term shipboard training for cadets who are studying full-time. So, one of the tasks of project implementation is to give cadets, who are at the practice training, the opportunities not to interrupt theoretical training and even to take part in discussing important issues in chat mode. But today just submitting of quality educational material to a student is not enough, therefore Department of Information technologies, Computer Systems and Networks of KSMA took over responsibility of introducing interactive learning technologies at the educational process.

The interactive learning is a learning that occurs on condition of the constant, active interaction of all participants in the learning process. This is coaching, mutual learning (collective, group, coaching), where both parties (the one who teaches and the one who studies) are equal subjects in the learning process, they understand what they do, know, carry out. Directly, the organization of interactive learning involves the modelling of various real-life situations, the problem-solving based on the analysis of corresponding conditions and situations, the use of role-play games. All interactive technologies are divided into four groups: frontal technologies, collective-group learning technologies, situational learning and learning in discussion. All these technologies, firstly, are vital for cadets studying in the academy, and secondly, they can be implemented on the DLS of KSMA.

As a result of application of interactive technologies, the favourable conditions are created for an effective cognitive process, thus interactive learning can speed up the process of assimilating the material, as it affects both the student’s consciousness and his/her feelings, actions, and practices.

The teachers team of the ITCSN’s department has developed own methodology for introducing a distance learning system based on the platform MOODLE as a result of thorough analysis of pedagogical experience in the use of modern training technologies and taking into account the specifics of the training specialists of maritime industry. Some corrections were made during test that is by conducting of classes according to proposed methodology which, in general by our opinion, have done the whole learning process more structured, understandable, natural, and most importantly, this learning approach was positively accepted those for whom it was developed, that is, the academy’s cadets. After a while, most academy departments supported the innovations of the ITCSN department and began to actively use the latest technologies in the educational process. So, we present a learning model with the support of innovative features of LMS MOODLE.

Exactly the ITCSN department was a founder and executor of the project “DLS of KSMA”. The first step to implementation of this project was a choice of the platform LMS MOODLE and creation of the site structure in according to specifics of training

at a marine institution. It is hierarchically and represents of input sequence: the academy – the faculty – the department — the discipline. Moreover, each teacher has a choice: either, teacher posts learning materials onto his web page, then cadet chooses the teacher and the corresponding discipline, or the teacher posts materials onto the discipline pages, then cadet chooses the discipline and teacher accordingly. For itself, the ITCNS department has chosen the second option.

Modelling of the process of computer training is the meticulously calculated relationship between the teacher's activity and independent work of the student (cadet). At the stage of introducing innovative technologies into the educational process the role of a teacher as a tutor, coordinator of the learning process is more important than ever. The author's materials of discipline will be read by the cadet directly on the web site of distance learning, using his own access to the materials as a course participant. Teacher at the lessons focuses cadets' attention on the most important points of the topic, explains how to properly use materials, which forms of control are provided by the plan.

Results of experiment were laid in the basis of modelling, which purpose was to find out the impact of the newest methods of training on the level of mastering the material by cadets, increasing their independence in its processing, interest in the results, consolidate the skills of using the acquired knowledge in the decision of professional problems. To conduct the experiment, it was necessary to select a certain number of participants, these were first-year cadets of full-time and part-time study of Navigation Faculty and Marine Engineering Faculty. The main requirement for such a totality of participants is a qualitative homogeneity. The members of the totality can be compared with each other only in relation to that sign (in our case, it is the level of the formed subject competences), which becomes the subject of the study.

The use of most statistical methods is based on the idea of using a random totality of probationers from the total number of those on which conclusions can be disseminated, in our case, these were all 100% of first-year students, which is due of the real learning process during which we conducted the experiment.

The first stage, an asserting experiment was conducted during 2016-2017 education year. The purpose of the asserting experiment was to find out the level of formation of the necessary competencies of cadets, the level of mastering the system of basic methods of mental activity and the ability of cadets to a productive independent work. The results of the asserting experiment allowed to reveal the level of knowledge, skills and abilities of cadets on such disciplines as "Information Technologies", "Information Technologies in Marine Engineering" and "Information Technologies in Navigation".

In a significant part of the cadets there was a gap between theoretical knowledge and the ability to apply its in practice, in solving new non-standard or professionally-directed tasks. The reasons for the instability of the acquired skills are the passivity of the cadets in studying and fixing new material, the lack of positive motivations for training, the impossibility of taking into account the individual characteristics and abilities of each cadet from teachers' side, the lack of necessary self-control and lack of control at all stages of mastering the complex of competencies from teachers' side.

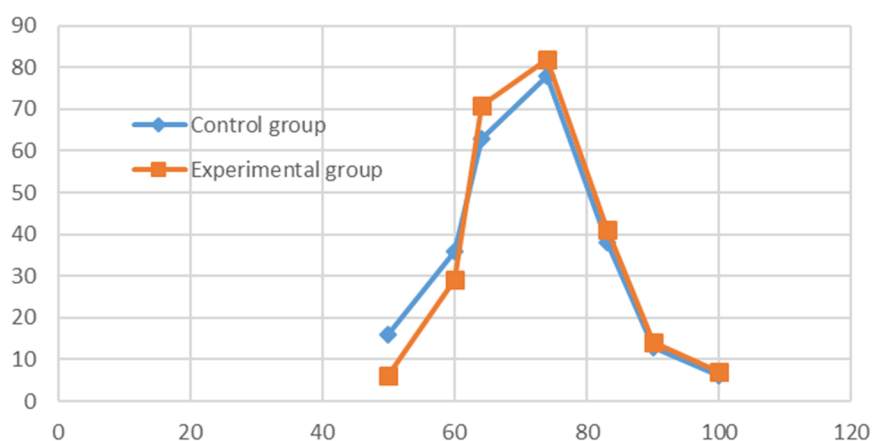
The organization of the experiment allowed to receive an accurate quantitative assessment of the research results. In particular, the actual level of knowledge, skills

and abilities on the department's disciplines was revealed and with great accuracy, a comparative analysis of the level of competency formation taking into account various categories and factors was conducted with the help of elements of variation statistics. A quantitative type of data variation was used for obtain objective data: discrete variation – the final estimates of the cadets by subject was evaluated, and the continuous – the average marks of current assessments of cadets from each single topic.

The variational series were built by the average grades of cadets and the final estimates. For constructing a discrete variational series in the analysis of the final estimates we obtained a frequency distribution table on the set of observed values of the investigated value and the variational curve (Table 1).

**Table 1.** Frequency distribution

Grade points (W)	30-59	60-63	64-73	74-82	83-89	90-98	99-100
Number of cadets in the control group (f1)	16	36	63	78	38	13	6
Number of cadets in the experimental group (f2)	6	29	71	82	41	14	7



**Fig. 1.** Variational curves

The variational and statistical indicators were calculated for versatile and full characteristics of the variation. One of them is the weighted average value or the average of variation values of a specific set:

$$M = \sum \frac{f_i \cdot W_i}{n} \quad (1)$$

The average of variation values will be closer to the values that occur more often. Therefore, first of all, you should expect to get most of the values close to this value in future observations. The average doesn't fully characterize the series, because the different variational series may have the same average value. Consequently, the essential characteristics of the distribution are also the characteristics of the frequencies

scattering, in particular the standard deviation ( $\sigma$ ) of the observed values of the investigated value from the arithmetic average, and the dispersion (D) is the measure of variation. To characterize the degree of series variation, the standard deviation of variations was determined by the formula:

$$\sigma = \sqrt{\frac{\sum_{i=1}^n (X_i - M)^2}{n - 1}} \quad (2)$$

The average error of the arithmetic average was calculated by the formula:

$$m = \pm \frac{\sigma}{\sqrt{n}} \quad (3)$$

The arithmetic average and standard deviation are the best characteristics of the group. The first is a generalized indicator of the achieved level of the group on average, and the second – the score of variation.

After calculating a number of variational and statistical indicators, the relative average error of the arithmetic average, which is an indicator of the relative accuracy of the study, was found. This value indicates to the degree of correspondence numerical values which were found in the study with the values that characterize the phenomenon being studied:

$$P = \frac{100 \cdot m}{M} \% \quad (4)$$

**Table 2.** Variational and statistical indicators

	Weighted average (M)	Average arithmetic error (m)	Mean standard deviation ( $\sigma$ )	Relative average error of the arithmetic mean (P)
Control group	3,754	0,04554	0,72	1,21%
Experimental group	3,860	0,03949	0,624	1,02%

*Conclusion:* The value of variation and statistical indicators of the studied variational population can be extended to the whole population (at  $P < 2\%$  – the accuracy is high).

The lower the absolute value of the relative accuracy of the study, the more accurate the study, the better obtained statistical indicators.

Let the hypothesis  $H_0$  asserts that the level of the formation of subject competences during conducting training sessions using the distance learning platform and interactive forms of work doesn't exceed the effectiveness of the traditional method of teaching discipline. We will assume as a hypothesis  $H_1$  the opposite assertion to the hypothesis  $H_0$ . The final works were conducted in the experimental and control groups, by results of which the criteria statistics were calculated. Here is an example of the results of one of the final work (Table 3).

The critical value of criteria statistics was found by the formula:

$$T_{cr} = \alpha \cdot \sqrt{\frac{n_1 + n_2}{n_1 \cdot n_2}} \quad (5)$$

where  $n_1=n_2=140$ ,  $\alpha=1,36$ . We get:  $T_{cr}=0,162$ .

The experimental values of statistics were calculated according to the formula:

$$T_{exp} = \frac{1}{n} \max \left( \sum f_2 - \sum f_1 \right) \quad (6)$$

**Table 3.** Statistical indicators

The number of correct answers	Abs. frequency of the experimental sample ( $f_1$ )	Abs. frequency of the control sample ( $f_2$ )	Accumulating frequency $\sum f_1$	Accumulating frequency $\sum f_2$	$\sum f_2 - \sum f_1$
5	15	9	140	140	0
4	44	25	125	131	6
3	77	96	81	106	25
2	4	10	4	10	6

Since  $\max(\sum f_2 - \sum f_1)=25$ , then  $T_{exp}=25/140=0.179$ .

Since  $T_{exp} > T_{cr}$ , then the hypothesis  $H_0$  was discarded in accordance with the decision rule for the two-sided Kolmogorov-Smirnov criterion and the hypothesis  $H_1$  was adopted.

The obtained results allowed to state the positive impact of the introduction of modern learning technology on the quality of training future maritime specialists, and to continue the formation of a strategy that would increase the degree of cadets' competencies after the completion of the course.

The main source of motivation is the professional interest of the student as a result of which the educational activity characteristics a high level of activity.

The interactive learning allows to implement an individual approach to the training of each cadet, taking into account his/her level of training, personal qualities, such as the speed of perception of information, its comprehension, the ability to use this information in solving his/her professional tasks. Today, the concepts of adaptive learning, personalization of learning, individual learning paths are widely discussed in the field of distance learning, blended learning and e-learning. Therefore, the introduction of modern technologies into the educational process allows to develop an individual learning path for each cadet. Of course, the essential condition of the adaptive learning is a desire of the trainee to acquire new knowledge, make every effort to achieve his/her goal – acquiring of essential knowledge necessary for his/her professional activity.

Nowadays it is not enough for the teacher to be competent in the field of the discipline he/she teaches, present theoretical knowledge in the class. It is necessary to meet the requirements of the modern educational process. The teacher often acts only as the organizer of the learning process, the leader of the group, creating conditions for the initiative of the cadets. The interactive learning is based on the experience of the youth, on their direct interaction in the field of professional experience. All participants of the learning process interact with each other, share information, solve problems

together, simulate situations, evaluate the actions of the others and their own behavior, immerse into the real atmosphere of business cooperation in dealing with problems.

Using of network technologies promotes not only the acquisition of knowledge, skills, forms of professional behavior by cadets (students), but also the formation of a certain structure of personal qualities. The study of the conditions of formation of the future specialists' professional competence by means of network technologies allowed to determine that the introduction of a academic and learning kit which contains distance courses developed by means of MOODLE using a modular approach, the presentation of knowledge as a dynamic, multimodal structure in the formation of which the students take part, enhances the student's experience of self-replenishment and renewal of professional knowledge, personal involvement in this process and responsibility for it. Modular training is based on active, flexible approach to determining the sequence of learning material presentation, and the module itself is defined as an integral system that combines the training content and the technology of mastering it. An important criterion for constructing a module is the structuring of the student's activities in the logical sequence of acquisition of knowledge: perception, understanding, comprehension, memorization, application, generalization, systematization of acquired knowledge.

Accordingly, the implementation of distance learning forms and methods contributes to the individualization of the professional development process, stimulates higher education student to work independently, forms their informational culture, sets for mastery of innovative means of obtaining and applying information, in particular, the possibilities of distance learning contribute to formation of professional competence of future specialists of the maritime industry.

The National System of Higher Education Standards clearly specifies the requirements for qualifications and provides a list of socially and professionally relevant knowledge, skills and competences which demand from graduate of institution of higher education not only the national labour market but and the European Community. The National Qualification System, in particular its components - National and branch qualification frameworks shall be the basis for the implementation of a competence-based approach in higher education. The compliance of the quality of graduates' training with the requirements of the industry standard of higher education shall be determined by socio-personal, general scientific, instrumental and professional competencies. The implementation of competently communicative approach at the educational process requires not so new subject content [15] as different pedagogical technologies.

The results of research were presented at the All-Ukrainian and International conferences, published in the popular scientific journals and posted on the distance site of KSMA by electronic link <http://www.mdl.kma.ks.ua/>.

The efficiency of using interactive teaching methods by discipline "Information technology" can be shown on the example navigation tasks, which is encountered in practice of navigator. That is, the conducting navigation calculations during plan of ship's transition using opportunities MS Excel. The consolidation of practical skills of getting a numerical result by analytic description dependents of parametrics of some technical process is goal of work. Given the coordinates of the points of ship's transition

A, B, C, D, E, F (longitude  $\lambda_i$  and latitude  $\varphi_i$ ). Needs to determine course for each ship's transition and its distance run by each transition. In this case, of course, the coordinates are given in the form in which it is accepted in the performance of navigation calculations (see Fig. 2).

Moving the ship "Eagle 3"						
Transition point	Coordinates					
	latitude			longitude		
	degrees	minutes		degrees	minutes	
A	57	25,00	N	20	26,00	E
B	57	55,60	N	20	30,00	E
C	58	23,60	N	21	34,90	E
D	58	5,70	N	22	43,70	E
E	57	14,60	N	22	33,00	E
F	57	5,00	N	22	0,00	E

Fig. 2. Initial data are entered in the table.

The mathematical model of the task is a, in the fact, two formulas – determination of absolute value of the course and distance run:

$$\operatorname{tg} C_i = \frac{D\text{Long}_i \cdot \cos(\varphi_{p_i})}{D\text{Lat}_i} \quad (7)$$

$$S_i = \sqrt{(\varphi_{i+1} - \varphi_i)^2 + ((\lambda_{i+1} - \lambda_i) \cdot \cos(\varphi_{cp}))^2} \quad (8)$$

The round system calculation of direction is used in navigation for determination of direction of ship's movement (course) and determination of direction from the ship to the shore marks, neighboring ships and other (bearing).

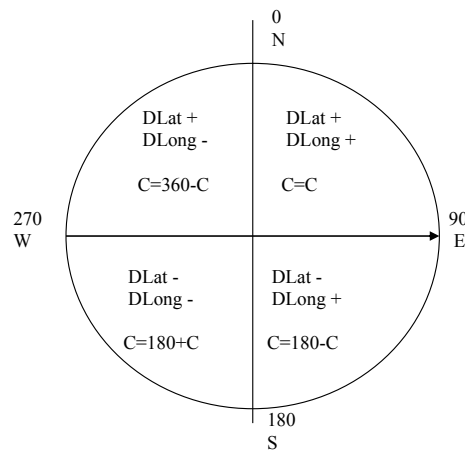


Fig. 3. The round system calculation

It would seem that, there are initial data, calculation formulas – it is possible to proceed of execution. But cadet won't cope with this task without teacher's explanations. At the first, initial data must be converted into a form which will be suitable for conducting calculations. For this we take into account that 1 minute is a 1/60 part of degree. Therefore, latitudes and longitudes are recounting and difference of latitude (DLat), difference of longitude (DLon) and middle latitude ( $\varphi_m$ ).

Now we need to use the formula (1) for determination of the course taking into account that course  $C_i$  is under the sign of the tangent, so, for calculating of the course we have to use inverse function to tangent – arctangent. Next, arctangent function returns result in radians that is in linear units (arc length). Therefore we must to convert result in degree measure of angle measurement. As by the task condition needs find of the course, we calculate the absolute value (ABS) of the resulting value (see Fig. 4).

Moving the ship "Eagle 3"										
transition point	Coordinates									
	latitude					longitude				
	degrees	minutes		degrees	minutes		latitude (degrees)	longitude (degrees)	difference of longitude	middle latitude
A	57	25,00	N	20	26,00	E	57,42	20,43	0,07	57,67
B	57	55,60	N	20	30,00	E	57,93	20,50	1,08	58,16
C	58	23,60	N	21	34,90	E	58,39	21,58	1,15	58,24
D	58	5,70	N	22	43,70	E	58,10	22,73	-0,18	57,67
E	57	14,60	N	22	33,00	E	57,24	22,55	-0,55	57,16
F	57	5,00	N	22	0,00	E	57,08	22,00	-22,00	28,54

Fig. 4. Performing calculations

On the next stage we need to determine ship course on the each transition. For this will be use round system calculation of direction (Fig. 3). Here is obviously the use of the logical apparatus (the logical function "IF"). And the final, needs calculate distance between points. The formula of distance's calculating (8) is very simple, with the exception of a small nuance: result of calculation of the right part obtains in degrees and the left part (distance traveled) is measured in nautical miles. As ship transition on 60 nautical miles match to changing the position of the vessel by one degree, obtained result by formula (8) needs to multiply by 60. The calculations are done correctly. Now we can plot a course (see Fig. 5).

Moving the ship "Eagle 3"										
transition point	Coordinates									
	latitude					longitude				
	degrees	minutes		degrees	minutes		modules	courses	distance	
A	57	25,00	N	20	26,00	E	4,00	4	30,67	
B	57	55,60	N	20	30,00	E	50,72	51	44,23	
C	58	23,60	N	21	34,90	E	63,69	116	40,39	
D	58	5,70	N	22	43,70	E	6,39	186	51,42	
E	57	14,60	N	22	33,00	E	61,79	242	20,31	
F	57	5,00	N	22	0,00	E	18,70			

Fig. 5. Calculating ship course and distance between points of ship transition



If a cadet was absent on the classroom lesson for good reason or didn't fully master the topic, he can easily independently understand the task solution using interactive materials created by teachers and uploaded on the distance learning site. The monitoring of cadets' visits of the pages of the site by disciplines of the department shows that most cadets are actively using innovations in the learning process and results of performing of the individual tasks which recorded in an electronic journal, confirm the hypothesis of raising the level of assimilation of the material by the cadet when teacher gave full information provision of the discipline and methodically substantiated the combination of classroom, individual and independent work of the cadet.

The systematic implementation of the test control at the learning process is an essential part of the reformation of views on results of higher education which should be variety on training forms, to have the practical-applied character and differ in the scope of interdisciplinary tasks.

We'd like to mention that a complex final testing is a complete set of tests that involves testing of competencies of several different disciplines at the same time. This test reveals the quality of the integrated training of a future seafarer, his ability to interpret various professional tasks. For example, the final test in navigation course included the questions of different disciplines: navigation, theory of ship construction, celestial navigation, electrical and radio navigational equipment and others. Some questions were in the English language.

The final assessment consisted of two equal components: assessment of current student's progress by the teacher (from 0 to 50 points); independent assessment (the result of testing is automatically calculated by the system, the maximum score is 50).

The objective of the final assessment in the form of a final testing is a detection of the cadets' level of knowledge, skills, competences and level of readiness to compete in the labour market of the maritime industry. This method of knowledge check firstly provides the students with an opportunity to evaluate their own level of knowledge, and secondly, it familiarized the cadets with the testing procedure that is conducted by different crewing companies. This is confirmed by the fact that the training and assessment of cadets' knowledge is carried out in an integrated manner, taking into account the requirements to the competence-based training of future maritime specialists. The systematic application of such tests creates favorable conditions for the training of future maritime specialists in terms of employment testing by national and foreign crewing companies.

A survey was conducted among first-year students based on the results of the training in the current academic year. The questionnaire included both questions concerning to the directly use of the distance learning system and questions on the estimation of the level of material assimilation taking into account the use of interactive technologies. More than a hundred cadets participated in the survey. They have been asked to give an objective personal evaluation of the structure and methodology of training in the IT department.

The questionnaire contained 25 questions. The table presents some diverse examples of questions (Table 4).

**Table 4.** Questionnaire for cadets

1	Evaluate the degree of mastering the theme by materials of the distance learning site	<ul style="list-style-type: none"> <li>- 100%,</li> <li>- 75%,</li> <li>- 50%,</li> <li>- 25%,</li> <li>- less than 25% of the training material</li> </ul>
2	How do you perform an individual task?	<ul style="list-style-type: none"> <li>- independently,</li> <li>- partly on your own,</li> <li>- with the help of other cadets,</li> <li>- only under the direction of a teacher</li> </ul>
3	Evaluate your degree of mastering the study material	<ul style="list-style-type: none"> <li>- high,</li> <li>- sufficient,</li> <li>- average,</li> <li>- low</li> </ul>
4	How do you organize your own work?	<ul style="list-style-type: none"> <li>- I always do it myself,</li> <li>- do it with the help of other cadets,</li> <li>- perform it using of additional educational materials,</li> <li>- do it sometimes,</li> <li>- I don't perform it</li> </ul>
5	How long does it take for you to complete the tasks after reading the interactive materials on the topic?	<ul style="list-style-type: none"> <li>- more than 2 hours,</li> <li>- from 1 hour to 2 hours,</li> <li>- from 30 minutes to 1 hour,</li> <li>- less than 30 minutes.</li> </ul>
6	Choose the appropriate option to complete the sentence (Self-assessment of the acquired knowledge). After completing the module (course) I ...	<ul style="list-style-type: none"> <li>- have a clear idea of the cognitive outcomes of my learning activities;</li> <li>- clearly imagine what competencies (skills and abilities) have mastered;</li> <li>- imagine where I will be able to apply the existing competencies in the future;</li> <li>- the learning process became conscious, and therefore more effective;</li> <li>- performed automatically without imagining any further application.</li> </ul>

The following conclusions were made based on the results of the survey:

1. To questions about the estimation of the usefulness of active and interactive methods of teaching (the degree of mastering the topic during the classroom session, using the materials of the distance learning site, joint discussion of the teaching material, the use of multimedia computer equipment, etc.) were answered: no use – 0%; insignificant degree – 10%; sufficient degree – 71%; high degree – 19% of cadets.
2. For questions about the approximate assessment (in percentage) of professional competencies, skills and abilities obtained in the study of disciplines by modern learning methods compared to the traditional methods of learning, 78% supported the use of interactive learning systems, 16% used the opportunities of the distance learning site from time to time, 6% preferred to use printed methodological materials.
3. To questions about the interaction (asking for help to other cadets or helping them to study the material, teamwork on assignments) 10% answered “almost never”, 54% answered “sometimes”, 26% answered “often”, and 4% answered “constantly”, the

others couldn't decide on the answer.

4. The reduction of the learning time using multimedia equipment on the classroom session (according to cadets' estimates) was 82% on average.
5. All cadets were positively evaluated the effectiveness of the use of training and interactive materials posted on the distance learning site when they self-studying the topic.

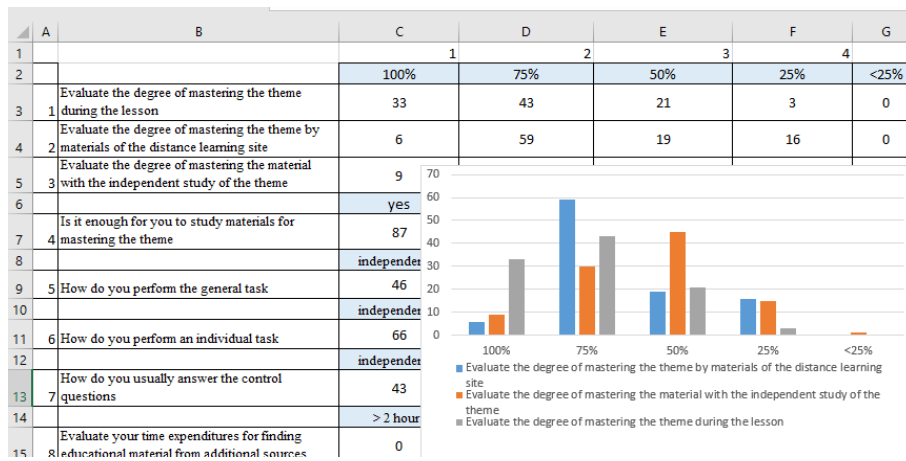


Fig. 6. Survey results

#### 4 Conclusions and directions for further research

For today, the modern learning technologies have become available for use in the educational process of any educational institution. But the analysis of LMS MOODLE possibilities has shown that a science-based approach to computer modelling of educational process is most effective mean of creating own methodology, that would combine traditional and innovative forms of knowledge acquisition by cadets taking into account the competence approach and specifics of the training specialists of marine industry, whom are competitive at the world labour market.

The results of the scientific and pedagogical experiment of testing the hypothesis of level formation of subject competencies during classroom and extracurricular activities using the distance learning platform proved that the structure meets the requirements both of the, who create necessary conditions for the cadets' qualitative training, and for cadets who become more motivated at the obtaining knowledge process and their application in solving professional problems.

As a consequence of the obtained results, it was determined that when performing the procedure for introducing a distance learning system at the educational process of KSMA special attention should be focus in equal on the creation of the educational and methodological materials for cadets self-study, a high quality testing system for checking their knowledge and interactive forms of distance learning.

The interactive learning methods on the basis of DLS MOODLE of KSMA have a

positive impact on the quality of cadets' training, the development of their professional competencies necessary for a successful competition on the world labour market.

Today, the first results of the implementation of the competency-based approach into the learning process already exist. The connection of the results and competencies is a complex question that requires much attention. The commitment to the results of education is an urgent problem for modern Ukrainian higher school and requires the integration of academic and vocational education, the recognition of qualifications obtained in the process of higher education and the development of lifelong education.

## References

1. Bykov, V.Yu., Lapinsky, V.V.: Methodological and methodological foundations for the creation and use of electronic educational tools. *Computer in School and Family*. 2, 3-6 (2012)
2. Trius, Yu.V., Gerasimenko, I.V., Franchuk V.M.: Electronic HEI system based on MOODLE. Cherkassy (2016)
3. Garrison, D.R, Anderson, T., Archer, W.: Critical thinking, cognitive presence, and computer conferencing in distance education. *The American Journal of Distance Education*. **15**(1), 7–23 (2009). doi:10.1080/08923640109527071
4. Kravtsov, H., Kobets, V.: Implementation of Stakeholders' Requirements and Innovations for ICT Curriculum through Relevant Competences. *CEUR Workshop Proceedings*. **1844**, 414–427. <http://ceur-ws.org/Vol-1844/10000414.pdf> (2017). Accessed 21 Mar 2019
5. Kukhareno, V.M., Rybalko, O.V., Syrotenko, N.G. (ed.): *Distance Learning: Terms of Use*. Distance course. NTU KhPI Torsing, Kharkiv (2008)
6. Pometun, O.I.: *Encyclopedia of interactive learning*. A.S.K., Kiev (2007)
7. Sichkaruk, O.I.: *Interactive methods of teaching at a high school: tutorial manual*. Takson, Kiev (2006)
8. Bochkin, A.I.: *Methods of teaching computer science*. Higher School, Minsk (1998)
9. Markovich, O.S.: Computer modeling in educational research: the development of new teaching methods using information technology. *Modern problems of science and education*. 5. <https://science-education.ru/ru/article/view?id=21724> (2015). Accessed 21 Mar 2019
10. Teplytskyi, I.O.: *Elements of computer modeling: textbook*. KDPU, Krivoy Rog (2010)
11. Teplytskyi, O.I., Teplytskyi, I.O.: Object-oriented simulation models: the construction of "Life". *Scientific journal of Drahomanov NPU, Series 2: Computer-Oriented Learning Systems* 12, 173–182 (2012)
12. Semerikov, S.O., Mintii, I.S., Slovak, K.I., Teplytskyi, I.O., Teplytskyi, O.I.: Mobile software for teaching computer science in high school. *Scientific journal of Drahomanov NPU. Series 2: Computer-Oriented Learning Systems*. 8, 20–29 (2010)
13. Kushnir, N., Valko, N., Osipova, N., Bazanova, L.: Experience of Foundation STEM-School. *CEUR Workshop Proceedings*. **2104**, 431–446. [http://www.ceur-ws.org/Vol-2104/paper\\_241.pdf](http://www.ceur-ws.org/Vol-2104/paper_241.pdf) (2019). Accessed 21 Mar 2019
14. Samchynska, Y., Vinnyk, M.: Decision Making in Information Technologies Governance of Companies. *CEUR Workshop Proceedings*. **1844**, 96–110. <http://ceur-ws.org/Vol-1844/10000096.pdf> (2017). Accessed 21 Mar 2019
15. Zaytseva, T.: The Introduction of the Competence-based Approach in Educational Process of Training of Skippers. *CEUR Workshop Proceedings*. **1614**, 687–699. [http://ceur-ws.org/Vol-1614/paper\\_25.pdf](http://ceur-ws.org/Vol-1614/paper_25.pdf) (2016). Accessed 21 Mar 2019

# The Simultaneous Use of Excel and GeoGebra to Training the Basics of Mathematical Modeling

Leonid Flehantov<sup>[0000-0002-4689-1457]</sup> and Yuliia Ovsiienko<sup>[0000-0002-4873-9061]</sup>

Poltava State Agrarian Academy, G. Skovorody str., 1/3, Poltava, 36003, Ukraine

leonid.flegantov@pdaa.edu.ua, iuliia.ovsiienko@pdaa.edu.ua

**Abstract.** The main objective of this study is testing the hypothesis that the visualization of simulation results creates the conditions for improving students' knowledge, taking into account the specifics of their professional training. In this article we are exploring how the simultaneous use of Excel and GeoGebra can improve the learning outcomes of engineering students in agricultural universities when learning the basics of mathematical modeling (using as example the mathematical model of mechanical movement of two bodies with their elastic collision). We worked with our students as follows. First, we build and interpret the mathematical model. Then we obtain two alternative computer models: we use Excel spreadsheets for numerical modeling as well as GeoGebra software for analytical-geometrical modeling. By this models we visualize and explore the processes closely related to topics that plays an important role in the training of agricultural production engineers, in particular, with study the movement and interaction of particles during the loading / unloading of seeds, the description of industrial processes of seed scarification, with study of the movement of particles of yeast suspension in a plate separators, modeling the processes of shot-blast cleaning of metal surfaces etc. We have tested this approach in teaching the 163 students enrolled in the specialties "Agroengineering" and "Industry Engineering" in Poltava State Agrarian Academy. According to data we collected our students demonstrated a better understanding of the conceptual issues of mathematical modeling and acquired significant abilities in using this method to solve real problems.

**Keywords:** Basics of mathematical modeling, computer simulation of mechanical movement, software used in learning of modeling, computer simulation and visualization, simultaneous use Excel and GeoGebra.

## 1 Introduction

Learning for basics of mathematical modeling (BMM) is an important component in the training of modern agrarian production engineers. Its practical value is due to the fact that learning based on mathematical modeling can be an effective strategy in modern realities [13].

Currently, the entrants to the engineering specialties of agricultural institutions of higher education in Ukraine (IHEs) have a relatively low level of training in mathematics, physics and other related disciplines, as compared with entrants of other technical specialties. In most cases, in the further education, they also demonstrate little progress in the study of mathematical disciplines. Additionally, it should be noted that among students of engineering specialties in agrarian IHEs, the male population is traditionally dominated. However, the consideration of gender characteristics in the training of BMM is not critical for students of the student age, as evidenced in particular by the results of research on gender stereotypes in mathematics teaching [16].

In the learning for mathematical modeling, computer software is considered as an integral component of a three-point didactic model (student – teacher – information and communication pedagogical environment (ICPE)) [18]. By choosing Excel spreadsheets and GeoGebra dynamic geometry system for training of BMM, we were guided by the certain criteria for selecting educational software applications proposed in [10, p. 32-42].

The use of Excel spreadsheets in the study of the basics of mathematical modeling is devoted to a fairly large number of scientific publications covering a variety of aspects of this scientific discipline. Their review can be found, in particular, in works [15], [17], [19], [20], [21], [22], [23] by Serhiy O. Semerikov and Illia O. Teplytskyi, where the most significant, fundamental achievements in this direction are presented.

At the same time, to the system of dynamic mathematics GeoGebra are mainly devoted the articles that describe the capabilities of this program and examples of its use in teaching.

In particular, some publications by Olena Hrybiuk [10] devoted to modeling in the GeoGebra environment during the training of mathematical and chemical-biological cycles, mathematical disciplines and mathematical fundamentals of informatics.

Marta Caligaris, María Schivo and Maria Romiti as a result of their research came to the conclusion that the incorporation of the GeoGebra Applets, and the teaching situations arising therefrom, is a much more effective teaching methodology than traditional one [4].

Nazihatulhasanah Arbain, Nurbiha A. Shukor, the authors of the study devoted to investigates the effectiveness of using GeoGebra software on Mathematics learning among students in Malaysia, are notes that results show that students have positive perception towards learning and have better learning achievement using GeoGebra [1].

In the article by Esperanza G. Valdés y Medina, Leilani Medina Valdés is shown an example of use the GeoGebra to change educational methodology, which confirms the conclusion that the software is introduced as a friendly model that can be used to exemplify the mathematical concepts ranging from the basic ones to complex applications like angular velocity [12].

Also, the big number of practical examples of using GeoGebra software for teaching mathematics and science made by other authors are presented on the GeoGebra web resource [8].

As we know, MS Excel has built-in tools for visualizing changes in values, and GeoGebra has a built-in SpreadSheet component that allows you to partially accomplish the tasks set in this study. However, the use of these opportunities is based

on the results of previous teaching of information technology, which are not provided for by the training plans of training in agricultural universities.

Thus, the analysis of modern publications was shown the practical absence of well-known scientific works devoted to the problem of the simultaneous use of Excel and GeoGebra for teaching the basics of mathematical modeling and studying their influence on the learning outcomes of the basics of mathematical modeling.

The reason for this research was the negative dynamics the final indicators of learning outcomes in the discipline BMM of the students of engineering and technical specialties of the Poltava State Agrarian Academy, Poltava, Ukraine (PDAA): the average score was in 2014 – 75.8; 2015 – 75.6; 2016 – 72.6; 2017 – 70.1.

Among the factors that have an impact on the learning outcomes, we have chosen to study the individual style of coding educational information. The published scientific data on this subject indicates that for the students of applied training areas the dominant is the visual style of coding educational information: visual learning style preferred by 61% of the students; whereas, auditory (33%) and kinesthetic (6%) [2].

On this basis we have formulated the hypothesis of the investigation that the BMM learning outcomes can be improved by the use of appropriate computer (software) visualization tools in practical and laboratory learning performances. The main objective of this study is testing the hypothesis that the visualization of simulation results creates the conditions for improving students' knowledge, taking into account the specifics of their professional training.

## **2 Experiment description**

### **2.1 General design**

This article based on the results of the experiment that we performed in September-November 2018 in PDAA. The experiment was attended by 163 students of the Faculty of Engineering and Technology, who studied the discipline of BMM in a single program. Main hypothesis of the experiment: GeoGebra software, as a computer visualization tool, will increase the level of learning outcomes of students with BMM.

The participants of the experiment were divided into three groups, each of which was offered the same learning task, which has a direct connection with the topics important in the training of engineers of agrarian production, in particular: studying the movement and interaction of particles during loading and unloading of seeds from the vehicle, description of industrial processes of seed scarification, research of motion of particles of yeast suspension in a container separator, simulation of processes of blast-blast cleaning of metal surfaces, etc.

The provided sample size makes it possible with ANOVA method to establish significant differences between group averages at the level of 1 point: at a significance level of 0.05, number of groups 3 and a power of 80%, the required sample size for groups is at least 50 units.

The first group (E) used Excel spreadsheets during the training of (traditional course). The second group (G) – used the GeoGebra dynamic geometry program (updated base course). Third group (EG) used simultaneously Excel and GeoGebra

(experimental course). The training time in all three groups was the same. Learning outcomes of the students of groups E, G and EG were evaluated based on the results of a set of typical tasks for individual independent work.

The learning task was: simulate the movement of two spherical bodies, which were thrown at an angle to the horizon towards each other, without taking into account air resistance, gravitational, electrostatic interaction of bodies, etc.; investigate the conditions of bodies' collision; body collision is considered absolutely elastic.

Some variants of the methodology for solving similar problem using Excel were considered in papers [23], [9] and MathCAD [6]. A similar technique was also used for implementation a differentiated approach while training future agroengineers [7].

Algorithm for solving this learning problem has the following steps:

1. Build a mathematical model and find its solution.
2. Create a computer implementation of a mathematical model.
3. Using a mathematical model:
  - (a) Calculate the coordinates and the speeds of the bodies at given moments of time (before the collision of bodies).
  - (b) Build trajectories of body movement before their collision.
  - (c) Determine the initial conditions of motion, in which there is a collision of bodies.
  - (d) Determine: the moment of bodies' contact, coordinates of centers and speeds of bodies at the moment of their collision.
  - (e) Determine the initial velocity of bodies after moment of their collision.
  - (f) Determine trajectories of body movement after their collision.

The learning outcomes of students were assessed on a 100-point scale (Table 1) on the basis of the performance results of an individual independent learning tasks.

**Table 1.** Methodology for assessing the performance results of an individual independent learning tasks by the students

<b>Final score</b>	<b>Points</b>	<b>The achieving level</b>	<b>The correctness task implementation</b>	<b>Self-support the performing of the learning task</b>
A	90-100	The task is full complete	without remarks and errors	by yourself
B	82-89	The task is full complete	with minor comments and / or inaccuracies that did not affect the result	by yourself
C	74-81	The task is full complete	with remarks and / or inaccuracies corrected by the student	by yourself, with little help from the teacher
D	64-73	The task is not full complete	with remarks and / or inaccuracies that affected the result and were completely corrected by the student	with help from the teacher
E	60-63	The task is not full complete	with significant comments and / or inaccuracies affecting the result and	with help from the teacher



Final score	Points	The achieving level	The correctness task implementation	Self-support the performing of the learning task
			were partially corrected by the student	
FX	35-59	The task is uncompleted	There were errors that affected the result and were only partially corrected by the student	with help from the teacher
F	0-34	The task is uncompleted	There were errors that affected the result and were not corrected by the student	with help from the teacher

## 2.2 Mathematical model building

For better understanding what follows, the authors found it necessary to provide here some basic information related to the construction of a mathematical model of motion and collision of two bodies thrown at an angle to the horizon.

Mathematical description the mechanical motion of a body was thrown at an angle to the horizon is based on the mechanical sense of the derivative and the laws of Newton's dynamics. As a result, we have a Cauchy problem for a system of four ordinary first order differential equations [5, p. 253]:

$$\begin{aligned} \frac{dx}{dt} = v_x, \quad \frac{dy}{dt} = v_y, \quad \frac{dv_x}{dt} = 0, \quad \frac{dv_y}{dt} = -g, \\ x(0) = x_0, \quad y(0) = y_0, \quad v(0) = v_0, \quad \alpha(0) = \alpha_0, \end{aligned} \quad (1)$$

where  $x = x(t)$ ,  $y = y(t)$  – coordinates of body centre,  $(v_x(t), v_y(t)) = v(t) = v$  – instant body velocity,  $\alpha = \alpha(t)$  – angle of inclination the body trajectory to the horizon. Then,

$$v_x(t) = v \cos \alpha = v_x(v, \alpha), \quad v_y(t) = v \sin \alpha = v_y(v, \alpha), \quad v = \sqrt{v_x^2 + v_y^2}, \quad \alpha = \arctg \frac{v_y}{v_x}.$$

System (1) has a simple analytical solution:

$$x(t) = x_0 + v_{0x}t, \quad y(t) = y_0 + v_{0y}t - \frac{gt^2}{2}, \quad v_x = v_{0x}, \quad v_y = v_{0y} - gt. \quad (2)$$

From where, excluding time  $t$ , we get the equation of body motion trajectory:

$$y(x) = y_0 + \frac{v_{0y}}{v_{0x}}(x - x_0) - \frac{g}{2v_{0x}^2}(x - x_0)^2 \quad (3)$$

For visualize the trajectory of the movement of body centre, we build a graph of function (3) on a segment  $t \in [t_0, t_M]$ , where  $t_M = t_k - t_0$  is the time of simulation (the time of virtual observation of the movement of each body in each phase of flight), which begins at the moment  $t_0$  and ends at the moment of the body's fall to the ground without collision  $t_k$ . From (3) for  $y_k = r$  we get:

$$t_z(y_0, v_{0y}, r) = \frac{v_{0y} \pm \sqrt{v_{0y}^2 - 2g(r - y_0)}}{g} \quad (4)$$

The collision of bodies occurs at the point  $D\left(\frac{x_1 + \lambda x_2}{1 + \lambda}, \frac{y_1 + \lambda y_2}{1 + \lambda}\right)$  which divides the segment  $O_1O_2$  with ratio  $\lambda = \frac{r_1}{r_2}$ ,  $r_1$  and  $r_2$  – effective radii of bodies 1 and 2 (Fig. 7).

The moment of collision time  $t_D$  is:

$$t_D(x_{01}, y_{01}, x_{02}, y_{02}, v_{01}, v_{02}, \alpha_{01}, \alpha_{02}, r_1, r_2) = \frac{-b + \sqrt{b^2 - 4ac}}{2a}, \quad (5)$$

where  $a = (v_{0x2} - v_{0x1})^2 + (v_{0y2} - v_{0y1})^2$ ,

$b = 2((y_{02} - y_{01})(v_{0y2} - v_{0y1}) + (x_{02} - x_{01})(v_{0x2} - v_{0x1}))$ ,

$c = (x_{02} - x_{01})^2 + (y_{02} - y_{01})^2 - (r_1 + r_2)^2$ .

Further movement of bodies 1 and 2 after their collision is described by the equations (2) with the new initial coordinates  $x_{0i} = x_{iD}$ ,  $y_{0i} = y_{iD}$  and velocities  $u_{01} = (u_{01x}, u_{01y})$ ,  $u_{02} = (u_{02x}, u_{02y})$ , which are determined from the laws of conservation of energy and momentum:

$$\begin{aligned} u_{01x} &= \frac{(m_1 - m_2)v_{1xD} + 2m_2v_{2xD}}{m_1 + m_2}, & u_{01y} &= \frac{(m_1 - m_2)v_{1yD} + 2m_2v_{2yD}}{m_1 + m_2}; \\ u_{02x} &= \frac{(m_2 - m_1)v_{2xD} + 2m_1v_{1xD}}{m_1 + m_2}, & u_{02y} &= \frac{(m_2 - m_1)v_{2yD} + 2m_1v_{1yD}}{m_1 + m_2}. \end{aligned} \quad (6)$$

The common formulas obtained here are used further to perform the next calculations. However, their implementation in Excel spreadsheets and in the GeoGebra software has its own nuances, which are reflected in the relevant sections of the article.

### 2.3 Performing the learning task with Excel (Group E)

In the Excel environment, this mathematical model is implemented according to the algorithm presented in [7].

The figure (Fig. 1) shows the input data block: the input parameters of the model in Excel are manually changed.

Final calculations are performed using standard Excel tools. The results of calculations are presented in the table (Fig. 2).

To visualize the trajectories of the movement of body centre, diagrams are constructed of the points  $(x_i, y_i)$  – the graph of function (3) on the segment  $t \in [t_0, t_M]$ .

The corresponding calculation formulas have the form:

$$n = 100, \Delta t = \frac{t_M}{n}, t_i = t_0 + i \cdot \Delta t, x_i = x_0 + v_{0x} t_i, y_i = y_0 + v_{0y} t_i - \frac{g t_i^2}{2}, i = \overline{0, n}. \quad (7)$$

	A	B	C	D	E	F	G	H	I	J	K	L
1	Simulation of the collision of two bodies								Time of collision of bodies			
2									0.4653 s			
3	General parameters of the model											
4	g=	9.81 m/s <sup>2</sup>		n=	100		t0=	0 s				
5	tM=	0.4653 s		deltaT=	0.00465 s							
6												
7	Body 1. Initial data						Body 2. Initial data					
8	d1=	1 m		d2=	0.7 m							
9	m1=	2 kg		m2=	1 kg							
10	x01=	0 m		v01x=	14.4168 m/s		x02=	10 m		v02x=	-5.44789 m/s	
11	y01=	2 m		v01y=	9.00863 m/s		y02=	1 m		v02y=	10.6921 m/s	
12	v01=	17 m/s		v02=	12 m/s							
13	alpha01=	32 degrees		0.55851 radians	alpha02=	117 degrees		2.04204 radians				

Fig. 1. The input data block of the model in Excel

	A	B	C	D	E	F	G	H	I	J	K	L
16	i	ti	x1i	y1i	x1i-	y1i-	x1i+	y1i+	v1xi	v1yi	v1i	alpha1i, rad
17	0	0	0	2	0.26496	1.575976	-0.26496	2.424024	14.41682	9.006627	17	0.558505361
18	1	0.004653	0.067081	2.041811	0.331073	1.617184	-0.19691	2.466438	14.41682	8.962962	16.97566	0.556225065
19	2	0.009306	0.134163	2.08341	0.397183	1.65818	-0.12686	2.506639	14.41682	8.917336	16.9518	0.553938285
20	3	0.013959	0.201244	2.124796	0.463289	1.698964	-0.0608	2.550627	14.41682	8.87169	16.92783	0.551645017
21	4	0.018612	0.268326	2.165969	0.52939	1.739536	0.007261	2.592403	14.41682	8.826044	16.90395	0.549345259
22	5	0.023265	0.335407	2.206931	0.595488	1.779897	0.075327	2.633965	14.41682	8.780398	16.88017	0.547039007
23	6	0.027918	0.402489	2.24768	0.661581	1.820045	0.143397	2.675314	14.41682	8.734752	16.85647	0.544726258
24	7	0.032571	0.46957	2.288216	0.72767	1.859982	0.211471	2.716451	14.41682	8.689106	16.83286	0.542407009
25	8	0.037224	0.536652	2.328541	0.793754	1.899707	0.279549	2.757374	14.41682	8.64346	16.80934	0.540081258
26	9	0.041877	0.603733	2.368652	0.859835	1.939221	0.347631	2.798084	14.41682	8.597814	16.78592	0.537749003
27	10	0.04653	0.670815	2.408552	0.925911	1.978522	0.415718	2.838582	14.41682	8.552168	16.76258	0.535410242
28	11	0.051183	0.737896	2.448239	0.991984	2.017612	0.483808	2.878866	14.41682	8.506522	16.73934	0.533064974
29	12	0.055836	0.804977	2.487714	1.058052	2.05649	0.551903	2.918937	14.41682	8.460876	16.71619	0.530713197
30	13	0.060489	0.872059	2.526976	1.124116	2.095157	0.620002	2.968795	14.41682	8.41523	16.69313	0.52835491
31	14	0.065142	0.93914	2.566026	1.190175	2.133612	0.688106	2.998439	14.41682	8.369584	16.67017	0.525990112
32	15	0.069795	1.006222	2.604863	1.25623	2.171856	0.756213	3.037871	14.41682	8.323939	16.6473	0.523618804

Fig. 2. The final calculations results in Excel (fragment of table)

The movement of the extreme points of the bodies most distant from the trajectory of the centre of the body (these points are located at the ends of the effective diameter of the body perpendicular to the direction of motion), is described by the formulas:

$$x_{i-} = x_i + r \cdot \sin \alpha_i, \quad y_{i-} = y_i - r \cdot \cos \alpha_i \quad \text{— bottom point,} \quad (8)$$

$$x_{i+} = x_i - r \cdot \sin \alpha_i, \quad y_{i+} = y_i + r \cdot \cos \alpha_i \quad \text{— top point.}$$

The following figure shows the trajectories of the movement of centers and extreme points of two bodies before their collision (Fig. 3).

The time moment the collision of bodies is determined by the computer simulation, according to the data presented in the calculation table (Fig. 2). New initial conditions for the movement of bodies after their collision are calculated on the basis of the laws of conservation of energy and momentum by the formulas (2), (6) (Fig. 4).

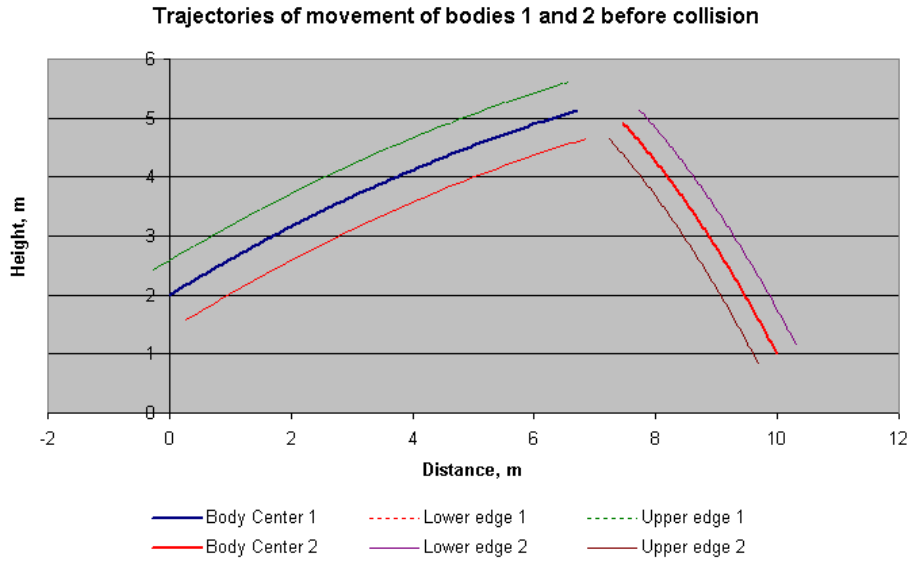
Trajectories of bodies' movement after the collision are determined similarly: the calculation scheme is copied to a new spreadsheet; new initial conditions are entered automatically; the trajectories of the bodies after the collision are added to the trajectories graphs before collision (Fig. 5).

In addition, Excel allows us to check the implementation of the laws of energy conservation and impulse according to the formulas:  $E_{ki} = \frac{m \cdot v_i^2}{2}$ ,  $E_{pi} = m \cdot g \cdot y_i$ ,

$$E_i = E_{ki} + E_{pi}; \quad p_{xi} = m \cdot v_{xi}, \quad p_{yi} = m \cdot v_{yi}, \quad p_i = \sqrt{p_{xi}^2 + p_{yi}^2} \quad \text{or as an alternative, } p_i = m \cdot v_i,$$

$$p_{xi} = p_i \cdot \cos \alpha_i, \quad p_{yi} = p_i \cdot \sin \alpha_i.$$

The calculations are presented in the Fig. 6.



**Fig. 3.** Trajectories the centers and extreme points of bodies 1 and 2 before collision

	Q	R	S	T	U	V	W	X
3	<b>Parameters of movement of bodies at the moment of collision</b>							
4	$t=$	0,4653 s	Time of collision of bodies (moment of touch of the					
5	$x1=$	6,708145 m	Coordinates of body centers at the moment of the					
6	$y1=$	5,129762 m						
7	$x2=$	7,465099 m						
8	$y2=$	4,913071 m	<b>Speed of bodies at the moment of a collision</b>					
9	$v1=$	15,08622 m/s	$v1x=$	14,41682 m/s				
10	$\alpha1=$	0,299012 radians	$v1y=$	4,444034 m/s				
11	$v2=$	8,199118 m/s	$v2x=$	-5,44789 m/s				
12	$\alpha2=$	2,297551 radians	$v2y=$	6,127485 m/s				
13								
14	<b>New speeds (defined by conservation laws)</b>							
15	Initial parameters of motion of bodies after a collision							
16	$u01x=$	1,173682 m/s	$u02x=$	21,03839 m/s				
17	$u01y=$	5,566335 m/s	$u02y=$	3,882884 m/s				
18	$u1=$	5,688727 m/s	$u2=$	21,3937 m/s				
19	$\alpha1=$	1,362987 radians	$\alpha2=$	0,182508 radians				
20		78,09339 degrees		10,45695 degrees				

**Fig. 4.** Calculations the bodies collision moment and initial conditions of movement the bodies after their collision

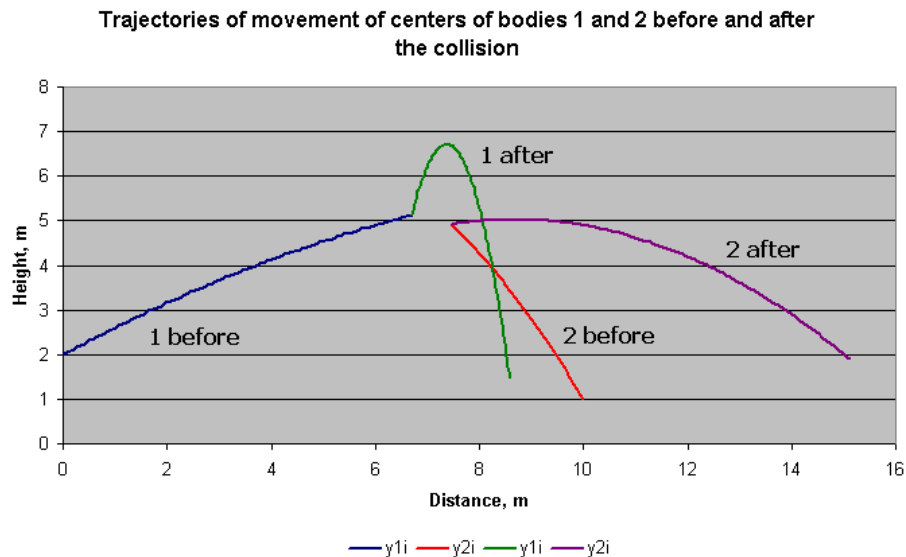


Fig. 5. Trajectories of centers the bodies 1 and 2 before and after their collision

	Q	R	S	T	U	V	W
22	<b>Checking the law of energy conservation</b>						
23	<b>Before collision</b>			<b>After the collision</b>			
24	$E_{k1} =$	227,5941	J	$E_{k1} =$	32,36181	J	
25	$E_{k2} =$	33,61277	J	$E_{k2} =$	228,8452	J	
26	$\Sigma =$	261,2068	J	$\Sigma =$	261,2068	J	
27							
28	<b>Check the law of conservation of momentum</b>						
29	<b>Before collision</b>			<b>After the collision</b>			
30	$p_{x1} =$	28,83364	kg*m/s	$p_{x1} =$	2,347364	kg*m/s	
31	$p_{y1} =$	8,888069	kg*m/s	$p_{y1} =$	11,13267	kg*m/s	
32	$p_1 =$	30,17244	kg*m/s	$p_1 =$	11,37745	kg*m/s	
33	$p_{x2} =$	-5,44789	kg*m/s	$p_{x2} =$	21,03839	kg*m/s	
34	$p_{y2} =$	6,127485	kg*m/s	$p_{y2} =$	3,882884	kg*m/s	
35	$p_2 =$	8,199118	kg*m/s	$p_2 =$	21,3937	kg*m/s	
36	$\phi_i =$	1,99854	radians	$\phi_f =$	-1,18048	radians	
37	$p =$	27,79137	kg*m/s	$p =$	27,79137	kg*m/s	
38	<b>2nd way</b>						
39	$p_x =$	23,38575	kg*m/s	$p_x =$	23,38575	kg*m/s	
40	$p_y =$	15,01555	kg*m/s	$p_y =$	15,01555	kg*m/s	
41	$p =$	27,79137	kg*m/s	$p =$	27,79137	kg*m/s	

Fig. 6. Checking the laws of energy conservation and impulse in Excel

Thus, using the constructed mathematical model and changing the input parameters of the model in the input block (Fig. 1), the students of the group E were able to perform various virtual experiments in Excel. The analysis of the obtained numerical results and graphs allowed them to comprehensively study the patterns of motion of bodies 1 and 2 before and after the collision, to establish the initial conditions of the movement of bodies in which their collisions occur, to investigate the behaviors of bodies after the collision.

## 2.4 Performing the learning task with GeoGebra (Group G)

The implementation of mathematical models in the GeoGebra environment is performed on the basis of their algebraic-geometric description [11]: the program sequentially, step by step, creates a dynamic visualization of basic mathematical objects such as a point, angle, segment, vector, circle, line. It is advisable to rely on the geometric interpretation of objects of linear algebra [3].

First, GeoGebra creates a description of the initial values of the main objects of the model.

$O_{01}(x_{01}, y_{01}), O_{02}(x_{02}, y_{02})$  – starting points of trajectories of bodies 1 and 2;

Vectors of initial velocity:

$\vec{v}_{01x} = \overrightarrow{O_{01}A_{01}}, \vec{v}_{01y} = \overrightarrow{O_{01}B_{01}}, \vec{v}_{01} = \overrightarrow{O_{01}C_{01}}; \vec{v}_{02x} = \overrightarrow{O_{02}A_{02}}, \vec{v}_{02y} = \overrightarrow{O_{02}B_{02}}, \vec{v}_{02} = \overrightarrow{O_{02}C_{02}}$ , where  
 $C_{01}(x(O_{01}) + v_{01x} \cdot mst, y(O_{01}) + v_{01y} \cdot mst), C_{02}(x(O_{02}) + v_{02x} \cdot mst, y(O_{02}) + v_{02y} \cdot mst),$   
 $A_{01}(x(C_{01}), y(O_{01})), A_{02}(x(C_{02}), y(O_{02})), B_{01}(x(O_{01}), y(C_{01})), B_{02}(x(O_{02}), y(C_{02})),$   
*mst* – scale factor that allows interactively to resize the individual objects in the GeoGebra software.

The next step is a geometric description of the dynamic characteristics of the movement of bodies:

$O_1(x_1, y_1), O_2(x_2, y_2)$  – current coordinates the canters of bodies 1 and 2; vectors of instant velocity:

$\vec{v}_{1x} = \overrightarrow{O_1A_1}, \vec{v}_{1y} = \overrightarrow{O_1B_1}, \vec{v}_1 = \overrightarrow{O_1C_1}; \vec{v}_{2x} = \overrightarrow{O_2A_2}, \vec{v}_{2y} = \overrightarrow{O_2B_2}, \vec{v}_2 = \overrightarrow{O_2C_2}$ , where  
 $C_1(x(O_1) + v_{1x} \cdot mst, y(O_1) + v_{1y} \cdot mst), C_2(x(O_2) + v_{2x} \cdot mst, y(O_2) + v_{2y} \cdot mst),$   
 $A_1(x(C_1), y(O_1)), A_2(x(C_2), y(O_2)), B_1(x(O_1), y(C_1)), B_2(x(O_2), y(C_2)).$

Vectors of forces acting on bodies 1 and 2:  $\vec{F}_{G1} = \overrightarrow{O_1F_1}, \vec{F}_{G2} = \overrightarrow{O_2F_2}$ , where  
 $F_1 = (x(O_1), y(O_1)) - m_1 \cdot g \cdot mst, F_2 = (x(O_2), y(O_2)) - m_2 \cdot g \cdot mst.$

Visualizations the bodies 1 and 2 motion trajectories are constructed according to equation (3). Changing the input parameters of the model in the GeoGebra environment is carried out interactively with the help of sliders created when you first enter the corresponding numeric values. The results of the visual representation of this model and the control block are shown in the figure in GeoGebra (Fig. 7).

In GeoGebra, the moment of bodies' collision is determined by formula (5). After the collision the body 1 and 2 took new initial velocities (6) are represented, which are represented by vectors  $\vec{u}_{1x} = \overrightarrow{O_1A'_1}, \vec{u}_{1y} = \overrightarrow{O_1B'_1}, \vec{u}_1 = \overrightarrow{O_1C'_1}; \vec{u}_{2x} = \overrightarrow{O_2A'_2}, \vec{u}_{2y} = \overrightarrow{O_2B'_2}, \vec{u}_2 = \overrightarrow{O_2C'_2}.$

Next figure (Fig. 8) shows the vectors of the instant velocity of bodies 1 and 2 at the moment of their collision ( $t = 0,46$  s) at given values of the model parameters (Fig. 1). Ibid, in the Algebra panel, the numerical values of the coordinates of the velocities are presented.

By changing the model parameters in the input block (Fig. 8), students in group G performed virtual experiments in the GeoGebra environment. The analysis of

interactive graphs in the Graphics area and the numerical results presented in the Algebra panel allowed them to investigate the movement of bodies 1 and 2 before and after their collision, to determine the initial conditions under which bodies collide and the characteristics the movement of bodies after their collision.

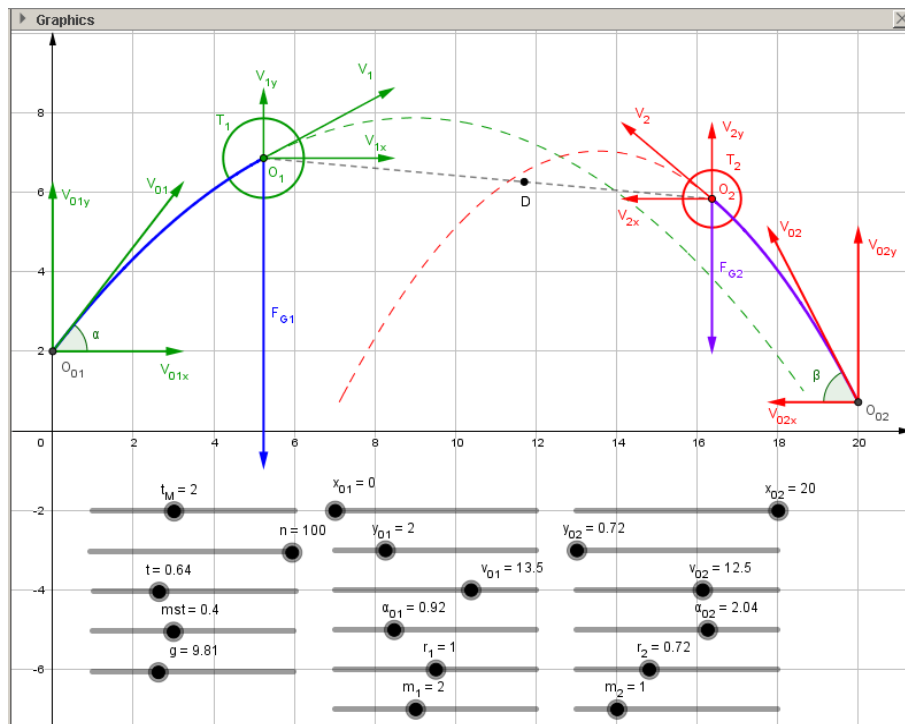
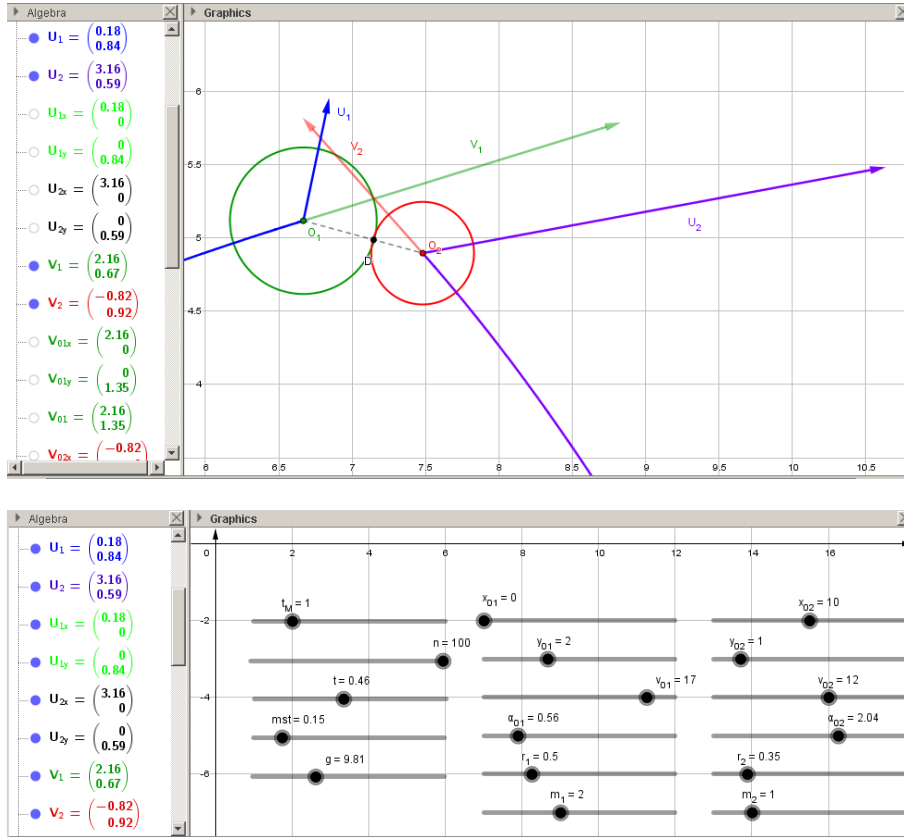


Fig. 7. Interactive model of motion and collision of two bodies in GeoGebra

To our regret, the limited scope of the article does not allow the authors to give a complete description of the methodology for using the proposed models in the educational process.

## 2.5 Performing the learning task with Excel and GeoGebra (Group EG)

The third group of students (EG) performed the training task using both Excel and GeoGebra in accordance with the methodology described above. Excel program was used mainly for numerical calculations and representation of numerical results in the form of tables. The GeoGebra program was used mainly for visual representation and analysis of dynamic motion characteristics.



**Fig. 8.** Vectors the instant velocity of bodies 1 and 2 at the moment of their collision ( $t = 0.44624$  s with the specified initial conditions)

### 3 Results

The learning outcomes of students after the experiment are shown on a 100-point scale (Table 2).

**Table 2.** Final learning outcomes of students after the experiment

Score	50-55	55-60	60-65	65-70	70-75	75-80	80-85	85-90	90-95
Group E	1	2	6	9	14	10	7	4	-
Group G	-	3	6	10	13	15	7	3	1
Group EG	-	1	3	5	10	15	9	6	3



## 4 Discussion

The prime statistical data processing results of the experiment (Table 3) are showed that the average scores in all groups (mean) exceed the corresponding figures for the two previous years (it presented at the beginning of the article). In this case the means for groups E and G were close to each other (73.4 and 73.7) but both lower than the mean of group EG (77.4). Shapiro-Wilk test result [14] is demonstrating the true of hypothesis about normal data distribution in all groups (Table 3). Analysis of variance (ANOVA) showed a statistically significant difference in average values of learning out-comes (Score/Point/Bal) in all groups ( $F = 4.1632$ ;  $p = 0.0177$ ). This case, the post-hoc comparison for means of groups E vs. G, E vs. EG, G vs. EG demonstrated that the difference between the means of groups E and G is within the statistical error (Table 4). The pair-wise post-hoc comparisons results presented in Table 5 indicate the statistical significance of the difference between the mean for group EG and the mean groups E and G.

**Table 3.** The primary statistical data processing results

Group	Valid N	Mean	Conf. -95%	Conf. +95%	Median
E	53	73,4	71,2	75,6	74
G	58	73,7	71,6	75,8	74
EG	52	77,4	75,7	79,6	77

Group	Mode	Frequency Mode	Min	Max	SD	Shapiro-Wilk test	
E	Multiple		55	90	7,95	W=0,98823	p=0,87840
G	76	5	56	91	8,06	W=0,98859	p=0,86117
EG	76	6	60	95	7,96	W=0,98956	p=0,92711

**Table 4.** The ANOVA results

	SS	df	MS	SS	df	MS	F	p
Point	528,7585	2	264,3793	10226,91	160	63,91819	4,136213	0,017724

**Table 5.** The pair-wise post-hoc comparisons results

Pair-wise post-hoc comparisons of means	E vs. G	E vs. EG	G vs. EG
LSD-test	p>0,8277	p<0,0108	p<0,0166
Duncan-test	p>0,8293	p<0,0120	p<0,0161
Tukey HSD for unequal N	p>0,9753	p<0,0276	p<0,0161

There are several probable reasons for this result need to point out. In our opinion, the visualization trajectories the mechanical movement of bodies in the form of Excel graphs contributes to the formation of “engineering thinking”, in particular, intuitive ideas about the movement of bodies and the conditions of their collision from initial conditions and other parameters. This allows students to acquire skills in meaningful adjustments to process input parameters in order to achieve the desired simulation

result. However, the standard features of Excel do not allow to visualize changes in the values of instantaneous velocities and directions of movement of bodies along their trajectories. Therefore, the use of Excel in teaching does not create sufficient conditions for the formation of skills of an «intuitive» analysis of dynamic characteristics of motion by numerical data (Fig. 2), requires developed abstract thinking, formed skills of “physical thinking”, and takes more time than visual analysis.

Instead, the use of GeoGebra provides faster formation of intuitive spatial representations of students in the analysis of dynamic characteristics of motion. This was manifested, in particular, during discussion with students of a qualitative picture of the characteristics of the movement of two bodies before and after their collision and interaction of bodies at the time of the collision. In our opinion, this has become possible thanks to the dynamic visualization of vector motion characteristics. After completing the proposed study with GeoGebra, students easily formulated meaningful answers to questions such as “How will the shape of the trajectory and the direction of movement of bodies change before and after their collision, depending on the initial characteristics of motion, mass and body size?”. Most students of group G during computer experiments with the model, showed interest and creative approach, independently put forward and tested their own hypotheses, based mainly on geometric representations. After a brief discussion, guided by the instructional materials, they were able to describe and implement the corresponding mathematical model in the GeoGebra environment independently.

The disadvantage of using GeoGebra to study the basics of modeling is the inconvenience of evaluating simulation results in a numerical dimension. The use of GeoGebra during the training of OMM promotes the formation of intuitive spatial representations important for specialists in the engineering field, but does not provide sufficient level of formation of the skills of numerical evaluation of the characteristics of the phenomenon or simulated process. That is why, in our opinion, there is no significant difference between the learning outcomes in groups E and G. Simultaneous use of Excel and GeoGebra compensates for these shortcomings, and therefore provides better learning outcomes.

## 5 Conclusion

Results of the study get conclusion that the simultaneous use of Excel and GeoGebra improved the academic achievement of students with BMM. This is indicated by the statistically significant difference between the average results of students' academic achievement, shown in Table 3 confirmed with the results of Table 4 and Table 5. Consequently, as our results show, the hypothesis that the visualization of modeling results improves students' knowledge of the basics of mathematical modeling has been confirmed.

In the next we plan to reproduce this study by offering students more sophisticated learning tasks, in particular, to construct models of inelastic and semi-elastic collision of two bodies, which should take into account air resistance, shape and rotation of the bodies, their gravitational and / or electrostatic interactions, etc.

## References

1. Arbain, N., Shukor, N.A.: The Effects of GeoGebra on Students Achievement. *Procedia - Social and Behavioral Sciences*. **172**, 208–214 (2015). doi:10.1016/j.sbspro.2015.01.356
2. Aulakh, M., Khan, Z.M., Sana, A.: Learning styles and their impact on the nursing students' perception: across-sectional descriptive research. *Indo American Journal Of Pharmaceutical Sciences*. **05(08)**, 8129–8134 (2018). doi:10.5281/zenodo.1406293
3. Caligaris, M., Rodríguez, G., Laugero, L.: Learning Styles and Visualization in Numerical Analysis. *Procedia - Social and Behavioral Sciences*. **174**, 3696–3701 (2015). doi:10.1016/j.sbspro.2015.01.1101
4. Caligaris, M.G., Schivo, M.E., Romiti, M.R.: Calculus & GeoGebra, an Interesting Partnership. *Procedia - Social and Behavioral Sciences*. **174**, 1183–1188 (2015). doi:10.1016/j.sbspro.2015.01.735
5. Fikhtengolts, G.M.: *Course of differential and integral calculus*. **2**. Moscow (1970)
6. Flehantov, L., Antonets, A.: Computer simulation the mechanical movement body by means of MathCAD. *Information technologies in education*. **1(30)**, 97–109 (2017). doi:10.14308/ite000622
7. Flehantov, L.O., Ovsienko, Yu.I.: Differentiated approach in teaching the basics of mathematical modeling with MS Excel for students of agricultural universities. *Information Technologies and Learning Tools*. **54(4)**, 165–182 (2016). doi:10.33407/itlt.v54i4.1407
8. GeoGebra | Free Math Apps – used by over 100 Million Students & Teachers Worldwide. <https://www.geogebra.org> (2019). Accessed 21 Feb 2019
9. Horda, I.M., Flehantov, L.O.: Computer modelling of process of the mechanical motion of body with the help of MS Excel means. *Information Technologies and Learning Tools*. **47(3)**, 99–109 (2015). doi:10.33407/itlt.v47i3.1245
10. Hryb'iuk, O.O., Dem'ianenko, V.M., Zhaldak, M.I., Zaporozhchenko, Yu.H., Koval, T.I., Kravtsov, H.M., Lavrentieva, H.P., Lapinskyi, V.V., Lytvynova, S.H., Pirko, M.V., Popel, M.V., Skrypka, K.I., Spivakovskiy, O.V., Sukhikh, A.S., Tataurov, V.P., Shyshkina, M.P.: *Systema psikhologo-pedahohichnykh vymoh do zasobiv informatsiino-komunikatsiinykh tekhnolohii navchalnoho pryznachennia (System of psychological and pedagogical requirements to ICT learning tools)*. Atika, Kyiv (2014)
11. Hall, J., Lingefjård, T.: *Mathematical Modeling: Applications with GeoGebra*. John Wiley & Sons, Hoboken (2016)
12. Valdés y Medina, E.G., Valdés, L.M.: Dynamic Models as Change Enablers in Educational Mathematics. *Procedia - Social and Behavioral Sciences*. **176**, 923–926 (2015). doi:10.1016/j.sbspro.2015.01.559
13. Ramirez-Velarde, R., Alexandrov, N., Perez-Cazares, R., Barba-Jimenez, C.: Mathematical Modelling Based Learning Strategy. *Procedia Computer Science*. **51**, 1694–1704 (2015). doi:10.1016/j.procs.2015.05.307
14. Razali, N.M., Wah, Y.B.: Power comparisons of Shapiro-Wilk, Kolmogorov-Smirnov, Lilliefors and Anderson-Darling tests. *Journal of Statistical Modeling and Analytics*. **2(1)**, 21–33 (2011)
15. Semerikov, S.O., Teplytskyi, I.O., Yechkalo, Yu.V., Kiv, A.E.: Computer Simulation of Neural Networks Using Spreadsheets: The Dawn of the Age of Camelot. In: Kiv, A.E., Soloviev, V.N. (eds.) *Proceedings of the 1st International Workshop on Augmented Reality in Education (AREdu 2018)*, Kryvyi Rih, Ukraine, October 2, 2018. *CEUR Workshop Proceedings*, vol. 2257, pp. 122–147. <http://ceur-ws.org/Vol-2257/paper14.pdf>. Accessed 21 Mar 2019

16. Smetackova, I.: Gender Stereotypes, Performance and Identification with Math. *Procedia - Social and Behavioral Sciences*. **190**, 211–219 (2015). doi:10.1016/j.sbspro.2015.04.937
17. Soloviov, V.M., Semerikov, S.O., Teplytskyi, I.O.: Instrumentalne zabezpechennia kursu kompiuternoho modeliuвання (Instrumental computer simulation courseware). *Kompiuter u shkoli ta simi*. 4, 28–31 (2000)
18. Spivakovsky, A., Petukhova, L., Spivakovska, E., Kotkova, V., Kravtsov, H.: Three-Subjective Didactic Model. In: Ermolayev V., Mayr H.C., Nikitchenko M., Spivakovsky A., Zholtkevych G. (eds) *Information and Communication Technologies in Education, Research, and Industrial Applications. ICTERI 2013. Communications in Computer and Information Science*, vol. 412, pp. 252–273. Springer, Cham (2013). doi:10.1007/978-3-319-03998-5\_13
19. Teplytskyi, I., Semerikov, S.: Kompiuterne modeliuвання mekhanichnykh rukhiv u seredovysychi elektronnykh tablyts (Computer modeling of mechanical movements in an spreadsheets environment). *Fizyka ta astronomiia v shkoli*. 5, 41–46 (2002)
20. Teplytskyi, I.O., Semerikov, S.O.: Kompiuterne modeliuвання absoliutnykh ta vidnosnykh rukhiv planet Soniachnoi systemy (Computer simulation of absolute and relative motions of the planets the Solar system). *Zbirnyk naukovykh prats Kamianets-Podilskoho natsionalnoho universytetu. Seriiia pedahohichna*. **13**, 211–214 (2007)
21. Teplytskyi, I.O., Semerikov, S.O.: Na perekhresti ekolohii, matematyky, informatyky y fizyky (At the intersection of ecology, mathematics, computer science and physics). *Zbirnyk naukovykh prats Kamianets-Podilskoho natsionalnoho universytetu. Seriiia pedahohichna*. **18**, 34–37 (2012)
22. Teplytskyi, I.O., Teplytskyi, O.I., Humeniuk, A.P.: Seredovysycha modeliuвання: vid zaminy do intehratsii (Modeling environments: from replacement to integration). *New computer technology*. **6**, 67–68 (2008)
23. Teplytskyi, I.O.: *Elementy kompiuternoho modeliuвання (Elements of computer simulation)*. 2<sup>nd</sup> edn. KSPU, Kryvyi Rih (2010)

# Computer Simulation as a Method of Learning Research in Computational Mathematics

Lyudmila Bilousova<sup>[0000-0002-2364-1885]</sup>, Oleksandr Kolgatin<sup>[0000-0001-8423-2359]</sup>  
and Larisa Kolgatina<sup>[0000-0003-2650-8921]</sup>

H. S. Skovoroda Kharkiv National Pedagogical University,  
Alchevskyyh Str., 29, Kharkiv, Ukraine  
lib215@ukr.net

**Abstract.** The paper deals with a problem of students' independent work through learning research. By solving research problems students gain experiences in a way closest to the real scientific study. A student does not receive the "ready" knowledge and decisions, but a teacher puts for him the goal, the cognitive problem that this student should solve during independent research activity. We suggest appropriate computer models in Mathcad environment (dynamic support synopsis) to provide such learning research in the "Methods of Computing" course. Students research some problems of global polynomial interpolation, spline interpolation, choose the appropriate function for approximation, verify the efficiency (accuracy and convergence rate) of some methods of numerical calculation of integrals and solving of non-linear equations. The results of approbation of this learning methods in the training process of H. S. Skovoroda Kharkiv National Pedagogical University are shown and discussed. The efficiency of our approach was checked with use of such criteria: completeness of knowledge and depth of knowledge. Statistical analysis of obtained data shows advisability of implementation of learning research in training process.

**Keywords:** Computer Simulation, Students' Independent Work, Computational Mathematics.

## 1 Introduction

The existence of the wide software spectrum should be reflected in the technique of the numerical methods learning by future experts in applied fields of science and technology. The main questions of teaching are the following: interpretation of the whole picture of possible approaches to numerical problem solving; realization of the idea and peculiarities of each method; conditions of the method application; advantages and disadvantages in comparison with other methods; determination of problems classes, for which the method can be the most efficient. We should mention that theoretical analysis of possibilities of using some methods becomes very complicated in practice in many cases, so the investigator's intuition is considered to be very important in process of the proper method choice. All these facts can explain the necessity of carrying out the special teaching methods, which will give the future

specialists the opportunity to gain their own experience in the use of different methods and to make proper conclusions.

The realization of these methods is a very difficult task and is determined by the role of computers in the process of teaching. According to the tradition, computer is considered as a calculating device in the process of learning of numerical methods, so practical work in this course is transformed to programming where certain algorithms of methods are translated into one or another language. The availability of software for supporting professional mathematical activity directs us to transfer the practical work to the higher level by the use of computers as a means of scientific research. In this case, we can avoid the necessity of programming, but the process of calculation is hiding from a user and it can reduce the laboratory work to mindless copying the numbers from the computer screen. It is possible to give the laboratory work real educational and research character only by means of the problem situation that can fill in the whole work with purport by putting its final aims and determining the leading questions. We have prepared our guidebook for students – future teachers to put such problem situation and show the steps of problem solving [1].

The fundamentals of numerical methods have been published in scientific and education books of well-known authors [2], [3], [4], [5], [6], [7], [8], [9] etc. Modern applications of numerical methods are undoubtedly connected with using computers. So computer-based environment became a significant element in teaching numerical methods. There are enough scientific works in the field of mathematics education that use a computer-based environment to show the calculation procedure at using numerical methods, for example, the authors [10] use MS Excel “... to perform numerical integration, specifically trapezoidal rule and Simson’s rule ...” and the procedure of generation of Lagrange’s interpolation polynomial [10]. The other direction of studies in the field of education in numerical methods is to use special teaching software [11]. Graphical visualization is another interesting approach to this difficult educational problem. Thus, the authors [12] take attention for visualization of complicated iterative and recursive process for solving non-linear equations and use GeoGebra software that “... makes possible to deal with these methods by means of their geometrical interpretation and to visualize their behavior and procedure” [12]. Last time, great attention is paid to particularities of using the numerical methods in some non-standard conditions [1], [9]. Therefore, teaching methods, which oriented on using computer-based environment for learning research of these particularities, for deeper mastering in computational mathematics, need in further development.

**The goal** of this work is to verify the methods of learning research organizing with suggested computer-based models for numerical methods investigation in Mathcad environment (dynamic support synopsis).

## **2 Curricula and objectives**

The purpose of teaching the discipline “Methods of Computing” at Physics and Mathematics department of the H. S. Skovoroda Kharkiv National Pedagogical University is to familiarize students with the general characteristics of the basic

methods of numerical solution of applied tasks based on the construction of mathematical models; to form students skills in mathematical-oriented computer environments and the ability to conduct computational experiments in these environments; to equip students with research skills and analysis skills; to provide students with the skills of competent use of numerical methods in practice.

The main objectives of studying the discipline “Methods of computing” are the such:

- to reveal the place and significance of knowledge on numerical methods in general and vocational education; to show psychological and pedagogical aspects of mastering the subject; to establish relationship of the discipline “Methods of computing” with other educational subjects; to show the practical significance of numerical methods, mathematical modeling, computational experiment, their applicability to solving of humanitarian, technical and scientific problems; to present examples of realization of great opportunities that open the efficient use of computers;
- to provide future teachers with grounded study of the concepts and methods of computing that can be used by them in the process of teaching some topics of the school courses of mathematics and computer science, familiarizing pupils with elements of numerical methods, conducting optional classes in secondary schools;
- to form students with sufficient knowledge, skills and abilities, necessary for the practical conduct of educational work in the secondary schools with the wide use of modern information technologies.

According to the requirements of the educational-professional program, students must know the main stages of solving the problems on a computer, the basic numerical methods for solving mathematical problems and the peculiarities of its computer-based implementation. Students should be able substantiate the choice of a numerical method for solving a mathematical problem, realize the method algorithm using the programming languages or some specialized computer-based environment (such as Excel, Mathcad, etc.), perform the necessary calculations and analyze the obtained results.

According to curricula, students study such chapters of numerical methods: Elements of the Error Theory, Functions Approximation (Polynomial Interpolation, Spline Interpolation, Least Squares Method), Numerical Integration, Solution of One-Variable Equations, Solution of Systems of Linear Equation, First-Order Differential Equation and its Systems. In this paper we focus on approximation and integration problems.

### **3 Theoretical background**

There are two main tasks at the statement of the approximation problem:

- Choosing of approximation function;
- Choosing the criterion of proximity of the function.

Different kinds of approximation may emerge depending on this choice. One case of approximation problem is the polynomial interpolation problem, where it is required that interpolating polynomial should take the same values as the interpolated function at the given points  $x_0, x_1, \dots, x_n$  of the interval  $[A; B]$ . A system of linear equations should be solved to obtain the coefficients of polynomial and some useful formulas are well known (Lagrange's and Newton's polynomial interpolation formulas). Students study these formulas and should use it in practice, this part of educational material is reproductive. The interpolation polynomial of degree not above  $n = N-1$  always can be construct, if  $N$  interpolation nodes are given. But problem is in error estimation of approximation the given function by polynomial. To solve this problem a student should work on high levels of cognitive activity.

We may get the error estimation of the function approximation by interpolation polynomial:

$$|R_n(x)| \leq \frac{M_{n+1}}{(n+1)!} |x - x_0| |x - x_1| \dots |x - x_n|, \text{ where } M_{n+1} = \max_{x \in [x_0; x_n]} |f^{(n+1)}(x)|.$$

This formula for polynomial interpolation error estimation can be simplified for equidistant nodes:

$$|R_n(x)| \leq \frac{M_{n+1}}{(n+1)!} h^{n+1} |q(q-1) \dots (q-n)|.$$

Thus,  $|R_n(x)| = O(h^{n+1})$ , that is interpolation error should decrease as  $h^{n+1}$  with decreasing of the interpolation step. But many factors affect at this error:

- the form of the function  $f(x)$ , in particular, the value of its derivative of the  $(n+1)$  order;
- the interpolation nodes arrangement on the interval  $[A; B]$  and the size of the interval.

The factor of the function form is very essential, as an example, we can remember the classical Runge's function, which have growth of derivatives with its order so high that the interpolation of this function with polynomial of high degree leads to unacceptable error growth. It is not easy to analyze the function derivative on all interval  $[A; B]$  in many practical cases. In addition, the total error of calculation of the function value according to an interpolation formula doesn't only consist in interpolation error (method error) but includes irremovable error, which is connected with inaccuracy of ascertainment of the function values in nodes and calculation error. So we should provide the student with some competence, may be intuition, for an expedient choice between global interpolation, piecewise interpolation and spline interpolation as well as choice of nodes arrangement. Such competence can be formed only by own experience in study of interpolation of different functions in different conditions, that is, practical solving problems or learning research.

A similar situation takes place with the numerical integration, because its error also depends on the form of the function at the interval  $[A; B]$ . We should provide our students with competences to make an expedient choice between global or piecewise



quadrature formulas, to recommend the order of the quadrature formula, to use Newton-Cotes or Gaussian formulas, to estimate the real accuracy of the integration.

#### **4 Methods of students' learning research management**

The laboratory works on the discipline "Methods of Computing" is constructed as a series of learning research of gradually increasing complexity. Students do not obtain ready-made knowledge, ready decisions, but the problem is posed that becomes a basis of students' independent research activity. Gradual complication of the content of the cognitive tasks, which are proposed for experimental study, is an important element in organizing such laboratory practice. The possibility of using the research method in the laboratory practice is conditioned by the advent and improvement of professional-oriented environments that provide the students with comfortable tools for the computational experiments. As a basis for the learning research in numerical methods we have taken the Mathcad environment, which is widely used to solve applied mathematics problems, and, at the same time, has a number of certain attractive qualities that makes it convenient for use in learning: intuitive interface, developed system menu and help, ability to input textual, symbolic and graphic information in any place of the workspace, fairly flexible embedded programming language, etc. [13].

To provide students' learning activity we have designed some models that realize certain algorithms of numerical methods in Mathcad environments. The interface of these models is designed as a set of special electronic pages that play the role of dynamic support synopsis (DSS) that is convenient for entering the input data of the task and structured displaying the result according to algorithm. Thus, the student actually receives a virtual laboratory for a computational experiment.

Management of the learning research was carried out according to the following scheme [13]:

- setting objectives;
- providing observation and accumulation of experimental data;
- doing evaluation and comparative analysis of the obtained data;
- predicting characteristics of the investigated method;
- formulating hypotheses;
- studying the features of the method being studied;
- analyzing the received data;
- correcting the hypothesis;
- summarizing the results of work and formulating conclusions.

We have developed didactical support for the laboratory works in the form of plans-reports to provide meaningful and targeted student's activities and to ensure the achievement of the predicted learning effect. Plans-reports are built according to a single scheme and consist of two parts – informative and instructional. The informative part contains the subject of the work, its purpose, description of the software, characteristic of entered and displayed numeric and graphic data. The instructional part contains the order of execution of the work, where its key points are marked and fixed.

To motivate the student to a study, he is initially offered a chain of appropriately selected questions. Then the work is carried out according to the proposed plan, which defines the stages of the study, tasks that are solved at each stage, experimental material to be obtained, the form of its submission, etc. As students gain experience, the instructions to them become less detailed. Some experiments the student must plan, put and implement on their own. Individual variants of sets of tasks are suggested to each student to perform the laboratory work. These tasks are selected to show features of every algorithm that are studied and correspond to the purpose of the work [13]. The results of the work are proposed to be done in the form of conclusions, outlines of which with a greater or lesser detailing are fixed in the plan-report. It helps the student to record the results of work, to structure them, to pay his attention to those moments of research that can remain unnoticed.

## 5 Learning research in polynomial interpolation

We suggest students to investigate the problems of polynomial interpolation during three laboratory works:

- Lagrange's interpolation formula – the students study the influence of interpolation polynomial degree on the accuracy of global interpolation for different functions at the given interval  $[A; B]$ . Each student works with the individual set of functions, including functions with great growth of its derivative of high orders, polynomials, even and odd functions etc. An example of such student's investigation are shown in Table 1. Part 2 of this laboratory work is devoted to influence of the interpolation nodes localization on the interpolation accuracy and using Chebyshev's polynomial roots as nodes of interpolation;
- Newton's interpolation formula – the students are introduced with technics of building the polynomial across the table of function values as well as the methods of accuracy control and its limitation in "bad" situations;
- Piecewise interpolation, splines – the students operate with the various kind of interpolation models and get an experience in choice the appropriate method in different cases.

The last laboratory work is integrative. So let analyze it more detail. The aim of the work is to investigate interpolation of the function using piecewise interpolation polynomial and cubic spline. The software (DSS) contains models of spline, global and piecewise polynomial interpolation and gives the students possibilities to choose parameters of this model easy (Fig. 1, 2). Students entered the input data:  $A, B$  are the ends of the interpolation interval;  $f(x)$  is the interpolated function.

At the beginning of the work students discuss some leading questions to actualize theoretical knowledge and formulate problems for experimental study:

- Are there cases, when increasing of the global interpolation polynomial degree leads to increasing, but not decreasing of the interpolation error?

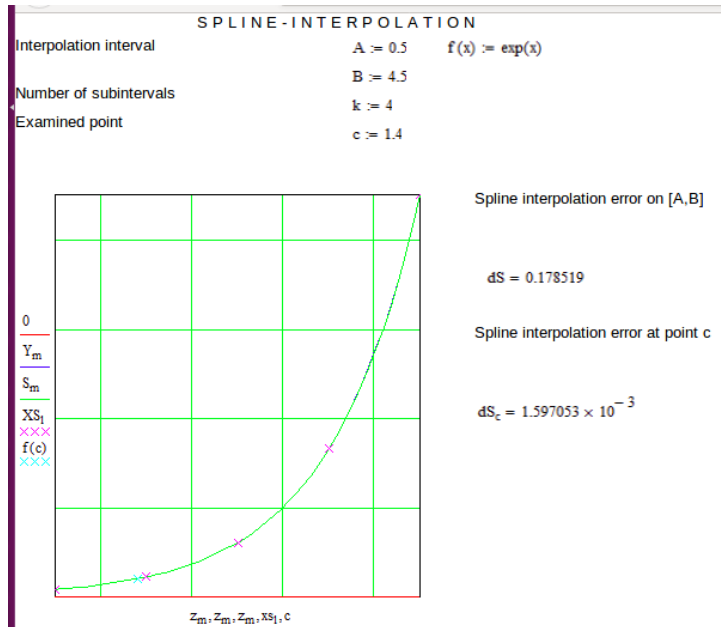
- What conditions does the global interpolation polynomial become useless for function approximation under?
- What factors limit the interpolation polynomial degree in practice?
- How does the number of interpolation nodes, which have been taken into account, influence on the computational complexity with global, piecewise polynomials and spline interpolation?
- How does the number of interpolation nodes, which have been taken into account, influence on the volume of data, which must be kept for calculation of the value of global or piecewise interpolation polynomials and spline?
- What are the differences between the function approximation by piecewise interpolation with cubic polynomials, global polynomial interpolation and cubic spline interpolation? Consider cases, when there are  $3m+1$  (where  $m = 1, 2, \dots$ ) nodes on the interpolation interval.
- Can one forecast such situations, when it is necessary to prefer the global interpolation polynomial, piecewise interpolation polynomials or spline?

**Table 1.** Student's investigation of influence of the global polynomial degree  $n$  on interpolation accuracy

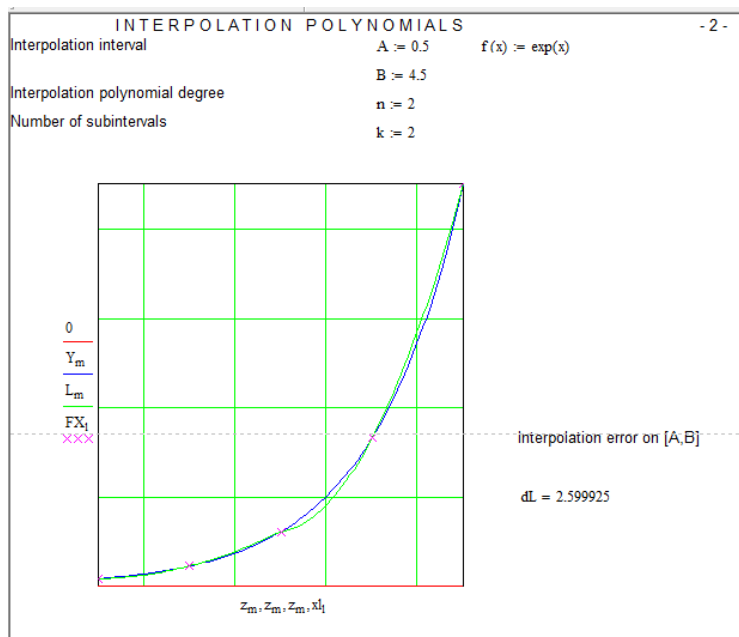
$n$	Error of interpolation in cases:					
	$e^x$ [0.5; 1.5]	$1/x^2$ [0.5; 1.5]	$2x^4 - x^3 + 3x^2 - x + 1$ [-1; 1]	$\frac{1}{1 + 25x^2}$ [-1; 1]	$\sin x$ [-2; 2]	$\cos x$ [-2; 2]
1	0.35	1.4	5.1	0.96	0.39	1.5
2	0.024	0.48	0.87	0.64	0.39	0.14
3	$1.6 \cdot 10^{-3}$	0.18	0.40	0.71	$3.5 \cdot 10^{-2}$	0.11
4	$8.7 \cdot 10^{-5}$	0.065	$1.0 \cdot 10^{-15}$	0.44	$2.5 \cdot 10^{-2}$	$7.4 \cdot 10^{-3}$
5	$4.4 \cdot 10^{-6}$	0.025	$3.6 \cdot 10^{-15}$	0.30	$1.4 \cdot 10^{-3}$	$5.3 \cdot 10^{-3}$
6	$2.0 \cdot 10^{-7}$	$9.2 \cdot 10^{-3}$	$1.8 \cdot 10^{-15}$	0.61	$9.7 \cdot 10^{-4}$	$2.2 \cdot 10^{-4}$
7	$7.9 \cdot 10^{-9}$	$3.6 \cdot 10^{-3}$	$3.6 \cdot 10^{-15}$	0.25	$3.4 \cdot 10^{-5}$	$1.6 \cdot 10^{-4}$
8	$2.9 \cdot 10^{-10}$	$1.4 \cdot 10^{-3}$	$4.5 \cdot 10^{-15}$	1.0	$2.4 \cdot 10^{-5}$	$4.5 \cdot 10^{-6}$
9	$9.4 \cdot 10^{-12}$	$5.1 \cdot 10^{-4}$	$6.2 \cdot 10^{-15}$	0.28	$5.4 \cdot 10^{-7}$	$3.2 \cdot 10^{-6}$
10	$2.8 \cdot 10^{-13}$	$2.0 \cdot 10^{-4}$	$8.9 \cdot 10^{-15}$	1.5	$3.8 \cdot 10^{-7}$	$6.2 \cdot 10^{-8}$

According to recommendations each student investigate global and piecewise polynomial interpolation and spline interpolation for given individual set of function. Students construct the global interpolation polynomial, piecewise interpolation polynomials of different degree and spline, using a fixed set of interpolation nodes  $N$  for the given functions. They find the error of each function approximation.

Then the students use the necessary number of interpolation nodes to provide given accuracy ( $10^{-4}$ ) of function approximation with spline, global and piecewise interpolation polynomial of the degree  $n = 2, 3, 4, 5$ . The example of such investigation is shown in the Table 2. Students also investigate dependence of approximation accuracy at a fixed point from the number of considered nodes from a fixed set of nodes for spline interpolation.



**Fig. 1.** Interface of the spline interpolation model



**Fig. 2.** Interface of the piecewise and global polynomial interpolation model

**Table 2.** Student's investigation of the number of nodes, which provide the given accuracy of interpolation

Approximation polynomial		Number of subintervals	Number of considered nodes	Interpolation error
type	degree			
$f(x) = e^x$ , interpolation interval [0.5; 4.5]				
Global interpolation polynomial	9	1	10	$5.5 \cdot 10^{-5}$
Piecewise interpolation polynomial	2	76	153	$9.9 \cdot 10^{-5}$
	3	19	58	$8.4 \cdot 10^{-5}$
	4	8	33	$6.7 \cdot 10^{-5}$
Spline	3	28	29	$9.6 \cdot 10^{-5}$
$f(x) = \frac{1}{1+25x^2}$ , interpolation interval [-1; 1]				
Global interpolation polynomial	Necessary accuracy was not reached; interpolation error increases with increasing the interpolation polynomial degree			
Piecewise interpolation polynomial	2	71	143	$1.0 \cdot 10^{-4}$
	3	32	97	$8.7 \cdot 10^{-5}$
	4	17	69	$5.0 \cdot 10^{-5}$
	5	14	71	$6.0 \cdot 10^{-5}$
Spline	3	27	28	$9.3 \cdot 10^{-5}$
$f(x) = \sin x^2$ , interpolation interval [-3; 3]				
Global interpolation polynomial	Necessary degree of interpolation polynomial exceeds 20, calculation was stopped because the time is beyond			
Piecewise interpolation polynomial	2	140	281	$1.0 \cdot 10^{-4}$
	3	53	160	$9.6 \cdot 10^{-5}$
	4	26	105	$9.4 \cdot 10^{-5}$
	5	17	86	$9.6 \cdot 10^{-5}$
Spline	3	81	82	$9.9 \cdot 10^{-5}$

As a combined result of the investigations, students formulate the conclusions.

## 6 Learning research in numerical integration

Numerical integration is built on the polynomial interpolation of the function. So, all competences that students obtained, when they studied the polynomial interpolation, are the basic and should be actualize. The aim of the students' learning research is to investigate effectiveness of Gauss quadrature formulas in comparison with Newton-Cotes formulas. At the first, students investigate the application of composite Newton-Cotes quadrature formulas and formulate conclusions about influence of the integration step and the degree of the interpolation polynomial that is used for quadrature formula on the integration error. Also, they use Runge's rule for integration error estimation and investigate the limits of its applicability. Then students make a comparative analysis of composite formulas of not high order of accuracy (trapezoid formula and Gauss formula with one node) and composite or single formulas of high order of accuracy (Newton-

Cotes formula using interpolation polynomial of 8-th order and Gauss formula with 8 nodes). Leading questions on this second stage of the work are the such:

- Will the choice of integration nodes influence on the error of integral calculation? What is a level?
- How can we find out nodes location at integration by Gauss formulas?
- Will the error be sensible to slight error of node position from optimal?
- When is Gauss formula required to be used? Are there any occasions, when it is not possible to use it?
- What occasions need to use composite Gauss formulas?

Appropriate DSS (dynamic support synopsis) are designed on the base of models of numerical integrating with Gauss and Newton-Cotes quadrature formulas. One page of DSS (the last) is shown in Fig. 3.

Gauss Formula and Newton-Cotes Formulas of Different Order of Accuracy			
Limits of integration :		a := 0.5 b := 2.5	Integrand: f(x) := exp(x)
Integral value (calculated by MathCAD):		I <sub>0</sub> = 10.533773	
Quadrature Formula	Number of subintervals, m	Approximated integral value	Error of integration
Trapezoid formula	m := 16	I <sub>N1</sub> = 10.547485	I <sub>0</sub> - I <sub>N1</sub>   = 0.013712
Mean rectangle formula	m := 2	I <sub>G1</sub> = 10.526918	I <sub>0</sub> - I <sub>G1</sub>   = 6.854801 × 10 <sup>-3</sup>
Newton-Cotes formula, built on interpolation polynomial of 8 <sup>th</sup> degree		I <sub>N8</sub> = 10.533773	I <sub>0</sub> - I <sub>N8</sub>   = 5.988099 × 10 <sup>-12</sup>
Gauss formula that is constructed on 8 nodes		I <sub>G8</sub> = 10.533773	I <sub>0</sub> - I <sub>G8</sub>   = 8.881784 × 10 <sup>-15</sup>

**Fig. 3.** Interface of the model for numerical integration

Results of computational experiments are collected in tables, forms of which are suggested to the students in the courseware. One of such table with student's results are shown (Table 3).

The final students' conclusions are connected with such numerical integration features:

- choice of the quadrature formula at limited number of nodes of integration;
- difference between Gauss formula and Newton-Cotes formula by construction;
- comparison of accuracy of Gauss and Newton-Cotes quadrature formulas;

- sensitiveness of integration error by Gauss formulas to accuracy of determining the nodes;
- functions, for which high order quadrature formulas are recommended;
- choice of the quadrature formula for numerical integrating of given function at given conditions;
- situations, where the error of applied numerical integration formula turned out to be comparable with calculation error.

**Table 3.** Student's investigation of the accuracy of various methods of numerical integration

Quadrature formula	$N$	$m$	Error of integral calculation		
			$\int_{0.5}^{2.5} e^x dx \approx 10.53377$	$\int_{0.5}^{2.5} \frac{dx}{x^2} = 1.6$	$\int_{-1}^1 \frac{dx}{1+25x^2} \approx 0.549360$
$I_{N1}$	9	8	0.055	0.079	0.0075
$I_{G1}$	8	8	0.027	0.038	0.0078
$I_{N8}$	9	1	$5.5 \cdot 10^{-9}$	0.0022	0.25
$I_{G8}$	8	1	$8.9 \cdot 10^{-15}$	$7.2 \cdot 10^{-6}$	0.041
$I_{N1}$	17	16	0.014	0.020	$1.3 \cdot 10^{-4}$
$I_{G1}$	16	16	0.0069	0.010	$4.2 \cdot 10^{-5}$
$I_{N8}$	17	2	$6.0 \cdot 10^{-12}$	$5.8 \cdot 10^{-5}$	0.001
$I_{G8}$	16	2	$7.1 \cdot 10^{-15}$	$2.2 \cdot 10^{-8}$	$3.0 \cdot 10^{-5}$

## 7 Results of the pedagogical experiment and discussion

In order to confirm the idea of using learning research with DSS in the study of numerical methods, a pedagogical experiment was carried out on the basis of H. S. Skovoroda Kharkiv National Pedagogical University in the process of teaching the discipline "Methods of Computing". The sample population was created by students of the III-IV year of the Physics and Mathematics Department. As a result of this experiment, there was fixed in 1999 that educational discipline "Methods of Computing" became more significant, more informative and interesting, it became possible to expand the set of methods that are considered. Students' activity and motivation increased, it was increased completeness of knowledge, depth of knowledge, research competency. Statistical analysis of obtained data showed advisability of implementation of learning research in training process [14].

To obtain new data we design the test of 57 items for yes/no answers for checking the completeness of knowledge in function approximation. The problems of this test items were reproductive, so we estimate the student's completeness of knowledge as

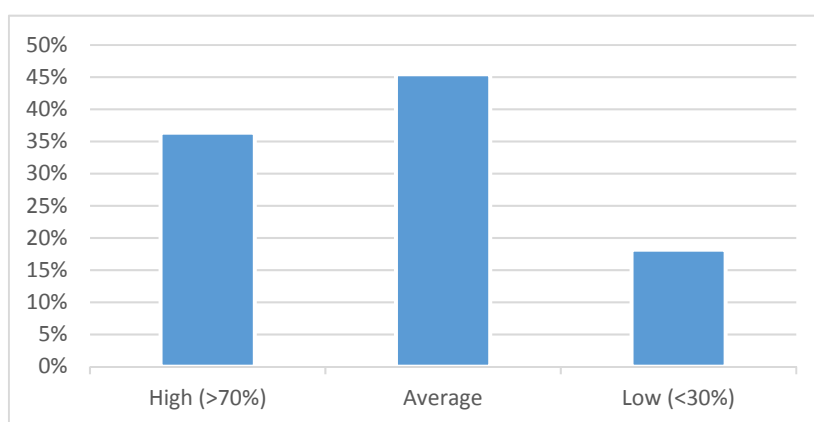
the ratio of the correct answers number to the number of item in the test. All students (11 future teachers of informatics) show the completeness of knowledge above 60%. But some test items were correctly answered by all students, these items cannot be used for pedagogical measurements. We also extract the items with not satisfactory discrimination and obtain the test of 18 items for measurement of learning achievements in the approximation (Table 4). According to the results, its reliability was estimated with Cronbach alpha as  $\alpha=0.91$ . To check the depth of knowledge, the students were suggested with two problems for full answer: 1) to characterize the influence of global interpolation polynomial order on the interpolation error; 2) to characterize the conditions of using the global polynomial interpolation, piecewise polynomial interpolation, spline interpolation and least square approximation. Depth of knowledge was estimated as a part of essential conditions of expedient application of interpolation formulas that the student shows in the answer. The results are shown in Fig. 4.

**Table 4.** Test Items Specification

Test Item	Correct answer	Index of difficulty	Correlation with the test score
Newton interpolation formula is more convenient for calculating the values of a function given by a table	Yes	0,91	0,28
Spline gives a piecewise-continuous polynomial of the second degree	No	0,91	0,21
Spline is a cubic polynomial between each pore of neighboring nodes	Yes	0,91	0,21
The replacement of the function by an interpolation polynomial is used for numerical differentiation	Yes	0,82	0,37
The approximating function for the least squares approximation is chosen so that the sum of the deviations of the function from the given points should be less than the specified EPS	No	0,82	0,66
The approximating function for the least squares approximation is chosen so that the sum of the squares of the deviations of the function from the given points is minimal	Yes	0,82	0,52
In interpolation nodes, the value of the interpolation polynomial and the value of the interpolated function differ in absolute value no more than a given EPS	No	0,73	0,75
Newton interpolation formula provides less interpolation error than the Lagrange formula	No	0,73	0,75
The approximating function for the least squares approximation is chosen so that it passes through all given points	No	0,73	0,71
The approximating function for the least squares approximation is chosen so that the largest deviation of the function from the given points is less than the given EPS	No	0,73	0,42



Test Item	Correct answer	Index of difficulty	Correlation with the test score
In the case of approximation by the method of least squares, the number of given experimental values should be equal to the number of parameters of the approximation function	No	0,73	0,58
Interpolation formulas of Lagrange and Newton define different interpolation polynomials	No	0,64	0,67
Spline uses global interpolation	No	0,64	0,59
In the case of approximation by the least squares method, the more values are given, the better the approximating function describes the experimental dependence	Yes	0,64	0,79
In the interpolation nodes, the values of the polynomial must coincide with the values of the function	Yes	0,55	0,92
The formulas of Lagrange and Newton give the same polynomial	Yes	0,36	0,86
The mechanical analog of spline is a flexible rod	Yes	0,36	0,86
Coincidence of the values of the source and the approximating functions at some points is not obligatory in the case of approximation of the function	Yes	0,27	0,73



**Fig. 4.** Percent of students with high, average and low depth of knowledge as a result of testing

Based on many years of experience in the implementation of learning research using a professional computer-based environments, pedagogical conditions of the effectiveness of such method of teaching are formulated: student's formation of the necessary knowledge and skills at the reproductive level; the formation of basic research skills; possession of modern ICT tools for research in a particular subject area; presence of motivation, emotional and volitional attitude to such activity; existence of a multilevel, individualized system of management of students' independent work.

## 8 Conclusions

Method of learning research is used in special laboratory practice with DSS (dynamic support synopsis – some models of numerical methods) for studying numerical methods of polynomial interpolation and numerical integration.

Pedagogical observations show that suggested methods work towards forming students' motivation and research competency. Students' completeness and depth of knowledge are on enough level according to results of testing and observations during the practical work.

Positive influence of suggested methods on educational results is possible only with developed methodology of investigations, appropriate didactic materials, individualized management of students' independent work and enough level of students' readiness to research activity: satisfactory knowledge and skills at the reproductive level; presence of basic research skills; ability to use modern ICT tools for research in a particular subject area; presence of motivation, emotional and volitional attitude to research activity.

We see prospects for further work in designing the methods of detailed diagnostic of the readiness of the student to learning research and approbation of new methods of individualized management of students' independent work.

## References

1. Bilousova, L. (ed.): Numerical Methods Courseware Based on Mathcad. Guidebook for Students. A publishing house FOP Virovec A.P. in the Publishing group "Apostrophe", Kharkiv (2011)
2. Humming, R.: Numerical Methods for Scientists and Engineers. 2nd edn. Dover Publications, Inc., New York (1999)
3. Demidovych, B., Maron, Y.: Foundations of Computational Mathematics. Nauka, Moscow (1966)
4. Zhaldak, M., Ramskyi, Yu.: Numerical Methods in Mathematics. Radianska shkola, Kyiv (1984)
5. Kalitkin, N.: Numerical Methods. Nauka, Moscow (1978)
6. Forsythe, G., Malcolm, M., Moler, C.: Computer Methods for Mathematical Computations. Prentice Hall, Englewood Cliffs (1977)
7. Teplytskyi, I.: Elements of Computer Modeling. Kryvyi Rih State Pedagogical University, Kryvyi Rih (2009)
8. Eich-Soellner, E., Führer, C.: Numerical Methods in Multibody Dynamics, Vieweg+Teubner Verlag, Wiesbaden (1998)
9. Chapra, S., Canale, R.: Numerical Methods for Engineers. McGraw Hill Education, New York (2015)
10. El-Gebeily, M., Yushau, B.: Numerical methods with MS Excel. The Mathematics Enthusiast. **4**(1), 84–92, article 6. <https://scholarworks.umt.edu/tme/vol4/iss1/6> (2007). Accessed 21 Mar 2019
11. Kazachkov, I.V., Fransson, T.H., Salomon, M., Kalion, V.A.: Interactive teaching and learning platform for numerical methods in energy. In: 41st Aerospace Sciences Meeting and Exhibit, Reno, Nevada, 6-9 January 2003. doi:10.2514/6.2003-943

12. Martín-Caraballo, A., Tenorio-Villalón Á.: Teaching numerical methods for non-linear equations with GeoGebra-based activities. *Int. Elect. J. Math. Ed.* **10**(2), 53–65. <https://www.iejme.com/article/teaching-numerical-methods-for-non-linear-equations-with-geogebra-based-activities> (2015). Accessed 21 Mar 2019
13. Kogatina, L.: Pedagogical conditions of efficiency of students' independent work at doing educational research. *Scientific Issues of Ternopil Volodymyr Hnatiuk National Pedagogical University. Series: Pedagogy.* **2015**(2), 131–136 (2015)
14. Ponomaryova, L.: Learning research as a factor of increasing of education quality. In: Yevdokymov V., Mykytiuk O. (eds.) *Tools of educational and science-research work*, vol. 13, pp. 28–34. H. S. Skovoroda Kharkiv State Pedagogical University, Kharkiv (2000)

# Methodology of Using Structural Equation Modeling in Educational Research

Liubov Panchenko<sup>[0000-0002-9979-0625]</sup>

National Technical University of Ukraine “Igor Sikorsky Kyiv Polytechnic Institute”,  
37, Peremohy Ave., Kyiv, 03056, Ukraine  
lubov.felixovna@gmail.com

**Abstract.** The article deals with the problem of using structural equation modelling (SEM) methodology in educational research. It allows the researcher to build multidimensional models of the phenomena and processes that are being studied. The SEM methodology is based on many well-known methods such as correlation, regression, factor analysis, variance analysis and covariance analysis. The methodology is mainly based on deductive logic, involves the preliminary construction of a structural model of relationships between variables in order to further check for consistency with the experimental data. The article provides an example of using the SEM methodology in educational research for PhD student. An important point in preparing specialists for using SEM is to select or obtain the necessary data sets that are representative and valid. During the research the Ukrainian teacher’s self-efficacy model with SEM methodology was checked, and the obtained results were compared with the research data of the worldwide teacher’s survey – The Teaching and Learning International Survey (TALIS). The lower self-efficacy of Ukrainian teachers, especially in the student engagement block, was showed.

**Keywords:** structure equation modelling, TALIS methodology, Ukrainian teachers, teacher’s self-efficacy, PhD student, AMOS, R.

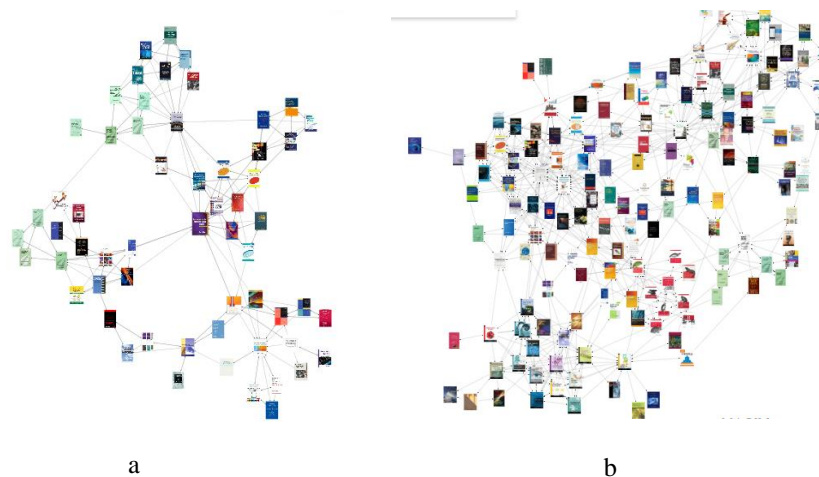
## 1 Introduction

### 1.1 Setting of a problem

In recent years, many PhD programs were organized in Ukraine. Qualitative scientific research is impossible without a systematic description of the studied phenomena; multidimensionality of the investigated phenomena requires the use of multidimensional analysis methods that are capable to identify causal relationships, latent factors, etc. A promising area in the field of multidimensional applied analysis is the structural modeling or structural equation modeling, which is becoming an increasingly popular tool for researchers in the field of education, psychology and social sciences [1-5].

Consequently, we consider it very important to train future doctors of philosophy to use it in the educational research.

The popularity of the SEM methodology is evidenced by the experiment we conducted. At the request of “structural equation modeling” to search books on Amazon.com (as of March 16, 2013), we obtained 59 items, the graph of which is clearly shown in fig.1a. In the center of the graph (Fig. 1a), where 5 subgraphs can be observed, there is the third edition of the bestseller, Principles and Practice of Modeling by Structural Equations (Rex B. Kline, Principles and Practice of Structural Equation Modeling) [1]. The companion site of this publication provides methodological support and offers download syntax, data and source files for all sample books for execution in three environments EQS, LISREL and Mplus, and a comparison of simulation results. A similar experiment, conducted on March 28, 2019, (Fig. 1b), shows interest growth in structural modeling; we have 157 items. Interestingly, the fourth edition of the same bestseller has the biggest rating there.



**Fig. 1.** a. Books on «structural equation modeling», Amazon.com (a – 2013. b – 2019)

While solving the scientific problem of training teachers to use the SEM methodology, the following main results were obtained in past author works: the content of the simulation training by the structural equations of specialists in the field of education is revealed; the dynamics of software simulation by structural equations is analyzed; the necessity of including these means in the courses for students and graduates of higher educational institutions of Ukraine that specialize in the field of education and social sciences is substantiated [6]. The syllabuses of PhD SEM courses of leading universities are analyzed (Higher School of Economics, St. Petersburg; University of Amsterdam; University of Vaasa, Finland; University of Mannheim; Iowa State University; Brown University; University of Leuven; School of Education University of Pittsburgh; Oslo University etc). The objectives of the SEM courses are defined as follows: using structural equation modeling methodology to study the problems of social and behavioral science, understanding the strengths and flaws of the method and its limitations, teaching methods of assessment, identification models, testing their validity, interpretation, critical evaluation of scientific publications on this subject,

using statistical software to perform structural equation modeling analysis, preparation of research reports in accordance with the standards of research [7].

In preparing specialists for using SEM an important point is to select or obtain the necessary data sets that are representative and valid. We offer our students the survey data from Ukrainian teachers [8-10].

On August 31, 2017, the Ukrainian Association of Educational Researchers completed the All-Ukrainian monitoring “Teaching and Learning Survey on Principals and Teachers of Secondary Education Institutions” (based on the TALIS methodology [11]). The study was conducted within the framework of the project “Teacher” and “Education Reform: Quality Assessment in an International Context”, which is implemented by the All-Ukrainian Foundation “Step by Step” with the support of the Ministry of Education and Science of Ukraine [8]. The study was attended by 3,600 teachers and 201 school principals from 201 schools, representing all regions of Ukraine. The results of the study, according to the OECD policy, are open and accessible.

The aim of the article, based on the survey data of Ukrainian teachers, is to check the model of teacher’s self-efficacy with SEM methodology, and to compare obtained results with the research data of the worldwide teacher’s survey – TALIS (2013).

## **1.2 Analysis of recent research and publications**

The methodology of structural modeling has received wide recognition in the global community. The study of the basics of structural modeling has become a component of the training of researchers specializing in social sciences [7]. In Russia, the ideas of structural modeling in relation to psychology are reflected in the works of O. Mitina [3] and A. Nasledov [4]. The use of SEM with an emphasis on economic research has been studied by Ukrainian scholar A. Chorny [5]. Unfortunately, in Ukraine, structural modeling is not sufficiently used in educational and social studies in general, and in the training of researchers at universities, in particular.

The aspects of the application of the SEM methodology to educational data (TALIS, 2013) are devoted to the following research. A structural equation model of determinants of the perceived impact of teachers’ professional development (the Abu Dhabi application) is reviewed in [12]. How school context and teacher’s characteristics predict distributed leadership is presented in [13]. The invariance of teachers’ sense of self-efficacy measured across countries is reviewed by R. Scherer and others [14].

## **2 Results of the study**

TALIS (Teaching and Learning International Survey) is one of the most prestigious international comparative education projects. The project is dedicated to studying the environment and work conditions of school teachers. It has been implemented since 2008 by a research consortium under the Organization for Economic Cooperation and Development (OECD). 24 OECF countries and partner countries participated in the

first wave of TALIS study in 2008, 34 – in the second wave in 2013, and 44 countries plan to participate in 2018 [8; 11].

All-Ukrainian monitoring survey of teaching and learning among school principals and teachers of general educational institutions (according to the methodology All-Ukrainian research on TALIS methodology) is an example of use of international instruments for studying national educational space and identifying the place of the Ukrainian teacher community in the international community educational context. The purpose of the research is to identify and analyze socio-demographic and professional characteristics of Ukrainian teachers and academic staff and the environment of schools on the basis of reliable comparable metrics [8].

3600 teachers of 5-9 grades of secondary schools (level ISCED 2) and 201 school principals from 201 schools participated in the survey in 2017. Error of simple random sampling is 1.6%, the school sample selection error takes into account design effect is 2.3%.

From the Ukrainian teacher's survey file [9] we selected 3477 lines without missing values for 12 variables that represented the teacher's self-efficacy (Table 1).

**Table 1.** Variables of teacher's self-efficacy

Variable name	Content
TT2G34A	Get students to believe they can do well in school work
TT2G34B	Help my students value learning
TT2G34C	Craft good questions for my students
TT2G34D	Control disruptive behavior in the classroom
TT2G34E	Motivate students who show low interest in school work
TT2G34F	Make my expectations about student behavior clear
TT2G34G	Help students think critically
TT2G34H	Use a variety of assessment strategies
TT2G34I	Provide an alternative explanation, for example, when students are confused
TT2G34J	Implement alternative instructional strategies in my classroom
TT2G34K	Get students to follow classroom rules
TT2G34L	Calm down a student who is disruptive or noisy

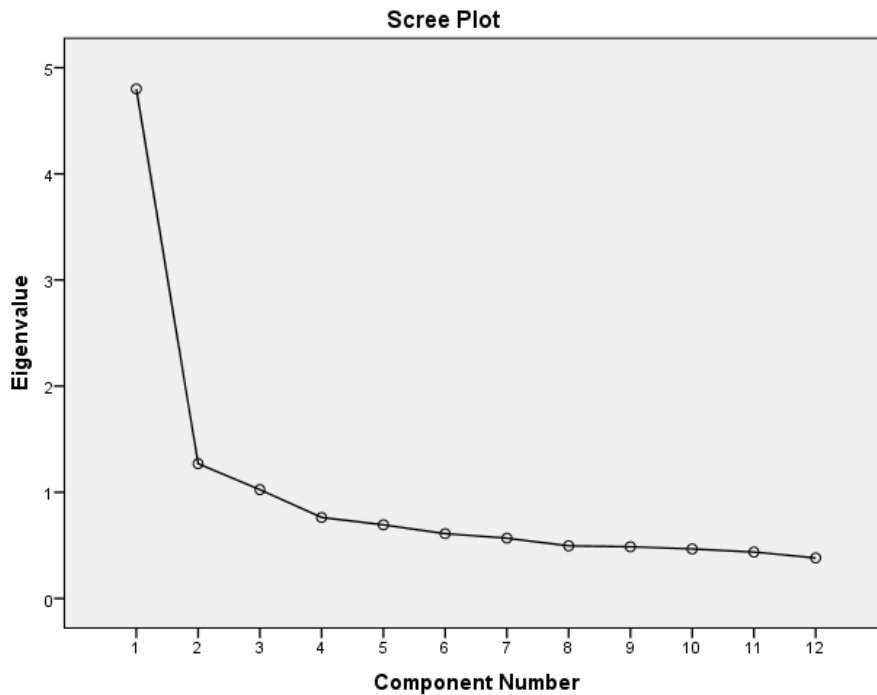
A. Bandura defines self-efficacy as a personal judgment of “how well one can execute courses of action required to deal with prospective situations” [15]. He names four sources of efficacy beliefs: 1) mastery experiences; 2) vicarious experiences; 3) verbal persuasion; 4) emotional and physiological states.

Professional teacher's self-efficacy, in general, is the perception of a person's own ability to mobilize motivation, cognitive resources and behavioral activity that are needed to control the situation in order to achieve the intended purpose [15-17].

TALIS model for teacher consists of three components of self-efficacy: self-efficacy in classroom management; self-efficacy in instruction; self-efficacy in student engagement.

We will conduct a factor analysis for these data. The obtained values of Kaiser-Meyer-Olkin (0.902) and Bartlett's Test of Sphericity (13308,  $p < 0.001$ ) indicate that

factor analysis is a suitable method for these data. The scree plot below shows three factors.



**Fig. 2.** Scree plot: a line plot of the eigenvalues of factors

Let us consider the rotated component matrix (Table 2). It demonstrates that the first factor, loading high factor weight of the attributes, is related to the class management, the second one is related to the student's engagement, and the third one to the instruction.

You can also observe that the variable "Craft good questions for my students" is more related to the factor "Student engagement" than the factor "Instruction". As you see, three factors explain 59.1 % of variability (Table 3).

Scientists identify next five steps in SEM application [1; 4].

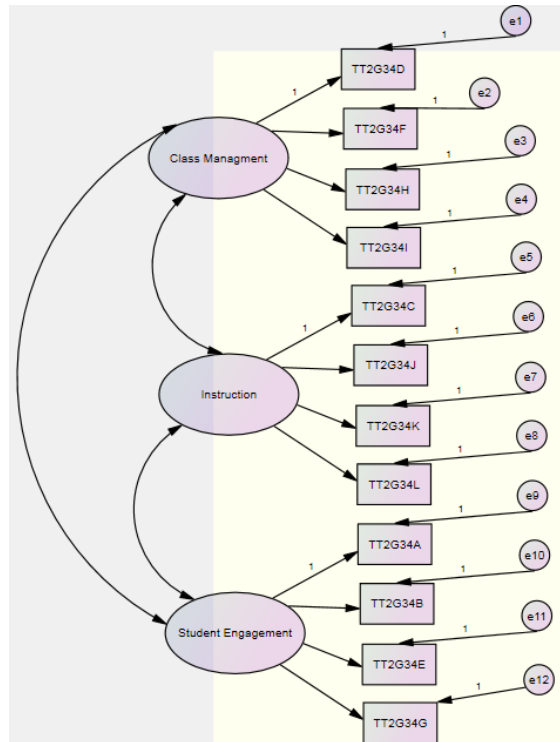
1. model formation. The model depicts the graphical views of the researcher about the structure of the variable and latent constructs of ties. At the same time, they decide which parameters should be fixed, and which should be left free.
2. model identification
3. model evaluation
4. checking the consistency of the model
5. model correction by adding new links and eliminating insignificant links.

Let us build a model of confirmatory factor analysis with AMOS SPSS (Fig. 3).



**Table 2.** Rotated Component Matrix

	Factor 1: Class management	Factor 2: Student Engagement	Factor 3: Instruction
Control disruptive behavior in the classroom	.795		
Calm a student who is disruptive or noisy	.773		
Get students to follow classroom rules	.765		
Make my expectations about student behavior clear	.596		
Help my students value learning		.816	
Get students to believe they can do well in school work		.764	
Motivate students who show low interest in school work		.644	
Help students think critically		.448	
Craft good questions for my students		.443	
Provide an alternative explanation, for example, when students are confused			.785
Implement alternative instructional strategies in my classroom			.736
Use a variety of assessment strategies			.730



**Fig. 3.** Initial teacher's self-efficacy model in AMOS SPSS

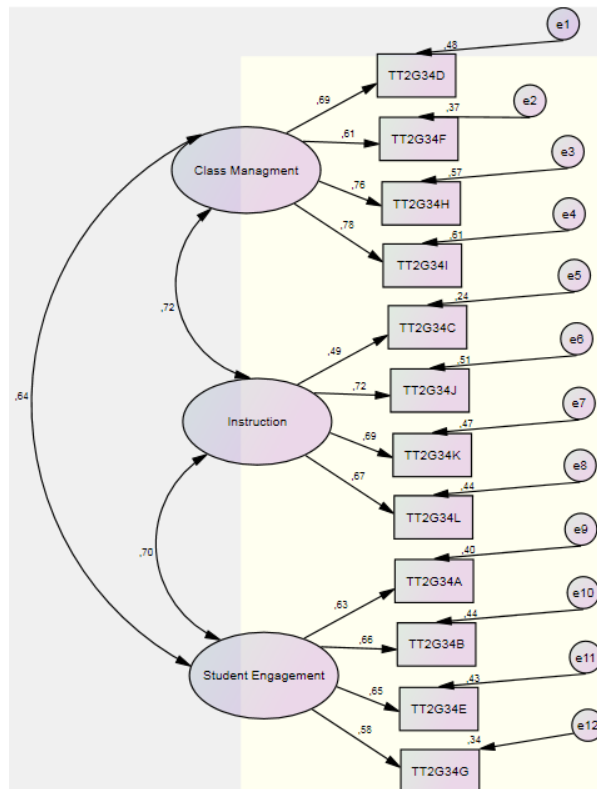
**Table 3.** Total Variance Explained

Component	Rotation Sums of Squared Loadings		
	Total	% of Variance	Cumulative %
1	2.571	21.425	21.425
2	2.313	19.274	40.698
3	2.211	18.429	59.127

We got the following results. Number of distinct sample moments: 78; number of distinct parameters to be estimated: 27; degrees of freedom: 78–27=51. Criteria for coherence RMSEA 0.07 < 0.08, that is, the model is consistent with the data.

Using the data [8], we clearly compared the indicators of self-efficacy of teachers in Ukraine and in the world (Table 4, Fig. 5). The graph shows that self-efficacy of Ukrainian teachers is lower, especially in the student engagement block (variable “Get students to believe they can do well in school work” – difference was 26.4 %, “Help my students value learning” – 26%, “Motivate students who show low interest in school work” – 19.4 %).

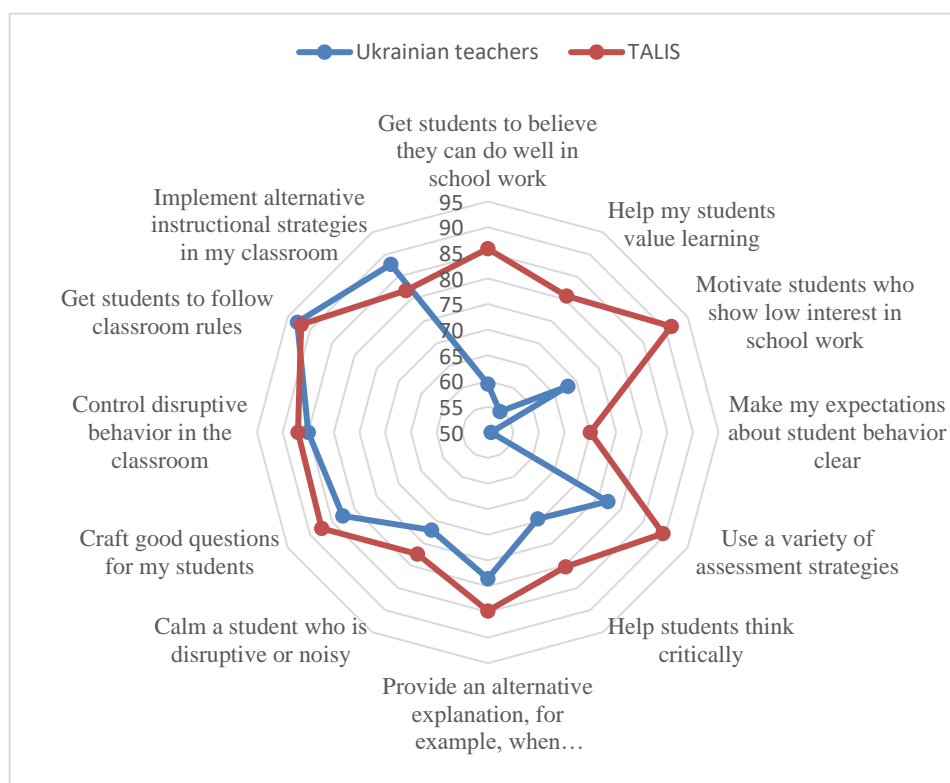
You can see the resulting teacher’s self-efficacy model in the Figure 4.



**Fig. 4.** Resulting teacher’s self-efficacy model in AMOS SPSS

**Table 4.** Indicators of self-efficacy of teachers in Ukraine and in the world (%)

Variables	Ukrainian teachers	TALIS	Difference
A. Get students to believe they can do well in school work	59.4	85.8	26.4
B. Help my students value learning	54.7	80.7	26
C. Craft good questions for my students	82.6	87.4	4.8
D. Control disruptive behavior in the classroom	85	87	2
E. Motivate students who show low interest in school work	50.6	70	19.4
F. Make my expectations about student behavior clear	68	91.3	23.3
G. Help students think critically	69.5	80.3	10.8
H. Use a variety of assessment strategies	77	89.4	12.4
I. Provide an alternative explanation, for example, when students are confused	78.5	84.8	6.3
J. Implement alternative instructional strategies in my classroom	87.8	81.9	-5.9
K. Get students to follow classroom rules	92.9	92	-0.9
L. Calm a student who is disruptive or noisy	72	77.4	5.4



**Fig. 5.** Comparison of teachers' self-efficacy in Ukraine and in the world

### 3 Conclusions and perspectives of further research

Measurements that are used in modern educational research are becoming more and more complex. SEM methodology helps researcher determine the effectiveness of educational innovations in different educational contexts, as well as model and study phenomena in their interrelations; understand the influence of latent factors, develop systemic and critical thinking.

An important point in training specialists to use SEM is to select or obtain the necessary data sets that are representative and valid. For example, we offer our students such data: All-Ukrainian survey data from Ukrainian teachers. The main criteria for choosing it are: 1) an array of data is freely accessible, 2) it is large (contains 3600 lines), 3) it is accompanied by supporting documentation, 4) the array and documents have Ukrainian and English versions, 5) the array variables are simple and understandable, 6) it is possible to conduct comparative studies with the data of the International Talis Teacher's Survey.

During the research the teacher's self-efficacy model using SEM methodology were checked, the obtained results were compared with the TALIS survey data (2013). The research demonstrated that self-efficacy of Ukrainian teachers, especially in the student engagement block, was lower.

Further development of work in this direction is the creation of teaching and methodological support for modeling by structural equations in the form of a computer workshop in the AMOS and R environments for the training of researchers in the field of pedagogy and social sciences.

### References

1. Kline, R.: Principles and Practice of Structural Equation Modeling. The Guilford Press, New York (2010)
2. Teo, T., Khine, M.S. (ed): Structural Equation Modeling in Educational Research. Sense Publishers, Rotterdam/Boston/Taipei (2009)
3. Mitina, O.V.: Modelirovanie latentnykh izmeneniy s pomoschyu strukturnykh uravneniy (Modeling latent changes using structural equations). Eksperimentalnaya psihologiya. 1, 131–148 (2008).
4. Nasledov, A.D.: IBM SPSS Statistics 20 i AMOS: professionalnyy statisticheskiy analiz dannykh (IBM SPSS Statistics 20 and AMOS: Professional Statistical Data Analysis). Piter, SPb (2013)
5. Chornyi, A.: Modeliuvannia latentnykh zminnykh: rozvytok, suchasnyi stan ta perspektyvy (Modeling latent variables: development, current state and prospects). Visnyk Kyivskoho nats. un-tu imeni Tarasa Shevchenka. Ser. Ekonomika. 129, 41–43 (2011)
6. Panchenko, L.F.: Modeliuvannia strukturnymy rivnianniamy yak instrument pedahohichnoho doslidzhennia (Modeling by structural equations as a tool for pedagogical research). Visn. Luhan. nats. un-tu imeni Tarasa Shevchenka: Pedahohichni nauky. **18**(277), 108–114 (2013)
7. Panchenko, L.F., Razoronova, M.V.: Modeliuvannia strukturnymy rivnianniamy yak skladnyk pidhotovky doktoriv filosofii (Modeling by structural equations as a component of

- preparation of doctors of philosophy) *Naukovyi visnyk Donbasu*. 1–2. [http://nvd.luguniv.edu.ua/archiv/2016/N1-2\(33-34\)/5.PDF](http://nvd.luguniv.edu.ua/archiv/2016/N1-2(33-34)/5.PDF) (2016). Accessed 20 Mar 2019
8. Shchudlo, S., Zabolotna, O., Lisova, T.: *Ukrainian Teachers and the Learning Environment. Results of All-Ukrainian Monitoring Survey of Secondary School Teachers and Principals (by the TALIS methodology)*. Trek LTD, Drohobych (2018)
  9. Access the full survey by TALIS methodology raw data (in SPSS): TEACHERS\_DATA: [https://drive.google.com/open?id=1bzh6U7MnOaFSt\\_1CV1BsQndCuLX\\_WpWt](https://drive.google.com/open?id=1bzh6U7MnOaFSt_1CV1BsQndCuLX_WpWt). Accessed 20 Feb 2019
  10. Questionnaires (in ukr): TEACHERS\_Questionnaire: <https://drive.google.com/open?id=1L6SHvqpMAGPzeLkp8Ksb9E-KXdnkd0sd> . Accessed 20 Feb 2019
  11. TALIS – OECD Teaching and Learning International Survey – OECD. <http://www.oecd.org/education/talis> (2019). Accessed 20 Feb 2019
  12. Badri, M., Alnuaimi, A., Yang, G., Rashidi, A., Sumaiti, R.: Structural Equation Model of Determinants of the Perceived Impact of Teachers’ Professional Development – The Abu Dhabi Application. *SAGE Open*. **7**(2) (2017). doi:10.1177/2158244017702198
  13. Liu, Y., Bellibas, M.R., Printy, S.: How school context and educator characteristics predict distributed leadership: A hierarchical structural equation model with 2013 TALIS data. *Educational Management Administration & Leadership*. **46**(3), 401–423 (2018). doi:10.1177/1741143216665839
  14. Scherer, R., Jansen, M., Nilsen, T., Areepattamannil, S., Marsh, H.W.: The Quest for Comparability: Studying the Invariance of the Teachers’ Sense of Self-Efficacy (TSES) Measure across Countries. *PLOS ONE*. **11**(3) (2016). doi:10.1371/journal.pone.0150829
  15. Bandura, A.: Self-efficacy mechanism in human agency. *American Psychologist*. **37**(2), 122–147 (1982). doi:10.1037/0003-066X.37.2.122
  16. Kremeshna, T.I.: *Pedahohichna samoefektyvnist: shliakh do uspishnoho vykladannia (Pedagogical Self-Efficiency: The Way to Successful Teaching)*. Uman (2010)
  17. Krasnoryadtseva, O.M., Kabrin, V.I., Muraveva, O.I., Podoyntsina, M.A., Chuchalova, O.N.: *Psihologicheskie praktiki diagnostiki i razvitiya samoeffektivnosti studencheskoy molodezhi (Psychological practices of diagnostics and development of self-efficacy of student youth)*. Izdatelskiy Dom TGU, Tomsk (2014)

# Modeling of Cognitive Process Using Complexity Theory Methods

Vladimir Soloviev<sup>[0000-0002-4945-202X]</sup>, Natalia Moiseienko<sup>[0000-0002-3559-6081]</sup> and  
Olena Tarasova<sup>[0000-0002-6001-5672]</sup>

Kryvyi Rih State Pedagogical University, 54 Gagarin Ave., Kryvyi Rih, 50086, Ukraine  
{vnsoloviev2016, n.v.moiseenko, e.ju.tarasova}@gmail.com

**Abstract.** The features of modeling of the cognitive component of social and humanitarian systems have been considered. An example of using multiscale, multifractal and network complexity measures has shown that these and other synergetic models and methods allow us to correctly describe the quantitative differences of cognitive systems. The cognitive process is proposed to be regarded as a separate implementation of an individual cognitive trajectory, which can be represented as a time series and to investigate its static and dynamic features by the methods of complexity theory. Prognostic possibilities of the complex systems theory will allow to correct the corresponding pedagogical technologies.

**Keywords:** cognitive systems, complex systems, complex networks, synergetics, degree of complexity, new pedagogical technologies.

## 1 Introduction

Recently, it has become clear that pedagogical science operates on the transmission of a kind of structured information that is knowledge. Information, as the main concept of cybernetics, is characterized by a metric function and, thus, the search for optimal management of educational processes is translated into a plane of mathematical modeling [1-3].

In science, starting with R. Descartes, I. Newton and P.-S. Laplace determinism and strict conditional constructions had been predominant for a long time. Initially, these views were developed in science and mathematics, and then moved into the humanitarian field, in particular, in pedagogy. As a result, many attempts have been made to organize education as a perfectly functioning machine. According to the dominant ideas then, for the education of a person the only need was to learn how to manage such a “machine”, that is to turn education into a kind of production and technological process. The emphasis was on standardized training procedures and fixed patterns of learning. Thus appeared the beginning of the technological approach in teaching and, consequently, the predominance of teaching the reproductive activity of students.

For many complex systems, the phenomenon of self-organization is characteristic [4]. It leads to the fact that very often a few variables, the so-called order parameters, are detected very often for the description of an object, which is described by a large or even infinite number of variables [5]. These parameters “subordinate” other variables, defining their values. The researchers are aware of the mechanisms of self-organization, which lead to the allocation of parameters of order, methods of their description as well as the corresponding mathematical models. However, it is likely, our brain has a brilliant ability to find these parameters, to “simplify reality”, finding more effective algorithms for their selection. The process of learning and education allows one to find successful combinations that can be the order parameter in certain situations or the mechanisms of searching for such parameters (“learn to study”, “learn to solve non-standard tasks”).

It is also advisable to use the ideas of a soft (or fuzzy) simulation. All said by V.I. Arnold, in the case of hard and soft models [6], takes place in pedagogical science. Since in humanitarian systems the results of their interaction and development can not be predicted in detail, by analogy with complex quantum systems one can speak the principle of uncertainty for humanitarian systems. In the process of learning unplanned small changes always occur as well as fluctuations in the various pedagogical systems (and the individual, and the team of students, and knowledge systems). Therefore, the basis of modern educational models should lie in the principle of uncertainty in a number of managerial and educational parameters.

Network education refers to a new educational paradigm [7], which is called “networking”. Its distinctive features are learning based on the synthesis of the objective world and virtual reality by activating both the sphere of rational consciousness and the sphere of intuitive, unconscious. The networking of a student and a computer is characterized as an intellectual partnership representing the so-called “distributed intelligence”. Unlike the traditional, network education strategy is focused not on the systematization of knowledge and the assimilation of the next main core of information, but on the development of abilities and motivation to generate their own ideas [8].

Within the framework of recent research in the Davos forum, 10 skills were identified, most demanded by 2022 [9]: (1) Analytical thinking and innovation; (2) Active learning and learning strategies; (3) Creativity, originality and initiative; (4) Technology design and programming; (5) Critical thinking and analysis; (6) Complex problem-solving; (7) Leadership and social influence; (8) Emotional intelligence; (9) Reasoning, problem-solving and ideation; (10) Systems analysis and evaluation. Obviously, the cognitive component in the transformation processes of Industry 4.0 is dominant, which actualizes attention to the study of cognitive processes.

The complexities here are reduced to the fact that cognitive processes are poorly formalized. Therefore, the field of theoretical works until recently was virtually empty. The picture has fundamentally changed with the use of recent synergetic studies. The fact is that the doctrine of the unity of the scientific method asserts: for the study of events in the social-humanitarian systems, the same methods and criteria apply to the study of natural phenomena. Significant success was achieved within the

framework of interdisciplinary approaches and the theory of self-organization – synergetics [4, 5].

The process of intellection is a cognitive process characterized by an individual cognitive trajectory whose complexity is an integro-differential characteristic of an individual. The task is to quantify cognitive trajectories and present them in the form of a time series that can be analyzed quantitatively. The theory of complexity introducing various measures of complexity, allows us to classify cognitive trajectories by complexity and choose more complex, as more efficient ones. The analysis procedure can be done dynamically, by correcting the trajectories by means of progressive pedagogical technologies.

Previously, we introduced various quantitative measures of complexity for particular time series, in particular: algorithmic, fractal, chaos-dynamic, recurrent, nonreversible, network, and others [10]. Significant advantage of the introduced measures is their dynamism, that is, the ability to monitor the time of change in the chosen measure and compare with the corresponding dynamics of the output time series. This allowed us to compare the changes in the dynamics of the system, which is described by the time series, with characteristic changes in concrete measures of complexity and draw conclusions about the properties of the cognitive trajectory.

Objects of research are cognitive processes that control neurophysiological and other cognitive characteristics of a person:

- the length of the full step of different age children [11], a healthy young person and the elderly, or those with neurodegeneration (Alzheimer's, Parkinson's, Huntington's, etc. [12]);
- human recalls of words [13];
- objects of cognitive linguistics – the works of various authors, different genres, written in different languages [14];
- discretized multi-genre musical compositions [15].

The corresponding databases in the form of time series are in open access [16].

In this paper, we consider some of the informative measures of complexity and adapt them in order to study the cognitive processes. The paper is structured as follows. Section 2 describes previous studies in these fields. Section 3 presents information mono- and multiscale measures of complexity. Section 4 describes the technique of fractal and multifractal. Network measures of complexity and their effectiveness in the study of cognitive processes are presented in Section 5.

## **2 Analysis of previous studies**

Researchers interested in human cognitive processes have long used computer simulations to try to identify the principles of cognition [17]. Existing theoretical developments in this scientific field describe complex, dynamic, and emergent processes that shape intra- (e.g., cognition, motivation and emotion) and inter- (e.g., teacher-student, student-student, parent-child interactions, collaborative teams) person phenomena at multiple levels. These processes are fundamental characteristics of



complex systems but the research methods that are used sometimes do not match the complexity of processes that need to be described.

From the set of methods of the theory of complex systems we consider only those related to information, fractal, and network complexity measures.

Entropic measures in general are relevant for a wide variety of linguistic and computational subfields. In the context of quantitative linguistics, entropic measures are used to understand laws in natural languages, such as the relationship between word frequency, predictability and the length of words, or the trade-off between word structure and sentence structure [18]. Together with Shannon's entropy, more complex versions are used: the Approximate entropy, Sample entropy [19].

In order to demonstrate the scale-invariant properties of cognitive processes, these types of entropy were used in a multiscale version in the study of cognitive processes of cerebral activity [20], human locomotion functions [21], in linguistics [19].

Cognitive processes like most complex systems [22] exhibit fractal properties [23, 24], analysis and the use of results requires careful research.

In recent years, the complex networks methods [25] have become widespread. They not only allow the construction and exploration of networks with obvious (as in linguistics) nodes and links [26], but also those reproduced from the time series by actively developing methods [27, 28].

In our recent works, we have used some of the modern methods of the theory of complex systems for the analysis of such a complex system as cryptocurrency [29, 30]. In this paper, we adapt them to cognitive signals.

### **3 Information mono- and multiscale measures of complexity**

Based on the different nature of the methods laid down in the basis of the formation of the measure of complexity, they pay particular demands to the time series that serve the input. For example, information requires stationarity of input data. At the same time they have different sensitivity to such characteristics as determinism, stochasticity, causality and correlation. In this paper, we do not use classical information measures (for example, the complexity behind Kolmogorov, entropy measures), since complex signals manifest complexity inherent to them on various spatial and temporal scales, that is, they have scale-invariant properties. They, in particular, are manifested through the power laws of distribution.

Obviously, the classic indicators of algorithmic complexity are unacceptable and lead to erroneous conclusions. To overcome such difficulties, multiscale methods are used.

The idea of this group of methods includes two consecutive procedures: 1) coarse graining ("granulation") of the initial time series – the averaging of data on non-intersecting segments, the size of which (the window of averaging) increased by one when switching to the next largest scale; 2) computing at each of the scales a definite (still mono scale) complexity indicator.

The process of “rough splitting” consists in the averaging of series sequences in a series of non-intersecting windows, and the size of which – increases in the transition from scale to scale [31].

Each element of the “granular” time series is in accordance with the expression:

$$y_j^\tau = 1/\tau \sum_{i=(j-1)\tau+1}^{j\tau} x_i, \quad 1 \leq j \leq N/\tau, \quad (1)$$

where  $\tau$  characterizes the scale factor. The length of each “granular” row depends on the size of the window and is even  $N/\tau$ . For a scale equal to 1, the “granular” series is exactly identical to the original one.

We demonstrate the work of multi-scale measures of complexity on examples of Approximate Entropy and Sample Entropy [19]. Approximate Entropy (*ApEn*) is a “regularity statistic”, which determines the possibility of predicting fluctuations in time series. Intuitively, it means that the presence of repetitive patterns (sequences of a certain length constructed from successive numbers of sequences) fluctuations in the time series leads to a greater predictability of the time series than those in which there are no repetitions of the templates. The comparatively large value of *ApEn* shows the likelihood that similar observation patterns will not follow one another. In other words, a time series containing a large number of repetitive patterns has a relatively small *ApEn*, and the *ApEn* value for a less predictable (more complex) process is greater.

When calculating *ApEn* for a given time series  $S_N$  consisting of  $N$  values  $t(1), t(2), t(3), \dots, t(N)$  two parameters are chosen,  $m$  and  $r$ . The first of these parameters,  $m$ , indicates the length of the template, and the second –  $r$  – defines the similarity criterion. The sequences of time series elements  $S_N$  consisting of  $m$  numbers taken starting from the number  $i$  are called, and are called vectors  $p_m(i)$ . The two vectors (patterns),  $p_m(i)$  and  $p_m(j)$ , will be similar if all the difference pairs of their respective coordinates are less than the values of  $r$ , that is, if  $|t(i+k)-t(j+k)| < r, 0 \leq k \leq m$ .

For the considered set of all vectors  $p_m$  of the length  $m$  of the time series  $S_N$ , values:

$$C_{im}(r) = \frac{n_{im}(r)}{N - m + 1} \quad (2)$$

can be calculated. Where  $n_{im}(r)$  – the number of vectors in  $p_m$ , similar to the vector  $p_m(i)$  (taking into account the chosen similarity criterion  $r$ ). The value  $C_{im}(r)$  is the fraction of vectors of length  $m$ , which are similar to the vector of the same length, whose elements begin with the number  $i$ . For a given time series, the values  $C_{im}(r)$  for each vector in  $p_m$  are calculated, after which there is an average value  $C_m(r)$  that expresses the prevalence of similar vectors of length  $m$  in a row  $S_N$ . Directly the *ApEn* for the time series  $S_N$  using the vectors of length  $m$  and the similarity criterion  $r$  is determined by the formula:

$$ApEn(S_N, m, r) = \ln(C_m(r)/C_{m+1}(r)) \quad (3)$$

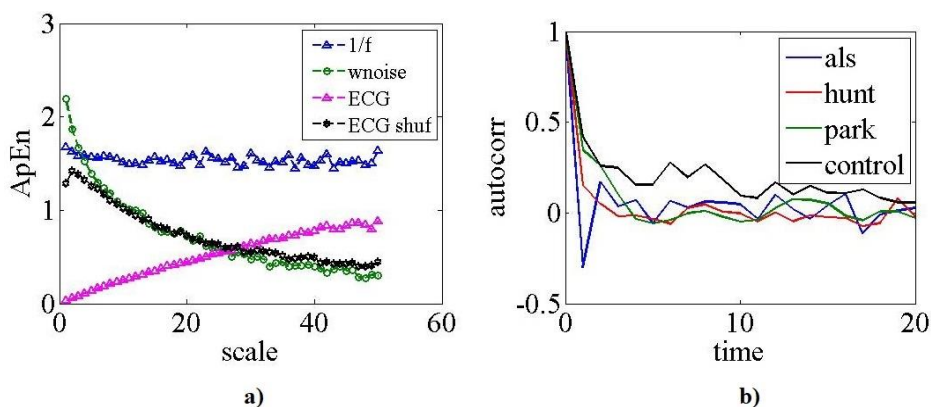
that is, as a natural logarithm of the ratio of the repetition of vectors of length  $m$  to the repetition of vectors in length  $m+1+1$ .

Thus, if there are similar vectors in the time series,  $ApEn$  will estimate the logarithmic probability that the subsequent intervals after each of the vectors will be different. The smaller  $ApEn$  values correspond to the greater likelihood that vectors follow similar ones. If the time series is very irregular, the presence of such vectors can not be predictable and the value of  $ApEn$  is relatively large.

Sample Entropy ( $SampEn$ ) is similar to the  $ApEn$ , but when calculating the  $SampEn$ , two conditions are added:

- does not take into account the similarity of the vector to itself;
- when calculating the probabilistic values of  $SampEn$ , the length of the vectors is not used.

In **Ошибка! Источник ссылки не найден.** a shows the  $ApEn$  dependence of the scale to the test signals – flicker ( $1/f$ ) white noise (wnoise) and electrocardiogram (ECG) signal compared to the shuffled signal (ECG shuffled).



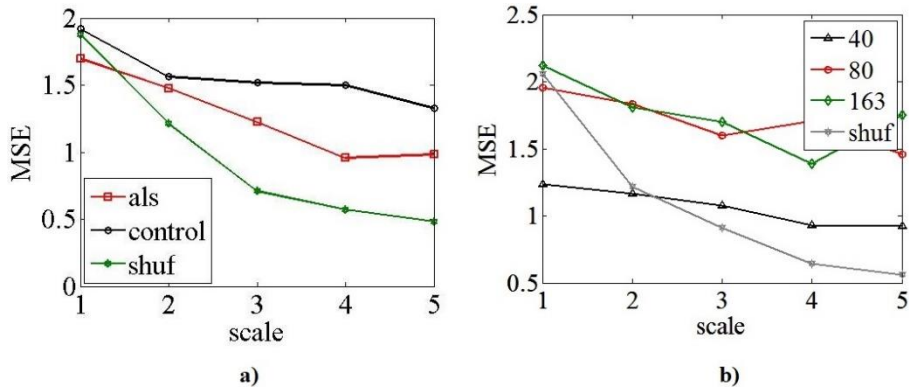
**Fig. 1.** (a)  $ApEn$  of artificial and natural signals, depending on the scale; (b) autocorrelation functions for control the stride intervals fluctuations and Alzheimer’s disease (als), Huntington’s (hunt) and Parkinson’s (park)

From Fig. 1a it is evident that, as expected, a flicker signal was a scale-invariant one. The ECG signal is complex on a large scale. Its complexity is lost when shuffled and becomes very close to a random signal.

Cognitive signals differ in the functions of autocorrelation: the more complex ones have a longer “memory”, which is manifested in the slowdown of the function of autocorrelation with the lag (Fig. 1b).

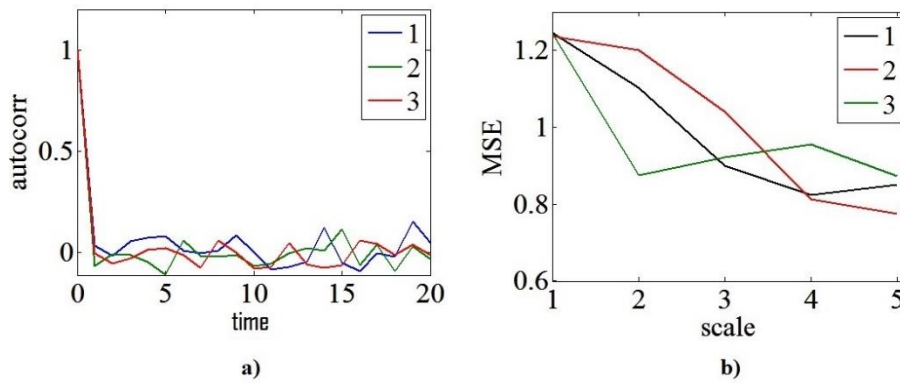
Accordingly, the signal of a healthy person and a multiscale entropy measure is more complicated (Fig. 2a). We also investigated multiscale complexity measures for time series of stride intervals in children from 40 to 163 months (Fig. 2b).

Obviously, the complexity of the signal for an older child is increasing.



**Fig. 2.** Multiscale entropy of stride intervals time series templates for healthy and Alzheimer’s disease (a) and children of all ages (b)

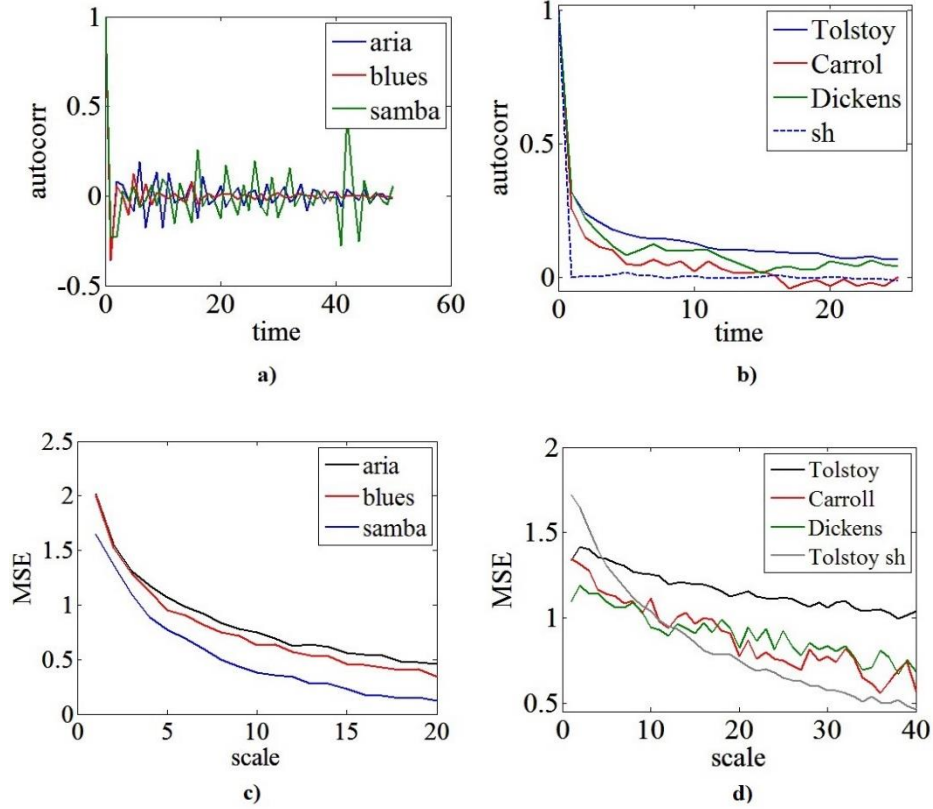
The next study cognitive signal is the time series of time intervals between human-to-word responses (human recalls of words). Recall in memory refers to the mental process of retrieval of information from the past and is a way to study the memory processes of humans and animals [13]. Recall describes the process in which a person is given a list of items to remember and then is tested by being asked to recall. For the autocorrelation function and the multiscale *SampEn* we obtain the results presented in Fig. 3.



**Fig. 3.** Autocorrelation functions (a) and MSE measures of complexity (b) signals 1-3 series of recalls

Unfortunately, due to insufficient statistics and short-term time series, identification of differences in these methods is not possible.

Similar studies for musical works of various genres (aria, blues, brazilian samba) and literary works by famous authors (L. Tolstoy’s “War and Peace”, L. Carroll “Alice in Wonderland”, C. Dickens “Cricket on the Hearth”) gave the results shown in Fig. 4.



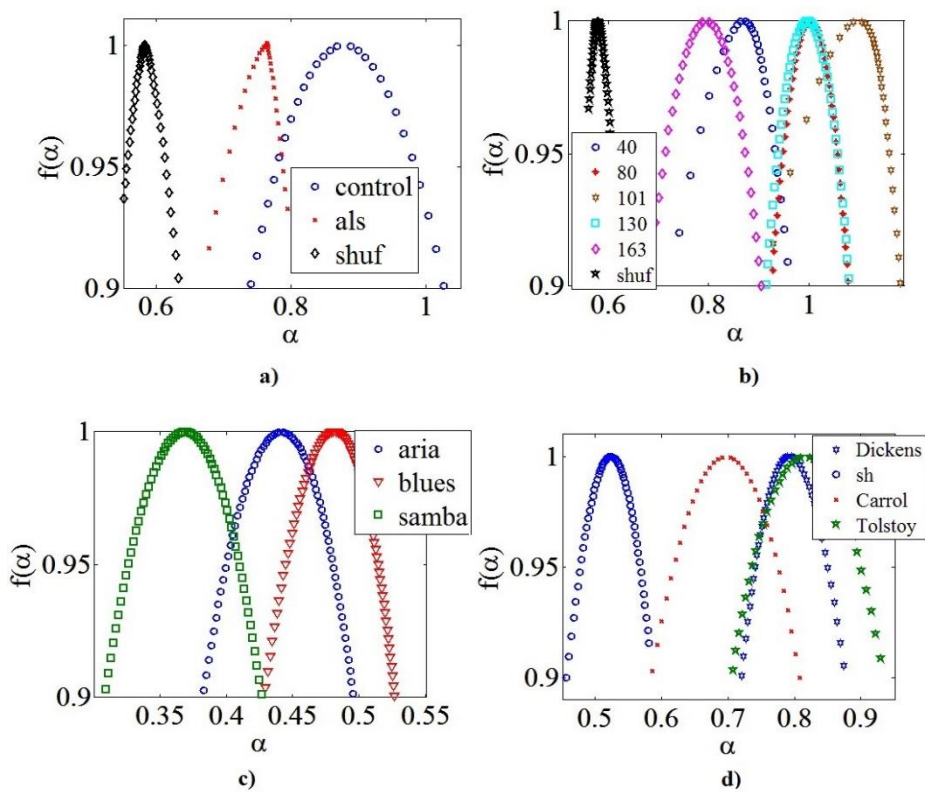
**Fig. 4.** Autocorrelation of musical (a) and literary (b) works; (c) and (d) are the corresponding multiscale entropy measures of complexity

Obviously, MSE allows classification of the analyzed cognitive signals in terms of complexity.

#### 4 Multifractal measures of complexity

In the general case, the procedure of popular Multifractal Detrended Fluctuation Analysis (MF-DFA) is implemented by the following algorithm. Let be a sequence of length  $N$ . Then determine the accumulation  $Y(i) \equiv \sum_{k=1}^i (x_k - \bar{x})$ ,  $i = \overline{1..N}$ . We divide it into  $N_s = \text{int}(N/s)$  segments of the same length  $s$  that do not overlap. For each of the  $N_s$  sequences, we calculate the local trend by the least squares method, determine the deviations  $F^2(v, s) = 1/s \sum_{k=1}^s (Y((v-1)s + i) - y_v(i))^2$  for each segment  $v$ ,  $v = \overline{1..N_s}$  and for each  $v = \overline{N_s + 1..2N_s}$ . There  $y_v(i)$  is an interpolating polynomial on the segment  $v$ . Find the mean for all subsequences to obtain the

function of  $q$ -order fluctuations  $F_q(s) = \left( \frac{1}{2N} \sum_{v=1}^{2N_s} (F^2(s, v))^{q/2} \right)^{1/q}$ . The standard DFA method corresponds to the case  $q=2$ . Determine the scaling behavior of the fluctuation function by analyzing the double logarithmic scale of the dependence  $F_q(s)$  on  $q$ . If the sequence  $x_i$  has long-term correlations,  $F_q(s)$  increases with increasing  $s$  according to the power law  $F_q(s) \cong s^{h(q)}$ . For stationary time series,  $h(2)$  identical to the Hurst exponent. Thus, the function  $h(q)$  can be called the generalized Hurst exponent.



**Fig. 5.** Spectra of multifractality (a) reaching the stage of healthy and sick patients; (b) children of all ages; (c) musical works of different genres; (d) literary works

Together with the generalized Hurst exponent, a spectrum of generalized fractal dimensions  $D_q$  is introduced that characterize the distribution of points in a given domain and is determined by the relation  $D_q = \tau(q)/(q-1)$ , where the function  $\tau(q)$  has the form  $\tau(q) = \lim_{s \rightarrow 0} [\ln z(q, s) / \ln s]$ , and  $Z(q, s)$  is a generalized statistical sum which is characterized by an index of degree  $q$ .

To characterize the multifractal set, the so-called multifractal spectrum function  $f(\alpha)$  (the spectrum of singularities of a multifractal) is used, which is actually equal to the Hausdorff dimension of a homogeneous fractal subset of the initial set, giving a dominant contribution to the statistical sum for a given  $q$  value. The connection between the values  $f(\alpha)$  and  $\tau(q)$  is determined by the relationship  $\tau(q) = q\alpha - f(\alpha)$ .

The extremum of the function  $f(\alpha)$  determines some average value of the Hurst exponent, and the value  $\Delta\alpha = \alpha_{\max} - \alpha_{\min}$  – the width of the spectrum of the multifractality – characterizes the degree of complexity of the system.

In Fig. 5 shows the spectra of multifractality of some of the cognitive systems described above.

We see that more complex signals have wider spectra of multifractality. Consequently, the multifractal measure of complexity can be used to analyze cognitive signals. We have implemented a dynamic procedure for calculating multifractal parameters, which allows you to follow the change in the complexity of the signal in time.

## **5 Complex network methods for studying cognitive processes**

One of the most important areas of cognitive science is cognitive linguistics. Cognitive linguistics is a trend in linguistics that studies and describes the language in terms of cognitive mechanisms that underlie human mental activity. Thus, cognitology is, so to speak, a computer that characterizes a person by analyzing his psyche, mental activity, and on the first place among the tasks put forward research language that is inextricably linked with human.

The significance of language for cognition is extremely great, because it is through language that one can objectivize the mental activity, that is, verbalize it. On the other hand, learning a language is an indirect way of studying cognition, because cognitive and language structures are in certain proportions. One of the tools of the study of cognitive linguistics is the theory of complex networks. The nodes in such networks are elements of these complex systems, and the links between nodes – the interaction between the elements.

In the last decade, the structural properties of language, the texts of literary works and texts related to religious consciousness, as well as the organization of musical works and painting began to be studied and analyzed from the point of view of the application of methods of the complex networks theory. Relevant networks form a special, little-known category, which is called cognitive networks [25].

The term “cognitive networks” was proposed in studies on the research of the network structure of the natural language. Of particular interest is the study of cognitive networks for understanding the principles of brain function. To date, research using the theory of complex networks in the study of the brain contributed to a deeper understanding of the general patterns of interconnection of different levels of its structural organization, and the involvement in these studies of the concept of

cognitive networks will take into account some of the features of the human creative functions.

Let us consider the peculiarities of the application of the theory of complex systems in the problems of cognitive linguistics. The first step in applying the theory of complex networks to the analysis of the text is the presentation of this text as a set of nodes and links, the construction of a language network. There are different ways of interpreting nodes and connections, which leads, accordingly, to different representations of the network of languages. Along with the sequential, “linear” analysis of texts, the construction of networks, whose nodes are their elements - words or phrases, fragments of natural language, can reveal structural elements of the text, without which he loses his connectivity. In this case, the task of determining which of the important structural elements are also important information, such as determining the information structure of the text, is relevant. Such elements can also be used to identify still poorly defined components of the text, such as collocation, paraphrase unity, for example, when searching for similar snippets in different texts.

We know several approaches to constructing networks of texts, so-called word networks, and different ways of interpreting nodes and relationships, which leads, accordingly, to different types of representation of such networks. The nodes can be connected to each other, if the corresponding words are next to the text, belong to the same sentence or paragraph, connected syntactically or semantically. Preserving syntactic relationships between words leads to the image of a text in the form of a directed network, where the direction of link corresponds to the subordination of the word.

Thus, if from a certain text (or another linguistic unit) a complex cognitive network (for example, a semantic graph) is created by a certain algorithm, then it is expedient to use the topological and spectral measures [10] of such complex cognitive networks and even trace their dynamics within the framework of the algorithm of the moving window [29, 30].

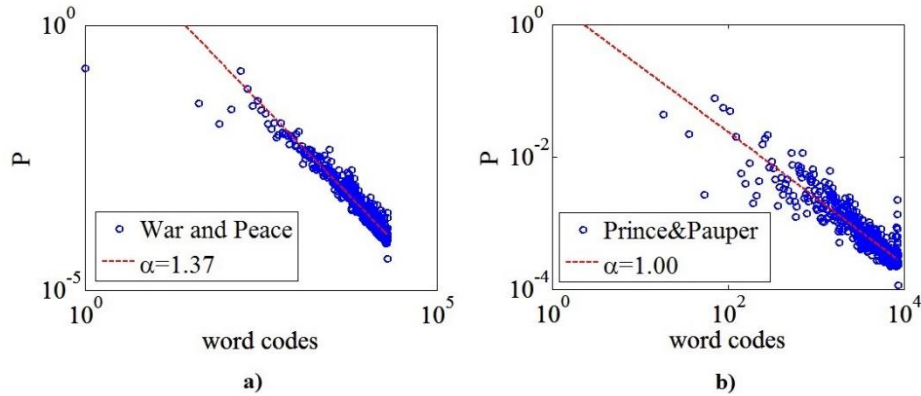
We will conduct a preliminary study of the frequency distribution of words in some well-known English-language literary works. The software developed by us analyzes the text of the work, creates a dictionary, each word of which has a unique code, in the process of analysis, the number of each of the words of the work is calculated, and also exports a text file of word codes that can be subjected to further analysis (frequency analysis, graph construction, its analysis).

Detailed results of the analysis of the spectral and topological properties of cognitive networks will be presented in a separate paper. At the same time, we will show only the fact that the constructed cognitive warnings convey the individual properties of complex networks in general.

In Fig. 6 on the logarithmic scale, the frequencies of words in the works are given. The linear trend corresponds to the distribution of  $\alpha$  from the Zipf law [26]:  $P(k) \sim ck^{-\alpha}$ .

It is known that in order to comply with the Zipf law, the index should be approximately equal to units. Execution on this linguistic unit (text) of a rank distribution of the type of the Zipf law may be a sign of “correctness” (a good organization) of this text taken as a whole. In this case, Twain’s novel is better organized, although this usually requires a wider and more profound analysis.





**Fig. 6.** The distribution of the frequency of words in the in novels of L. Tolstoy’s “War and Peace”,  $\alpha=1.37$  and of Mark Twain “The Prince and the Pauper” by,  $\alpha=1.00$

## 6 Conclusions

Thus, the modeling of social and humanitarian systems, the core of which is a cognitive component, can be carried out within the framework of a synergetic paradigm, the modern point of which is the theory of complex networks. The considered separate methods of the theory of complex systems demonstrate the possibility of quantitative analysis of cognitive functions. In particular, the results obtained in this paper suggest that informational (mono and multiscale), fractal and multifractal, as well as network measures of complexity can be used to quantify cognitive processes. This allows us to classify normal and anomalous phenomena, to offer a method for analyzing the cognitive trajectory over time, to model possible methods for its correction, taking into account external conditions.

In addition to the fundamental scientific significance – the understanding of the work of the human brain – work in this direction aims to overcome the general crisis of the educational system, the essence of which is the inadequacy of the goals, content, forms and methods of education new conditions.

## References

1. Rutten, N., van Joolingen, W.R., van der Veen, J.T.: The learning effects of computer simulations in science education. *Computers & Education*. **58**(1), 136–153 (2012). doi:10.1016/j.compedu.2011.07.017
2. Lamb, R., Premo, J.: Computational Modeling of Teaching and Learning through Application of Evolutionary Algorithms. *Computation*. **3**(3), 427–443 (2015). doi:10.3390/computation3030427
3. Mayor, J., Gomez, P. (ed.): Proceedings of the 13th Neural Computation and Psychology Workshop (NCPW13) on Computational models of cognitive processes. World Scientific Publishing, Singapore (2014)

4. Nikolis, G., Prigogine, I.: Exploring complexity: An introduction. W. H. Freeman and Company, New York (1989)
5. Kapitsa, S.P., Kurdyumov, S.P., Malinetsky, G.G.: Sinergetika i prognozy buduschego (Synergetics and prognoses of the future). Editorial URSS, Moscow (2003)
6. Arnold, V.I.: Matematika i matematicheskoe obrazovanie v sovremennom mire (Mathematics and mathematical education in the modern world). Matematicheskoe obrazovanie. 2, 109–112 (1997)
7. Harasim, L.: Shift happens: online education as a new paradigm in learning. The Internet and Higher Education. **3**(1–2), 41–61 (2000). doi:10.1016/S1096-7516(00)00032-4
8. Goh, W.P., Kwek, D., Hogan, D., Cheong, S.A.: Complex network analysis of teaching. EPJ Data Science. **3**:36 (2014). doi:10.1140/epjds/s13688-014-0034-9
9. The Future of Jobs Report 2018. [http://www3.weforum.org/docs/WEF\\_Future\\_of\\_Jobs\\_2018.pdf](http://www3.weforum.org/docs/WEF_Future_of_Jobs_2018.pdf) (2018). Accessed 24 Mar 2019
10. Solovjov, V.M., Serdyuk O.A., Danilchuk, G.B.: Modelyuvannya skladnih system (Modelling of complex systems). Vydavec' O.Yu. Vovchok, Cherkasy (2016)
11. Hausdorff, J., Zeman, L., Peng, C.-K., Goldberger, A.L.: Maturation of gait dynamics: stride-to-stride variability and its temporal organization in children. Journal of Applied Physiology. **86**(3), 1040–1047 (1999). doi:10.1152/jappl.1999.86.3.1040
12. Delignieres, D., Torre, K.: Fractal dynamics of human gait: a reassessment of the 1996 data of Hausdorff et al. Journal of Applied Physiology. **106**(4), 1272–1279 (2009). doi:10.1152/jappphysiol.90757.2008
13. Van Rooij, M.M.J.W, Nash, B.A., Rajaraman, S., Holden, J.G.: A fractal approach to dynamic inference and distribution analysis. Frontier in Physiology. **4**(1), 1–16 (2013). doi:10.3389/fphys.2013.00001
14. Ausloos, M.: Generalized Hurst exponent and multifractal function of original and translated texts mapped into frequency and length time series. Physical Review E. **86**(3). 031108 (2012). doi:10.1103/PhysRevE.86.031108
15. Liu, X.F., Tse, C.K., Small, M.: Complex network structure of musical compositions: Algorithmic generation of appealing music. Physica A: Statistical Mechanics and its Applications. **389**(1), 126–132 (2010). doi:10.1016/j.physa.2009.08.035
16. CompEngine. A self-organizing database of time-series data. <http://www.comp-engine.org> (2019). Accessed 24 Mar 2019
17. Schmid, U., Ragni, M., Gonzalez, C., Funke, J.: The challenge of complexity for cognitive systems. Cognitive Systems Research. **12**(3–4), 211–218 (2011). doi:10.1016/j.cogsys.2010.12.007
18. Bentz, C., Alikaniotis, D., Cysouw, M., Ferrer-i-Cancho, R: The Entropy of Words – Learnability and Expressivity across More Than 1000 Languages. Entropy. **19**(6), 275–279 (2017). doi:10.3390/e19060275
19. Hernandez-Gomez, C., Basurdo-Flores, R., Obregon-Quintana, B., Guzman-Vargas, L.: Evaluating the Irregularity of Natural Languages. Entropy. **19**(10), 521–621 (2017). doi:10.3390/e19100521
20. Keshmiri, S., Sumioka, H., Yamazaki, R., Ishiguro, H.: Multiscale Entropy Quantifies the Differential Effect of the Medium Embodiment on Older Adults Prefrontal Cortex during the Story Comprehension: A Comparative Analysis. Entropy. **21**(2), 199–215 (2019). doi:10.3390/e21020199
21. Wu, M., Liao, L., Luo, X., Ye, X., Yao, Y., Chen, P., Shi, L., Huang, H., Wu, Y.: Children Development Using Gait Signal Dynamics Parameters and Ensemble Learning Algorithms. BioMed Research International. 9246280 (2016). doi:10.1155/2016/9246280

22. Jiang, Z.-Q., Xie, W.-J., Zhou, W.-X., Sornette, D.: Multifractal analysis of financial markets. arXiv:1805.04750 [q-fin.ST]. <https://arxiv.org/pdf/1805.04750.pdf> (2018). Accessed 24 Mar 2019
23. Wijnants, M.L.: A Review of Theoretical Perspectives in Cognitive Science on the Presence of  $1/f$  Scaling in Coordinated Physiological and Cognitive Processes. *Journal of Nonlinear Dynamics*. 2014. 962043 (2014). doi:10.1155/2014/962043
24. Fan, C., Guo, J.-L., Zha, Y.-L.: Fractal analysis on human dynamics of library loans. *Physica A: Statistical Mechanics and its Applications*. **391**(24), 6617–6625 (2012). doi:10.1016/j.physa.2012.06.063
25. Albert, R., Barabasi, A.-L.: Statistical Mechanics of Complex Networks. *Reviews of Modern Physics*. **74**, 47–97 (2002). doi:10.1103/RevModPhys.74.47
26. Chen, H., Chen, X., Liu, H.: How does language change as a lexical network? An investigation based on written Chinese word co-occurrence networks. *PLOS One*. **13**(2). e0192545 (2018). doi:10.1371/journal.pone.0192545
27. Donner, R.V., Small, M., Donges, J.F., Marwan, N., Zou, Y., Xiang, R., Kurths, J.: Recurrence-based time series analysis by means of complex network methods. *International Journal of Bifurcation and Chaos*. **21**(4), 1019–1046 (2011). doi:10.1142/S0218127411029021
28. Webber, C.L., Ioana, C., Marwan, N. (eds.): Recurrence Plots and Their Quantifications: Expanding Horizons. Proceedings of the 6th International Symposium on Recurrence Plots 2015, Grenoble, France, 17-19 June 2015. Springer Proceedings in Physics, vol. 180. Springer International Publishing, Heidelberg (2016). doi:10.1007/978-3-319-29922-8
29. Soloviev, V., Belinskij, A.: Methods of nonlinear dynamics and the construction of cryptocurrency crisis phenomena precursors. In: Ermolayev, V., Suárez-Figueroa, M.C., Yakovyna, V., Kharchenko, V., Kobets, V., Kravtsov, H., Peschanenko, V., Prytula, Y., Nikitchenko, M., Spivakovsky, A. (eds.) Proceedings of the 14th International Conference on ICT in Education, Research and Industrial Applications. Integration, Harmonization and Knowledge Transfer. Volume II: Workshops, Kyiv, Ukraine, May 14-17, 2018. CEUR Workshop Proceedings, vol. 2014, pp. 116–127. [http://ceur-ws.org/Vol-2104/paper\\_175.pdf](http://ceur-ws.org/Vol-2104/paper_175.pdf). Accessed 24 Mar 2019
30. Soloviev, V.N., Belinskiy, A.: Complex Systems Theory and Crashes of Cryptocurrency Market. In: Ermolayev V., Suárez-Figueroa M., Yakovyna V., Mayr H., Nikitchenko M., Spivakovsky A. (eds) Information and Communication Technologies in Education, Research, and Industrial Applications. ICTERI 2018. Communications in Computer and Information Science, vol. 1007, pp. 276–297 (2019). doi:10.1007/978-3-030-13929-2\_14

# Computation Algorithm for Integral Indicator of Socio-Economic Development

Oleg Pursky<sup>[0000-0002-1230-0305]</sup>, Tetiana Dubovyk<sup>[0000-0001-9223-4629]</sup>, Iryna Gamova<sup>[0000-0002-2032-8578]</sup>, and Iryna Buchatska<sup>[0000-0003-2413-7370]</sup>

Kyiv National University of Trade and Economics, 02156, Kyiv, Ukraine  
o.pursky@gmail.com

**Abstract.** The computation algorithm for determination of the socio-economic development integral indicator based on the methods of factor analysis and expert evaluations has been described in the paper. By taking into account the knowledge and experience of experts, the factor model for evaluation of the level of socio-economic development has been improved. Based on the joint use of the methods of factor analysis and expert evaluation, the algorithm of automated computation for integral indicators has been developed. The approach has increased the reliability of the results of calculations and made it possible to analyze the correlations between indicators in terms of their influence on the overall socio-economic situation. The developed computation algorithm is used in the educational process within the framework of teaching the discipline "Prognostics of socio-economic processes".

**Keywords:** socio-economic development, integral indicator, factor analysis, expert evaluation.

## 1 Introduction

The main problem that arises when using methods of factor analysis in socio-economic studies is reliable conclusions. In statistical calculations, the importance of specific indicators for the socio-economic system is not taken into account. In this case, only the weighted average of such indicators is considered. This problem is solved by expert evaluation. Knowledge and experience of experts make it possible to rank the indicators in terms of their importance for ensuring the effective functioning of the socio-economic system. At the same time, however, expert evaluation fails to establish the correlation between socio-economic indicators. This task is successfully managed by the factor analysis.

Thus, in order to increase the reliability of the procedures for evaluation of the level of socio-economic development, there was a need to improve the mechanism for determination of the integral indicators on the basis of factor analysis by taking into account knowledge and experience of experts in the calculation procedures. It is an expert statistical option that is most suitable, since taking into account knowledge and experience of experts in calculations significantly increases the reliability of the conclusions obtained in the study. At the same time,

it gives a chance to perform an extensive socio-economic analysis by establishing correlations between indicators and to determine the influence of the change of a particular indicator (indicators) on the state of the system. Accordingly, within the framework of this study, the algorithm of automated evaluation of the level of socio-economic development has been developed on the basis of the joint use of the methods of factor analysis and expert evaluation.

## 2 Results and discussion

### 2.1 Mathematical model for determination of the socio-economic development integral indicator

In the framework of the presented studies, it is proposed to use a two-stage approach in order to calculate the socio-economic development integral indicator. At the first stage, the dimension of the initial feature space is reduced. Reducing the dimension of the feature space is based on the use of factor analysis [1, 2]. The approach is based on the transition from the description of a certain set of objects under study, given by a large set of indirect, directly measured features, to the description of a smaller number of maximally informative substantive variables (factors) that reflect the most important properties of the socio-economic phenomenon. In order to obtain such a reduced set of factors, one of the methods of factor analysis is used, namely the principal component analysis (PCA) [3].

The next stage is to obtain the one integral indicator based on the reduced set of independent factors, which would combine all these factors in the best way [4]. The determination of the most important factors makes it possible to optimize the process of making managerial decisions, and, as a result, improve the overall efficiency of the governance system.

Let us directly consider the model in which the factor is the estimated value, in other words, it represents a certain new characteristic of the studied set of objects. The description of the factor in terms of its connection with the set of initial indicators is in the form of an  $n \times m$  matrix of factors  $A$ , where  $n$  is the number of features,  $m$  is the number of factors. The basis for constructing the matrix of factors  $A$  is the  $n \times m$  matrix of pairwise correlations  $R$ . It reflects the degree of correlation between each pair of initial indicators, while the factor matrix characterizes the correlation between each of the  $n$  indicators and the  $m$  factors determined during the progress of analysis. In this case, the number of factors  $m$  should be significantly less than  $n$ , and the level of loss of informativeness is negligible.

We assume that there is a set  $G(i = 1, 2, \dots)$  of observations of a particular studied socio-economic phenomenon. In this case, the phenomenon is described by a set of  $n(j = 1, 2, \dots)$  features. That is, the information presented in the socio-economic study can be described as a  $G \times n$  matrix  $\Theta$ :

$$\Theta = \begin{vmatrix} \theta_{11} & \dots & \theta_{1j} & \dots & \theta_{1n} \\ \dots & \dots & \dots & \dots & \dots \\ \theta_{i1} & \dots & \theta_{ij} & \dots & \theta_{in} \\ \dots & \dots & \dots & \dots & \dots \\ \theta_{G1} & \dots & \theta_{Gj} & \dots & \theta_{Gn} \end{vmatrix}, \quad (1)$$

As a rule, the features selected to describe the socio-economic phenomenon have different dimensions, and therefore different scalability. In order to ensure the possibility of comparing the features of an object and avoiding the influence of their dimension, the initial data matrix  $\Theta$  is usually transformed (normalized), introducing a single scale for all features. The most common ways of obtaining a normalized data matrix  $Z_{ij}$  are standardization [4]:

$$Z_{ij} = (\theta_{ij} - \bar{\theta}_j) / s_j, \quad (2)$$

where  $\theta_{ij}$  is a value of  $j$ -th feature of  $i$ -th object;  $\bar{\theta}_j$  is an arithmetic mean value of  $j$ -th feature;  $s_j$  is a mean-square deviation of  $j$ -th feature (dispersion of  $j$ -th feature).

As a result of the standardization of the indicators, we obtain a  $G \times n$  matrix of the normalized values of the observations. Thus, a normalized matrix is obtained. Now it consists of vectors whose coordinates are indicators of socio-economic development.

According to the factor model [4], each of the features  $Z_j$  included in the study set can be represented as a function of a small number of common factors  $F_1, F_2, \dots, F_m$  and the characteristic factor  $U_j$ :

$$Z_j = f(F_1, F_2, \dots, F_m, U_j), \quad (3)$$

The application of factor analysis to the matrix of pairwise correlations between the initial indicators, on the basis of which the statistical weight of the factor is determined, makes it possible to represent the initial indicators by factors using the principal component analysis [3]:

$$Z_j = \sum_{p=1}^n a_{jp} F_p, \quad (4)$$

The coefficients  $a_{jm}$  are called factor loadings and characterize the significance of each of the factors for describing the  $j$ -th feature. Factor loadings are correlation coefficients between the initial indicators and factors. Let us write the expression (4) in vector form:

$$\mathbf{Z} = \mathbf{A}\mathbf{F}, \quad (5)$$

where  $\mathbf{F} = (F_1, F_2, \dots, F_n)^T$  is a centered random column-vector of uncorrelated principal components;  $\mathbf{Z} = (Z_1, Z_2, \dots, Z_n)^T$  is a centered random column-vector of initial features;  $\mathbf{A} = (a_{ij})$  is a nonrandom matrix of factor loadings of random values  $Z_i$  on the components  $F_j$  ( $i = 1, 2, \dots, n; j = 1, 2, \dots, n$ ).

We consider that  $\mathbf{\Omega} = \mathbf{M}(\mathbf{Z}\mathbf{Z}^T)$  is a covariant matrix of vector  $\mathbf{Z}$ . Being symmetric and positive definite, it has  $n$  positive eigenvalues  $\lambda_1, \lambda_2, \dots, \lambda_n$ . Let us assume that  $\lambda_1 > \lambda_2 > \dots > \lambda_n$ . We denote:

$$\Lambda = \begin{pmatrix} \lambda_1 & 0 & \dots & 0 \\ 0 & \lambda_2 & \dots & 0 \\ \dots & \dots & \ddots & \dots \\ 0 & 0 & \dots & \lambda_n \end{pmatrix}, \quad (6)$$

If  $\mathbf{x}_j = (x_{1j}, x_{2j}, \dots, x_{nj})^T$  are normalized eigenvectors-columns of matrix  $\mathbf{\Omega}$ , which correspond to their eigenvalues  $\lambda_j (j = 1, 2, \dots, n)$ , then for all  $j = 1, 2, \dots, n$  the following equalities are valid:

$$\det |\mathbf{\Omega} - \lambda_j \mathbf{I}| = 0, \quad (7)$$

where  $\mathbf{I}$  is an  $n$ -th order unit matrix. From this follows:

$$\mathbf{\Omega}\mathbf{x}_j = \lambda_j \mathbf{x}_j, \quad (8)$$

$$\mathbf{x}_p^T \mathbf{x}_j = \sum_{i=1}^n x_{ip} x_{ij} = \delta_{pj} = \begin{cases} 1, & p = j \\ 0, & p \neq j \end{cases}, \quad (9)$$

Let us introduce the matrix  $\mathbf{X} = (\mathbf{x}_1, \mathbf{x}_2, \dots, \mathbf{x}_n)$ . Since, taking into account (8) and (9)

$$\mathbf{x}_j^T \mathbf{\Omega} \mathbf{x}_p = \lambda_j \mathbf{x}_j^T \mathbf{x}_p = \begin{cases} \lambda_j, & p = j \\ 0 & p \neq j \end{cases}, \quad (10)$$

then

$$\mathbf{X}^T \mathbf{\Omega} \mathbf{X} = \Lambda, \quad (11)$$

Let us assume that

$$\mathbf{F}' = \mathbf{X}^T \mathbf{Z}, \quad (12)$$

and since

$$\mathbf{M}\mathbf{F}' = \mathbf{M}(\mathbf{X}^T \mathbf{Z}) = \mathbf{X}^T \mathbf{M}\mathbf{Z}, \quad (13)$$

then  $\mathbf{F}'$  is a centered vector, and since

$$\mathbf{M}(\mathbf{F}'\mathbf{F}'^T) = \mathbf{M}(\mathbf{X}^T \mathbf{Z}\mathbf{Z}^T \mathbf{X}) = \mathbf{X}^T \mathbf{M}(\mathbf{Z}\mathbf{Z}^T) \mathbf{X} = \mathbf{X}^T \mathbf{\Omega} \mathbf{X}, \quad (14)$$

then by virtue of (11) the components of the vector  $\mathbf{F}'$  are uncorrelated, and the dispersion of factors  $D$  is equal to

$$\mathbf{D}F'_j = \lambda_j (j = 1, 2, \dots, n), \quad (15)$$

that is,  $\mathbf{F}'$  is a vector of the principal components  $\mathbf{F}$ , which is calculated in accordance with (14) as follows:

$$F_j = \sum_{i=1}^n x_{ij} Z_i \quad (j = 1, 2, \dots, n), \quad (16)$$

Let us find the matrix of factor loadings  $\mathbf{A}$ . Using the orthogonality of the matrix  $\mathbf{X}$  and the equation (12) we obtain:

$$\mathbf{X}\mathbf{F} = \mathbf{X}\mathbf{X}^T\mathbf{Z} = \mathbf{X}\mathbf{X}^{-1}\mathbf{Z} = \mathbf{Z}, \quad (17)$$

taking into account (5) the expression (17) can be written as

$$\mathbf{A} = \mathbf{X}, \quad (18)$$

in other words, the factor loadings  $a_{ij}$  are the components of the eigenvectors  $x_{ij}$  of the matrix of pairwise correlation indicators.

In fact, for analysis,  $n' < n$  first principal components are used, which exhaust at least 60–70% of the initial random variables [3]. Within the framework of this model, one can use the mean-square deviation of factors as statistical weighting coefficients [4]:

$$\nu_i = \sqrt{D_i} \quad (i = 1, 2, \dots, n), \quad (19)$$

or if we take into account (15) we obtain

$$\nu_i = \sqrt{\lambda_i} \quad (i = 1, 2, \dots, n), \quad (20)$$

That is, for statistical determination of weighting coefficients it is possible to use calculated earlier eigenvalues of the correlation matrix of initial indicators. The larger the difference in the values of objects by factor, the greater the statistical weight of this factor.

The main disadvantage of statistical methods is the reliability of the conclusions, in particular, in this statistical mechanism of determining the integral indicators, the weight of the factor is determined by the dispersion of initial indicators, which is not always reliable in socio-economic studies, since in this case the importance of indicators for the socio-economic system is not taken into account. Therefore, in the framework of this study, in order to increase the reliability of the algorithm for evaluating the level of socio-economic development based on factor analysis, the implementation of an expert evaluation procedure in the mechanism of determining the weight of factors is proposed. The conclusions that change from method to method depend on the subjectivity of choosing the method of processing expert evaluations. In connection with this circumstance, it seems expedient in the automation procedures of expert evaluation of weighting coefficients of factors to make a simultaneous use of the method of median  $M_i$  and the method of scoring of indicators  $y_i$ . An important feature of this mechanism of ranking socio-economic indicators by various experts is the possibility of minimizing the factor of subjectivity of expert evaluations by virtue



of the following procedures: 1) finding the density of the correlation between an arbitrary number of ranked features; 2) finding the density between the results of ranking of the two experts; 3) evaluating the consistency of expert conclusions in a group of more than two experts.

In order to solve the first problem, as a rule, the Spearman's rank correlation coefficient is used [5, 6]. In order to estimate the proximity of the conclusions of two experts it is advisable to use the Kendall rank correlation coefficient [6]. For said purpose, evaluations of all possible pairs of any indicators are considered and their consistency is determined. In order to evaluate the consistency of expert opinions in a group of more than two experts, which is typical of our case, Kendall's coefficient of concordance [6] is most often used, which is calculated using the following formulas:

$$K_K = 12P_C / (L^2 m (m^2 - 1)), \quad (21)$$

$$P_C = \sum_{i=1}^m \left( \sum_{j=1}^L r_{ij} - \frac{L(m+1)}{2} \right)^2, \quad (22)$$

where  $L$  is the number of experts,  $m$  is the number of evaluated parameters,  $r_{ij}$  is the rank of the  $i$ -th element, assigned by the  $j$ -th expert.

The evaluation of competence is carried out with the help of a control examination, on the assumption that the correct answers to the questions are not known in advance. The mechanism is based on the processing of normalized scoring. The essence of the calculation is as follows:

1. The number of experts  $L_j$  is determined, who take part in the examination and must rank the indicators by means of their evaluation  $y_{ij}$ , for example, using a 10-point scale.

2. The amount of scores is calculated, determined by each expert on all indicators:

$$S_j = \sum_{i=1}^n y_{ij}, \quad (23)$$

3. A table of normalized scores for each expert is calculated, by dividing the points of each indicator by the expert's score:

$$\bar{y}_{ij} = y_{ij} / S_j, \quad (24)$$

4. The weighted sums of relative scores for each expert are calculated:

$$\bar{S}_j = \sum_{i=1}^n \bar{y}_{ij} \left( \sum_{i=1}^n \bar{y}_i / n \right), \quad (25)$$

5. The sum of the obtained weighted evaluations is calculated:

$$S = \sum_{j=1}^L \bar{S}_j, \quad (26)$$

6. The coefficients of expert competence are determined by dividing the weighted sum of the relative points of the expert into the total sum of the weighted evaluations:

$$K_j = \bar{S}_j / S, \quad (27)$$

7. The average group competence of experts is calculated:

$$K_{avg} = \sum_{j=1}^L K_j / L, \quad (28)$$

Experts, whose significance of their competencies is closest to the average group competence, are considered to be the most competent, and then the evaluations of only the most competent experts are taken into account. Thus, expert scoring evaluation of the  $i$ -th indicator on the basis of the joint use of the medians clustering and the method of scoring evaluations will be defined as:

$$Y_i = (M_i + y_i) / 2, \quad (29)$$

Then the weight of the  $i$ -th indicator evaluated by  $N$  most competent experts will be equal to:

$$c_i = Y_i / \sum_{i=1}^L Y_i, \quad (30)$$

and the weight of the  $i$ -th factor, according to expert evaluations, will be determined as the sum of the weight of each indicator included in this factor:

$$q_i = \sum_{j=1}^m c_{ij}, \quad (31)$$

where  $m$  is the number of indicators included in the  $i$ -th factor. As a result, we obtain a set of dimensionless coefficients  $q_i$ ,  $i = 1, 2, \dots, n$  ( $n$  is a number of factors).

It should also be noted that the proposed mechanism of expert evaluation makes it possible to implement program realization of the expert-statistical procedure for determining the weighting coefficients of factors. The generalized weight of factors that takes into account both the weight of the factor, determined on the basis of expert evaluations, and the weight of the factor determined statistically, can be obtained as the weighted average of these two evaluations [7]:

$$w_i = (\bar{q}_i + \bar{v}_i) / \sum_{i=1}^n (\bar{q}_i + \bar{v}_i), \quad (32)$$

where  $\bar{q}_i = q_i / \sum_i^n q_i$ ,  $\bar{\nu}_i = \nu_i / \sum_i^n \nu_i$  are expert and statistical (factor analysis) weighted coefficients of the factor, respectively. Thus, the integral indicator is calculated as the sum of factors with the corresponding weighted average weighting coefficients  $w_i$ :

$$I_j = \sum_{i=1}^n w_i F_{ij} \quad (j = 1, 2, \dots, n), \quad (33)$$

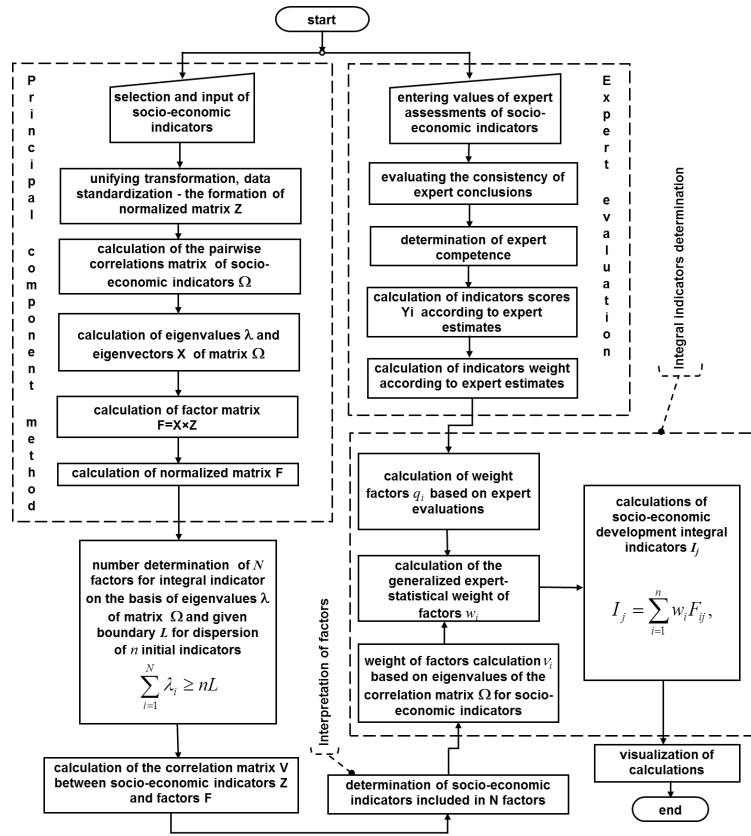
where  $n$  is a number of factors;  $F_{ij}$  is the value of the  $i$ -th factor for the  $j$ -th object. The best is an object with a larger value of the integral indicator.

## 2.2 Computation algorithm of the socio-economic development level

One of the main aspects of developed and existing models is ensuring the possibility of the processing automatization of socio-economic information on the basis of modern computer facilities. The presented model of determination of socio-economic development integral indicators formalizes the settlement procedures and makes it possible to develop an algorithm for automated data processing of socio-economic research, based on joint use of methods of expert evaluation and factor analysis. Figure 1 illustrates a general scheme of the developed algorithm for determining the socio-economic development integral indicator.

The initial stage of the algorithm is characterized by the entering of values of indicators of socio-economic development and expert evaluations. Thus, the initial data base is formed in the form of the matrix of indicators  $\Theta$  (1) and the matrix of expert evaluations of indicators. Data from statistical directories can be used as indicators. Further actions within the framework of the presented algorithm are related to realization of the principal component analysis and mechanisms of expert evaluation (Fig. 1). According to the principal component analysis, a matrix of indicators of socio-economic development is initially formed, followed by its reduction to a single scale of measurements. Then, bringing the indicators to the normal distribution law and calculating the matrix of pairwise correlations are carried out. For this matrix, its eigenvalues and eigenvectors are calculated. The following actions are associated with the multiplication of the normalized matrix of indicators and the matrix of eigenvectors, which results in a matrix of factors. Factors are normalized, the dispersion is determined for them. Further it can be used in the analysis of integral indicators.

The next stage of the developed algorithm for automated determination of socio-economic development integral indicators is the procedure for determining the number of  $N$  factors included in the integral indicator (Fig. 1) on the basis of a series of eigenvalues of the matrix of pairwise correlations of socio-economic indicators and the given boundary value  $L$  due to dispersion factors of normalized parameters. The contribution of factors in the description of the total dispersion of the entire set of  $n$  socio-economic indicators is compared with the given limit value  $L$  of the dispersion of the normalized parameters, with achievement of



**Fig. 1.** Scheme of the automated algorithm for determination of socio-economic development integral indicator.

which the factorization is stopped by the determination of  $N$  factors, or in other words - a sampling of the minimum number of factors with maximal eigenvalues  $\lambda_i$  is made, the sum values of which are not less than  $nL$ :

$$\sum_{i=1}^N \lambda_i \geq nL \quad (34)$$

It is also worth noting that for analysis, one should use such number of factors that exhaust at least 60 – 70% of the dispersion of the initial random variables [4], therefore the procedure described for determining the factors, that are included in the integral indicator by specification of the boundary value of  $L$  due to the dispersion factors of normalized socio-economic indicators, provides implementation of the mechanism of reducing the space of features without significant loss of informativeness, because  $N$  factors include the most important

socio-economic indicators. The relative contribution  $\% (F_i)$  of each of the  $N$  factors in the description of the total dispersion of all  $n$  indicators is determined as the ratio of the eigenvalue  $\lambda_i$  of the factor  $F_i$  to the total dispersion of the features, which is also equal to  $n$ :

$$\% (F_i) = \lambda_i / \sum \lambda_i = \lambda_i / n \quad (35)$$

The parallel branch of the algorithm (see Fig. 1) is associated with the program implementation of the expert evaluation mechanisms. For said purpose, initially, using the above procedure, the determination of the competence of experts is carried out, and then, by calculating Kendall's coefficient of concordance, one gets an evaluation of the consistency of their conclusions. Thus, as a result of the calculations, only the agreed conclusions of the competent experts remain. On the basis of these data, a group of experts is determined, the conclusions of which will participate in the evaluation. Using experts' performance of the ranking of indicators on the basis of the medians clustering and the method of arithmetic mean value, taking into account the competence of experts, the scoring evaluation of the indicators is calculated. Then, the weight of the indicators is determined according to expert evaluations [2].

The final stage of the algorithm is the determination of weighting coefficients, the calculation of integral indicators and the visualization of the results of data processing. Weighting coefficients for each factor are calculated by a combination of expert and statistical weight. The statistical weighting factors of the factors included in the integral indicator are determined by the formula (20), based on the eigenvalues of the pairwise correlations matrix of normalized socio-economic indicators. The expert weight of the factors included in the integral indicator is calculated by the formula (31). The generalized weight of the factors  $w_i$ , which takes into account both the weight of the factor, determined on the basis of expert estimates, and the weight of the factor determined statistically, we obtain by the formula (32). In order to directly determine the integral indicators, it is necessary to combine the calculated factors into a single indicator. Since all factors are independent, the combination is carried out using a simple linear convolution [4]. Thus, the integral indicator is calculated as the sum of factors with the corresponding weighted average weighting coefficients  $w_i$ , by the formula (33).

### 2.3 Modeling the process of regional socio-economic development assessing

Consider the process of assessing the level of regional socio-economic development in accordance with the developed computation algorithm for integral indicators of socio-economic development (Fig. 1) on the example of the Vinnytsia region districts.

According to the National State Statistics Service of Ukraine [8], one of the main socio-economic indicators that characterize the level regional development are (Table 1): Number of cars per 1000 people (P1); Services rendered per unit

**Table 1.** Normalized values of socio-economic indicators.

Districts	Socio-economic indicators										
	P1	P2	P3	P4	P5	P6	P7	P8	P9	P10	P11
Barsky	-0,190	0,028	0,225	-0,130	0,086	-0,235	0,044	-0,038	-0,154	0,052	-0,310
Bershadsky	-0,055	0,087	-0,070	0,182	0,006	0,294	0,003	0,034	-0,175	-0,246	-0,302
Vinnitsky	0,054	0,063	0,441	0,294	0,259	-0,083	0,951	-0,396	-0,325	-0,466	-0,236
Haysinsky	-0,063	0,430	0,067	0,169	0,230	0,013	0,014	-0,135	-0,188	-0,292	-0,328
Zhmerinsky	0,464	-0,136	-0,110	0,194	0,014	0,061	-0,018	-0,092	0,074	-0,227	0,126
Illinetsky	0,047	-0,144	0,185	-0,130	0,261	-0,195	-0,044	0,224	0,117	0,084	-0,065
Kalinovsky	-0,094	0,135	0,392	0,169	-0,159	-0,291	0,037	-0,271	-0,182	-0,174	-0,313
Koziatynsky	0,058	0,508	-0,041	0,157	0,036	0,254	-0,024	-0,207	-0,017	-0,179	0,001
Kryzhopol-sky	-0,022	0,283	0,067	-0,193	0,363	-0,115	-0,078	0,212	-0,041	0,097	-0,092
Lipovetsky	-0,152	0,016	0,205	0,119	-0,204	0,069	-0,021	-0,089	-0,080	0,063	-0,177
Litinsky	-0,109	-0,005	0,067	0,032	-0,243	0,053	-0,024	-0,142	0,158	0,054	0,084
Mohyliv-Podilsky	0,470	-0,110	-0,110	0,107	-0,046	-0,251	-0,070	0,046	0,197	-0,080	0,205
Murovanna-rurilotsky	-0,174	-0,217	-0,375	-0,205	-0,116	0,102	-0,087	0,312	0,223	0,185	0,246
Nemirovsky	-0,112	0,249	-0,129	0,182	0,335	0,053	0,002	-0,123	0,048	-0,155	-0,073
Orativsky	0,094	-0,223	0,038	-0,380	-0,204	0,190	-0,089	0,297	0,510	0,288	0,177
Pischancky	-0,152	-0,094	-0,119	-0,230	0,076	-0,147	-0,063	0,106	-0,018	0,237	0,308
Pogrebish-chensky	0,009	-0,015	-0,149	-0,230	-0,152	-0,067	-0,062	-0,166	0,276	0,142	0,086
Teplicky	-0,171	-0,121	-0,169	0,057	-0,269	0,118	-0,052	0,498	0,152	0,145	0,202
Tyvriivsky	0,053	0,009	0,038	0,157	0,159	-0,195	0,118	-0,094	-0,083	-0,013	0,098
Tomashpil-sky	-0,149	-0,101	0,067	-0,168	0,276	-0,011	-0,042	0,145	-0,148	0,083	-0,119
Trostryanetsky	0,276	-0,074	0,097	-0,068	-0,113	0,126	-0,076	0,056	-0,189	0,084	-0,083
Tulchinsky	0,098	0,189	-0,080	0,169	0,093	-0,139	-0,042	-0,145	-0,176	-0,141	-0,047
Khmelnysky	0,387	-0,294	-0,237	0,206	-0,033	0,286	-0,078	-0,004	0,319	-0,273	-0,005
Chernivtsky	-0,164	-0,110	-0,296	-0,417	-0,055	0,454	-0,069	-0,154	0,071	0,215	0,271
Chethelnitsky	-0,109	-0,183	-0,149	-0,105	-0,334	0,118	-0,079	0,024	-0,043	0,242	0,287
Shargorod-sky	-0,249	-0,167	0,244	0,132	-0,130	-0,283	-0,075	0,077	-0,091	0,121	-0,045
Yampilsky	-0,046	-0,004	-0,100	-0,068	-0,135	-0,179	-0,075	0,025	-0,236	0,154	0,103

of population, UAH (P2); Natural increase (reduction) of the population (P3); Registered unemployment rate (P4); Average monthly salary, UAH (P5); Provision of housing by the population,  $m^2$  per person (P6); The ratio of  $m^2$  of built housing to the population (P7); Preschool establishments per unit of population

(P8); General educational institutions per unit of population (P9); Number of crimes per 1000 people (P10); Emissions of pollutants (P11). It should be noted that the list of indicators, depending on the goals and objectives of the assessing, may change, thereby changing its emphasis. Thus, for the Vinnytsia region we have a matrix of initial socio-economic indicators in the size of  $27 \times 11$  (27 districts of the region and 11 indicators). Listed in a single scale of measurements and normalized (2) values of socio-economic indicators of districts are presented in Table 1. On the basis of the normalized matrix of socio-economic indicators (Table 1), the pairwise correlations matrix  $\Omega$  of indicators is dimensioned  $11 \times 11$ . For the pairwise correlations matrix of indicators, we determine eigenvalues  $\lambda$  (Table 2) and eigenvektors  $\mathbf{X}$ .

The matrix of factors  $F$  is obtained by multiplying the normalized matrix of socio-economic indicators (Table 1) into the matrix of the eigenvektors of the pairwise correlations matrix. The obtained factors are normalized by the formula (2). The normalized factor matrix is used to calculate the matrix of correlations between factors and indicators of socio-economic development, that is required for the interpretation of factors.

On the basis of the calculated eigenvalues of the pairwise correlations matrix  $\Omega$  (Table 2) and the given threshold  $L$  of the dispersion for normalized socio-economic indicators (Table 1), the formula (34) determines the number of  $N$  factors in the integral indicator. In this case, the number of main components (factors) must be used, which exhaust at least 60-70% of the variance of the initial random variables. For example, at a given threshold of 0.6, from Table 2 it is necessary to select  $N$  factors with maximal eigenvalues, the sum of values of which is not less than  $0,6 \times 11 = 6,6$ . The sum of the first three eigenvalues  $\lambda$  is 7.49, that is, the integral index consists of the first three factors ( $N = 3$ ) that explain approximately 68% (see formula 35) of the variance of the initial data (Table 2). The calculate matrix of correlations  $\mathbf{V}$  between the normalized socio-economic indicators and the factors shows, which indicators are included in the given three factors (with the value of the variance of the indicators should not be less than the given limit value of 0.6).

Table 3 shows the structure of factors: the coefficient of correlation between the indicators and factors in which they are included, statistical (20) and expert (31) weights coefficients and weighted average weight coefficient of factors (32). The first factor included the first four socio-economic indicators - 1) the number of cars per 1000 people; 2) services rendered per unit of population; 3) natural increase (reduction) of the population; 4) the level of registered unemployment. The second factor included the eleventh indicator - emissions of pollutants. The third factor entered the seventh indicator - the ratio  $m_2$  of the built housing to the population.

To calculate the integral indicators, it is necessary to implement the mechanism for determining weight factor factors using expert evaluation. The basis for calculations is a table with score points of socio-economic indicators, put forward by experts. As experts participating in the evaluation, employees of the Regional Economic Development Department of Vinnytsia Region State Admin-

**Table 2.** Eigenvalues of the pairwise correlation matrix of indicators.

$\lambda$	4,566	1,334	1,193	0,931	0,765	0,587	0,495	0,364	0,244	0,098	0,022
$\%(F_i)$	41,51%	12,12%	10,85%	8,46%	6,95%	5,34%	4,50%	3,31%	2,22%	0,89%	0,20%
$\sum \%$	41,5%	53,6%	64,4%	72,9%	79,9%	85,2%	89,7%	93,1%	95,2%	96,2%	96,4%

**Table 3.** Structure of factors and their weight coefficients.

Factors	Socio-economic indicators	Correlation coefficient	Statistical weight coefficient	Experts weight coefficient	Weighted average weight coefficient
F1	P1	0,805	2,137	0,016	0,370
	P2	0,814		0,015	
	P3	0,720		0,021	
	P4	0,680		0,053	
F2	P11	0,788	1,317	0,034	0,188
F3	P7	0,690	1,092	0,250	0,442

istration were used in this study. In order to minimize the subjectivity of expert assessments, an evaluation of the consensus of the experts' conclusions in the group and the definition of experts competencies is initially carried out. To do this, the Kendal Concordance Coefficient (KK) is used. Calculation is carried out by formulas (21) and (22). The result of calculating the coefficient Kendel shows that it is close to the unit  $KK = 0,815$ . That is, it can be concluded that expert assessments are consistent and the composition of the expert group need not be changed. To assess the competencies of experts, an approach based on the processing of normalized ball scores is used. First, on the basis of scores of experts, the amount of points calculated by a particular expert is calculated (23). Then, by dividing each ball into the sum of all the scores arranged by this esperty (24), we obtain a normalized ball scores of each expert. The average normalized value is calculated for each indicator. On the basis of the obtained results, by formula (25), we calculated the weighted sum of the relative points of each expert. In Table 4 the results of the weighted sum of expert assessments calculations are presented. Also, the sum of the weighted evaluations obtained by experts is (2.3463). Subsequently, by dividing the weighted sum of expert points by the sum of the weighted assessments of all experts, the competencies of each expert (27) and the average group competence of experts (28) are calculated. Analyzing the competencies of experts (Table 4), it is evident that 5 experts have competences that are closest to the group's core competencies. That is, the most competent experts are 1, 4, 10, 11 and 20 experts. It is the ballroom evaluation of the indicators by these experts (Table 4) will be used in the future for calculations.



**Table 4.** Weighted sums of relative ball scores and competence coefficients of experts.

Experts	Weighted sum of relative points	Competence coefficient $\beta$	$\Delta = \text{Average} - \beta$
Expert 1	0,1174	0,050036427	0,03643
Expert 2	0,1192	0,050809829	0,80983
Expert 3	0,1209	0,051535191	1,53519
Expert 4	0,1168	0,049768327	0,23167
Expert 5	0,1158	0,049374578	0,62542
Expert 6	0,1135	0,048393521	1,60648
Expert 7	0,1211	0,051600554	1,60055
Expert 8	0,1206	0,051397059	1,39706
Expert 9	0,1137	0,048441221	1,55878
Expert 10	0,1166	0,049692931	0,30707
Expert 11	0,1159	0,049407296	0,59270
Expert 12	0,1142	0,048666712	1,33329
Expert 13	0,1195	0,050940928	0,94093
Expert 14	0,1211	0,051628416	1,62842
Expert 15	0,1206	0,051400438	1,40044
Expert 16	0,1157	0,049319329	0,68067
Expert 17	0,1210	0,051574862	1,57486
Expert 18	0,1137	0,048445995	1,55401
Expert 19	0,1129	0,048119791	1,88021
Expert 20	0,1160	0,049446595	0,55341
<b>Summ</b>	<b>2,3463</b>	<b>Average 0,0500</b>	

**Table 5.** Group expert scores for indicators and and their weighting coefficients.

	P1	P2	P3	P4	P5	P6	P7	P8	P9	P10	P11
<b>Average</b>	0,062	0,053	0,074	0,168	0,164	0,065	0,053	0,066	0,070	0,053	0,172
<b>Median</b>	0,063	0,058	0,077	0,173	0,154	0,063	0,058	0,063	0,064	0,058	0,170
$Y_i$	0,062	0,055	0,075	0,170	0,159	0,064	0,055	0,064	0,067	0,055	0,171
$C_i$	0,016	0,015	0,021	0,053	0,063	0,034	0,034	0,045	0,057	0,061	0,250

Experts estimate the medians and the average values of ball scores for indicators. Based on the median and the mean values of the ball scores, the formula (29) determines the group expert scores for each indicator  $Y_i$  (Table 5). The expert weight of each indicator  $C_i$  is determined by the formula (30), their values are given in Table 5. The weight coefficient  $q_i$  of the factor is estimated by the experts (31), as the sum of the expert weight of each indicator included in this factor (see Table 3). The statistical weight coefficient  $\nu_i$  of factor is determined on the basis of the eigenvalues of the pairwise correlations matrix  $\Omega$  of normalized socio-economic indicators (Table 2) by the formula (20). The generalized weight of the factor  $w_i$  by the formula (32).

**Table 6.** Calculated factors and integral indicators of districts of Vinnytsia region.

<b>Districts</b>	<b>F3</b>	<b>F2</b>	<b>F1</b>	<b>Integral indicators</b>
Barsky	0,016	-0,079	-0,100	-0,164
Bershadsky	-0,116	0,028	-0,099	-0,187
Vinnitsky	0,119	0,019	-0,422	-0,284
Haysinsky	-0,153	0,004	-0,224	-0,374
Zhmerinsky	0,087	0,103	-0,012	0,179
Illinetsky	0,083	-0,038	0,021	0,066
Kalinovsky	0,079	-0,041	-0,213	-0,175
Koziatynsky	-0,190	0,053	-0,106	-0,243
Kryzhopolsky	-0,100	-0,049	-0,026	-0,175
Lipovetsky	0,004	-0,029	-0,050	-0,074
Litinsky	0,016	0,002	0,041	0,059
Mohyliv-Podilsky	0,164	0,070	0,050	0,284
Murovannarurilotsky	-0,026	-0,006	0,248	0,216
Nemirovsky	-0,144	0,023	-0,101	-0,222
Orativsky	0,061	0,001	0,272	0,334
Pischancky	0,004	-0,047	0,131	0,088
Pogrebishchensky	0,002	0,006	0,111	0,119
Teplicky	0,020	-0,010	0,193	0,203
Tyvriivsky	0,058	0,002	-0,076	-0,017
Tomashpilsky	-0,038	-0,056	-0,002	-0,096
Trostryanetsky	0,037	0,009	0,013	0,059
Tulchinsky	-0,032	0,020	-0,112	-0,124
Khmelnysky	0,053	0,129	0,063	0,245
Chernivtsky	-0,167	0,008	0,203	0,044
Chethelnitsky	0,018	-0,012	0,171	0,177
Shargorodsky	0,123	-0,072	-0,015	0,037
Yampilsky	0,021	-0,037	0,040	0,023

To calculate the integral index  $I_j$ , it is necessary to combine the calculated factors. Calculations made show (Table 3) that weighted average weight coefficients of factors are: 0,3697, 0,1881 and 0,4422 for 1st, 2nd and 3rd factors, respectively. By multiplying the obtained factors by the corresponding weighted average weight coefficients of factors, by formula (33) we obtain the values of integral indicators that allow to rank the regions in terms of their socio-economic status. In table 6 results of calculations of factors and integral indicators of social and economic development of districts of Vinnytsia region are presented.

### 3 Conclusion

In the presented algorithm of evaluation of the socio-economic development level, the increase of its reliability is not due to a growing number of sources of initial

data on the basis of which the factors are determined, but due to the implementation of expert evaluation procedure in the mechanism of determining weighting coefficients of factors. Thus, taking into account the knowledge and experience of experts in determining the weighting coefficients of factors, we introduce the importance of specific indicators in the factor model of the evaluation of the level of socio-economic development, or, in other words, the intensity of their influence on the state of the socio-economic system. The obtained correlation dependencies can be used, for example, to detect correlations between the indicators and features that determine the socio-economic development (regression) of individual regions, etc. The main advantages of the developed algorithm for determining the integral indicators are: the use of the whole set of initial data, which excludes the possibility of distorting the content of the socio-economic model; ensuring the possibility of operative work with large socio-economic data bulk; taking into account knowledge and experience of experts in building a single socio-economic development integral indicator. The proposed algorithm for the determination of integral indicators makes it possible to implement a unified approach to data analysis and to ensure the efficiency of constructing integral indicators. It should also be noted that in the context of processing automatization of socio-economic data, the expert-statistical algorithm proposed provides the possibility of program implementation of the procedure for determining the socio-economic development integral indicators. The developed computation algorithm is used in the teaching of the discipline "Prognostics of socio-economic processes" in conducting a laboratory workshop on the topic "Determining the level of socio-economic development on the basis of expert-statistical method" and "Modeling the influence of the socio-economic indicators values on the general level of regional socio-economic development".

## References

1. Theodore, W.: An Introduction to Multivariate Statistical Analysis. 3rd ed. Wiley-Interscience, Boston (2003)
2. Tacq, J.: Multivariate Analysis Techniques in Social Science Research: From Problem to Analysis. 1st ed. SAGE Publications Inc., Thousand Oaks (1997)
3. Dunteman, G.H.: Principal Components Analysis (Quantitative Applications in the Social Sciences). 1st ed. SAGE Publications Inc., Thousand Oaks (1989)
4. Zhukovskaya, V.M., Muchnik, I.B.: Factor Analysis in Socio-Economic Research. Statistic, Moscow (1976) (in Russian)
5. Beshelev, S.D. Gurvich, F.G.: Mathematical and Statistical Methods of Expert Estimates. Statistic, Moscow (1980) (in Russian)
6. Goldstein, H., Lewis, T.: Assessment: Problems, Developments and Statistical Issues. 1st ed. Wiley-Blackwell, Boston (1996)
7. Ustinovieius, L.: Determining integrated weights of attributes. J. Civ. Eng. Manag. **7**(4), 321–326 (2001). doi: 10.3846/13921525.2001.10531743
8. Verner, I.Yev. (ed.): Statistical Yearbook of Ukraine for 2017. State Statistics Service of Ukraine, Kyiv (2017)

# Simulation System in Educational and Career Guidance State Policy of Ukraine

Vitalii Pazdrii<sup>1,2,3</sup>, Petr Banschykov<sup>2</sup>, Victoria Kosyk<sup>4</sup>, Irina Tropina<sup>5</sup>  
and Oleksandr Hryshchenko<sup>1</sup>

<sup>1</sup> Company of Intellectual Technology, 12Zh, Heroiv Stalingrada, Kyiv, 04210 Ukraine

<sup>2</sup> Kyiv National Economic University named after Vadym Hetman, 54/1, Peremogy avenue,  
Kyiv, 03057 Ukraine

<sup>3</sup> University of Management of Education, 52A, Sichovykh Strileiv str., Kyiv, 04053 Ukraine

<sup>4</sup> The Junior Academy of Sciences of Ukraine, 38-44, Degtyarivska str., Kyiv, 04119 Ukraine

<sup>5</sup> Institute of education content modernization, 36, Metropolitan Vasyl Lipkovsky str., Kyiv,  
03035, Ukraine

pazdriy.v@gmail.com, spgban@gmail.com, bpg@kneu.edu.ua,  
kosik0071@gmail.com, sevennn@ukr.net, gaalav@gmail.com

**Abstract.** This short paper described experience of using business-simulation into education and entrepreneurship supporting state policies. We are talking about All-Ukrainian business-tournament “Strategy of Firm”, which open opportunities for mass entrepreneurship education for young 13-17 years old. Continuation of tournament became state experiment project “Development business education in Ukraine as part of entrepreneurship supporting state policy”, which had started from schools in Kropyvnyckii (Central Ukraine).

**Keywords:** business-simulation, ViAL+, education, career-guidance, state policy, Strategy of Firm, business tournament, business school, ICT.

## 1 Introduction

In modern conditions of transformation in Ukraine there was a need to reform the system of economic education in schools. This step help young people better adapt to education at the university, modern labor market and new uncertainty world. Using of practical business competencies help build by youth their effective career. The need of development of entrepreneurship for youth as disclosed in the strategic document “Europe 2020”, based on three “pillars”: “Community of Innovation”, “Mobile Youth” and “New Abilities and Work” programs. These strategic documents were the impetus for the implementation of concrete steps in the field of business education. Also youth of Ukraine have need in entrepreneurial competence (more 55% of pupils from 13 to 17 said, that they vey wanted to receive skills of entrepreneurship) [1] and competence of entrepreneurship became priority of New Ukrainian School and new Law about Education.

The main problem of choose of occupation by youth in post-soviet countries is their indetermination. For example, many youth dream about business. But they don't understand all aspects of starting and realizing business, what skills they need for this. To remedy this situation, it is very important theoretical and practical education of entrepreneurship. And its must become part of educational and entrepreneurship supporting state policies. There are many ways for practical realized of his purpose. But our view is, there is very effective game and simulation technology as part of entrepreneurship education. And Ukraine has a lot of different projects in this sphere: facultative school of entrepreneurship, lessons of economics, tournament of economics, competition of business plans etc. But we describe only practical oriented steps: business tournaments, business-lessons, mass business-schools for youth, in which used simulation technology.

## **2 Ukrainian Business-simulation ViAL+ as technology of entrepreneurship education**

Business Simulation ViAL+ is a computer simulation system that creates a virtual economic environment by realistic reconstitution of industrial enterprises and creates a "live" competitive environment between the participants (Fig. 1). The main goal of the ViAL+ is forming of practical skills of problem-solving and decision-making in economic, management of production, distribution and competition at the market environment. Upon receiving a complete administrative and economic management of enterprise, the Participant receives the right of individual access to independent management of the enterprise main functions:

- organisation of production processes;
- main funds formation and management;
- staff recruitment and management;
- development and exploring of new kinds of products;
- management of production processes;
- management of product consumer appeal;
- marketing;
- organization of distribution;
- financial management of the enterprise, including through access to credit and deposit instruments;
- production efficiency increase;
- organization of accounting and formation of the company's balance sheet.

Participation in ViAL+ have four stages. The first during the period of 3-4 sessions participant in business simulation ViAL+ adapt to the simulation environment. Then the participation in business simulation ViAL+ gives an integrated vision of the company as a system, which, simultaneously, consists of interrelated functional units (8-10 sessions), an understanding of the cause-and-effect relations in economic management of the company in a competitive market environment (15-18 sessions). When the participant can consciously implement and correct the earlier formed plan of

action, he begins professional analysis of the results (after the 20th session). The reinforcement of acquired competences and practical skills is observed after 25 sessions.

Usually during the traditional career consultation teenagers are passive observers. Business Simulation ViAL+ turns them into the main creators of the competitive situation in the industry, immersed in the management activities. They win or lose as a result of their own decisions, learn to take into account the large amounts of diverse information and to concentrate on the minimum critical factors.

ViAL+ can open ways to practical entrepreneurship education, real choose occupation in economic, management an entrepreneurship spheres and also help to organise innovative events—business-tournaments, business schools and trainings, re-innovate economic education.

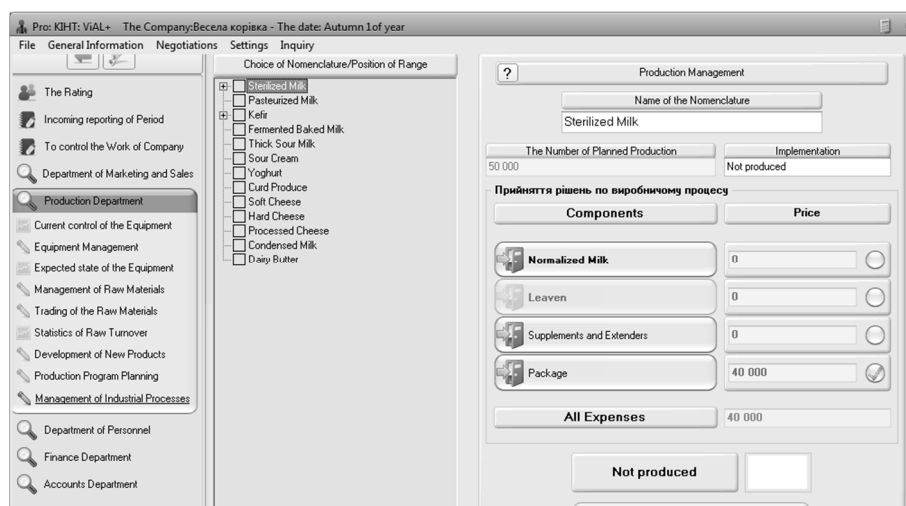


Fig. 1. Interface of User Module of business simulation ViAL+

### 3 Regular all-Ukrainian business-tournament “Strategy Firm”

All-Ukrainian Business-Tournament “Strategy Firm” is regular on-line tournament of making decision of management firm in business simulation ViAL+ from start to successful. Participants manage real economic processes at the competition between other participants. Main goal is build most profitably and effectively company and win competitors.

All processes of tournament are computer-aided and winners are determinate by automatic rating (consist from 12 indicators of results company – profit, market share, liquidity, profitability, using of resources). Participators must decide many realistic tasks in virtual conditions. During period of taking part on tournament participators form basic professional and life-need competences. Our tournament helps pupils

choose their occupation and specialization and increases students and teachers professional competences. This event is really example of career guidance tournament.

“Strategy Firm” became traditional in Ukraine and started new forms of partnership between economic universities, schools, gymnasiums, lyceums, businesses, local communities, local and state government (departments and Ministry of Education and Science) in questions of entrepreneurship education and choosing of occupation by youth. Turnir are supported by Ministry of Education and Science, Kyiv National Economic University, Company of Intellectual Technologies, NGO “Poruch”, Coca-Cola Hellenic, KPMG, METRO Cash&Carry, Kirovohradska Chamber of Commerce and Industry. The award ceremonies held in the Main Hall of Ministry of Education of Ukraine with the participation of heads of educational institutions. All finalists were awarded valuable gifts and monetary incentive.

Target groups are pupils, students, teachers and educators, families, who want to run business or/and rising by career from all regions of Ukraine and neighbours countries. There are 4 leagues such as Pupils, Students Leagues, League of Teachers and Family Leagues. Main stages of tournament are:

1. Online registration at the site: kint.com.ua until to third Monday of February.
2. Online selection stage – third Monday of February each year and three weeks duration – all registered, winners – 400 semi-finalists.
3. Online semi-final – three weeks after selection stage – 400 semi-finalists – to be defined 20 finalists at each league.
4. Offline final – third Wednesday-Friday of April – 80 finalists – 3 winners in each leagues.
5. Open and close tournament take place at the Ministry of Education and Science.

Throughout the tournaments were been posted more 750 press releases. On 2019 was registered 1,930 participants from 25 regions of Ukraine (including Donetsk, Luhansk regions, Poland, Estonia). Number of participants increase in 20 once from 126 in 2014 to 3000 in 2018. And generally we have 10889 participants during 2014-2019 (Fig. 2).

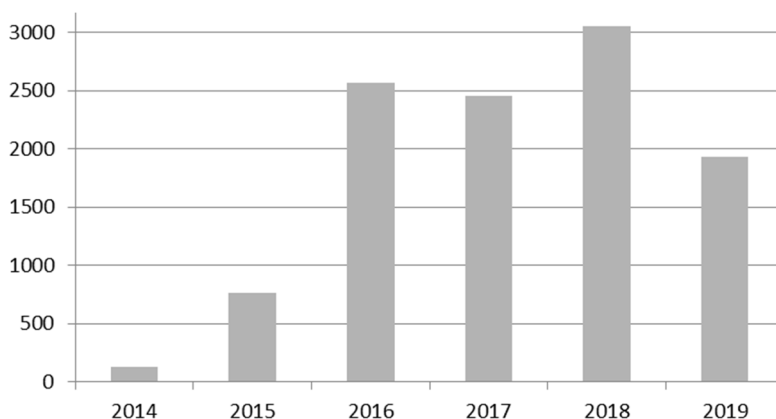


Fig. 2. Dynamics number of participants of tournament 2014-2019, persons

It became result of wide cooperation with Ministry of Education and Science, business and local communities. But in centre of all steps was understanding of needs entrepreneurship skills for youth and their future. This understanding providing to realization of state policy.

The participants said that tournament had helped to discover economics and business, to choose occupation spheres, to meet new friends from all Ukraine.

#### **4 Experiential science and applied project “Development of Business Education in Ukraine as an Element of the State Policy of Promoting Entrepreneurship Development”**

The next step of improving of business simulation technology to education became Decree of the Ministry of Education and Science of Ukraine No. 1221 dated 07.10.2016 “On carrying out experimental work of the all-Ukrainian level on the topic”. Development of business education in Ukraine as an element of the state policy of promoting entrepreneurship development [2]. According of this decree we start to draw up education programs for 8-11 classes (for pupils 13-17 years) as facultative, to continue organize locals and All-Ukrainian business-tournaments, to improve school of business leadership, to organize science and applied researches and other activities.

There were many projects of development of entrepreneurship education in Ukraine. But all they have failing— using of theoretical education without really practice [3]. And we know that entrepreneur will become only by practical. Our project is oriented by theoretical and practical education with using of business-simulation.

Ukrainian and foreign scientific researches show that the most effective is business education with simulation system, which is carried out in a competitive environment, developing healthy ambitions of young people, interested and motivating it to productive activity [3, 5, 6]. In addition, an improved system of school business education will enable for youth work in a team, to communicate effectively with partners and competitors, to negotiate with other people. At a time when young people are extremely lacking in communication, this is especially true.

The main idea of the research is forming methodological approaches to the introduction of entrepreneurship courses with simulations and games into school programme for 8-10 classes. These courses develop the skills of economic literacy, entrepreneurship, clear professional positioning and the development of accompanying “soft skills”: self-discipline, presentation, self-motivation, entrepreneurship, initiative.

The hypothesis of experimental work is business education in Ukraine needs some reform to ensure the most effective formulation and implementation of business knowledge in the business environment. The state educational policy can't be separated from the requirements of society and the priorities of the country, and therefore the practical significance of the experiment is to substantiate the innovations in the approaches to state regulation of entrepreneurship development by learning in the context of European integration processes. By this time in Ukraine more attention was paid exclusively to the economic and legal regulation of the functioning of



entrepreneurship, and not to the educational preparation and education of the entrepreneur himself. In view of this, the program will develop and substantiate recommendations for optimizing organizational relations between the subjects of management in the system of state regulation of entrepreneurship and education system; Their mutual influence was identified for the purpose of business development by consolidating the efforts of the state, public and business environment, forming and providing educational services to the stakeholders.

Technology of experimental science and applied project “Development of Business Education in Ukraine as an Element of the State Policy of Promoting Entrepreneurship Development” are business-simulation ViAL+.

The tasks of research are:

- carry out systematic analysis of domestic and foreign scientific literature, normative documents on the subject of research;
- to identify existing models of business education, to investigate their characteristics and efficiency in the conditions of the globalization of the world educational space;
- analyse the development of business education abroad;
- to reveal the economic significance of business education in the conditions of transformation of the national economy;
- to offer directions for the development and improvement of the management of the branch of business education in Ukraine;
- to substantiate the model of business knowledge formation with the help of education and science, business environment, civil society;
- to create and test a new course with using of business-simulation on business education in educational institutions;
- to prepare educational and methodological materials on the results of the introduction of innovative technology - business simulation - in the conditions of the organization of educational process of the educational institution;
- provide organizational, technical, and informative resources for immersing a student in the business environment by using business games and business simulations, as a result of which the student has the opportunity to feel differently in managerial roles with subsequent internships in business subjects.

During first stage of project were created and improved:

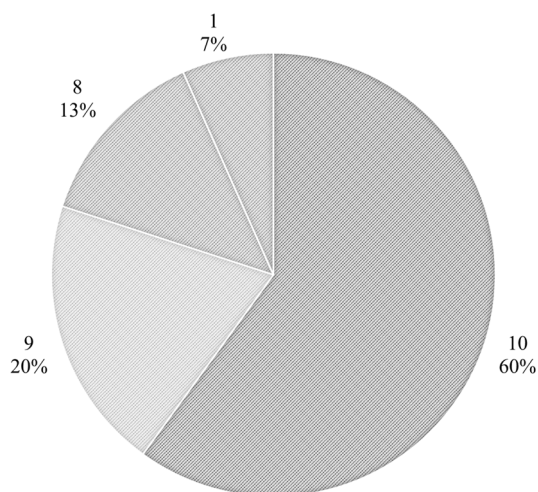
- program and lesson for pupils of 8-11 classes for 6 schools of Kropyvnyckii as pilot project;
- open lessons and competitions of advertising, products for pupil’s trainings companies. Participants of this events were pupils and teachers. But experts of competitions were owners, TOP-managers of TOP companies of Kropyvnyckii and Ukraine, Deputy of Ukrainian Parliament, local political and public activities;
- 4 local business-tournaments at the winters 2016-2018 years were classic competition of entrepreneurial and managerial skills such as All-Ukrainian Business-Tournament “Strategy Firm”;
- two Summers Schools of Business Leadership for teenagers 13-17 years old during 2-23’rd of June’17 and 1-20’th of June’18. Near 360 teenagers became participants

of this events. Summer School Business Leadership became innovative form of summer school for Ukraine. Program of School consisted of five parts: 1) theoretical training; 2) practical training in Business-simulation ViAL+ and 3) preparing advertising clips; 4) excursions to largest, middle and small enterprises; 5) consulting real farmer company.

- Entrepreneurship Forum 24<sup>th</sup> of November’18 – more 250 participants, includes first persons of politic, business elite and teachers, principals of schools.

There were 220 pupils of 16 classes of 5 schools became first participants of experimental projects. Teachers O. Zadorozhnij, S. Pustovoyt, O. Shylo became first who developed and improved businesses lessons in Kropyvnyckii. During 2017-2019 will be created programs for 9-11 classes and also scaled projects for other schools.

After finished courses of business we questioned pupils. And near 78-80% of pupils evaluated themselves level of business-skills as good and very good (8-10 point from 10). 80% of pupils said that facultative very useful (points 9-10 from 10, Fig.3). And near 90% said that want to continue lessons. 72,2% of participants very liked of taking part in Business-simulation ViAL+.



**Fig. 3.** Result of assessments of usefulness of business-lessons for pupils of 8 classes (self-assessments) from 1 to 10)

Very interesting were became open business lessons, Entrepreneurship Forum and other events for managers, owners, public local and all-Ukrainian leaders, municipal managers. Pupils spoke about their strategies and advertising campaign of trainings companies into Business-simulation ViAL+. For adults it was became shock. Because, in post-soviet school don't speak business, entrepreneurship, economy and aspects of managing of company. This situation is very crazy for Ukrainian education. And we educate and form life-oriented skills. But our events became real practice coordinate efforts of secondary and high education, business, public government and community.

For Ukraine, it is very seldom and sometimes unreal practice. We can do this. And experimental projects are continued.

## 5 Conclusions

Entrepreneurship education and providing ICT, simulation technology are important part of education state policy. Because we really forming economic active and initiative youth for Ukraine. And in future these persons make decisions in policy and forming state and local budget as employee and employers.

But, regardless of many successful stories and practice we have serious challenges in providing of business-simulation in education and career guidance practices:

- Troubles in preparing of IT-infrastructure of Ukrainian schools: old computers, not quickly Internet and others.
- Low level of computer preparing of teachers.
- Lack of money for projects. All initiatives were only volunteering and initiatives of some leaders and activities. But we haven't money supporting from state or local governments. Also business support by expert not money.
- Very high level of conservatism of teachers, business-leaders, public and society leaders. They sometimes think that business-simulation and ICT cannot educate of business. In some aspect, it's true. But business-simulation can build base for forming entrepreneurial minding and skills.
- Teachers aren't mental preparing to educate entrepreneurship and to use business-simulation in trainings.
- Low information interest of media to education events in Ukraine. Main topics of news are war at the East, scandals, negative events. But positive and useful practices are marginal on media.
- Generally low level of entrepreneurial and business culture in post-soviet countries.

For development entrepreneurship education and providing of business-simulation we must:

- Active information campaign for forming positive and corrective attitude to entrepreneurship.
- System of trainings about ICT and simulation technologies, entrepreneurship for teachers, directors and their deputies, specialists in educational methods, pedagogical scientists.
- Popularized business tournaments and mass business schools for open opportunities for entrepreneurship education.
- Development IT-infrastructure and change computers at the schools by using Ukrainian budget and European grants.
- Providing real computer courses for teachers and directors of schools.
- Providing individual parts of entrepreneurship education into New Ukrainian Schools.

## References

1. The New Ukrainian School. Conceptual principles of secondary school reform. <https://mon.gov.ua/storage/app/media/zagalna%20serednya/Book-ENG.pdf> (2016). Accessed 21 Mar 2019
2. Decree of the Ministry of Education and Science of Ukraine No. 1221 dated 07.10.2016 “On carrying out experimental and experimental work of the all-Ukrainian level on the topic “Development of business education in Ukraine as an element of the state policy of promoting entrepreneurship development”. [https://web.archive.org/web/20170401093411/http://old.mon.gov.ua/files/normative/2016-10-11/6293/nmo\\_1221.pdf](https://web.archive.org/web/20170401093411/http://old.mon.gov.ua/files/normative/2016-10-11/6293/nmo_1221.pdf) (2016). Accessed 21 Mar 2019
3. Bobinskaya, E., Shiyani, R., Tovkalo, M. (Eds.): Lessons with an Entrepreneurial Background: Educational materials. Owl, Warsaw (2014)
4. Kobernik, O.M. Theoretical and methodical principles of the competence approach in technological education. Modern information technologies and innovative methods of training in the training of specialists: methodology, theory, experience, problems. 37, 85–91 (2014)
5. DeSeCo. Definition and Selection of Competencies. Theoretical and Conceptual Foundations. <http://deseco.ch> (2016). Accessed 21 Mar 2019
6. Liashenko, M.: Formation of entrepreneurial competence of future teachers of technology. <https://www.cuspu.edu.ua/ua/ntmd/konferentsiy/conf-problemy-ta-inovatsii/sektsiia-2/4740-formuvannya-pidpryyemnytskoyi-kompetentnosti-u-maybutnikh-uchyteliv-tekhnologiy> (2016). Accessed 21 Mar 2019

# Using Computer Simulations and Games in Engineering Education: Views from the Field

Muhammet Demirbilek<sup>1</sup>[0000-0001-7448-9206] and Durmuş Koç<sup>2</sup>[0000-0001-8719-444X]

<sup>1</sup> Suleyman Demirel University, Isparta, 32260 Turkey

<sup>2</sup> Uşak University, Karahalli MYO, Karahalli, Uşak, 64700, Turkey  
mdbilek@gmail.com, akindurmuskoc@gmail.com

**Abstract.** The purpose of this research is to determine the views of the faculty of engineering and architecture academic staff on the use of educational computer simulations and games in engineering education. The research data were collected using semi-structured interview technique in qualitative data collection method and analyzed conducting the context analysis method. The analysis of the data revealed that academic staffs of engineering and architecture faculties have positive approach to the use educational computer simulations and games in their courses; however they could not be able to employ the games in their class due to deficiencies of the games and simulations appropriate for the curriculum and lack of games in Turkish. Furthermore, using educational computer games and simulations in the engineering courses may improve the quality of instruction, motivate students and make courses more enjoyable according to academic staff views.

**Keywords:** Engineering education, Simulations, Game based learning, Computer games and simulations

## 1 Introduction

In recent decades, there have been major developments using technology in engineering education. However, engineering education in Turkey is not keeping pace with the complex and highly dynamic of technological advances in its curriculum and instructional methodologies. Therefore, there is a need to reconsider investing more time and effort in developing new methodologies that takes into account academic staffs' opinions about what should be included in engineering curricula. Computer-assisted learning is an approach to teaching and learning in which computer technology is used as an aid to the presentation, reinforcement and assessment of material to be learned, usually including a substantial interactive element [19]. The traditional teaching environment is a classroom: a single teacher giving lectures to a group of students who are expected to use their notes and textbook to prepare for periodic examinations and demonstrate their mastery of the subject. Furthermore, individuals of in engineering courses in higher education often experience a lack of motivation, partly caused by traditional teaching methods. The use of computers in education shifts the focus away from the teacher to the students themselves who learn through

experimentation on the computer with the teacher acting only as a guide.

### **1.1 Educational Games and Simulations**

When the learning is active, situated, experiential, problem-based, and provide immediate feedback, it is known to be most effective [5]. Most of the engineering courses in higher education do not meet with these features. A typical engineering course consists of a traditional lecture where concepts and theories are taught as a part of passive learning. Most of the assigned projects are very structured and constrained which does not prepare students adequately for the future jobs [20]. One promising approach to increase students' motivation is the introduction of educational digital games and simulations into engineering courses. Educational digital games play a role in future education because students are already integrating technology into their free time at a speed which is not grasped by schools [16]. Administrators who seek to encourage faculty to integrate digital games into their everyday science courses can refer to the study as a reference demonstrating the current adoption of digital games and simulations in teaching. The digital games provides the field of education with innovative opportunities that instruct the learner through engagement by providing an ideal multimedia tool that present concepts in a manner that is engaging, fun, and motivating [18], [21]. Furthermore, digital games promote constructivist principles by allowing the learner to engage in immersive worlds and take ownership of knowledge [3]. Problem-solving experiences embedded within computer games provide the learner with a safe place to fail and experiment with the material as learners encounter new knowledge [9]. In addition, digital games for learners provide with an interactive student-centered environment in order to create a personalized learning experience, progressively incorporating new knowledge and scaffolding it into what students already know.

Simulation can be defined as the use of a computer-generated system to represent the dynamic responses and behavior of a real or proposed system. Computer simulations are used to study the behavior of objects or systems that cannot be easily or safely tested in real life, such as weather patterns or a nuclear blast. The playing of games simulates actual conditions (as of business or war) especially for training or testing purposes. Games can be defined as simulations for entertainment. Simulations are the teaching and learning tools because they are cost effective, repeatable and easy to modify. Simulation is the simplification of the operation of a real world process or system over time [2]. It is a model of systems or processes that include defined relationships between system objects. The aim of an educational simulation is to motivate students, to engage problem solving, experiential learning, and development of mental models [22], [8]. In order to utilize learning, educational simulations rely on scaffolding [8], coaching, and feedback [10]. Simulation provides objective information about the processes that are available today and more importantly tomorrow. Simulation is an imitation of a real thing. Simulation is a computer-assisted modeling of a real event. For example, a flight simulator on a computer is a simulation model used to teach some rules of flight on a computer. It is a simulation event that the pilot will see the screen in the cockpit as he / she sees a similar on the computer screen

and acts as if he is really on board. Flying by simulating the simulator is safer and cheaper than flying with a real plane. The reasons for using models in industry and industry, the low cost, the non-dangerousness and the experimentation on real systems are sometimes impossible. Experimenting on models similar to real systems means saving money and time.

### **1.2 Using Educational Computer Games in Engineering Education**

Radical changes in the world in engineering education in the use of technology experienced engineering education in Turkey is difficult to say how you feel sufficiently the impact of these developments. In this context, to raise awareness of faculty members on the use of current teaching technologies in higher education, especially in engineering education will be an important source for the decision makers in this field. In our country, engineering education cannot meet the expectations due to the economic problems, the attitudes of the instructors and the lack of basic knowledge of the students [1]. This situation shows that alternative education methods are needed in engineering education [13].

### **1.3 Using Educational Computer simulations in Engineering Education**

Simulations are instructional scenarios where the student is placed in a simulated condition representing a reality within which students interact. The instructor controls the parameters of this “world” and uses it to achieve the desired instructional results. Students experience the reality of the scenario and gather meaning from it. Simulation is a form of experiential learning. Therefore, it is a strategy that fits well with the principles of constructivist learning and teaching. Simulations may contain elements of a game, a role-play, or an activity that acts as a metaphor. They are characterized by their non-linear nature and by then controlled ambiguity within which students must make decisions. The inventiveness and commitment of the participants usually determines the success of a simulation. They promote the use of critical and evaluative thinking of engineering students. They promote concept attainment through experiential practice in engineering education setting. Simulations may help students understand the differences of a concept. Engineering students often find them more deeply engaging than other activities, as they experience the activity first-hand, rather than hearing about it or seeing it. Research on the impact of computer games on learning has generally focused on academic achievement and motivation in primary and secondary education [17], [11], [7], [12]. For instance, Kula and Erdem [12] investigated the effects of educational computer games on the development of basic arithmetic processing skills of elementary school students. It was found that the effect of the educational game used in the study on the development of the basic arithmetic processing skills of 4th and 5th grade students was not statistically significant. However, it is among the findings of the study that the students have increased their tendency to perform complex collection procedures after the application. In addition, students have shown positive opinions about the motivation and teaching of computer games. On the other hand, Bayırtepe and Tüzün [4] examined the effects of educational

computer games on primary school students' achievement in computer courses and self-efficacy perceptions. There was a statistically significant increase in the students using the game-based learning environment according to the results of the achievement test before and after the practice. However, there was no significant difference between the students' learning environment and the success in the learning-based learning environment and the computer self-efficacy perceptions. In this environment where computer hardware is learned, it is seen that students have a positive approach to the use of game-based environments. Although studies on game and simulation use in engineering education in the world have increased recently, there is a limited number of studies. Turkey also noteworthy in engineering education is the scarcity of studies on the use of games. The purpose of this research; to expose the views of faculty members in engineering and engineering faculties on the use of educational computer games in engineering education. The research question of the study; What are the opinions of the academic staff working in engineering faculties about the usage of computer games, usage places, usage purposes, features of the games used and usage advantages in course activities? This study will seek answers of these questions.

## **2 Method**

The purpose of this research is to determine the views of the faculty of engineering and architecture academic staff on the use of educational computer games in engineering education. The research data were collected using semi-structured interview technique in qualitative data collection method. Interviews were conducted to eleven faculty members of engineering and architecture faculty at Suleyman Demirel University (SDU). Data patterns of the interviews were analyzed employing content analysis method of the qualitative research. Before the interview questions were prepared, national and international studies related to the research subject were screened and the items that were intended to be included in the interview form were determined. The questions included in the interview form. The three faculty members who have knowledge and experience were asked to be evaluated in order to evaluate whether they are suitable for the purpose, meaning and scope of the study and to give feedback on scope and surface validity [15]. Interview questions were arranged by considering the feedback. In addition, it was seen that the interview form was completed and the interview form was finalized as a result of the pre-application with two other faculty members of the faculty of engineering. The interviews were conducted with 11 faculty members working in Faculty of Engineering and Faculty of Architecture at SDU. In the selection of the faculty members, easily accessible situation sampling method was used. Easy-to-reach status sampling provides the researcher with speed and convenience [14]. In interviews, volunteering and availability are taken as basis. The professional experience of the participants who accept the interview varies between 4-15 years. Interviews with the participating faculty members were recorded on a voice recorder with the permission of the participants. Interviews were held in the offices of the engineering and architecture faculties of the participants and the duration of the interview was limited to 15-30 minutes.



## 2.1 Data Analysis

Data analysis includes the editing, structuring and interpretation of aggregated data [23]. In the analysis of semi-structured interview data, content analysis (thematic analysis) method was used. Content analysis is used to reveal the underlying concepts of data and the relationship between these concepts [14], [6]. The interviews recorded in the voice recorder were written text by the researcher. The texts written in the manuscripts were checked by two academicians from the related field and the reliability of the texts written in this article was ensured. Transcripts are coded by decoding the word sentence. The answers to each of the open three questions were derived from those related to the research questions [6]. Codes are also gathered under certain themes. Themes were formed by considering the purpose of the study and the problem question. The themes were controlled by three field experts and a consensus was reached and finalized. In order to calculate the reliability of the study, the reliability method proposed by Miles and Huberman [15] was used. The subjects which have consensus and disagreement” for the codes and themes were determined by both the researcher and the experts were discussed and necessary arrangements were made.

## 3 Findings

In this section, the findings from the analysis of the data obtained from the interviews carried out in order to reveal the opinions of the faculty members of the engineering and architecture faculties on the use of educational computer games and simulations are presented. Content analysis results about the opinions and perceptions of the instructors of engineering and architecture faculties using digital games and simulations in their teaching process were gathered under the themes and presented with direct quotations. The lecturers who are interviewed were the academic staff such as assistant professor, associate professor and professor. Gender distributions of the interviewees were two women and nine men. The age range of the sample group ranged from 32 to 50 years and the professional experience varied between 2 and 15 years. The names of the faculty members were kept confidential and K-1, K-2, ... K-11 were coded.

**Table 1.** Themes

Themes
The reasons of not using the instructional computer games/simulation
The role of computer games/simulations in engineering education
Attitudes of faculty members towards computer games/simulations
Strengths of computer games/simulations
Limitations of computer games/simulations

As a result of the data analysis; six themes were created. These themes are the reasons engineering academic staff utilize educational computer games and simulations the role of educational computer games and simulations in engineering education, the attitudes towards educational computer games and simulations, the strengths of

educational computer games and simulations, the weaknesses of educational computer games and simulations and necessary conditions to educational computer games and simulations in engineering courses. Table 1 lists the themes that were created based on the content analysis.

**The reasons of not using the instructional computer games/simulations.** Engineering faculty members reported several reasons why they are not facilitating educational computer games and simulations in their instruction: One of the most reported reason was there are a few game and simulations available in Turkish language. The other reason was they are not aware of current available simulations and games that can be utilize in engineering education. Furthermore, there are limited number of available software developers to develop educational game and simulation. There is a lack of educational games and simulations that can be fit to the engineering curriculum. The main reasons reported are: shortage of game programmers, and educational game that fits to the curriculum, heavy work load of academic personnel, inadequate infrastructure, and shortage of exemplary lecture that games utilized in engineering education. Lecturers in engineering education have little knowledge about the methods that game and simulation can be facilitated. Furthermore, there is also lack of gaming culture among the faculty members.

**The Role of Computer Games/Simulations in Engineering Education.** Lecturers reported that educational simulations and games can be utilized for the following conditions: teaching abstract and complex concepts, to increase students' motivation and as an alternative teaching method. Participant K-5 reported that *"I believe that simulations and games are useful tools for students. They may help students to demonstrate their skills in the classroom and help them to come up with some new ideas"*.

**Attitudes of Faculty Members towards Computer Games/Simulations.** All of the faculty members interviewed indicated that educational computer games were seen as a useful teaching and learning tool in engineering education. However, they emphasized that educational computer games can be a useful teaching tool after their contents are prepared appropriately. In this regard, participant K-10 stated that *"I think that simulations will be more useful in practice rather than in theory"*.

**Strengths of Computer Games/Simulations.** In the analysis of the data, the strengths of educational games and simulations are: Having visual elements, the potential of motivating students, having an attention drawing feature, repeated use of simulations and games. Simulations and games can be used as a personalized learning tool. They can be adopted student's age and learning pace. For example, participant K-3 reported that *"the strongest part of simulations and games is that students are learning while having fun"*.

**Limitations of Computer Games/Simulations.** In the analysis of the data obtained from the study, faculty of engineering faculty expressed their opinions about the disadvantages of using computer games in education as well as their advantages. Reported disadvantages are: lack of seriousness, experiencing classroom management problems, insufficient connection between game and theory, abuse of students, insufficient curriculum, poor quality, misinterpretation by students, and addiction. For instance, participant K-2 reported that *"students learn by seeing. At this point, games*

*and computers can create a good learning environment. But the quality of the games is very important. The curriculum should be inclusive. Otherwise, it may be very time-consuming for its benefit”.*

#### 4 Discussions & Conclusions

The purpose of this research was to investigate engineering faculty members' views on the use of educational computer games and simulations in engineering education. The analysis of the data revealed that academic staffs of engineering and architecture faculties have positive approach to the use educational computer games and simulations in their courses; however they could not be able to employ the games in their class due to deficiencies of the games appropriate for the curriculum and lack of games in Turkish. Furthermore, using educational computer games and simulations in the engineering courses may improve the quality of instruction, motivate students and make courses more enjoyable according to academic staff views Furthermore, faculty members raise their concerns about classroom management and the possibility of being addicted to games when employing games and simulations in their lectures. According to the analyzed data about the use of computer based educational games in engineering education, facilitating games in engineering instruction could improve the quality of engineering education, motivate students, and allow to raise well-educated engineering students to the industry based on the views of the engineering and architecture faculty staffs. The engineering and architecture faculty academic staff generally are positive to use educational computer games in their courses. However there is a need for the games appropriate for the engineering curriculum. Furthermore, lack of Turkish games in in the market, it is almost impossible to find and integrate educational computer games in engineering instruction in Turkey. Therefore policy makers and decision takers should support initiatives to develop Turkish language learning games. Most of the faculty members are agree that educational game and simulations have the potential to motivate students. Therefore, in order to encourage faculty members to use educational games and educational computer games and simulations in engineering education, initiatives to develop educational games and simulation should be supported by policy makers.

#### References

1. Akgül, A., Uçar, M.K., Öztürk, M.M., Ekşi, Z.: Mühendislik eğitiminin iyileştirilmesine yönelik öneriler, geleceğin mühendisleri ve işgücü analizi. Süleyman Demirel Üniversitesi Fen Bilimleri Enstitüsü Dergisi. **17**(1), 14–18 (2013)
2. Banks, J., Carson, J.S.: Discrete-event system simulation. Prentice-Hall, Englewood Cliffs (1984)
3. Barab, S.A., Gresalfi, M., Ingram-Goble, A.: Transformational Play: Using Games to Position Person, Content, and Context. Educational Researcher. **39**(7), 525–536 (2010). doi:10.3102/0013189X10386593
4. Bayırtepe, E., Tüzün, H.: Oyun-tabanlı öğrenme ortamlarının öğrencilerin bilgisayar dersindeki başarıları ve öz-yeterlik algıları üzerine etkileri. Hacettepe Üniversitesi Eğitim Fakültesi Dergisi. **33**, 41–54 (2007)

5. Boyle, E., Connolly, T.M., Hainey, T.: The role of psychology in understanding the impact of computer games. *Entertainment Computing*. **2**(2), 69–74 (2011). doi:10.1016/j.entcom.2010.12.002
6. Creswell, J.W.: *Research design: Qualitative, quantitative, and mixed methods approaches*. Sage Publications, Thousand Oaks (2014)
7. Deterding, S.: Gamification: designing for motivation. *Interactions*. **19**(4), 14–17 (2012). doi:10.1145/2212877.2212883
8. Duffy, T.M.: Cognitive perspectives in psychology. In: David H. Jonassen (ed.) *Handbook of Research for Educational Communications and Technology*. Simon & Schuster, New York (1996)
9. Gee, J.P.: *What Video Games Have to Teach Us about Learning and Literacy*. Palgrave/Macmillan, New York (2003)
10. Gençoğlu, M.T., Cebeci, M.: Türkiye’de mühendislik eğitimi ve öneriler. Presented at the Mühendislik Mimarlık Eğitimi Sempozyumu, İstanbul, pp. 73–80 (1999)
11. Kapp, K.M.: *The Gamification of Learning and Instruction: Game-based Methods and Strategies for Training and Education*. Pfeiffer & Company, San Diego (2012)
12. Kula, A., Erdem, M.: Öğretimsel bilgisayar oyunlarının temel aritmetik işlem becerilerinin gelişmesine etkisi (The effect of educational computer games on the development of basic arithmetical operation skills). *Hacettepe University Journal of Education Faculty*. **29**, 127–136 (2005)
13. Lopez-Morteo, G., López, G.: Computer support for learning mathematics: A learning environment based on recreational learning objects. *Computers & Education*. **48**(4), 618–641 (2007). doi:10.1016/j.compedu.2005.04.014
14. Marshall, C., Rossman, G.B.: *Designing qualitative research*, 3rd ed. Sage Publications, Thousand Oaks (1999)
15. Miles, M.B., Huberman, A.M.: *Qualitative data analysis: an expanded sourcebook*. Sage Publications, Thousand Oaks (1994)
16. Prensky, M.: Listen to the Natives. *Educational Leadership*. **63**, 20–23 (2006)
17. Przybylski, A.K., Rigby, C.S., Ryan, R.M.: A motivational model of video game engagement. *Review of General Psychology*. **14**(2), 154–166 (2010). doi:10.1037/a0019440
18. Rieber, L.P., Noah, D.: Games, simulations, and visual metaphors in education: antagonism between enjoyment and learning. *Educational Media International*. **45**(2), 77–92 (2008). doi:10.1080/09523980802107096
19. Sharma, R., Ed, B., Phil, M.: Computer assisted learning – A study. *International Journal of Advanced Research in Education & Technology*. **4**(2), 102–105 (2017)
20. de A. Souza, M.R., Veado, L., Moreira, R.T., Figueiredo, E., Costa, H.: A systematic mapping study on game-related methods for software engineering education. *Information and Software Technology*. **95**, 201–218 (2018). doi:10.1016/j.infsof.2017.09.014
21. Squire, K.D.: Video Games and Education: Designing Learning Systems for an Interactive Age. *Educational Technology*. **48**(2), 17–26 (2008)
22. Winn, W.: Cognitive perspectives in psychology. In: Jonassen, D.H. (ed.) *Handbook of Research for Educational Communications and Technology*. Simon & Schuster, New York (1996)
23. Yıldırım, A., Şimşek, H.: *Sosyal bilimlerde nitel araştırma yöntemleri*. Seçkin, Ankara (2006)

# Augmented Reality in Training Engineering Students: Teaching Methods

Yuliia Yechkalo<sup>[0000-0002-0164-8365]</sup>, Viktoriia Tkachuk<sup>[0000-0002-5879-5147]</sup>,  
Tetiana Hrunтова<sup>[0000-0001-6775-6361]</sup>, Dmytro Brovko<sup>[0000-0001-9108-3857]</sup> and  
Vitaliy Tron<sup>[0000-0002-6149-5794]</sup>

Kryvyi Rih National University, 11, Vitalii Matusevych St., Kryvyi Rih, 50027, Ukraine  
{uliaechk, viktoriya.tkachuk, tatianagru, ndhknu}@gmail.com,  
vtron@ukr.net

**Abstract.** *The research aim.* The research is intended to theoretically substantiate, develop and test methods of applying augmented reality to training future engineers. *The research tasks* include adaptation of augmented reality tools to apply them to laboratory classes while training future engineers; visualization of theoretical models of physical phenomena and processes using augmented reality tools; theoretical substantiation and development of methods of applying augmented reality to training future engineers. *The research object* is training future engineers at engineering universities. *The research subject* is methods of applying augmented reality to training future engineers. *The research results* are the following. There are analyzed national and foreign researches into issues of applying augmented reality to training future engineers at engineering universities. The augmented reality tools (HP Reveal) is adapted to be used in laboratory classes in physics while training future engineers. There are created augmented reality objects in the form of educational videos in which the structure of laboratory machines and procedures of working with them are explained. Methods of applying augmented reality to training future engineers at engineering universities are developed.

**Keywords:** Augmented Reality, Training of Future Engineers, Laboratory Works.

## 1 Introduction

### 1.1 Problem statement

Training of future engineers at engineering universities is aimed at forming a competent specialist capable of working under conditions of escalating information flows. Successful solution of this task depends on a student's acquired skills to find, process, understand and use information. Sometimes, students find it difficult to comprehend scientific notions and laws as, in case of traditional training techniques, this material is presented in an abstract form which is difficult to understand. It results into theoretical models not consistent with real-life phenomena and processes.

The augmented reality (AR) technology is one of the modern training means reflecting theoretical notions through visual 2D/3D objects, thus facilitating understanding of abstract notions and models by students.

## 1.2 Analysis of the latest researches

The authors [9; 15] use augmented reality as a means of arranging students' group and solo work while studying electric machines. This provides an opportunity of arranging interactive training and performing laboratory works without a teacher's assistance. AR tools presented in the research create a link between theoretical material and laboratory works. In designing installations and machines, application of AR tools makes students' training motivating and comfortable as they are available and easy to use.

In [13], D. N. Phon, M. B. Ali and N. D. Halim treat augmented reality as a new technology applicable to implementation of innovative teaching-learning methods. Application of AR methods enhances educational results, yet the principle driver implies treating AR design as a support of the training activity. The researchers [16; 18] think that AR provides new opportunities of developing the training environment that enables students to interact with each other and the training content at the same time. It causes deeper comprehension of educational information and enhances students' motivation.

C. Onime, O. Abiona shows a conceptual reality-virtuality relationship between hands-on, remote and virtual laboratories. The hands-on physical laboratories would be at the Realism end, remote laboratories are in the mixed reality zone and virtual laboratories are at the other extreme. Without any visible view of the apparatus, the user interfaces of most remote laboratories are typically computer-generated environments with the insertion of real data taken from the remote apparatus, which is consistent with an augmented virtuality environment [10, p. 70].

In [11], there are developed methods of training future engineers using AR technologies to present educational materials on engineering subjects for theoretical and laboratory training in an interactive form. The authors' goal is to reduce expenditures by introducing AR technologies while conducting an experiment.

The recent researches into augmented, virtual (VR) and mixed realities developed by the world's largest electronics producers were presented at the conference [5]. Both researchers and practitioners were able to improve their skills of mastering up-to-date AR and VR technologies during courses and seminars conducted at the conference.

A. Striuk, M. Rassovytska and S. Shokaliuk substantiated efficiency of applying the AR app Blipper to professional and practical training of future engineers [17]. In [20], we developed theoretical and methodological foundations of AR application to training students with specific educational needs. Ukrainian researchers developed some components of the training and methodological complex for designing VR an AR systems for future Informatics teachers.

However, currently, there are some issues understudied in Ukraine, namely: adaptation of AR tools to be used in laboratory classes while training future engineers; provision of visualization of theoretical models of physical phenomena and processes by modern ICT tools; application of AR technology to forming future engineers'

competences.

### **1.3 Research aim**

The research is aimed at theoretical substantiation, development and experimental examination of the methods of applying AR to training future engineers.

## **2 Main material presentation**

### **2.1 Using ICT in laboratory works**

The present-day educational system emphasizes training which results in acquired knowledge and skills necessary for professional and research activity. Engineering universities focus their attention on developing research competences in laboratory classes. These classes are noted for application of specific tools and devices requiring mastering specific knowledge and skills by students [21]. A laboratory class that envisages a student's independent experimenting is much more significant in its scale than any other form of class organization as it boosts research competences required for his/her further engineering career.

Ya. Ya. Boliubash distinguishes the following stages in the structure of modern laboratory classes: 1) conducting initial control of students' preparedness to perform a laboratory work; 2) doing relative training tasks; 3) preparing an individual report; 4) teachers' assessing students' work results [4]. In laboratory classes, students follow the instruction that can be considered a basic information source. According to Yu. O. Zhuk, this puts forward some requirements to the content and structure of an instruction. The researcher indicates that the description that is too detailed splits students' attention and makes them master too much information that can cause some errors and inefficient use of the training time [22].

First-year students' questioning conducted by the research author [12] reveals that most students have difficulties during laboratory classes including: 1) inability to apply theoretical knowledge to solving definite experimental problems; 2) underdeveloped skills of experimenting; 3) inability to substantiate experiment results by means of available theoretical knowledge; 4) failure to understand professional direction of the work to be done; 5) difficulties associated with reproduction of the material mastered independently; 6) students' reluctance while performing a work; 7) absence of a teacher's due control of laboratory work results.

Application of modern information technologies can be one of solutions of described problems [1; 3; 14]. The experience described in [22] indicates that visualization of information by ICT tools greatly enhances its perception. To ensure motivation of the training activity and make a laboratory class effective, we use the AR technology.

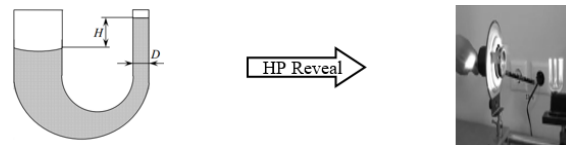
R.T. Azuma defines augmented reality as a system combining virtual objects and reality, interacting on-line and operating in 3D. AR cannot create an entirely virtual environment, yet, it involves both virtual and real-world elements by adding virtual objects changed as a result of a user's actions to his/her surroundings [2]. Thus, AR

provides a modern solution of the problem of encouraging future engineers to conduct their own researches and experiments.

## 2.2 Methods of using augmented reality in laboratory classes

While elaborating methods of applying augmented reality to training future engineers, we analyzed a set of software tools of training support which are widely used as educational sources, namely: Amazon Sumerian, AR Flashcards Space Lite, AR-3D Science, Augment, Blippar, Chromville, Elements 4D, HP Reveal, Layar, Magicplan, Quiver, Google Lens. To create AR objects, we chose the HP Reveal platform as the easiest to adapt to educational needs and available [6]. AR objects are treated as a result of adding virtual objects to real-life markers (video instructions to perform laboratory works) that are perceived as real objects. Schematic drawings (schemes) of laboratory machines can be such markers [8] as they enable students to get ready to a laboratory work independently and efficiently.

AR tools are used in laboratory classes according to the BYOD (Bring Your Own Device) approach: students use their own mobile devices to recognize markers. After pointing the camera of a mobile device at the scheme (marker), there appears a video on the screen in which a teacher demonstrates a laboratory machine and its major elements, comments on the experiment conduction and highlights its peculiarities [7]. Thus, AR objects are supplementary to printed instructions. The result is visualized instructions to conduct laboratory works (Fig. 1).



**Fig. 1.** Visualization of the instruction for the laboratory work “Determination of the liquid tension ratio by the height of its raise in the capillary tube”

The method of applying augmented reality at laboratory classes envisages the following steps: 1) installing the mobile app HP Reveal (Fig. 2); 2) opening and registering (Fig. 3–Fig. 4); 3) searching by the #tag #physicslab (Fig. 5); 4) subsequent to the search results, choosing a laboratory work, for example, mechanics\_lab\_2\_1 (Fig. 6); 5) in the instruction of the laboratory work, finding the scheme – the general view of the laboratory machine. This scheme is a marker identified by the AR tools; 6) when pointing the mobile device at the picture-marker, HP Reveal scans it (Fig. 7). There appears a video in which a teacher shows a laboratory machine, its basic components and comments on conducting the experiment (Fig. 8); 7) watching an educational video, paying attention to the structure of a machine and procedures of working with it; 8) addressing a teacher if any questions arise.

It should be noted that AR application in laboratory physics classes is an efficient method of engaging students into the training process. It is easier for students to understand abstract theoretical models of physical phenomena through their



visualization by using AR tools.

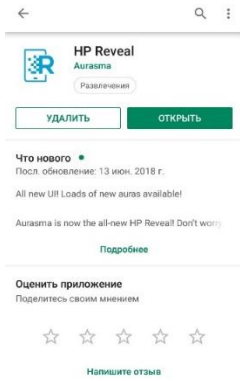


Fig. 2. Install the HP Reveal



Fig. 3. Register the HP Reveal



Fig. 4. Hashtag #physicslab



Fig. 5. Search for mechanics\_lab\_2\_1



Fig. 6. HP Reveal scans

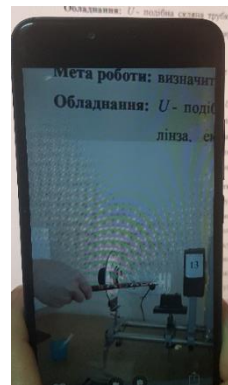


Fig. 7. Educational video

### 3 Results of experimental examination of the suggested methods

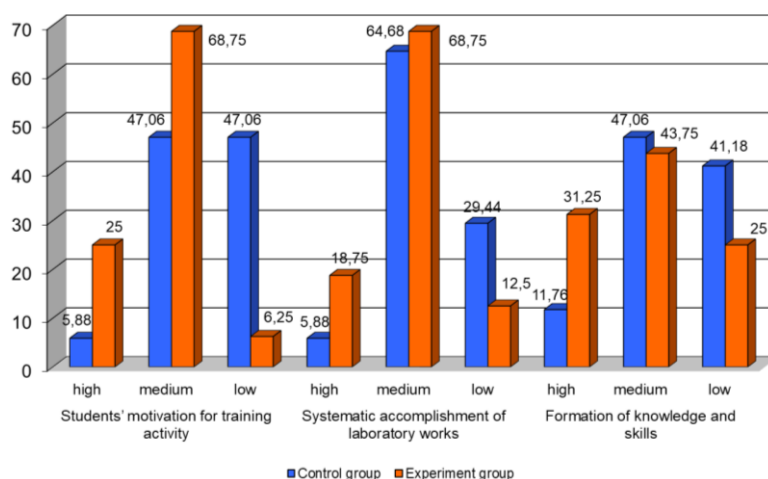
To examine the method, we determine criteria of efficiency of applying augmented reality to training future engineers, their indices and research methods (Table 1).

The pedagogical experiment was conducted at Kryvyi Rih National University during the first term of 2018-2019. First-year students of the speciality Software Engineering were engaged in the experiment comprising 16 students of the experiment group and 17 students of the control group.

The generalized experiment results consistent with the criteria, indices and levels of their formation in the control and experiment groups are given in Fig. 8.

**Table 1.** Criteria of efficiency of applying augmented reality to training future engineers

Criterion of efficiency of applying augmented reality	Index of efficiency of applying augmented reality	Levels of formation	Research methods
Students' motivation for training activity	Availability of students' desire to study, perform complicated tasks; understanding of significance of studies	High; medium; low	Questionnaire "Motivation for training activity", questionnaire "Augmented reality in laboratory physics classes"
Systematic accomplishment of laboratory works	Timely accomplishment of laboratory works; students' active participation in class	High; medium; low	Results of accomplishment of timely laboratory works
Formation of knowledge and skills	Availability of students' knowledge of the subject; a skill to independently accomplish tasks; objective assessment of students' own results	High; medium; low	Module test in physics



**Fig. 8.** Generalized results of the experiment

According to the criterion "Students' motivation for training activity", the number of students of the experiment group with high and medium motivation is larger than that of the control group by 40.81%.

The criteria "Systematic accomplishment of laboratory works" and "Formation of knowledge and skills" reveal the number of students of the experiment group with high and medium motivation which is larger than that of the control group by 16%.

After generalizing the results of the pedagogical experiment, we can conclude that the developed methods of applying augmented reality to training future engineers in laboratory classes in physics are quite efficient, especially in terms of raising students' motivation for the training process.

## 4 Conclusions

While conducting a research into application of augmented reality to training future engineers at engineering universities, we obtained the following results:

1. there are analyzed national and foreign researches into issues of applying augmented reality to training future engineers at engineering universities;
2. the augmented reality tools (HP Reveal) is adapted to be used in laboratory classes in physics while training future engineers and there are created AR objects in the form of educational videos which explain the structure of laboratory machines and procedures of working with them;
3. methods of applying augmented reality to training future engineers at engineering universities are developed;
4. efficiency of the elaborated methods is examined by experiment and proven.

## References

1. Akcayir, M., Akcayir, G.: Advantages and challenges associated with augmented reality for education: A systematic review of the literature. *Educational Research Review*. **20**, 1–11 (2017). doi:10.1016/j.edurev.2016.11.002
2. Azuma, R.T.: Survey of Augmented Reality. *PRESENCE: Virtual and Augmented Reality*. **6**(4), 355–385 (1997). doi:10.1162/pres.1997.6.4.355
3. Bakum, Z., Tkachuk, V.: Mining engineers training in context of innovative system of Ukraine. *Metallurgical and Mining Industry*. **5**, 30–35 (2014)
4. Boliubash, Ya.: Orhanizatsiia navchalnoho protsesu u vyshchych zakladakh osvity (Organization of educational process in universities). Kompas, Kyiv (1997)
5. Course preview: choose from 72 courses and workshops. SPIE Photonics West. <http://spie.org/Documents/Courses/PW19-Course-Preview-Ir.pdf> (2018). Accessed 21 Mar 2019
6. HP Reveal. <https://www.hpreveal.com>. (2018). Accessed 20 Dec 2018
7. Hrunтова, T.V., Yechkalo, Yu.V., Striuk, A.M., Pikilnyak, A.V.: Augmented Reality Tools in Physics Training at Higher Technical Educational Institutions. In: Kiv, A.E., Soloviev, V.N. (eds.) *Proc. of the 1st International Workshop on Augmented Reality in Education (AREdu 2018)*, Kryvyi Rih, Ukraine, October 2, 2018. CEUR Workshop Proceedings, vol. 2257, pp. 33–40. <http://ceur-ws.org/Vol-2257/paper04.pdf> (2018). Accessed 21 Mar 2019
8. Hrunтова, T.V., Perevertailo, O.I.: Fizyka. Metodichni vkazivky do laboratornoho praktykumu. Chastyna I «Klasychna mekhanika. Molekuliarna fizyka i termodynamika» (Physics. Methodical instructions for a laboratory workshop. Part I «Classical mechanics. Molecular physics and thermodynamics»). Kryvyi Rih (2014)
9. Martín-Gutiérrez, J., Fabiani, P., Benesova, W., Meneses, M.D., Mora, C.E.: Augmented reality to promote collaborative and autonomous learning in higher education. *Computers in Human Behavior*. **51**(Part B October), 752–761 (2015). doi:10.1016/j.chb.2014.11.093
10. Onime, C., Abiona, O.: 3D Mobile Augmented Reality Interface for Laboratory Experiments. *International Journal of Communications, Network and System Sciences*. **9**(4), 67–76 (2016). doi:10.4236/ijcns.2016.94006
11. Onime, C., Uhomobhi, J., Zennaro, M.: Demonstration of a low cost implementation of an existing hands-on laboratory experiment in electronic engineering. In: 2014 11th

- International Conference on Remote Engineering and Virtual Instrumentation (REV), 26-28 Feb. 2014, Porto, Portugal, pp. 195–197 (2014). doi:10.1109/REV.2014.6784253
12. Petrenko V.V.: Laboratorni zaniattia yak orhanizatsiina forma eksperymentalnoi pidhotovky studentiv-pershokursnykiv biolohichnoho fakultetu (Laboratory classes as an organizational form of experimental training of freshmen students of the biological faculty). *Bull. Zaporizhzhya National University*. 1, 208–211 (2008)
  13. Phon, D.N.E., Ali, M.B., Halim, N.D.A.: Collaborative Augmented Reality in Education: A Review. In: 2014 International Conference on Teaching and Learning in Computing and Engineering, 11-13 April 2014, Kuching, Malaysia, pp. 78–83 (2014). doi:10.1109/LaTiCE.2014.23
  14. Popel, M.V., Shyshkina, M.P.: The Cloud Technologies and Augmented Reality: the Prospects of Use. In: Kiv, A.E., Soloviev, V.N. (eds.) *Proc. of the 1st International Workshop on Augmented Reality in Education (AREdu 2018)*, Kryvyi Rih, Ukraine, October 2, 2018. *CEUR Workshop Proceedings*, vol. 2257, pp. 232–236. <http://ceur-ws.org/Vol-2257/paper23.pdf> (2018). Accessed 21 Mar 2019
  15. Restivo, M.T., Chouzal, F., Rodrigues, J., Menezes, P., Patrão, B., Lopes, J.B.: Augmented Reality in Electrical Fundamentals. *International Journal of Online and Biomedical Engineering*. **10**(6), 68–72 (2014)
  16. Rizov, T., Rizova, E.: Augmented reality as a teaching tool in higher education. *International Journal of Cognitive Research in Science, Engineering and Education*. **3**(1), 7–16 (2015)
  17. Striuk, A., Rassovytska M., Shokaliuk S.: Using Blippar Augmented Reality Browser in the Practical Training of Mechanical Engineers. In: Ermolayev, V., Suárez-Figueroa, M. C., Yakovyna, V., Kharchenko, V., Kobets, V., Kravtsov, H., Peschanenko, V., Prytula, Ya., Nikitchenko, M., and Spivakovsky, A. (eds.) *ICT in Education, Research and Industrial Applications. Proc. 14 th Int. Conf. ICTERI 2018. Volume II: Workshops*. Kyiv, Ukraine, May 14-17, 2018. *CEUR Workshop Proceedings*, vol. 2104, pp. 412–419. [http://ceur-ws.org/Vol-2104/paper\\_223.pdf](http://ceur-ws.org/Vol-2104/paper_223.pdf) (2018). Accessed 21 Mar 2019
  18. Sural, I.: Augmented Reality Experience: Initial Perceptions of Higher Education Students. *International Journal of Instruction*. **11**(4), 565–576 (2018)
  19. Syrovatskyi, O.V., Semerikov, S.O., Modlo, Ye.O., Yechkalo, Yu.V., Zelinska, S.O.: Augmented reality software design for educational purposes. In: Kiv, A.E., Semerikov, S.O., Soloviev, V.N., Striuk, A.M. (eds.) *Proc. of the 1<sup>st</sup> Student Workshop on Computer Science & Software Engineering (CS&SE@SW 2018)*, Kryvyi Rih, Ukraine, November 30, 2018. *CEUR Workshop Proceedings*, vol. 2292, pp. 193–225. <http://ceur-ws.org/Vol-2292/paper20.pdf> (2018). Accessed 21 Mar 2019
  20. Tkachuk, V.V., Yechkalo, Yu.V., Markova, O.M.: Augmented reality in education of students with special educational needs. In: Semerikov, S.O., Shyshkina, M.P. (eds.) *Cloud Technologies in Education. Proc. of the 5th Workshop CTE 2017*, Kryvyi Rih, Ukraine, April 28, 2017, pp. 66–71. *CEUR Workshop Proceedings*, vol. 2168, pp. 66–71. <http://ceur-ws.org/Vol-2168/paper9.pdf> (2018). Accessed 21 Mar 2019
  21. Zhuk, Yu.O.: Laboratorna robota z fizyky ta problema instruktzii do nei (Laboratory work on physics and problem of instruction to such work). *Fizyka ta astronomiia v Shkoli*. 1, 17–19 (1999)
  22. Zhuk, Yu.O.: Teoretyko-metodychni zasady orhanizatsii navchalnoi diialnosti starshoklasnykiv v umovakh kompiuterno orientovanoho seredovyscha navchannia (Theoretical and methodological principles of organization of educational activity of senior pupils in the conditions of computer-oriented learning environment). *Pedahohichna dumka*, Kyiv (2017)

# Designing of Virtual Cloud Labs for the Learning Cisco CyberSecurity Operations Course

Nadiia Balyk<sup>[0000-0002-3121-7005]</sup>, Yaroslav Vasylenko<sup>[0000-0002-2954-9692]</sup>,  
Vasyl Oleksiuk<sup>[0000-0003-2206-8447]</sup> and Galina Shmyger<sup>[0000-0003-1578-0700]</sup>

Ternopil Volodymyr Hnatiuk National Pedagogical University  
2, M. Kryvonosa St., Ternopil, 46027, Ukraine

{nadbala, yava, oleksyuk, shmyger}@fizmat.tnpu.edu.ua

**Abstract.** The article is devoted to the study of the problem of the cybersecurity basics teaching. The training of the ICT-specialties students using the course “CCNA Cyber Operations” of the network academy Cisco is considered. At present, many universities have similar academies, while others can open them. On the basis of free software platforms Apache CloudStack and EVE-NG Community authors designed and implemented a virtual cloud laboratory. It operates according to the “IaaS” model. Thanks to the technology of embedded virtualization, the work of many virtual machines, storing of their status, traffic analysis and visualization of network topologies are maintained.

The article describes the experience of teaching students of the specialty “Pedagogical education. ICT” in the course “CCNA Cyber Operations” with the use of virtual cloud laboratories. The authors have been conducted a survey of students who studied at the course. Its purpose was to determine how much they satisfied were with the course. Statistical processing of the results was performed on the basis of the Rasch model using the software MiniSteps.

**Keywords:** ICT-competence, virtual cloud lab, Apache CloudStack, EVE-NG Community, computer science trainee teachers, Rasch model.

## 1 Introduction

Today, the development of computer networks provides almost universal access to information resources. Along with the positive, there are negative consequences – interference with private life, theft or destruction of the personal or corporate data. Many people are unaware that when browsing Internet sites, it is possible to process and store their personal data and transactions not only by web page developers, but also by outsiders. Massive data collection through social networks, profiling of the viewing of information resources creates the effect of the “digital shadow” of a person [14].

Solving the problem is possible provided the development of information security competencies. At present, many universities in Ukraine are preparing specialists in the field of cybersecurity. However, this process must be continuous and start at school.

In this context, the teaching of informatics teachers on the basics of cybersecurity is an important problem. One way to solve this problem is to study open courses by students. Their advantages are as follows: the opportunity to study at a convenient time; the ability to compare teaching styles and materials of different courses; the experience in discussing and peer assessment; improving the skills of listening, reading and writing English (or other); reflection of their own pedagogical activity in the light of new ideas, the digital creativity and collaboration with other participants [9].

Cisco offers similar courses within Cisco Network Academy. Although these courses do not fully correspond to the ideology of the MOOC, Cisco Network Academy can be organized at virtually any university. Cisco Networking Academy, a Cisco Corporate Social Responsibility Program, is an IT skills and career building program available to educational institutions and individuals worldwide.

**The goal of this article** is to design the virtual cloud labs for formation teachers' competences in cybersecurity and to research the efficiency of such labs..

## 2 Presentation of the main results

As the experience of a secondary school shows, a teacher of informatics is the leading ICT specialist [1]. In the context of providing information security, he must be able to balance the advantages and disadvantages of using network technologies in the learning process. Having analyzed the available free courses, we chose CCNA Cyber Operations [4] as a basic course for formation teachers' cybersecurity competences. By the end of this course, the students will be able to:

- Install virtual machines to analyzing cybersecurity threat events.
- Explain the role of the Cybersecurity Operations Analyst in the enterprise.
- Explain the Windows and Linux OS features to support cybersecurity analyses.
- Analyze the operation of network protocols and services.
- Classify the various types of network attacks and identify network security alerts.
- Use network monitoring tools to identify attacks against network protocols.
- Use various methods to prevent malicious access to computer networks.
- Apply incident response models to manage network security incidents.

The course contains the following chapters: Cybersecurity and the Security Operation Center, Windows OS, Linux OS, Network Protocol and Services; Network Infrastructure, Principles of Network Security, Network Attacks: A Deep Look, Protection the network, Cryptography and the Public Key Infrastructure, Endpoint Security and Analysis, Security Monitoring, Intrusion Data Analysis, Incident.

Each chapter of this course contains terms and concepts review, quiz, labs and exam. In the process of teaching the course, we met with the problem of organizing laboratory works. Cisco Network Academy offers to run them on virtual student machines. This approach is justified, but it limits the universal and everywhere access of students to study. The use of separate virtual machines does not ensure the cooperation of students between themselves and with the teacher.

An effective way to overcome these limitations is to use the cloud technologies. The authors [11] note that the development of cloud computing technologies, adaptive information and communication networks services, virtual and mobile learning facilities are the important step towards solving the problems of accessibility and quality of training. Application of cloud technologies in professional activities should correspond the requirements of fundamentalization of learning through the inclusion in the content general both the theoretical and the technological provisions, with demonstration of them on the concrete examples [6]. M. Shishkina and O. Glazunova distinguishes the following levels of the University Cloud-based Learning and Research Environment: physical, level of the virtualization and virtual resource management, as well as platforms and software levels [5].

We deployed a cloud-based environment according to the IaaS model. In the environment, the public and private cloud platforms are integrated. Since the corporate cloud platforms are widely using the virtualization technology, we see as possible the deployment of virtual training laboratories on their basis.

After analyzing the interpretation of V. Bykov, we note that the virtual laboratory is an information system in which network virtual ICT objects are formed thanks to a special user interface, which is supported by the system software of the network setting. Such objects are an integral part of a logical network infrastructure with a flexible architecture that, according to its structure and time, corresponds to the personality needs of the user [3].

Typically, in a virtual laboratory, information from a subject field is based on some facts, and therefore limited by a set of predicted experiments. Another approach suggests that a pupil or student is able to carry out any experiments, not limited to a previously prepared set of results. It is thanks to the use of the virtualization technology of operating systems, the last approach should be tried to implement in the designed laboratory. Cloud technologies and virtualization technology provide unique opportunities for the learning organization of the Cisco CyberSecurity Operations course.

The designed virtual laboratory was implemented in the cloud-based learning environment of Volodymyr Hnatiuk Ternopil National Pedagogical University. Based on the comparative analysis [8], as the program basis of the laboratory, we have chosen the Apache CloudStack platform. Then we modified the Cloud-based Learning Environment so that students could create virtual networks. This networks should not require changes in the topology of physical networks in the academic cloud. We divided the traffic transmitted between students' virtual computers among 100 VLANs. So each student has an opportunity to store their virtual computers and other devices in their personal or several guest networks.

As Apache CloudStack does not provide tools for visualization of network structure, students often have difficulty in designing and configuring networks in a cloud infrastructure. That fact prompted us to integrate into a virtual cloud laboratory a system that makes it possible to visualize the process of network design. It was vital that such system could work with networks on Apache CloudStack virtual machines. We analyzed relevant publications and compared several platforms – Cisco packet tracer, Graphical Network Simulator (GNS), Unetlab (EVE-NG). Despite the benefits

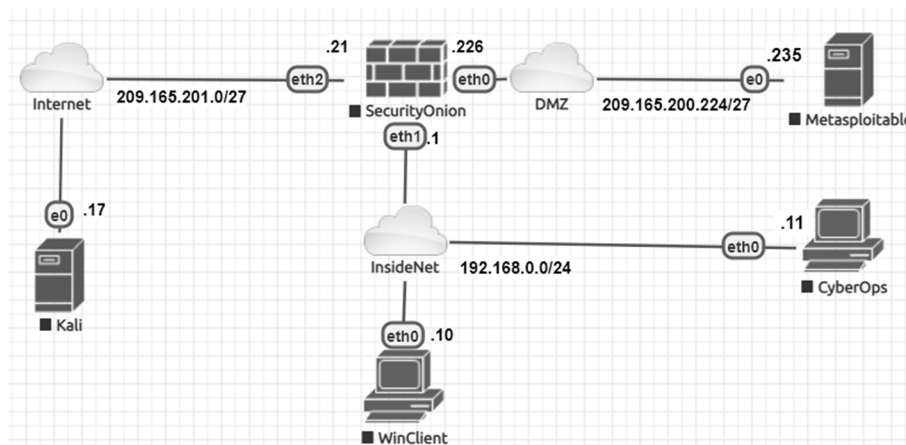
of Cisco packet tracer, it did not provide the performance of all tasks of the laboratory works. Among the platforms of GNS and EVE-NG, we have chosen the last.

Every student's copy of ENE-NG platform is a separate virtual machine in Apache CloudStack cloud. As each node of EVE-NG is itself a virtual machine, hosts integrated in Apache CloudStack infrastructure have to support nested virtualization.

The laboratory works involves the use of such virtual machines: CyberOps WorkStation (based on Arch Linux); Kali Linux; Security Onion (based on Ubuntu Linux); Metasploitable; Windows Client.

The students used a virtual cloud laboratory when performing the laboratory works of following chapters: Windows Operating System, Linux Operating System, Network Protocols and Services, Network Attacks, Intrusion Data Analysis [Ошибка! Источник ссылки не найден.].

A typical topology of the network for the laboratory works is showed on Figure 1.



**Fig. 1.** The network topology for labs

Each of these machines was available in a cloud-based infrastructure. As a result, students could work with virtual machines in the university's local network or through VPN. The course was taught in a mixed methodology. It was dominated by independent distance work of students. The teacher's consultations were carried out at the classroom and online.

After learning the course, students completed the final exam. He contained 60 questions from all the topics of the course, as well as the fragments of laboratory works. 56 students majoring in "Pedagogical education. ICT" passed the exam. Of these, only 24 passed the exam successfully (75% points and more). This indicator can be explained by the fact that the course "Cyber Operations" was studied as optional and did not affect the student's rating at the university.

In addition to the final exam students responded to the questionnaire "CyberOps Course Feedback". Questionnaire questions were formulated according to the principle of the Likert scale (five response categories) and grouped in 5 blocks [10].



### 3 Statistical analysis of research data

To evaluate the efficiency of the designed and deployed cloud-based environment, a model with equally distributed responses of all indicators on the scale of the latent variable was used. This is one of the models of the Rasch's family, which is used in the case of polithomus indicators. The Rasch's model is interpreted as a model of "objective measurements" that do not depend from the respondents and measuring instruments [2].

To measure the complexity of tasks and level of knowledge, the unit of measurement, called logit, is used. In our research, we used the WINSTEPS program (USA). The program is commercial, but its free version called MINISTEP. It allows you to use all the capabilities of WINSTEPS, but has a limit on the number of questions in the test (25) and the number of people (75) [15].

Standardized Residuals in the Rasch's model are modeled for normal distribution. Therefore, significant deviations from the value of "0" for the Mean and the "1" for the Standard Deviation (SD) signal that the primary data do not correspond to the Rasch's model, which should correspond exactly to the normal distribution. In our study, the values Mean = -0.02 and SD = 1.03 are sufficiently satisfactory.

Reliability of the survey scale. The classic indicator of reliability of the survey scale is alpha Kronbach. Professionally designed tests must have an internal consistency of at least 0.90. In our survey, the Cronbach coefficient  $\alpha=0.96$ .

As can be seen from Figure 2, informational and characteristic functions are acceptable for IRT (Item Response Theory) analysis.

**Table 1.** Output table "Summary Statistics" (summary of 56 measured person)

	Total Score	Count	Measure	Model S.E.	INFIT		OUTFIT	
					MNSQ	ZSTD	MNSQ	MNSQ
MEAN	72.1	25.0	-0.20	0.25	1.06	-0.13	1.07	-0.14
SEM	2.9	0	0.18	0.00	0.08	0.29	0.09	0.29
P.SD	21.5	0	1.30	0.03	0.62	2.27	0.65	2.14
S.SD	21.6	0	1.31	0.03	0.63	2.19	0.66	2.16

Person raw score-to-measure correlation = 1.00.

Cronbach Alpha (kr-20) person raw score "test" reliability = 0.96, sem = 4.07.

**Table 2.** Output table "Summary Statistics" (summary of 25 measured item)

	Total Score	Count	Measure	Model S.E.	INFIT		OUTFIT	
					MNSQ	ZSTD	MNSQ	MNSQ
MEAN	161.6	56.0	0.00	0.17	0.98	-1.13	1.07	-0.80
SEM	2.5	0	0.07	0.00	0.17	0.83	0.19	0.88
P.SD	12.2	0	0.34	0.00	0.84	4.08	0.95	4.32
S.SD	12.4	0	0.35	0.00	0.85	4.16	0.97	4.41

Item raw score-to-measure correlation = -1.00

In columns INFIT and OUTFIT Tables 1, 2 specified parameters that characterize the correspondence of the data to Rasch’s model. In the field MNSQ (mean-square statistic) the statistics of the correspondence of the output data to the measuring model are showed, obtained on the base of the average sums of the squares of the deviations of the theoretical values from the empirical ones. The most qualitative and significant (productive) measurements are those for which the MNSQ values lie in the range of 0.5 to 1.5. In the ZSTD field, the standardized MNSQ values are showed (with an average of 0 and a standard deviation of 1). Valid value is  $-2.0 \leq ZSTD \leq +2.0$ . For this survey, the match statistics for the measurements of all items are in these ranges, so they can all be used for further analysis.

Figure [12] shows the distribution of respondents and their judgments on the same interval scale (efficiency of the designed and deployed cloud-based environment). The content and composition of the questions in the survey is satisfactory – this is evident from the second bar graph [6].

**Table 3.** Item Statistics: Measure Order

Entry number	Total Score	Total Count	Measure	Model S.E.	Item
11	135	56	0.75	0.17	CA6
1	147	56	0.41	0.17	CS1
3	149	56	0.35	0.17	CS3
12	151	56	0.29	0.17	CA7
16	151	56	0.29	0.17	CI4
19	154	56	0.21	0.17	CC2
14	155	56	0.18	0.17	CI2
21	156	56	0.15	0.17	CC4
7	157	56	0.13	0.17	CA2
10	159	56	0.07	0.17	CA5
6	160	56	0.04	0.17	CA1
9	160	56	0.04	0.17	CA4
15	160	56	0.04	0.17	CI3
18	160	56	0.04	0.17	CC1
13	161	56	0.02	0.17	CI1
4	162	56	-0.01	0.17	CS4
2	165	56	-0.09	0.17	CS2
17	166	56	-0.12	0.17	CI5
25	168	56	-0.18	0.17	CP4
8	169	56	-0.20	0.17	CA3
5	170	56	-0.23	0.17	CS5
23	172	56	-0.29	0.17	CP2
24	176	56	-0.40	0.17	CP3
22	177	56	-0.43	0.17	CP1
20	200	56	-1.08	0.17	CC3
Mean	161.60	56.00	0.00	0.17	
P.SD	12.20	0.00	0.34	0.00	

By analyzing Table 3 in terms of the distractors included in the poll, the following conclusions can be drawn. Distractors with the lowest estimate of the efficiency of the

proposed medium (Measure = -1.08, Item = CC3) and with the highest estimate of the efficiency (Measure = 0.75, Item = CA6) are not presentational for this study, since on the responses had an impact the factor of randomness and the factor of reluctance of respondents to understand the content of the questions deeply. The rest of the distractors can be divided into three groups according to the degree of influence on the overall efficiency: 1) with a small degree of influence on the overall efficiency (Measure from -0.43 to -0.12, Items = CP1, CP3, CP2, CS5, CA3, CP4, CI5); 2) with a mediocre degree (Measure from -0.09 to 0.07, Items = CS2, CS4, CI1, CC1, CI3, CA4, CA1, CA5); 2) with a large degree of impact on overall efficiency (Measure from 0.13 to 0.41, Items = CA2, CC4, CI2, CC2, CI4, CA7, CS3, CS1). The analysis of these distractors at the content level will allow for the adjustment of the structure, some components in design of virtual cloud labs for the learning Cisco CyberSecurity Operations.

#### 4 Conclusions

Learning the basics of cybersecurity is a topical issue of ICT students training. The course “CCNA Cyber Operations” of Cisco Network Academy provides an opportunity to organize such training. It contains a lot of theoretical materials, quiz tasks, discussion questions, labs, chapters exams and final exam. A virtual cloud laboratory was designed to carry out laboratory works at the course. For this purpose, the Apache CloudStack and EVE-NG Community Edition platforms were used. The virtual cloud laboratory provides the following possibilities: to create the required number of virtual machines; to change the computing power; to simulate the work of real computers and networks; to visualize different network topologies; to keep the state of virtual computers; to work remotely through a virtual private network; to combine separate virtual networks of students into a single network; to help students and control their learning outcomes.

The conducted experimental research and its statistical processing have confirmed by the efficiency of the use of the virtual cloud laboratory. Along with high-quality training materials from the Cisco Network Academy, the students appreciated highly the functional and widespread access to the virtual objects of the cloud lab.

#### References

1. Bilousova, L., Ponomarova H.: The Role of the Information Technologies Teacher in the of Secondary School Pupils Career Guidance to IT-speciality. Professionalism of the Teacher: Theoretical and Methodological Aspects. 4, 157–166. <http://pptma.dn.ua/index.php/en/archive/archive-2016/issue-4-2016/374-the-role-of-the-information-technologies-teacher-in-the-of-secondary-school-pupils-career-guidance-to-it-speciality> (2016). Accessed 26 Mar 2019
2. Bond, T., Fox, C.: Applying the Rasch Model: Fundamental Measurement in the Human Sciences. Routledge, New York. (2007)

3. Bykov V., Shyshkina, M.: Theoretical and Methodological Principles of the Cloud Based University Environment Formation. Theory and practice of social systems management. 2, 30–52. <http://tipus.khpi.edu.ua/article/view/73497> (2016) Accessed 26 Mar 2019
4. CCNA Cyber Ops - Cisco. <https://www.cisco.com/c/en/us/training-events/training-certifications/certifications/associate/ccna-cyber-ops.html> (2019). Accessed 26 Mar 2019.
5. Glazunova, O., Shyshkina, M.: The Concept, Principles of Design and Implementation of the University Cloud-based Learning and Research Environment. In: Ermolayev, V., Suárez-Figueroa, M.C., Yakovyna, V., Kharchenko, V., Kobets, V., Kravtsov, H., Peschanenko, V., Prytula, Ya., Nikitchenko, M., Spivakovsky A. (eds.) Proceedings of the 14th International Conference on ICT in Education, Research and Industrial Applications. Integration, Harmonization and Knowledge Transfer (ICTERI, 2018), Kyiv, Ukraine, 14-17 May 2018, vol. II: Workshops. CEUR Workshop Proceedings. **2104**, 332–347. [http://ceur-ws.org/Vol-2104/paper\\_158.pdf](http://ceur-ws.org/Vol-2104/paper_158.pdf) (2018). Accessed 26 Mar 2019
6. Information and Characteristic functions. [https://docs.google.com/document/d/1L-0hdOwfjSSIub\\_xEIQCbVMqkvHAbBPIXicUMiW-e8o/edit](https://docs.google.com/document/d/1L-0hdOwfjSSIub_xEIQCbVMqkvHAbBPIXicUMiW-e8o/edit) (2019). Accessed 22 May 2019
7. Markova, O., Semerikov, S., Popel, M.: CoCalc as a Learning Tool for Neural Network Simulation in the Special Course “Foundations of Mathematic Informatics”. In: Ermolayev, V., Suárez-Figueroa, M.C., Yakovyna, V., Kharchenko, V., Kobets, V., Kravtsov, H., Peschanenko, V., Prytula, Ya., Nikitchenko, M., Spivakovsky A. (eds.) Proceedings of the 14th International Conference on ICT in Education, Research and Industrial Applications. Integration, Harmonization and Knowledge Transfer (ICTERI, 2018), Kyiv, Ukraine, 14-17 May 2018, vol. II: Workshops. CEUR Workshop Proceedings. **2104**, 338–403. [http://ceur-ws.org/Vol-2104/paper\\_204.pdf](http://ceur-ws.org/Vol-2104/paper_204.pdf) (2018). Accessed 26 Mar 2019
8. Oleksyuk, V.: Designing of university cloud infrastructure based on apache Cloudstack. Information Technologies and Learning Tools. **54**(4), 153–164 (2016). doi:10.33407/itlt.v54i4.1453
9. Panchenko, L.: MOOCs for the Development of the Teacher of the New Ukrainian School. <http://lib.iitta.gov.ua/709942> (2018). Accessed 26 Mar 2019
10. Questionnaire of Cyber Operations Course Feedback. <https://docs.google.com/document/d/1nOeGMi3JgDYdkAt9exJTjLR5YoFIWcdg0Rgo-XKME64/edit> (2019). Accessed 15 May 2019
11. Semerikov, S., Shyshkina, M. (eds.): Cloud Technologies in Education. Proceedings of the Workshop, CTE 2017. CEUR Workshop Proceedings. **2168**. <http://ceur-ws.org/Vol-2168> (2018). Accessed 26 Mar 2019
12. The relationship between the level of efficiency of the designed and deployed cloud-based virtual lab and the indicator variables. <https://docs.google.com/document/d/1vL0C71qNAB11O6aKuJDq5MIT4uPZ114b8K1ysD2JcI8/edit> (2019). Accessed 22 May 2019
13. The topics of work, in the study of which was used virtual cloud laboratory. [https://docs.google.com/document/d/1YUqSJpx93nj\\_X31yeKGzVWNWx9B3PpkKcTri8xH3NOc/edit?usp=sharing](https://docs.google.com/document/d/1YUqSJpx93nj_X31yeKGzVWNWx9B3PpkKcTri8xH3NOc/edit?usp=sharing) (2019). Accessed 15 May 2019
14. van Rooy, D.; Bus, J.: Trust and Privacy in the Future Internet – a Research Perspective. Identity in the Information Society. **3**(2), 397–404 (2010). doi:10.1007/s12394-010-0058-7
15. WINSTEPS & Facets Rasch Software. <http://www.winsteps.com> (2019). Accessed 26 March 2019

# Using the Cloud-oriented Virtual Chemical Laboratory VLab in Teaching the Solution of Experimental Problems in Chemistry of 9th Grade Students

Pavlo Nechypurenko<sup>[0000-0001-5397-6523]</sup>, Tetiana Selivanova<sup>[0000-0003-2635-1055]</sup>  
and Maryna Chernova

Kryvyi Rih State Pedagogical University, 54, Gagarina Ave., Kryvyi Rih, 50086, Ukraine  
acinonyxleo@gmail.com

**Abstract.** The article discusses the importance of the skills of primary school students to solve experimental problems in chemistry and the conditions for the use of virtual chemical laboratories in the process of the formation of these skills. The concept of “experimental chemical problem” was analyzed, classifications were considered, and methodological conditions for using experimental chemical problems in the process of teaching chemistry were described. The essence of the concept of “virtual chemical laboratories” is considered and their main types, advantages and disadvantages that define the methodically reasonable limits of the use of these software products in the process of teaching chemistry, in particular, to support the educational chemical experiment are described. The capabilities of the virtual chemical laboratory VLab to support the process of solving experimental problems in chemistry in grade 9 have been determined. The main advantages and disadvantages of the virtual chemical laboratory VLab on the modeling of chemical processes necessary for the creation of virtual experimental problems in chemistry are analyzed. The features of the virtual chemical laboratory VLab, the essence of its work and the creation of virtual laboratory work in it are described. The results of the study is the development of a set of experimental tasks in chemistry for students in grade 9 on the topic “Solutions” in the cloud-oriented virtual chemical laboratory VLab.

**Keywords:** experimental tasks in chemistry, virtual chemical laboratories, solutions.

## 1 Introduction

Electronic learning tools are widely used in the educational process of teachers from different disciplines, but it is in the chemistry lessons of their use that is perhaps the most appropriate. A chemist should not so much accumulate knowledge as discover something new. Electronic learning tools, in particular clouds oriented virtual chemical laboratories, can bring the process of knowledge of chemical laws to a qualitatively new level: to facilitate the involvement of all participants in the educational process in active search and research activities, self-expression; to ensure the formation of critical

and associative thinking, imagination; promote the development of the ability to argue, analyze data, justify and argue the conclusions.

One of the important means of developing chemical thinking and checking the strength of learning is the experimental tasks in chemistry. However, now this kind of tasks is practically not used in the educational process at school, but it is used at high levels olympiads in chemistry. One of the reasons for this phenomenon is the lack of time for the organization of experimental tasks, the risk associated with possible harm to the health of students, the insufficient provision of schools with chemical reagents and equipment, and the like. Virtually all of the above problems can be solved with the help of appropriate means of information and communication technology (ICT).

That is why the purpose of our work is to determine the capabilities of the virtual chemistry laboratory VLab to ensure the possibility of solving experimental problems in chemistry and developing the appropriate set of virtual computer problems.

To achieve this goal it is necessary to solve the following tasks:

- to analyze the concept of “experimental task in chemistry” and find out the meaning and place of experimental tasks in the school chemistry course;
- analyze the opportunity of using clouds-oriented virtual chemical laboratories in pre-profile training;
- find out the advantages and disadvantages of using the Virtual Lab in the creation and implementation of virtual chemistry labs;
- apply the results of research in practice in the form of creating a set of virtual experimental chemistry problems for students in grade 9.

To solve the tasks set in the work, the following research methods were used:

- analysis of methodological, pedagogical and chemical literature, Internet sources;
- analysis of teachers’ experiences;
- systematization and synthesis;
- modeling of chemical processes in the virtual chemical laboratory Virtual Lab.

## **2 Theoretical foundations of using cloud-oriented virtual chemical laboratories in teaching the solution of experimental problems in chemistry**

### **2.1 Experimental tasks as a means of teaching chemistry**

Chemistry is an experimental science, and that is why a chemical experiment in pupil’s develops a chemical style of thinking – the ability to understand the essence of chemical processes, their significance and how to manage them. The modern pedagogical process should be aimed at the child’s mastering the very techniques, methods, ways of thinking, that is, the student must master the technology of carrying out appropriate mental actions.

From the studies of famous teachers, didactists, psychologists, the formation of learning abilities is a complex process, the essence of which is to create opportunities

for performing work related to learning. In particular, the competence-based approach focuses on the acquisition of skills, experience, and practical application of acquired knowledge in chemistry. Therefore, despite the fact that the content of educational material in chemistry is directed to students mastering practical skills in working with substances, provides for observation and experiment, solving computational and experimental problems, establishing causal relationships, the use of algorithms helps students in solving a number of problems, over time, develop into the ability to solve life problems [15].

Thanks to the educational chemical experiment, students acquire practical experience in obtaining facts and their preliminary synthesis at the level of empirical concepts, concepts and laws. Under such conditions, the chemical experiment performs the function of the method of educational cognition, thanks to which new connections and relationships are formed in the consciousness of the student, personal knowledge is formed. It is because of the educational chemical experiment that the activity approach to teaching chemistry is effectively implemented. But it is impossible to carry out an experiment without first considering the result and not drawing up an action plan. That is why the experimental problem solving as a kind of simulator are offered to students.

The solution of chemical problems is an important aspect of mastering the knowledge of the basics of chemical science. The inclusion of tasks in the educational process allows the following didactic teaching principles to be implemented: 1) ensuring the independence and activity of students; 2) the achievement of the strength of knowledge and skills; 3) implementation of the connection of learning with life; 4) the implementation of polytechnic chemistry training, vocational guidance [21].

The ability to solve problems develops in the process of learning, and this skill can be developed only in one way – to solve problem constantly and systematically.

Algorithmic actions of students in solving chemical problems in most cases is not at all in strict adherence to a specific procedure, guaranteed to lead to the correct result. But the learning algorithm, according to M. M. Savchin, first of all means a certain variability of actions in search of the optimal way to solve the problem [15]. In many cases, this variation in the course of isolation is inherent in experimental chemical problems.

Among the diverse arsenal of methods of teaching chemistry, a special place is occupied by the solution of experimental problems in the classroom and the fulfillment of home experiments by students. Experimental tasks are tasks whose solution is accompanied by experiments. M. S. Pak considers experimental chemical problems as a type of cognitive tasks in chemistry [14, p. 162]. In contrast to laboratory work and practical exercises, students solve experimental tasks on their own without additional instructions from the teacher. All students' work in solving experimental problems is built on an attempt to apply acquired theoretical knowledge and practical skills to solve a specific problem in conditions close to real ones.

In its content, the experimental tasks can be directed to:

- observation and explanation of phenomena;
- preparation of solutions;

- execution of characteristic and qualitative reactions;
- recognition of substances.

You can also give another classification of experimental problems, according to which they are based on the activities of:

- familiarization with the properties of substances;
- determining the qualitative composition of substances;
- separation of mixtures;
- phased conversion of substances;
- determination of the quantitative composition of substances, mixtures
- release of substances from the mixture in its pure form;
- quantitative problems on the laws of conservation of mass of substances and the stability of their composition;
- preparation of solutions of a given concentration and determination of the concentration of an unknown solution [1].

To solve any experimental problem, a certain sequence of actions is characteristic:

1. drawing up an experiment plan (action algorithm), within which it is necessary to determine which specific question should be answered and which experiments should be carried out for this purpose;
2. the implementation of the experimental part;
3. the formulation of conclusions about the possibility of using the obtained experimental data to answer the question posed, and reasonable evidence or refutation of the initial assumptions [8].

Experimental problems in chemistry can be solved by the following methods: analytical-synthetic, hypotheses, and attempts. But mainly experimental problems in chemistry are solved by the analytical-synthetic method.

The use of experimental tasks in the educational process allows us to solve a number of important pedagogical problems, in particular, to develop students' creative abilities and the ability to analyze the condition of the problem and select an experimental model, improve the skills of applying the laws of chemistry, and the like [1].

The choice of problem solving method depends on the students having theoretical knowledge and practical skills.

Pupils should be taught to choose a rational way of solving experimental problems. At the same time, students form the ability to analyze tasks, make plans for decisions and reports.

In the class of studying new educational material, experimental tasks can be used in various aspects: at the beginning of a lesson, to nominate a problem and arouse students' cognitive activity; during the lesson – in the study of the chemical properties of substances or substances; at the end of the lesson – to consolidate new knowledge.

In the lesson of consolidation of knowledge and the formation of practical skills, experimental tasks can be used at its different stages in order to teach students to apply their knowledge to solve practical problems, or to study the device and the principle of the device and acquire the ability to use it.



In the lessons of generalization and deepening of knowledge, solutions to experimental problems are organized to specify the content of physical concepts and to establish new methods for measuring physical quantities and establishing new information about the phenomenon studied.

In knowledge control lessons, solving experimental problems will help test students' ability to apply knowledge in familiar and unfamiliar situations, analyze facts and take a critical look at the results of a chemical experiment.

At the lessons of control and accounting of students' knowledge, as well as at the lessons of generalization and deepening of knowledge, a significant part of the lesson and even the entire lesson can be devoted to solving experimental problems. It is advisable to solve complex problems, in particular the combined ones, which require knowledge of various sections of chemistry.

The ability to solve problems is one of the main indicators of the level of students' mastery of knowledge in chemistry. However, students often cannot solve a difficult task, although they discover the knowledge of theoretical material, they know the definition, the basic formulas, the laws, and solve standard problems. The reason is that students are used to solving typical tasks, and problems of an unknown type cause them to be confused [10]. The tasks are useful, as a result of which students get new information or acquire skills, tasks that make you think logically, based on theoretical knowledge, but with a creative approach. These criteria are exactly the experimental tasks.

Selecting experimental tasks, it is necessary to take into account the age of students, their psychological characteristics and the level of knowledge in chemistry. Experimental tasks are highly effective when students have sufficient knowledge of the relevant material. The form of the problem statement should be convenient for solving at each stage of the lesson.

Today there are many manuals and periodicals in which you can find a selection of experimental problems on a particular topic and are ready to solve them. However, the current trend is the introduction of information technology training in the process of formation of the subject competence of students. It can be said with confidence that students' performance of experimental tasks using information and communication technology tools will be more interesting for students and more productive [1].

## **2.2 Virtual chemical laboratories as a tools of teaching chemistry**

When studying chemistry at school, one of the most difficult tasks facing the teacher is to familiarize students with real chemical objects and processes. This difficulty is due to the simplicity and lack of equipment in school chemical laboratories, restrictions on the use of certain chemical compounds in them, reduction of time to study certain topics in curricula, and the like.

A solution to these problems is to use information and communication technologies in the educational process, in particular spreadsheets [16; 17], augmented reality tools [12; 18] and virtual chemical laboratories (VCL) [11].

According to O. V. Trukhin, a virtual laboratory "is a hardware-software complex that allows experiments to be carried out without direct contact with a real installation

or in the complete absence of it. In the first case, we are dealing with a so-called laboratory setup with remote access, which includes a real laboratory, software and hardware to control the installation and digitization of the data, as well as means of communication. In the second case, all processes are modeled using a computer” [19].

So, under the virtual laboratories understand two types of software and hardware systems:

- laboratory installation with remote access (remote laboratories);
- software that allows to simulate laboratory experiments – virtual laboratories (in the narrow sense) [19].

The advantages of virtual chemical laboratories are:

- no need to purchase expensive equipment and reagents. Due to inadequate funding, many school chemical laboratories have old equipment installed that can distort the results of experiments and serve as a potential source of danger for students. Also, in addition to equipment, consumables and reagents are required, the cost of which is quite high. It is clear that computer equipment and software are also expensive, but the universality of computer equipment and its wide distribution and availability somewhat compensate for this disadvantage;
- the possibility of modeling processes, progress or observations of which are fundamentally impossible in the laboratory. Modern computer technologies by means of visualization on the monitor screen provide an opportunity to observe processes that cannot be observed in real conditions without the use of additional equipment, for example, due to the small size of the observed particles or difficult to achieve conditions (ultra high or ultra low temperatures, pressure, etc.);
- the possibility of penetrating into the subtleties of processes and observing the details of a phenomenon that occurs on a different time scale, which is important for processes occurring in a fraction of a second or, on the contrary, last for several years;
- no immediate danger to the lives and health of students. Safety is an important advantage of using VCL, especially in cases where the work involves, for example, the use of hazardous chemicals or devices associated with the use of high temperatures, pressures, electric current, etc;
- saving time and resources for transferring the results into electronic format;
- the possibility of using VCL for informal education and distance learning, is to ensure the possibility of performing laboratory work in chemistry for the lack of access to school laboratories, including when working with children with limited physical abilities;
- the development of skills to find the optimal solution, the ability to transfer the real problem in model conditions and vice versa.

Perhaps the disadvantage of using virtual chemical laboratories is that the model objects created by the computer are completely supplanted by the objects of the child in the real world. But working with sign systems is the basis of analytic-synthetic activity, that is, thinking does not exist outside of abstraction and symbolization. Also,

significant shortcomings of the VCL are the limited information that they transmit to various users' senses, and the inability of students to develop skills in working with real laboratory objects.

By the way of visualization, laboratories are distinguished using two- and three-dimensional graphics and animation.

Also, virtual laboratories are divided according to the way they represent knowledge of the subject area. In one case, virtual laboratories are based on individual facts, limited to a set of pre-programmed experiments. They represent a specific set of laboratory studies, compiled in accordance with the curriculum. Experiments in such virtual laboratories can only be viewed. Intervention in their course is impossible [7, p. 131-132].

Otherwise, conducting virtual laboratory experiments is based on a mathematical model of a real chemical process. Such virtual laboratories provide for the possibility of changing the experimental conditions within certain limits and adequately reflecting these changes in its results. Licensed versions of such programs, as a rule, provide an opportunity to create your own laboratory work. Such virtual laboratories contribute to independent knowledge of the world by students and provide an opportunity for the teacher to realize their creative abilities regarding the chemistry learning process.

The development of VCL, based on mathematical modeling of real chemical processes, is more complex and time-consuming, but significantly expands the possibilities of their application [7, p. 132].

Examples of such VCL are Crocodile Chemistry, Model ChemLab [9] and Virtual Lab (VLab) [4].

Any of the VCL is only a model of the real world, and therefore, like any other model, there is a certain limitation, simplicity. Different virtual chemical laboratories have a different level of simplicity compared to real chemical laboratories: different in detail graphic display of objects, lack of transmission of smells and tactile sensations of objects manipulated in a virtual environment [13].

In our opinion, the most appropriate for use in the process of solving experimental chemical problems is such virtual chemical laboratories that allow the user to actively intervene in the course of the process, to offer and experimentally test their own algorithms for solving. The only virtual chemical laboratory that meets these requirements and is freely available is the Virtual Lab, so we decided to implement the development of a set of experimental problems in it.

### **3 Methodical basis for the development of a set of experimental tasks in chemistry for students in grade 9 in the cloud-oriented virtual chemical laboratory VLab**

#### **3.1 Features of the virtual chemical laboratory VLab**

The most accessible of the modern VCL, providing the ability of the user to intervene in the course of a virtual experiment, as well as the possibility of developing their own virtual laboratory work is the Virtual Lab (VLab).

The goal of the VLab virtual chemistry lab, which is a ChemCollective product, is to create flexible, interactive learning environments in which students can approach chemistry as practicing scientists.

ChemCollective began with work on the IrYdium Project's Virtual Lab in 2000. The project was to create training exercises designed to provide interactive, interesting materials that link chemical concepts with the real world.

The project leader is Dr. David Yaron, Associate Professor of Chemistry, Carnegie Mellon. Most of the original exercises included in this virtual lab were developed by a team at Carnegie Mellon, including D. Yaron, experienced software engineers, student programmers, educational consultants, and editors [3].

Virtual chemical laboratory Virtual Lab is free to install, use and distribute. It can be used both online (by running the virtual lab plugin from the ChemCollective website using any browser) or locally by downloading the installation files and installing the program on the computer.

Virtual Lab can also be integrated with the Moodle system using a special plugin. This makes it possible to apply the individual tasks of the virtual lab directly to the specific topics of the Moodle course [11].

In each assignment of the virtual chemical laboratory VLab, access to chemical reagents, which may include general purpose reagents or compounds specific for a given job, as well as chemical glassware (beakers, conical flasks, graduated cylinders, pipettes, volumetric flasks of various volumes, also a 50 ml burette and pin-up plastic glass) and equipment (Bunsen burner, weighing hook and scales).

A separate panel of the program window is designed to provide information about a substance or a mixture: name, volume, state of aggregation, amount of substance (mol or g), concentration (mol/l or g/l), spectrometer data, pH meter, and thermometer. Some of these tools can be disabled if this is required by the condition of the problem, which is solved in this virtual laboratory (see Fig. 1).

All actions with dishes and substances in it are performed in drag and drop mode, that is, by simply dragging objects with the left mouse button. The same operations, as well as some specific actions, can be carried out through the menu that appears when you click on an object with the right mouse button [20].

The essence of the program is to download certain tasks and solve them experimentally or calculated with the subsequent experimental verification of the result. There are no restrictions on the number of attempts to perform experience on restrictions on the use of certain quantities of reagents and materials.

Using the exercises of the virtual laboratory VLab, according to its developers, provide the ability to:

- help students who have missed class work in the laboratory to do an experiment from their personal computer, without the need to do work under the supervision of a teacher;
- supplement current work and homework on paper with exercises that allow students to use chemical concepts to design and perform their own experiments;
- monitor the correctness of the assignments of students (students use a virtual laboratory to check the results of their own calculations or qualitative forecasting

- without risk to their own health);
- to supplement the demonstration experiment conducted in the classroom (teachers first carry out a demonstration in the classroom so that students can see the actual chemical processes, and the students then study the chemical system and processes independently, guided by the tasks in the virtual laboratory).

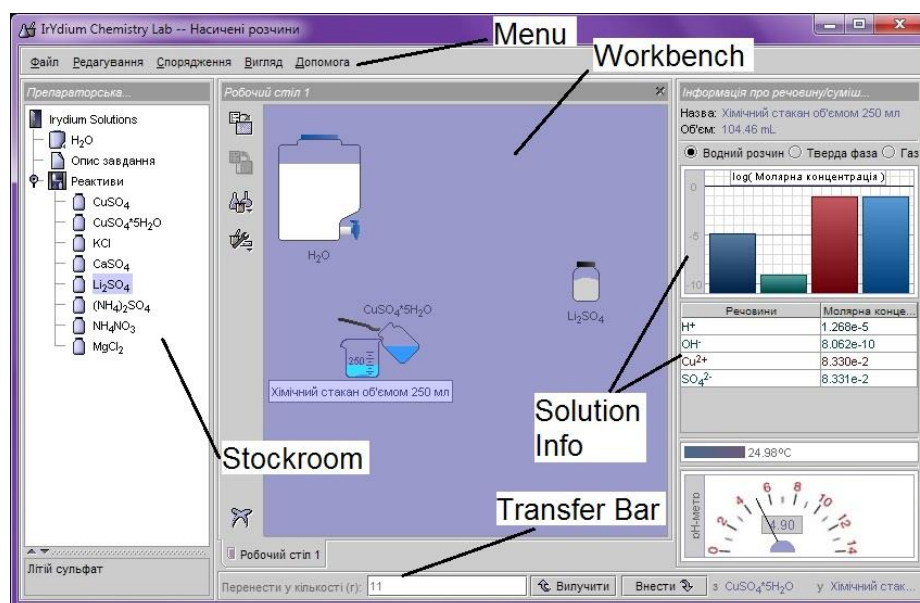


Fig. 1. VLab window with virtual laboratory work

Virtual Lab software currently includes more than 50 exercises and tasks that are designed to assimilate chemical concepts, mainly related to the study of solutions and processes in them: moths, stoichiometry and limiting reagents (tasks for excess), density, dilutions, dissociation constant, acids and bases, thermochemistry, solubility, chemical equilibrium, redox processes [2].

The installation package of Virtual Lab contains thirteen launch files for this program in different languages, among which Ukrainian since 2014 has been. Running the local version of the program, as well as the old online version, required the presence of a Java plug-in. Recently, this plugin has been blocked by most browsers and antivirus programs, it requires separate settings on the system, therefore, in 2017, the HTML5 version of the VLab was launched on the ChemCollective website in 2017, which currently supports only three languages: English, Spanish and Italian.

On the old version of the ChemCollective site (<http://collective.chem.cmu.edu>), you can download a special task editor, the Virtual Lab Authoring Tool, which allows you to both modify existing tasks and develop your own from scratch for the local version of the program.

In the task set, included in the standard version of the VLab program, most of the virtual works are oriented to a level higher than the level of the basic school – core, or

college and university. The content of a certain number of tasks is structured in such a way that all of them are full-fledged study and research tasks [11]. Our work was thus aimed at developing tasks that can be classified as experimental chemical tasks on the “Solutions” topic, were coordinated with the curriculum, and at the same time were available for primary school students in terms of complexity.

### 3.2 Creation of laboratory work in a virtual laboratory VLab

In order to create your own laboratory work, you need to understand how this virtual lab works. The virtual laboratory is launched by running the default.xml file (or default\_uk.xml for the Ukrainian version), which is located in the assignments directory. This is the default virtual lab file. This file contains individual properties of the program’s working area: the availability of tools (thermometer, pH meter, windows with information about the chemical composition of substances and solutions) and the available modes of substance transfer (accurate transfer, transfer of rounded quantities and realistic transfer). These tools and transfer modes can be either available for work, all or some of them can be turned off depending on the needs of the task scenario. Also in this file are the ways in which the working area of the program is filled with reagents, possible physicochemical processes with their participation, a description of the work task, and the like. These default paths lead to files that are in a subdirectory with the same name as the control xml file — that is, the files to work with, are guided by the default\_uk.xml file, are in the default\_uk directory (the path to it is in the program directory assignmetns / default\_uk). The directory referenced by the control xml file contains typically four files:

- filesystem.xml – contains information about the solutions (reagents) planned for use in this virtual laboratory work and the dishes in which they are contained, their volume or mass, and a brief description of this reagent (name, concentration, etc.);
- reactions.xml – contains information on all possible (planned) chemical reactions with a specific set of substances in this virtual laboratory work;
- species.xml – contains information on all substances available in this virtual laboratory work and their properties (color, state of aggregation, thermodynamic parameters, molar mass, etc.);
- problem\_description.html – contains a text description of the task and instructions for performing virtual lab work.

VLab versions higher than 2.1.0 may also contain the spectra.xml file, which contains the spectral characteristics of the substances that will be displayed in the photocolimeters window, if it is available for use in this work.

Other laboratory works are started on the same principle, only the control xml-files are located in separate thematic sub-subdirectories in the subdirectories of language localization, for example, the control xml-file of the localized Ukrainian work “Determining the solubility of  $\text{CuCl}_2$  at different temperatures” CuClSolu.xml is located along the way assignmetns / problems\_uk / solubility.

The list of control xml files with the path to them and a brief description of the work is in the ProblemIndex\_uk.xml file (ProblemIndex.xml for the standard English

version) in the root directory of the program. From this file that the list of laboratory works available for execution is called up via the menu “File” → “Load task”.

Any of these files can be edited using Notepad (it is important to save changes in the UTF-8 encoding) or any xml file editor. But a more optimal option is to use the special editor Virtual Lab Authoring Tool. There are several options for creating a new laboratory work: from scratch, editing and saving the default xml file, and based on another work. The second way is faster and more rational, since it allows partially (and in some cases, possibly completely) using those reagents, equipment and other necessary parameters of work, since they have already been entered and are guaranteed to work. To make this change, open the control xml file in the Virtual Lab Authoring Tool editor and select “Save As ...” in the “File” menu, specify the new file name and its location. In our case, it was the School catalog, which we created specifically for this set of works. A directory with content files is automatically generated.

Henceforth control xml-file in the editor Virtual Lab Authoring Tool need to edit.

The editor window has several tabs, each of which changes a certain part of the work data (see Fig. 2):

- General – contains fields for entering the title of the work, the last name of the author and a brief description of the content of the work.
- Permissions – contains two tabs: Viewers to specify the tools for viewing the properties of substances and their chemical composition will be available during the work; and Transfer Bars to determine the substance transfer parameters available in the job.
- Species – contains tools for creating and editing substances needed in this work. In addition to the formula, the molar mass and the name of the substance, the state of aggregation, as well as its coloring parameters, its standard enthalpy of formation and entropy are obligatory characteristics – these data will be used to simulate chemical reactions between the corresponding substances.
- Reactions – contains tools for planning the flow of physicochemical processes, by defining reactive particles as reagents or reaction products and setting appropriate coefficients.
- Stockroom – provides the ability to create and edit the contents of the “Stockroom” in the virtual laboratory – add cabinets, dishes with reagents, accompanying files (description of the task, etc.).

At the end of the work in the editor Virtual Lab Authoring Tool you need to save the changes and make the created work in the registry of works so that it becomes available for use. To do this operation, a block is created in the ProblemIndex\_uk.xml file (editing with a notepad or xml editor):

```
<DIRECTORY name="Назва блоку лабораторних робіт">  
  <PROBLEM url="assignments/problems_uk/school/назва  
файлу.xml">  
    <TITLE>Назва роботи</TITLE>  
    <AUTHOR>Автори</AUTHOR>  
    <DESCRIPTION>
```

Короткий опис завдання роботи  
 </DESCRIPTION>  
 </PROBLEM>  
 </DIRECTORY>

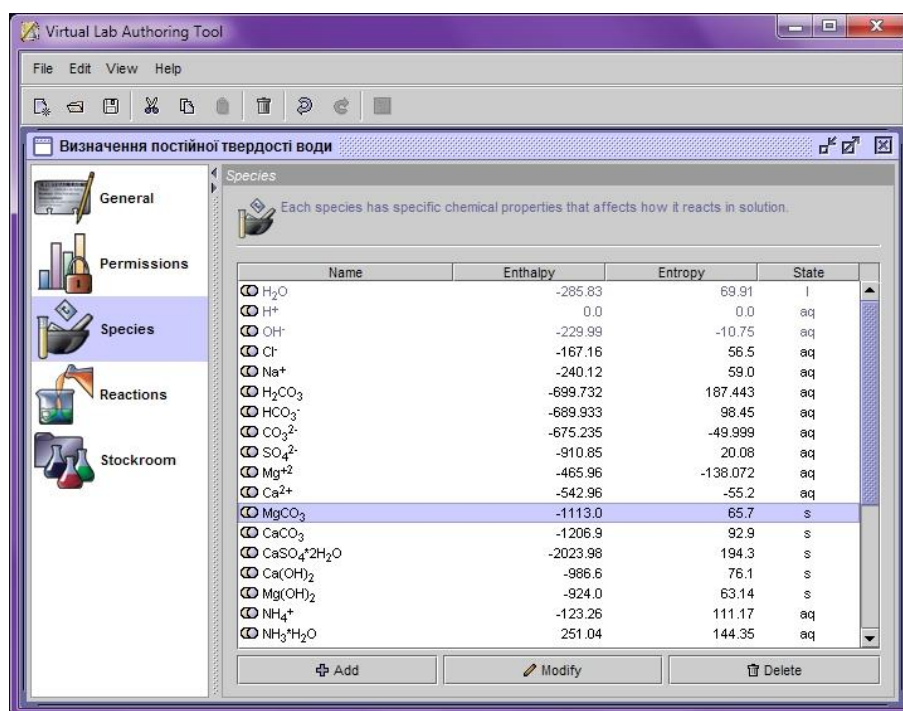


Fig. 2. Editor Virtual Lab Authoring Tool window

A block limited by <DIRECTORY> ... </ DIRECTORY> tags can contain as many individual works as desired, each of which is separated by <PROBLEM> ... </ PROBLEM> tags.

Created or edited works become available after the next program launch.

### 3.3 A set of experimental chemical tasks in a virtual chemistry lab VLab for use in school

To test the possibilities of using the virtual chemistry laboratory Virtual Lab to support the implementation of experimental tasks in chemistry, we chose the topic “Solutions” studied in grade 9.

The chemistry curriculum in grade 9 [5] provides for the solution of experimental problems on this topic, as well as the reaction equations using solutions with a certain mass fraction of the solute; use of demonstration experiments (thermal phenomena during dissolution: dissolution of ammonium nitrate and concentrated sulfuric acid in



water, studies of substances and their aqueous solutions for electrical conductivity, exchange reactions between electrolytes in aqueous solutions) conducting laboratory studies (detection of hydrogen and hydroxide ions in solutions, established approximate pH values of water, alkaline and acidic solutions (sodium hydroxide, hydrochloric acid) using a universal indicator, pH studies search and cosmetic products, the exchange reaction between electrolytes in aqueous solutions, accompanied by precipitation, the exchange reaction between electrolytes in aqueous solutions, accompanied by the evolution of gas, the exchange reaction between electrolytes in aqueous solutions, followed by water absorption, the detection of chloride, sulfate and carbonate ions in solution) carrying out practical work (ion exchange reactions between electrolytes in aqueous solutions) of executing a home experiment (preparing colloidal solutions (jelly etc.)), preparation and protection of educational projects (“Electrolytes in modern accumulators”, “Growing of crystals of salts”, “Production of solutions for provision of medical assistance”, “Research of soil pH of the area”, “Investigation of the influence of acidity and alkalinity of soils on plant development”, “Research pH of atmospheric precipitation and their influence on various materials in the environment”, “Investigation of natural objects as acid-basic indicators”, “Investigation of the pH of the mineral water of Ukraine”).

The most important and most complex parts of this topic are the solubility of substances, its dependence on various factors. Saturated and unsaturated, concentrated and diluted solutions. Thermal phenomena accompanying the dissolution of substances, dissolution as a physical and chemical process, the concept of hydrates, electrolytic dissociation etc. Therefore, experimental tasks should be directed to the study of precisely these substantive parts of the topic.

After analyzing the technical and visual capabilities of the Virtual Lab, we determined that it would be most appropriate to create virtual experimental tasks related to the dissolution process (its energy and quantitative characteristics), the dissociation process of substances in a solution and determine its pH, as well as the use of some qualitative reactions, indicators and the like. The tasks associated with the study of the properties of colloidal solutions, the flow of certain exchange reactions, the extraction of crystals, the study of the analytical effects of qualitative reactions associated with the formation of precipitation cannot be realized either due to the limited possibilities of modeling chemical phenomena in the VLab and due to the limitations of visual accompaniment (for example, to conduct qualitative reactions with the formation of sediment among the equipment in the VLab there are not enough test tubes, and the presence of sediment and its color become noticeable in a glass x on the desktop of the virtual laboratory only in quantities of a few grams or more, does not comply with the principles of qualitative chemical analysis).

Based on all the above, we have created a trial set of experimental problems on the topic “Solutions”, which contains seven tasks. The works contain instructions for solving problems and a number of questions that students need to answer.

For example, the laboratory work “Precursor” suggests that the student present himself as a laboratory technician and carry out dilutions of concentrated sulfuric acid, which is on the list of precursors. The task is to prepare equal volumes of solutions with the indicated concentrations.

In the work “Separation of salt mixture”, it is necessary to separate the mixture of crystalline potassium chlorate and sodium chloride by recrystallization of potassium chlorate, based on the difference in the solubility of these salts. The task contains the order of actions that will help to perform the work. The purpose of this task is to familiarize students with the methods of purification and separation of substances, the dependence of the dissolution of salts on temperature.

To demonstrate the preparation of saturated solutions, you can use the work “Preparation of saturated solutions of various chemical compounds”. Here the student will be able to prepare solutions by changing the temperature, and on the basis of the data obtained, construct curves for the concentration of a saturated solution of a substance on temperature. The aim of the work is to study the change in the solubility of substances from temperature, the formation of skills in the preparation of saturated solutions, the analysis of the experimental data.

The study of thermal effects of dissolution can be carried out in the work “Thermal effects of dissolution”. In the description, it is reported that during the dissolution of the substance various physical and chemical processes take place with both the solute and the solvent. One of the external indicators that can be easily fixed is the thermal effect observed when various substances are dissolved. The task is to investigate the thermal effects of dissolution of various crystalline compounds in water and to draw appropriate conclusions and assumptions regarding the processes leading to the occurrence of these effects. The purpose of the work is to form an understanding of the thermal phenomena that accompany the process of dissolution and test them in practice, consolidating knowledge about exo- and endothermic processes.

The overwhelmingly developed tasks contain a sufficient number of hints so that the student can experiment in a virtual laboratory independently, for example, on a home computer, and some of the tasks are quite realistic to reproduce in a real school chemistry laboratory, given the time and possibilities (in this case problem solving in a virtual laboratory can be used as a training option to verify the correctness of theoretical calculations and repeat the order needed imyh action).

A set of these laboratory works are posted on the website of the Department of chemistry and methods of learning chemistry at the KSPU (<https://kdpu.edu.ua/khimii-ta-metodyky-ii-navchannia/tsikava-khimiia/dlia-vseznaiook/5928-virtualna-khimichna-laboratoriia.html>) with the aim of further introducing schools into the educational process and receiving feedback on improving the quality and expansion of this set.

## 4 Conclusions

1. Experimental tasks in chemistry is a separate type of chemical problems, the solution of which is necessarily accompanied by the practical implementation of a chemical experiment.
2. Experimental chemical tasks, as one of the varieties of experimental activity of students in chemistry, is an integral part of an effective teaching and educational process, and led to the methodological feasibility of their use in various types of lessons, at different stages of a lesson and in extracurricular work.

3. Pre-profile chemistry training contains a significant amount of experimental activity of students, and one of the ways to overcome the contradiction between the need to carry out a training chemical experiment and the lack of sufficient time, necessary equipment and reagents, the use of virtual chemical laboratories — special computer programs that make it possible to simulate the physical chemical phenomena or to conduct experiments without direct contact with a real set th or the complete absence thereof.
4. The advantages of the virtual chemistry laboratory Virtual Lab should include free distribution, the ability to edit existing and create your own laboratory work (tasks), the availability of the Ukrainian version, user-friendly design, minimum system requirements, the possibility of active user intervention during the virtual laboratory work.
5. Mathematical model of chemical processes in the virtual chemical laboratory. The Virtual Lab uses the thermodynamic characteristics of substances and calculates the parameters of the equilibrium state in various systems (mainly solutions), applying the dependence of the isobaric-isothermal potential and the equilibrium constant. This determines the simplicity of the process of creating models of equilibrium processes for this virtual laboratory and their adequacy to real processes.
6. The main drawbacks of the Virtual Lab program is the use of corresponding thermodynamic parameters in modeling chemical processes only as a first approximation, the lack of opportunities to model the kinetic effects of chemical processes, the inability to adequately simulate the processes occurring with the release of gas compounds and the like.
7. Considering the possibilities and advantages of the virtual chemical laboratory Virtual Lab and analyzing the chemistry curriculum for the 9th grade, it was found out that the most appropriate development of a set of experimental chemical problems for schoolchildren in the topic “Solutions” is one of the main ones in the 9th grade and before profile training in general. The developed set currently consists of seven tasks and implies its further expansion and improvement taking into account the results of its practical implementation in the educational process of schools.

## References

1. Brajko, V.I., Mushkalo, N.N.: Experimental Tasks on Inorganic Chemistry: A Manual for Teachers. Radyanska shkola, Kyiv (1982)
2. ChemCollective: Introduction for Instructors. <http://chemcollective.org/teachers/introforInstructors> (2018). Accessed 21 Mar 2019
3. ChemCollective: Introduction. [http://chemcollective.org/about\\_us/introduction](http://chemcollective.org/about_us/introduction) (2018). Accessed 21 Mar 2019
4. ChemCollective: Virtual Labs. <http://chemcollective.org/vlabs> (2018). Accessed 21 Mar 2019
5. Chemistry. Grades 7-9: Curriculum for General Education Institutions. <https://mon.gov.ua/storage/app/media/zagalna%20serednya/programy-5-9-klas/onovlennya-12-2017/10-ximiya-7-9.doc> (2017). Accessed 21 Mar 2019
6. Derkach, T.M., Rozhko, O.K.: Software for conducting “virtual” laboratory works on chemistry. Theory and methods of learning fundamental disciplines in high school. **5**, 319–

- 324 (2008)
7. Derkach, T.M.: Information technologies in the teaching of chemical disciplines. DNU, Dnipropetrovsk (2008)
  8. Grygorovych, O.V.: Chemistry: A textbook for Grade 8. Ranok, Kyiv (2016)
  9. Model Science Software Products - Model ChemLab. <http://modelscience.com/products.html> (2019). Accessed 3 Apr 2019
  10. Mukan, L.: Tasks as a factor in the formation of intelligence of students. *Biology and chemistry at school*. 6, 16–21 (2002)
  11. Nechypurenko, P.P., Semerikov, S.O.: VlabEmbed – the New Plugin Moodle for the Chemistry Education. In: Ermolayev, V., Bassiliades, N., Fill, H.-G., Yakovyna, V., Mayr, H.C., Kharchenko, V., Peschanenko, V., Shyshkina, M., Nikitchenko, M., Spivakovsky, A. (eds.) 13th International Conference on ICT in Education, Research and Industrial Applications. Integration, Harmonization and Knowledge Transfer (ICTERI, 2017), Kyiv, Ukraine, 15-18 May 2017. CEUR Workshop Proceedings, vol. 1844, pp. 319–326. <http://ceur-ws.org/Vol-1844/10000319.pdf> (2017). Accessed 21 Mar 2019
  12. Nechypurenko, P.P., Starova, T.V., Selivanova, T.V., Tomilina, A.O., Uchitel, A.D.: Use of Augmented Reality in Chemistry Education. In: Kiv, A.E., Soloviev, V.N. (eds.) Proceedings of the 1st International Workshop on Augmented Reality in Education (AREdu 2018), Kryvyi Rih, Ukraine, October 2, 2018. CEUR Workshop Proceedings, vol. 2257, pp. 15–23. <http://ceur-ws.org/Vol-2257/paper02.pdf> (2018). Accessed 30 Nov 2018
  13. Nechypurenko, P.P.: Some aspects of simulation of real chemical processes and systems in virtual chemical laboratories. Theory and methods of e-learning. 3, 238–244 (2012)
  14. Pak, M.S.: Theory and methods of teaching chemistry: a textbook for universities. Publishing house of RGPU named after A. I. Gertsen, Sankt-Peterburg (2015)
  15. Savchyn, M.M.: Use of algorithms in the course of chemistry as a means and method of forming the subject competences of students. Scientific notes of the Vinnitsa State Pedagogical University named after Mikhail Kotsiubynsky, Series: pedagogy and psychology. 44, 324–328 (2015)
  16. Semerikov, S.O., Teplytskyi, I.O., Yechkalo, Yu.V., Kiv, A.E.: Computer Simulation of Neural Networks Using Spreadsheets: The Dawn of the Age of Camelot. In: Kiv, A.E., Soloviev, V.N. (eds.) Proceedings of the 1st International Workshop on Augmented Reality in Education (AREdu 2018), Kryvyi Rih, Ukraine, October 2, 2018. CEUR Workshop Proceedings, vol. 2257, pp. 122–147. <http://ceur-ws.org/Vol-2257/paper14.pdf> (2018). Accessed 30 Nov 2018
  17. Semerikov, S.O., Teplytskyi, I.O., Yechkalo, Yu.V., Markova, O.M., Soloviev, V.N., Kiv, A.E.: Computer Simulation of Neural Networks Using Spreadsheets: Dr. Anderson, Welcome Back. In: CEUR Workshop Proceedings (CEUR-WS.org) (2019, in press)
  18. Syrovatskyi, O.V., Semerikov, S.O., Modlo, Ye.O., Yechkalo, Yu.V., Zelinska, S.O.: Augmented reality software design for educational purposes. In: Kiv, A.E., Semerikov, S.O., Soloviev, V.N., Striuk, A.M. (eds.) Proceedings of the 1<sup>st</sup> Student Workshop on Computer Science & Software Engineering (CS&SE@SW 2018), Kryvyi Rih, Ukraine, November 30, 2018. CEUR Workshop Proceedings (CEUR-WS.org), vol. 2292, pp. 193–225. <http://ceur-ws.org/Vol-2292/paper20.pdf> (2018). Accessed 21 Mar 2019
  19. Trukhin, A.V.: On the use of virtual laboratories in education. *Open and distance education*. 4(8), 67–69 (2002)
  20. Yaron, D., Karabinos, M., Lange, D., Greeno, J.G., Leinhardt, G.: The ChemCollective – Virtual Labs for Introductory Chemistry Courses. *Science*. 328(5978), 584–585 (2010). doi:10.1126/science.1182435
  21. Zarubko, V.P.: Development of creative thinking of students through solving problems. Chemistry teacher's blog. <http://blog.himiya.in.ua/metodychna-robota/rozvytok-tvorchogomyslennja.html> (2015). Accessed 21 Mar 2019

# Adaptive Testing Model as the Method of Quality Knowledge Control Individualizing

Nonna Shapovalova<sup>[0000-0001-9146-1205]</sup>, Olena Rybalchenko, Iryna Dotsenko, Svitlana Bilashenko, Andrii Striuk<sup>[0000-0001-9240-1976]</sup> and Levon Saitgareev

Kryvyi Rih National University, 11, Vitaly Matusevich Str., Kryvyi Rih, 50027, Ukraine

{shapovalovann09, ellinaryb, irado441, SvitlanaViktorivnaBilashenko, andrey.n.stryuk}@gmail.com

**Abstract.** The mission of the work is to develop and theorize the efficiency of application of the knowledge control system on the basis of adaptive testing technology, which combines the specifics of the professional and educational activity and the monitoring of the quality of training and the possibility of self-control of students, to develop a set of test assignments in the discipline “Artificial Intelligence Systems”. Object of research is a software tool for monitoring students’ knowledge in higher educational establishment. The subject of research is the development of software for an adaptive knowledge control system using machine learning device. Research goals: to develop a set of test case of different levels of complexity; to determine the structure, architecture and specificity of the application of the machine learning algorithm for the formation of a variable level of testing complexity for each student; develop appropriate software, guidelines and recommendations for adjusting and distributing issues by level of complexity. The result of the work is a complex of split-level application-oriented tasks for current and module control in the discipline “Artificial Intelligence Systems”, web-oriented software that allows you to quickly monitor the quality of students’ knowledge and is appropriate for use in online and mixed mode of training.

**Keywords:** adaptive testing, machine learning, psychological types of personality.

## 1 Introduction

In the modern educational space there are many forms and methods for controlling students’ knowledge and skills. The effectiveness of both systems of the educational process and the quality of specialist training depend on the proper management of the assessment. Adaptive testing is a technology for determining the level of students’ knowledge, where each next question is automatically selected based on the answers to previous questions and a predetermined level of complexity. The main difference between adaptive testing and classical tests is the dynamic (in real time), and not the

static definition of the list of questions. In this case, the choice of the next question is determined by the personal characteristics of each individual student.

The use of the system of adaptive control of knowledge makes it possible to solve a number of urgent tasks such as the creation of subject complexes of test tasks; creation of tools for individualized diagnostics of the level of knowledge and degree of material digestibility; the formation of a visual representation and interpretation of test results. A feature of the use of adaptive technologies in education is that the quality control of knowledge occurs constantly in the process of teaching the discipline, and not only during the modular or session control. This fact allows the teacher to have operational and objective information about the quality of learning material, its correct understanding of the independent work of students and the like. Thus, adaptive learning systems, in particular adaptive testing, make it possible to optimize the learning process.

## **2 Research apparatus**

*The aim of the study* is to theoretically substantiate, develop and experimentally test the system of adaptive testing on the discipline “Artificial Intelligence Systems” in the professional training of bachelors in the specialty 121 – “Software Engineering”.

*Objectives of the study:*

1. To analyze the state of the problem of developing and using adaptive software for quality knowledge control.
2. To substantiate the choice of methods for implementing the system of knowledge quality control, taking into account the individual characteristics of the student.
3. To develop a universal system of adaptive control of knowledge in a particular discipline.
4. To fill the software-instrumental environment with content of test tasks of various levels of complexity to determine the quality of knowledge of bachelors in the specialty 121 – “Software Engineering” in the discipline “Artificial Intelligence Systems”.

*The object of research* is the development of web-based software with an adaptive interface for determining the level of knowledge.

*The subject of research* is the development of an adaptive system for testing bachelors in the specialty 121 – “Software Engineering” in the discipline “Artificial Intelligence Systems”.

*Research methods:* analysis of sources from the investigated topic, methods for determining the psychological type of a person, methods of artificial intelligence for the individualization of knowledge control; modeling the learning process of classification algorithms; formalization of the constructed models; empirical method for determining the optimal parameters of the training model; method of object-oriented design and programming.

*The practical significance of the obtained results* is that a complex of tests in the discipline “Artificial Intelligence Systems” of various degrees of complexity has been

developed for the bachelors in the specialty 121 – “Software Engineering”. The complex of test tasks can be used to determine the quality of knowledge in various disciplines of the vocational training cycle, involving the mastering of artificial intelligence technologies; the developed software can be used as an ICT tool in the learning process of any discipline.

### **3 Theoretical foundations of adaptive testing**

The system of students’ knowledge control, which is an important component of any form of education, still needs to be updated and developed such knowledge control tools that meet the requirements of objectivity, comparability, predictability of assessment results and have clear criteria for assessment procedures.

The organization of the educational process is currently characterized by the widespread use of information and communication technologies, primarily the introduction of testing using computer technology. On the issues of computer testing to determine the level of students’ knowledge, a lot of research has been conducted, software tools have been created for generating and testing tests. Automated testing systems provide an increase in the efficiency of the educational process and are economical, but the lack of an individual approach to students, taking into account their personal characteristics, significantly reduces the objectivity, comparability and predictability of assessment results.

T. Hodovaniuk notes that the observance of the principle of an individual approach to teaching in higher education requires taking into account the level of intellectual development of a student, constant analysis of his academic and life experience, taking into account the level of independence and volitional development of each person. This approach is aimed at achieving students a common goal, but in different ways. The essence of this principle of learning is the multi-level independent activity of students, which purpose is to facilitate the assimilation of educational material in accordance with individual mental abilities and the existing level of students’ knowledge [12].

As M. Mazorchuk notes, traditional automated testing systems have a significant drawback: each subsequent test task is generated by random selection from the entire set of tasks of a particular topic [17]. With such an algorithm, situations where a student with a low level of knowledge is presented with complex tasks are not uncommon; the result is an almost complete lack of answers. Polar situation will be such that when a student with a high level of knowledge will be offered light tests. In this case, the tested person will not be able to realize their abilities. That is, to ensure objectivity and comparability of the results, the average complexity of the test task must correspond to the predicted level of student training. Such a selection of tasks can be accomplished using adaptive testing.

By definition of A. Malygin, adaptive testing is a scientifically based method of controlling the level of knowledge of students, which is implemented, using automated processes for generating, presenting and evaluating the results of performing adaptive tests. Each subsequent test question is automatically selected based on the responses received to previous questions and a predetermined level of difficulty [16]. The main

difference between adaptive testing and classical tests is the dynamic (in real time), and not the static definition of the list of questions. The choice of the next question is determined by the personal characteristics of each individual student.

Adaptive testing makes knowledge control procedures effective due to an individual approach and offering the student tasks corresponding to his level of training [19]. According to S. Zahrebelnyi, a tested face can be presented with fewer tasks with preservation of the diagnostic ability of the whole volumetric test [32]. Due to the adaptive approach, it is possible to significantly reduce the complexity and testing time.

The issue of adaptive testing was studied by many scientists and practitioners (A. Malygin [16], S. Zahrebelnyi [32], M. Brus [32], M. Mazorchuk [17], Yu. Koltsov [14], N. Dobrovolskaya [14], and others).

The scientific base of adaptive testing is the modern theory of tests – Items Response Theory (IRT), its provisions and parametric methods are examined in the research by G. Rash [21] and others.

The main idea of IRT is to justify the possibility of effectively predicting test results for tasks of different levels of complexity, which is a necessary requirement for adaptive test control systems.

The forecast is based on the following statements:

1. There are dormant parameters of the personality that are unattainable for direct observation. In testing this is the level of preparation of the tested person and the level of difficulty of the task;
2. There are indicative variables associated with dormant parameters available for direct observation. The values of the indicator variables give information about the value of the dormant parameters;
3. Dormant parameter, it is estimated to be one-dimensional. This means that, for example, a test has to measure knowledge in one subject area.

To implement the adaptive testing algorithm in this work, the one-parameter model IRT G. Rash is used. The model reflects the probability of success of the test as a function of one parameter – the difference in the level of training of the subject and the level of difficulty of the task [21].

$$P(u_{ij} = 1 | \theta_j, \delta_i) = \frac{e^{\theta_j - \delta_i}}{1 + e^{\theta_j - \delta_i}} \quad (1)$$

where  $u_{ij}$  – an estimate for the  $j$ -th for  $i$ -th task;  $\theta_j$  – level of preparation of  $j$ -th subject;  $\delta_i$  – characteristic of the  $i$ -th point of the test.

Model (1) is a logistic function, and its graph depicting the probability of a correct answer from the latent characteristic  $\theta$  is called the characteristic curve of the task (item characteristic curve (ICC)). In [2] V. Avanesov noted that test questions, besides the fact that they must differ in the level of complexity, must meet the following requirements: brevity; manufacturability; correct form; correct content; logical form of expression; uniformity of rules for evaluating responses and can be presented in various types: closed (multi-alternative and single-alternative), open, to establish correspondence between elements, to establish the correct sequence, situational test items.



M. Bondarenko, V. Semenets, N. Belous devoted their research to the question of evaluating test tasks of different types [4].

Formally, the model for evaluating the results of adaptive testing can be represented as a differential equation [1]. The respondent needs to perform  $N$  test tasks of the level of difficulty  $d_i = [1, D]$ , and the result of the test  $T$  depends on the results of the previous tasks and therefore changes continuously. For the assessment of knowledge, a continuous rating scale is used in the range  $[0, 1]$ , and the assessment for the performance of each test task is measured by a coefficient  $t_i \in [0, 1]$ . In this case, it is expedient to introduce a coefficient  $B$  in recalculating test results into an arbitrary points system. So, the lowest score is 1, and the highest –  $B$  points. Since any knowledge assessment system based on test execution makes it possible to guess the correct answer, it is necessary to enter a guessing coefficient  $g_i \in [0, 1]$ . Taking into account all the parameters, the model for evaluating the results of adaptive testing can be represented as (2).

$$f(N, d_i, t_i, g_i, B)=1 \quad (2)$$

For each of the types of test items, the coefficient  $t_i$  is calculated differently.

In this paper, the authors will propose to use closed single-alternative and multi-alternative test items, taking into account the possibility of guessing the correct answer. For evaluation of test tasks of different types, the technique proposed by N. Belous is used [4]. For problems with one correct answer,  $t_i$  is a binary value, takes the value 0 in the case of an incorrect answer and the value 1 in the case of choosing the correct answer option. In the case of test questions with several correct answers, the student may or may not have all the correct answers, or one or more incorrect answers, that is, to calculate  $t_i$ , it is necessary to consider not only the correctness of the answer to the task as a whole, but also the number of answer choices correctly chosen (2).

$$t_i = \frac{Qr_i}{QR_i + Qw_i}, \quad (3)$$

where  $Qr_i$  – the number of correct answers chosen by the respondent in the  $i$ -th task;  $QR_i$  – the number of correct answers in the  $i$ -th task;  $Qw_i$  – number of incorrect answers selected by the respondent in the  $i$ -th task.

The guessing coefficient for tasks with one correct answer among  $Q$  answers is calculated by the formula (3).

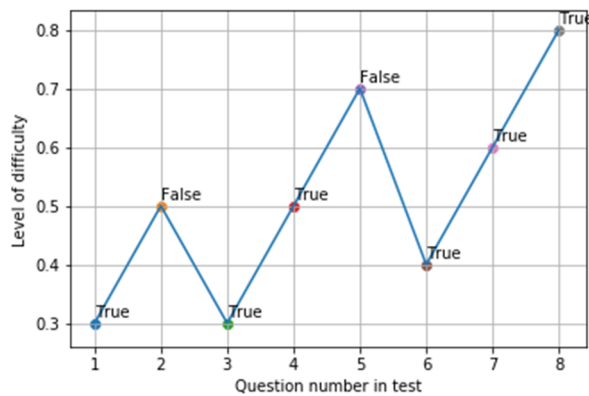
$$g_i = \frac{1}{Q} \quad (4)$$

In the case of several correct answers, the coefficient of guessing probability is calculated by the formula (4).

$$g_i = \frac{1}{2Q} \quad (5)$$

The task selection algorithm is based on the feedback principle: if a student answers correctly, the next task is selected at the highest level of complexity, and if the answer is incorrect, a low level is selected than the one to which the student gave the wrong

answer. During the first testing, the respondent level is set to  $R_0=0$ , and the first question of the test will automatically be offered from a high level of complexity. Depending on the correctness of the answers to the proposed questions, the level of preparedness is listed. Thus, after completing the next task, the following is selected such a level of complexity, which is calculated on the basis of the previous answer. An example of the procedure for selecting the level of complexity of each of the following questions is shown in Fig. 1. Despite all the advantages, in the concept of adaptive testing is not sufficiently implemented the assessment of the personal parameters of the test subject. Accounting in the system of adaptive learning traits of the personality of the student allows you to effectively achieve the goal of learning.



**Fig. 1.** Procedure for selecting the level of complexity of questions in the test

During the study, Yu. Koltsov and N. Dobrovolskaya came to the conclusion that it is reasonable to include the following qualities and personality characteristics to the core of the student's model: type of thinking; the form of knowledge representation is better perceived by the person; confidence when answering; level of learning. It is the consideration of these features that should influence the formation of the material that is submitted for testing according to the level of complexity and forms of knowledge representation [15].

Individual characteristics are a stable characteristic of a person that does not change at all or changes over a long period of time. They are determined using specially developed psychological tests. Persons who study may have an intuitive or theoretical-methodological thinking, different levels of anxiety during the response, motivation to learn and features of the processes of remembering and forgetting.

Accordingly, a task with different forms of knowledge representation can be offered for different categories of persons: analytical (analytical expressions, mathematical models, formalized descriptions), figurative (schemes, drawings, video fragments), heuristic (practical methods, heuristic descriptions).

## 4 Definition of psychological type

In the process of learning, innovative technologies are increasingly being introduced, one of which is the student-centered approach, which underlies many learning styles or models. The most popular learning model was the VAK model based on the psychophysiological features of information perception [30]. From the point of view of psychology, each person has his own psychological type, which is expressed in combination of character traits, describes its individuality and personality. Based on the psychophysiological features of perception of information, four psychological types are distinguished: audials, visuals, kinesthetic and digital (discretes). Visitors perceive most of the information through vision. This psychological type is the most common, since about 80-90% of information a person receives through vision. Audials are a rather rare type of people (5-7%), in which the auditory perception of information is more developed. The kinesthetic perceives reality through tactile sensations, in order to obtain any new knowledge or skills they must work it out on their own practical experience, but digitals (discretes) think in terms of functionality, using logic and numbers. The VAK model takes into account physiological properties when choosing the most appropriate way to perceive information depending on psychological type.

Psychologists and educators V. Barb and M. Milon announced the results of a detailed study of the introduction of VAK-techniques. They conducted an experiment, attracting 1000 students from southern California and proved that students learn the material more efficiently, and learning becomes preferable when taking into account the psychophysiological features of the perception of new information [3]. Studies by V. Barb have argued that when using the VAK model, the perception of information is facilitated, as a result, the learning process is improved. N. Fleming based on the model of V. Barb identified another psychological type [8] and the VAK model (visual / audial / kinesthetic) was expanded to the VAKR model (visual / audial / kinesthetic / reading). The teaching style according to the VAK methodology has become the most popular in the world teaching practice due to the simplicity of model building and ease of its use [28].

There are many techniques that allow you to determine a person's psychological type, but provided that this process is implemented as a separate software module, only those techniques that do not provide for visual contact with the subject will be considered. In order to select a method for determining a student's psychological type according to information perception, a number of psychological tests were considered: a test for determining the psychological type and propensity to work in groups or individually J. Reid [18]; diagnostics of the dominant perceptual modality of S. Yefremtsev [31]; a test for determining a certain integral indicator of the general abilities of V. Buzin, E. Vanderlik; methodology "Register of information assimilation style" A. Gregos (identifying priority methods for collecting information) [22].

For this work, the test "Diagnosis of the dominant perceptual modality of S. Yefremtsev" was chosen, as such, which most closely meets the following criteria: age of the test person, purpose, number of questions. The use of this test method makes it possible to determine the type of perception of the subject's information. In many

scientific papers, in determining the psychological type of a person, the authors rely on the test of S. Yefremtsev [5; 10].

## **5 Data and methods of individualization of control knowledge**

### **5.1 Structure of the main modules**

Designing an adaptive knowledge control system consists of the implementation of three modules that meet the objectives of the implemented system and constantly interact in the process of using the system: data collection; selection of content; personalization. The data collection module consists of primary (input) testing and saving test results for the discipline. At this stage, a student's model is formed on the basis of his psych-type, type of information perception channel (visual, audial, kinesthetic, digital), as well as the accumulation of information about the student's knowledge of the degree of assimilation of certain concepts.

Depending on the patterns of student behavior in the system, its features, reactions to changes in the levels of complexity of selected tasks, information about the user's image is summarized and the content is formed for certain types. So, it can be schemes, graphics, parts of a program code, objects of augmented reality, etc. [27, 29]. The implementation of the content selection module is based on the task of determining the optimal parameters for the type of presentation of the image of a student through the implementation of a machine learning algorithm that simulates a typical case study task. The personalization module includes the differentiation of tasks according to the level of complexity, displaying the progress of each student's success, the test forecast based on the number of attempts to pass the test and the average result achieved during all attempts.

### **5.2 Classification methods**

To implement content selection and personalization modules, it is necessary to solve the problem of classifying the image of each user in order to select the exact level of complexity of the next test task corresponding to the level of knowledge and the type of perception of a particular student. To solve this problem we will use the methods of machine learning (ML). ML is a rather large subdivision of artificial intelligence, studies methods for constructing algorithms capable of learning.

The investigated task belongs to the class of learning tasks by precedents (supervised learning). Each use case is a pair of "object – answer". It is necessary to find the functional dependence of the answers on the descriptions of the objects and build an algorithm that takes the description of the object at the input and gives the answer at the output. In the task of classifying a set of valid answers defined. They are called class labels. A class is the set of all objects with a given label value. To solve the problem of learning from precedents, the model of renewable dependence is fixed first of all. Then a quality functional is introduced, which value shows how adequately the model describes the observed data. The quality functional is usually defined as the average error of the answers given by the algorithm for all objects in the sample. The learning

algorithm is looking for a set of model parameters in which the quality functional on a given training sample takes the optimal value [26].

The process of developing a specific ML model consists of stages:

- process of preparation (presentation) of data;
- algorithm design process;
- training process of the algorithm on the available data;
- algorithm validation process on test data

At the presentation stage, the rules for coding elements and forming data structures are determined [11]. The objects of learning are the vectors that are formed from the signs presented in numerical form. We will use the following features: the psychological type of the person tested; form of information; level of progress of a tested person. The sign “psychological type of a tested person” refers to a nominal type (signs with disordered states) and can take on the value of one of certain psychological personality types: visual, audial, kinesthetic, and digital. Put each type of signs in accordance with the numerical value: 1 – visual; 2 – audial; 3 – kinesthetic; 4 – digital. The sign “information presentation form” is also nominal, and in the numerical form it takes the following values: 1 – analytical; 2 – figurative; 3 – heuristic; 4 – audio. The sign “progress level” reflects the dynamics of the indicator of the quality of knowledge at the time of classification and is calculated as the growth rate of the assessment coefficient for each question in the test. Since the sign of the “progress level” has the ordinal type, it is necessary to match the actual value of the growth rate indicator with the ordered numbers, they can be compared with each other, but the distance between them is not defined. If the growth rate is negative, the sign “progress level” is taken as 1, with zero – 2, with positive – 3. As a class is the level of complexity of the next task. The specified feature is a target, that is, its value must be predicted, it is ordinal in type, and it takes on the values: 1 – easy level; 2 – medium; 3 – difficult.

The classification problem can be solved by many methods of ML, in particular, by the Bayes classifier, a decision tree, an algorithmic composition of decision trees, an artificial neural network, etc. [23]. The Bayes classifier is a probabilistic classifier, based on the Bayes theorem to determine the probability of the sample object belonging to one of the classes. To implement this model, it is necessary to assume independence of variables, what is a disadvantage of this method, because otherwise the probabilities of belonging to classes are not exact. The main advantage of the Bayes classifier is that to determine the parameters of the model, a small amount of data is required, as well as moderate use of the machine resource, high speed and simplicity [6]. A decision tree is a family of algorithms that are widely used in ML technologies. The structure of the tree is the “leaves” and “branches”. On the “branches” of the decision tree, the conditions on which the forecast depends depend on, in the “letter” the predicted value is recorded, and in other nodes – the conditions on which the tree forks. As a rule, binary decision trees are used. Among the advantages of the method is simplicity and reliability. The disadvantages include the fact that building an optimal tree is an NP-complete problem; decision trees are very easily retrained, which requires the use of additional resource-intensive measures to combat retraining.

Artificial neural networks are a mathematical model of the functioning of biological neural networks – networks of nerve cells of a living organism. As in the biological neural network, the main element of an artificial neural network is a neuron. Interconnected neurons form layers, the number of which can vary depending on the complexity of the neural network and the tasks it solves. The theoretical foundations of programming such neural networks are described in many papers [15; 20; 25]. The advantages of the method include high fault tolerance, orientation to parallel calculations, no need to formalize data. However, this type of method has drawbacks: the inability to reproduce the result, the complexity and empirical nature of the definition of network architecture [7].

To date, the most effective classifier is the machine learning method – gradient boosting, which belongs to the class of compositional methods. Boosting is a way to create compositions from decision trees, within which the basic algorithms are built sequentially, one after another, and each next algorithm is chosen in such a way as to correct the errors of an already constructed composition (6).

$$a_N(x) = \sum_{n=1}^N b_n(x), \quad (6)$$

where  $b_n(x)$  – basic algorithms (decision trees) on the space of signs  $x$ .

To assess the quality of the algorithm, the loss function  $L(y,z)$  is defined, where  $y$  is the true answer for each object from the sample  $x$ ,  $z$  is the algorithm's prediction for the same object. The classification tasks use the logistic loss function (7).

$$L(y, z) = \log(1 + \exp(-yz)) \quad (7)$$

The first basic composition algorithm is based on the formula (8).

$$b_0(x) = \operatorname{argmax}_{y \in Y} \sum_{i=1}^l [y_i = y] \quad (8)$$

It returns the label of the most common sample class.

Learning the algorithm that is attached to the composition in each subsequent step is reduced to the task of learning from precedents. (9).

$$b_N(x) = \operatorname{argmin}_b \frac{1}{l} \sum_{i=1}^l (b(x_i) - s_i)^2, \quad (9)$$

where  $\{(x_i, s_i)\}_{i=1}^l$  – the sample on which the training is performed, the vector  $s$  – the vector of shifts (10).

$$s = -\nabla F = \begin{pmatrix} -L'_z(y_1, a_{N-1}(x_1)) \\ \dots \\ -L'_z(y_l, a_{N-1}(x_l)) \end{pmatrix}, \quad (10)$$

which should minimize the loss function (6) for each next algorithm.

At the stage of constructing the algorithm we will construct a classifier with the help of the freely distributed library of machine learning programming language Python – scikit-learn.

```
from sklearn.ensemble import GradientBoostingRegressor
```

```
boost = GradientBoostingRegressor(n_estimators=num,
    max_depth=d, random_state=42)
```

We perform the classifier training on training data, leaving 25% of the data as test data for model validation. In the cycle, we will consistently teach the algorithm on 100 decision trees, changing the depth of the trees, in order to empirically determine the optimal parameters of the model – the number of trees in the composition and their depth.

```
X_train, X_test, y_train, y_test = train_test_split(X, y,
    train_size=0.75, random_state = 42)
trees = np.array([5, 10, 15, 20, 30, 40, 50, 60, 70, 100])
depths = np.array([3, 5, 7, 10, 15, 22])
for d in depths:
    scores_train = []
    scores_test = []
    for num in trees:
        boost = GradientBoostingRegressor(
            n_estimators=num, max_depth=d,
            random_state=42).fit(X_train, y_train)
        scores_train.append(np.sqrt(mean_squared_error(
            y_train, boost.predict(X_train))))
        scores_test.append(np.sqrt(mean_squared_error(
            y_test, boost.predict(X_test))))
```

## 6 Software architecture and operation

### 6.1 Architecture

For the software being developed, client-server architecture was chosen, in which the client and server interact using the HTTP protocol. Data exchange within the framework of this protocol is performed according to the standard “request – response” scheme, which is the basis for transmitting data to the Internet [9]. HTTP encapsulates the entire process of serving web pages and provides the ability to specify a way to encode a message, so that the client and server can exchange binary data. Adaptive testing software has been developed taking into account the architectural style of REST, which was created on the basis of and together with HTTP. REST defines the restrictions on the use of HTTP, and describes a well-developed web application: reliable, properly working, and scalable, with a simple elegant design that can be easily changed [24].

In the process of developing web applications, the authors used the concept of separation of logical sections of code, which contributes to higher cohesion both in the initial development and in the constant support of any system. A clear distinction between client and server levels makes modular code sections easily manageable. In addition, the task was to clearly separate the data and display the markup of the site:

the data is not embedded in the page, but is delivered in a textual JSON data exchange format based on JavaScript. This is consistent with the modern concept of unobtrusive JavaScript, which separates the behavior, structure and presentation of the page.

Flexibility and code reuse is a logical result of good code organization. Flexibility exists at many stages of the application life cycle, when code sections can be developed in relative isolation (application programming interfaces (API), created clients of mobile devices, and new versions of program sections are released). The method of software development was chosen the scheme of separation of application data, user interface and control logic – MVC (Model – View – Controller). A key advantage of the MVC approach is that the components are loosely coupled. Each separate part of a web application running on the Django framework has a single key purpose and can be changed independently without affecting other parts. For example, a developer can change a URL for a specific part of a program without affecting the base implementation. A designer can change the HTML code of a page without touching the Python code that creates it. The database administrator can rename the database table and indicate changes in one place, and not search and replace multiple files [13].

## **6.2 Description of software operation**

In Fig. 2 shows a diagram of the system activity and the basic logic of the software, starting with the user's authorization, to the implementation of the adaptive testing function with the result output. After registration, the user is offered a survey to determine the individual characteristics of the person. Based on these data, the system selects tasks with an emphasis on a certain form of user perception.

At the output, the system offers the user a personal selection of questions of varying complexity and presentation form. The test is considered to be passed successfully, in the case when the subject reaches a set number of points. If the user has exhausted the limit of the number of questions in the test, without gaining the required number of points, the test is considered uncollected. The system takes into account how much time is spent on passing the test, as well as the fluctuation factor between answer choices, if the subject chose different answer choices before the final decision. On the basis of preliminary data on the level of completed tasks, the optimal level of the next question is predicted for a particular subject.

## **7 Results**

A database of test questions with different levels of complexity was developed for the discipline “Artificial Intelligence Systems”, which is taught for 7-8 semesters to bachelors in the specialty 121 – “Software Engineering”. The discipline consists of 5 informative modules and 19 thematic tests. Each test contains from 5 to 8 questions of two types: with one correct answer (one-alternative question) and several correct answers (multi-alternative).

Developed web-based software AdaptEd with an adaptive interface that allows applying testing in the discipline directly during lectures on students' mobile devices. AdaptEd system allows creating online courses of disciplines due to the fact that the



teacher can fill the system with lecture materials, additional materials, tasks for laboratory or practical work, test tasks, etc. Figure 3 show screenshots of AdaptEd at the stage of the entrance examinations of students and testing on the topic “Regression models” of the discipline “Artificial Intelligence Systems”. Each student can see the progress of testing success in the personal account of the system. At this time, organized pedagogical experiment, which should show the advantages of using adaptive testing to the standard one.

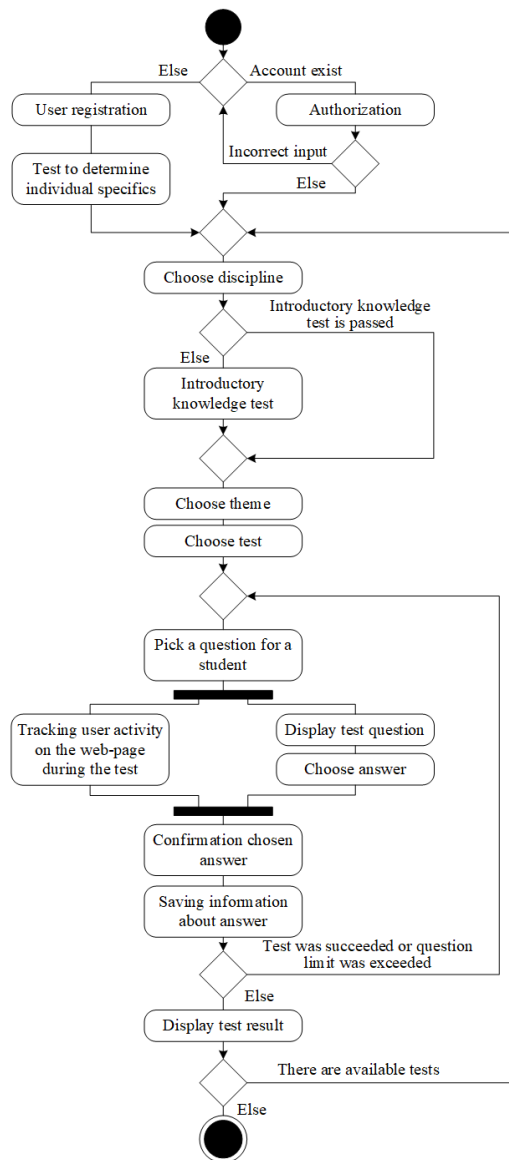


Fig. 2. System activity diagram

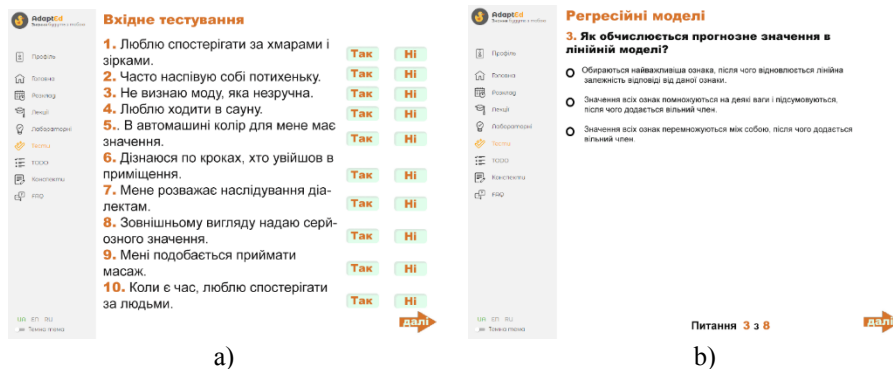


Fig. 3. a) Input testing. Definition of psychological type; b) Test for the topic “Regression Models” for the discipline “Artificial Intelligence Systems”

## 8 Conclusion

In the process of studying the problem of developing web-based software for an adaptive testing system for bachelors, the current state of using computer adaptive testing methods was analyzed, the choice of methods for implementing a knowledge quality control system was justified, taking into account individual student characteristics, a universal system for adaptive knowledge control was developed, and a complex was developed-oriented test tasks of different levels of complexity for the current and module control in the discipline “Artificial Intelligence Systems” for bachelors in the specialty 121 – “Software Engineering”.

The results of the study lead to the following conclusions:

1. Adaptive testing, based on the individual indicators of the subject, is an effective method of controlling the knowledge of students of higher educational establishment.
2. The implementation of adaptive knowledge testing should be carried out under conditions of systematic control, individualization by personality type and level of knowledge.
3. The software implementing the adaptive testing system should be in constant access for the subject, therefore the client-server interoperability model is implemented.
4. The database of test tasks must have enough of them for each level of complexity and be presented in a different form of information presentation.

The results of experimental use of the developed software for adaptive control of students’ knowledge in the discipline “Artificial Intelligence Systems” showed that the testing system should be supplemented with tasks with a detailed answer. In addition, it is desirable to expand the base of tests with tasks with imaginative and heuristic forms of knowledge representation. These comments define ways to further improve the developed system of adaptive quality control of knowledge:

- study the methodology and develop a mechanism for assessing the detailed response using the methods of dormant-semantic analysis;
- implement a software module that will provide the opportunity for the subject to demonstrate tasks with multimedia content.

## References

1. Amelkin, V.V.: Differential equations in Applications. Nauka, Moscow (1987)
2. Avanesov, V.S.: Difficulty of a Test and Testing Tasks. *Management of School*. 40 (1999)
3. Barbe, W.B., Milone M.N.: What we know about modality strengths. *Educational Leadership*. February, 378–380 (1981).
4. Bondarenko, M.F., Semenets, V.V., Belous, N.V., Kutsevich, I.V., Belous, I.A.: Assessment of Testing Tasks of Various Types and Their Complexity Determination. *Artificial Intelligence*. 4, 322–329. [http://www.foibg.com/ibs\\_isc/ibs-12/ibs-12-p07.pdf](http://www.foibg.com/ibs_isc/ibs-12/ibs-12-p07.pdf) (2009). Accessed 13 Feb 2019
5. Chelombitko, V.F., Mazhuga, M.O.: Use of Illustrative Materials for Creating Book and Electronic Multimedia Publications. *Bionics of Intelligence*. 1(86), 112–115 [http://openarchive.nure.ua/bitstream/document/4852/1/Chelombitko\\_VF\\_112-115.pdf](http://openarchive.nure.ua/bitstream/document/4852/1/Chelombitko_VF_112-115.pdf) (2016). Accessed 10 Feb 2019
6. Domingos, P., Pazzani, M.: On the Optimality of the Simple Bayesian Classifier under Zero-One Loss. *Machine Learning*. 29(2-3), 103–130 (1997). doi:10.1023/A:1007413511361
7. Flach, P.A.: *Machine Learning: The Art and Science of Algorithms that Make Sense of Data*. Cambridge University Press, Cambridge (2012)
8. Fleming, N.D., Mills C.: Not Another Inventory, Rather a Catalyst for Reflection. *To Improve the Academy*. 11, 137–149 (1992)
9. Forcier, J., Bissex, P., Chun, W.: *Python Web Development with Django*. Pearson Education, Boston (2008)
10. Garipova, Z.F.: Determination of the type of education material perception by Primary Students. In: *North of Russia: Development Strategies and Outlook, Surgut* (2016)
11. GOST: Data Organization in Data processing Systems. Terms and Definitions. GOST 20886-85.
12. Hodovaniuk, T.L.: *Idividual Training at Higher School*. NPU im. M. P. Drahomanova, Kyiv (2010)
13. Holovaty, A., Kaplan-Moss, J.: *The Definitive Guide to Django*. Apress, New York (2009)
14. Koltsov, Yu.V., Dobrovolskaya, N.Yu.: Neural Network Models in Adaptive Computer Learning. *Educational Technology & Society*. 5(2), 213–216 (2002)
15. Luo, F.L., Unbehauen, R.: *Applied Neural Networks for Signal Processing*. Cambridge University Press, Cambridge (1998)
16. Malygin, A.A.: Adaptive Testing of Students' Learning Results at Distant Learning. Abstract of Cand. Sci. (Pedagogy) Dissertation (2011)
17. Mazorchuk, M.S., Dobriak, V.S., Honcharova, K.A.: Model-Based Test Parameter Assessment. In: *International Scientific and Practical Conference "Problems and Outlooks of IT-Industry Development"*, pp. 123–125 (2010)
18. Perceptual Learning Style Preference Questionnaire <https://ru.scribd.com/document/258495684/Perceptual-Learning-Style-Preference-Questionnaire> (1984). Accessed 30 Jan 2019

19. Petrova, M.Ye., Mintii, M.M., Semerikov, S.O., Volkova, N.P.: Development of adaptive educational software on the topic of “Fractional Numbers” for students in grade 5. In: Kiv, A.E., Semerikov, S.O., Soloviev, V.N., Striuk, A.M. (eds.) Proceedings of the 1<sup>st</sup> Student Workshop on Computer Science & Software Engineering (CS&SE@SW 2018), Kryvyi Rih, Ukraine, November 30, 2018. CEUR Workshop Proceedings. **2292**, 162–192. <http://ceur-ws.org/Vol-2292/paper19.pdf> (2018). Accessed 21 Mar 2019
20. Principe, J.C., Euliano, N.R., Lefebvre, W.C.: Neural and Adaptive Systems. Fundamentals Through Simulations. John Wiley & Sons, New York (2000)
21. Rash, G.: Probabilistic models for some intelligence and attainment tests. University of Chicago Press, Chicago (1993)
22. Registry of the Information Intake style by A.R. Gregos. <http://psytests.org/cognitive/gregos.html>. Accessed 28 Jan 2019
23. Richert, W., Coelho, L.P.: Building Machine Learning Systems with Python. Packt Publishing, Birmingham (2016)
24. Saternos, C.: Client-Server Web Apps with JavaScript and Java: Rich, Scalable, and RESTful. O’Reilly Media, Sebastopol (2014)
25. Semerikov, S.O., Teplytskyi, I.O., Yechkalo, Yu.V., Kiv, A.E.: Computer Simulation of Neural Networks Using Spreadsheets: The Dawn of the Age of Camelot. In: Kiv, A.E., Soloviev, V.N. (eds.) Proceedings of the 1st International Workshop on Augmented Reality in Education (AREdu 2018), Kryvyi Rih, Ukraine, October 2, 2018. CEUR Workshop Proceedings. **2257**, 122–147. <http://ceur-ws.org/Vol-2257/paper14.pdf> (2018). Accessed 21 Mar 2019
26. Shapovalova, N.N., Rybalchenko, O.H. Kuropyatnyk, D.I.: Comparative Analysis of Methods of Optimizing the Functional Machine Learning Models Quality. Bulletin of Kryvyi Rih National University. **46**, 104–112 (2018)
27. Striuk, A.: Design of Educational Objects of Augmented Reality. Transactions. Georgian Technical University. Automated control systems. **2(26)**, 127–134. [http://gtu.ge/Journals/mas/Referat/N26\\_conf\\_unesco\\_2018\\_2\\_26.pdf](http://gtu.ge/Journals/mas/Referat/N26_conf_unesco_2018_2_26.pdf) (2018). Accessed 29 Oct 2018
28. Sviridenko, O.M.: Use of the Specific Character of Representative Systems of Students for Successful Information Uptake. Bulletin of National Aviation University, Pedagogy, Psychology. **1** (2009)
29. Syrovatskyi, O.V., Semerikov, S.O., Modlo, Ye.O., Yechkalo, Yu.V., Zelinska, S.O.: Augmented reality software design for educational purposes. In: Kiv, A.E., Semerikov, S.O., Soloviev, V.N., Striuk, A.M. (eds.) Proceedings of the 1<sup>st</sup> Student Workshop on Computer Science & Software Engineering (CS&SE@SW 2018), Kryvyi Rih, Ukraine, November 30, 2018. CEUR Workshop Proceedings. **2292**, 193–225. <http://ceur-ws.org/Vol-2292/paper20.pdf> (2018). Accessed 21 Mar 2019
30. Wulansari, Y.: The Use of Visual Auditory Kinesthetic (VAK) Learning Model to Improve Students’ Reading Comprehension: Graduating Paper. State Institute for Islamic Studies, Salatiga (2016)
31. Yefremtsev, S.: Diagnostics of Dominant Perceptive Modality. In: Fetiskin, N.P., Kozlov, V.V., Manuilov, G.M.: Social and Psychological Diagnostics of development of a person and small groups, pp. 237–238. <https://psycabi.net/testy/289-test-audial-vizual-kinestetik-dagnostika-dominiruyushchej-pertseptivnoj-modalnosti-s-efremtseva> (2002). Accessed 25 Jan 2019
32. Zahrebelnyi, S.L., Brus, M.V.: Adaptive Testing as a Means of Students’ Knowledge Control at Technical Higher Educational Institutions. DHMA Bulletin. **1(22)**, 155–162 (2017)

# Intelligent Adaptation Method for Human-Machine Interaction in Modular E-Learning Systems

Evgeniy Lavrov

Sumy State University, Sumy, Ukraine  
prof\_lavrov@hotmail.com

Olga Lavrova

Taras Shevchenko National University of Kyiv, Kiev, Ukraine  
lavrova\_olia@ukr.net

**Abstract.** The article describes ergonomic problems in e-learning systems. A new method for ensuring ergonomics of electronic educational resources, including ergonomic expertise and multilevel adaptation to the capabilities of trainees was developed. A model approach based on an anthropocentric concept is proposed, which takes into account the requirements of system analysis for the e-learning system as a man-machine complex, namely: multivariance and detailing of the functional structures of the dialogue man-machine interaction in the learning process; parameters, preferences and conditions for individual operators working with the system; the possibility of dynamic optimization of human-machine interaction in real time, providing mechanisms for multi-level adaptation to the human operator.

**Keywords:** Ergonomics, E-learning, An algorithm of activity, Optimization of activities, Human factor, Human-machine, Effectiveness

## 1 Introduction

The widespread introduction of computer technology into all spheres of human activity radically changed their nature. Revolutionary changes have taken place not only in industry, agriculture and science but also in the education system. Computerization of the acquisition of knowledge and skills has affected many forms of education (in schools, universities, industrial enterprises, commercial firms, self-training, retraining, advanced training, etc.). The progress of technical facilities and new technological opportunities have caused a surge of interest in new computerized tools and methods of training. In recent years a new progressive concept of “lifelong learning” has emerged and spread widely [1].

E-learning has evolved through a number of stages – from the “use of technical tools for instruction” to the use of modern distributed educational environments of universities (for example [2, 3]) in the educational process, using mobile devices [4, 5]. In universities, “online” and “blended” learning technologies are widely used [6, 7].

At the same time, huge resources and incredible efforts of teams of IT specialists, teachers, and scientists are spent to create learning technologies of a new type [3].

There has been, indeed, enormous progress in enriching the educational process with new methods of training using technical and electronic means. However, according to some estimates [8, 9], the results of cognitive activity of trainees in the learning process do not quite meet the expectations of leading specialists.

The practice of a number of universities shows that trainees cannot fully interact with non-adaptive learning systems that do not meet the modern educational needs and expectations of trainees. Even the most advanced technologies and devices introduced into the learning process haphazardly can lead to a decrease in the efficiency of cognitive activity, and sometimes to the complete failure of the idea of computerization of education. Some aspects of such problems have been analyzed in [9, 10].

Even the problems of harmfulness of e-learning and new threats to humans arising in connection with the peculiarities of new information technologies are discussed [1-9].

Thus, the practice of using e-learning tools faced the need to search for ergonomic reserves to enhance the effectiveness of e-learning methodology and the wider use of modern SMART technologies.

Progress and strong competition in providing information and computer services for legal entities and individuals in local and global networks exacerbate problems of quality and operational services. Huge efficiency reserves are in the modern arsenal of ergonomics methods [1-6].

## **2 Literature Review and Problem Statement**

It is obvious that as automated information systems become more sophisticated in the complex of general measures aimed at increasing the efficiency of the learning process, the need for ergonomic measures and tools also increases [12-17]. Ergonomic quality management programs [12] are designed not only to improve reliability [17] and usability [13], to ensure optimal working conditions for operators [14] but also to reduce the likelihood of stress [12] and threats to human health [14, 15].

Over the past years, in addition to the existing classical ergonomic approaches, new techniques have been developed in these respects:

- designing working conditions at the operator's workplaces [22, 23];
- ergonomic expertise [10-12];
- designing algorithms for human-machine interaction [19-25];
- distribution of functions between operators [24, 25];
- optimization of group activities [17, 24];
- forecasting error-free operation of operators and the risks of losses from unreliability [12];
- others (briefly described in [12, 13]).

Many of these methods are appropriate to use in designing and running e-learning systems as classical "man-technology-environment" systems [30, 31].

However, the specifics of e-learning systems as a special “person-technology-environment” system, the elements of which differ from other types of systems, should be noted [1, 2, 23]:

- subject of labor – information (educational content);
- tools of labor – software and hardware for the delivery of educational content;
- product of labor – a new state of the trainee – the human operator (new knowledge and skills);
- system of performance evaluation – through indicators of the likelihood of achieving specified levels of knowledge and skills (using the specified resources and environmental characteristics) and the degree of compliance of use and interaction with the “students’ expectations”.

The presence of such special elements of the system requires special methods to ensure ergonomic quality [18-19], as well as the introduction of modern SMART technologies.

A systems analysis of the problems of human-machine interaction in university learning environments, approaches to finding ergonomic reserves for increasing efficiency and requirements for appropriate methods was carried out in [20, 23].

In this regard, the purpose of this work is: to describe the concept and system of methods necessary to ensure the ergonomic quality of e-learning.

### **3 Results**

#### **3.1 Sample of Main Tasks for Improving E-Learning**

To determine the need for research, interviews were conducted among students [35] who study using electronic educational environment of the university.

Very often a student gives up his studies because “he does not get what he expects from the system”. This applies to local systems, and especially to distance learning systems.

The main complaint of students to the existing means of e-learning (ergonomic defects) are:

- complexity and inflexibility of manipulating learning technology (34.3%);
- low conformity of information modality to styles and ways of user perception (21.1%);
- limited ability to change complexity (12.4%);
- difficulty of predicting learning outcomes (11.1%);
- poor adaptability for work with mobile devices (10.9%);
- lack of self-test technology and explanatory component (7.1%);
- others (3.1%).

The results of the studies confirm the thesis that a dialogue based system is effective only when it provides what the user expects from it, which explains the need for transition in the learning process to new adaptive technologies of human-machine interaction.

### **3.2 The Basic Concept. Justification of Requirements for Research Methods. Simulation of Human-Computer Interaction Analysis**

The following variants of the concept of the relationships between the “man” and “technology” elements are formulated in relation to the concept of “system”:

- system-technical approach – the system is considered as consisting only of technical elements, and the person is considered as a factor in the environment;
- equal element approach – the system is considered as consisting of the equivalent “man” and “technology” elements;
- human-system approach – a person is the main element of the system, whereas technology is the “means of labor” subordinate to him;
- narrow anthropocentric approach – the system is considered as consisting only of the “man” elements without taking into account the “technology” elements;
- narrow technical approach – the system is considered as consisting of technical elements, and the person is not taken into account.

It is obvious that for the tasks of this research, it is necessary to focus on the human-system approach.

Within the framework of this concept, a functional-structural theory (FST) was created to describe the process of functioning and the evaluation of efficiency, quality, and reliability of functioning on its basis. The process of functioning is supposed to mean “the aggregate of actions of ergatic elements and operations performed by non-ergatic elements, united in a single purposeful sequence due to the managing and supporting activity of ergatic elements that form a coherent logical-temporal sequence from the disconnected nomenclature of individual functions that is stable to disturbances and leads to the achievement of the specified goal (or goals) of functioning”.

General requirements to mathematical models of the working process are formulated as follows:

- the model should cover both the main and auxiliary working processes of the “man-technology-environment” system;
- the choice of level of the description language of the working process must correspond to the semantic level of the simulated processes;
- the language should be sufficiently formalized for unambiguous perception on the computer;
- the model should combine the capabilities to describe and evaluate the working process;
- the alphabet of the language describing the working processes of the “man-technology-environment” system should consist of functional elements and be as simple as necessary, but capable to describe specific features of all sub processes of the working process.

In the works on ergonomic design, a systematic approach is adopted to determine the range of indicators of the workflow, according to which the resulting ergonomic quality



is efficiency, i.e. ability of the system to reach the ultimate goal, i.e. to get a product of specified quality under given conditions.

The processes of dialogue based interaction in e-learning system can be described by a number of formal systems:

- logical systems (formal grammars, Petri nets, logical automata, event algebras, logical schemes of algorithms, etc.);
- algebraic systems (Markovian and semi-Markov processes, semi-Markovian service networks, etc.);
- language-algebraic systems (networks of precedence, PERT, GERT, MKP networks, functional networks).

Comparative analysis of main methods of describing and evaluating the dialogue based interaction in the e-learning system gives the opportunity to conclude that the concept of SMART systems, the methodology of intelligent data analysis and the apparatus of functional networks are to the greatest extent consistent with the requirements of this study [17-19].

The most convenient algorithmic activity modeling way is functional-structural theory (FST) of ergotechnical systems (ETS) by A. I. Gubinsky [17]. The description of elementary actions of operators is carried out with the help of standard functional units (TFU). A complete list of TFU is given in [17]. The functional network (FN) that describes the activity of the human-operator is built from these TFU. Mathematical models for accurateness and run-time estimation are obtained for typical functional structures (TFS). These models are used to evaluate the entire FN. The estimation is carried out by the method of folding (reduction) FN [17].

### **3.3 Justification of the Need for a Model Approach**

The model approach based on an anthropocentric concept is proposed, which takes into account:

- the requirements of a system analysis of the e-learning system as a human-machine complex;
- multivariance and details of functional structures of dialogue based human-machine interaction in the learning process;
- parameters, preferences and conditions of particular operators working with the system;
- possibility of dynamic optimization of human-machine interaction in real time, providing mechanisms for multi-level adaptation to the human operator.

### **3.4 Approach to the Organization of Intelligent Agents for E-Learning. The Method of Multi-Level Adaptation**

Adaptability problems of modern technologies and computer-based training methods [20, 23], namely limited adaptability to individual characteristics and educational needs of trainees are to be addressed in this study by:

- creation of a system of ergonomic certification of e-learning modules for computer training systems [20, 25];
- introduction of special intelligent agents-managers [20, 23], intended for mechanisms of multilevel adaptation of teaching aids to individual cognitive features of a trainee.

Among the capabilities of such intelligent agents, it is necessary to provide [20, 23]:

1. choice of the optimal modality (the form of presentation of educational information), convenient for a specific person (provides the maximization of cognitive comfort).
2. operative correction of the recommended algorithms of human-machine interaction, taking into account:
  - functional state of a trainee;
  - his motivation;
  - his preparedness;
  - details of technical and software tools, time and other resources available;
  - interactive capabilities of an electronic module;
  - current self-test results;
  - etc.

### **3.5 General Description of the Structure of Research in the Field of Ergonomic E-Learning Support**

The development of the method and information technology of the intelligent adaptation of human-machine interaction in modular e-learning systems involves solving the following specific tasks that we solve:

- development of a technique and models of ergonomic expertise of electronic training modules used in the formation of the bases of educational resources of the educational environment of the university;
- development of a technique and models for the analysis of e-learning systems as human-machine complexes to form databases and knowledge systems required for information support of problems of intelligent adaptation of human-machine interaction;
- development of a technique and models for formal description of options for organizing human-computer interaction in the process of e-learning;
- development of a technique and models for evaluating the effectiveness of dialogue based interaction in modular e-learning systems, taking into account the characteristics of the human operator, the characteristics of the system and the characteristics of the environment;
- development of a multilevel adaptation method in modular e-learning systems, including mechanisms for selecting the optimal modality of electronic modules and constructing individual learning paths depending on the environment, as well as motivation, psychophysiological features, preparedness and condition of the trainee;

- development of information technology elements for the ergonomic provision of human operator activities in modular e-learning systems;
- approbation of technology and evaluation of the effectiveness of the method.

For the conditions of a particular university, these studies must be adjusted.

### 3.6 The Using of Information Technology. Approbation. Implementation

Based on the proposed methods, an information technology for managing e-learning has been developed. It includes:

- University Management Information System;
- information system for ergonomic expertise of electronic training modules;
- intelligent agent manager to manage the dialogue;
- and others.

Demonstration of ideas for an intelligent agent is shown in Fig. 1.

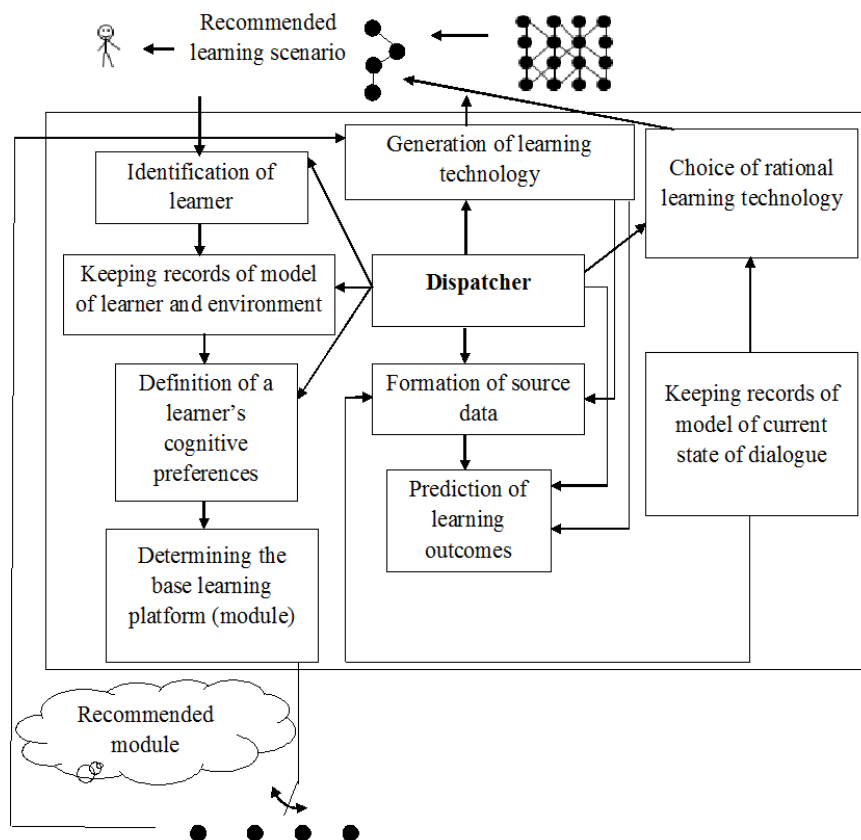


Fig. 1. Basic functional blocks and principle of agent-manager functioning for e-learning

The results were embedded in:

- Lomonosov Moscow State University,
- Belgorod Agrarian Academy,
- Sumy National Agrarian University,
- Sumy State University;
- Vinnytsia State Agrarian University,
- Kremenchug State Technical University,
- Ukrainian Engineering and Pedagogical Academy (Kharkov),
- Kharkiv National University of Municipal Economy,
- and other universities.

The intelligent agent-manager has the ability to integrate into any distance education management system.

### **3.7 The Effectiveness**

Testing the effectiveness of ideas and methods was carried out for two types of distance education management systems:

- standard (for example, Moodle);
- unique university systems.

In both cases, the use of our ideas can significantly increase the adaptability of educational technologies.

Let's describe the effectiveness of the method for only one university – Sumy National Agrarian University, Ukraine (Experiments and efficiency analysis were carried out by N. Barchenko during the dissertation research (2015-2019) [26]).

The use of the agent-manager allowed the experimental group (the experiment was conducted [20, 26] under the guidance of N. Barchenko, S. Agadzhanova, N. Pasko, A. Tolbatov):

- to raise the average score from 72.32 to 81.43;
- to reduce the percentage of refusal to work with e-learning from 24.78% to 7.29%.

The results of the implementation of the system of ergonomic expertise in Sumy National Agrarian University (according to the data of N. Barchenko [20, 26]):

- the percentage of certified electronic modules increased from 5 to 85.4.
- the quality assessment of electronic modules (student survey - on a 100-point scale) increased from 37.7 to 83.8.

## **4 Conclusion**

We have developed:

- a new method for ensuring the ergonomics of electronic educational resources, including ergonomic expertise and multilevel adaptation to the capabilities of trainees;
- elements of information technology to manage interaction in modular e-learning systems.

The obtained results contribute to the development of new SMART technologies and models of adaptive management of the electronic education system and enable the transition to the technologies of dialogue based interaction of a new generation. The social effect consists in a significant increase in the cognitive effectiveness and attractiveness of e-learning technologies. The economic effect is determined by the possibility to reach the following goals:

- improving quality of educational and cognitive activity;
- attracting categories and increasing the number of trainees.
- accessing new international markets for educational services.

The scientific novelty of the results is that, in contrast to the known results obtained earlier:

- in the general theory of adaptive control systems (A.I. Rastrigin, etc.), where in general a person is excluded from the review process;
- in the transformational learning theory (V.F. Venda, etc.), the theory of ergonomic provision of transport systems (E.V. Gavrilov, V.K. Dolya) and studies of many other scientific schools that do not provide the construction of functional models of human-computer interaction variants;
- in the framework of the functional-structural theory of ergotechnical systems of the scientific school, formed by A.I. Gubinsky, in which until now:
  - the task of adapting the information learning system to the human operator is not fully formulated;
  - the models of evaluation and optimization are oriented on an “average” operator;
  - a model of the human-computer information training system has not been built.

## References

1. Blaschke, L.M.: Heutagogy and lifelong learning: A review of heutagogical practice and self-determined learning. *The International Review of Research in Open and Distance Learning* 13(1), 56–71 (2015)
2. Cochrane, T., Narayan, V., Oldfield, J.: iPadagogy: Appropriating the iPad within pedagogical contexts. *International Journal of Mobile Learning and Organisation*. 7(1), 48–65 (2013)
3. Joshua, D.: E-Learning platform system for the department of library and information science, Modibbo Adama University of Technology, Yola: A Developmental plan. *Information Impact*. 7(1), 51–69 (2016)
4. Pereira, O.R.E., Rodrigues, J.J.P.C.: Survey and analysis of current mobile learning applications and technologies. *ACM Computing Surveys (CSUR)*. 46(2), 27 (2013)

5. Al-Qahtani, A.A.Y., Higgins, S.E.: Effects of traditional, blended and e-learning on students' achievement in higher education. *Journal of Computer Assisted Learning*. **29**(3), 220–234 (2013)
6. Verkhova, G.V., Akimov, S.V.: Electronic educational complex for training specialists in the field of technical systems management. In: *IEEE II International Conference on Control in Technical Systems (CTS)*, pp. 26–29 (2017)
7. Semingson, P., Crosslin, M., Dellinger, J.: Microlearning as a tool to engage students in online and blended learning. In: *Society for Information Technology & Teacher Education International Conference*, pp. 474–479 (2015)
8. Ashraf, A., El-Bakry, H., Samir Abd El-razek, M.: Handling big data in e-Learning. *International Journal of Advanced Research in Computer Science & Technology*. **3**(1), 47–51 (2015)
9. Anokhin, A., Ivkin, A.: Evaluation of ecological interface design for supporting cognitive activity of nuclear plant operators. In: *Proceedings of the International Conference in Applied Human Factors and Ergonomics 2014 and the Affiliated Conferences*, pp. 260–270 (2014)
10. Lavrov, E., Kuppenko, O., Lavryk, T., Barchenko, N.: Organizational approach to the ergonomic examination of e-learning modules. *Informatics in Education*. **12**(1), 105–123 (2013)
11. Burov, O., Tsarik, O.: Combination of usability evaluation of e-learning tools and ergonomic expertise. *Proceedings of the National Aviation University*. **2**(59), 136–140 (2013)
12. Havlikova, M., Bradac, Z., Jirglb, M.: Human reliability in man-machine systems. *Procedia Engineering*. **100**, 1207–1214 (2015). doi:10.1016/j.proeng.2015.01.485
13. Haji Hosseini, A.R., Jafari, M.J., Mehrabi, Y., Halwani, G.H., Ahmadi, A.: Factors influencing human errors during work permit issuance by the electric power transmission network operators. *Indian Journal of Science & Technology*. **5**(8), 3169–3242 (2012)
14. Rothmorea, P., Aylwardb, P., Karnon, J.: The implementation of ergonomics advice and the stage of change approach. *Applied Ergonomics*. **51**, 370–376 (2015). doi:10.1016/j.apergo.2015.06.013
15. Dul, J., Bruder, R., Buckle, P., Carayon, P., Falzon, P., Marraset, W.S.: A strategy for human factors/ergonomics: developing the discipline and profession. *Ergonomics*. **55**(4), 377–395 (2012). doi: 10.1080/00140139.2012.661087
16. Cacciabue, P.C.: Human error risk management for engineering systems: a methodology for design, safety assessment, accident investigation and training. *Reliability Engineering & System Safety*. **83**(2), 229–269 (2014). doi:10.1016/j.ress.2003.09.013
17. Adamenko, A.N., et al.: *Informatsionnye upravlyayushchye cheloveko-mashynnye sistemy issledovaniya, proektyrovaniya, testirovaniya (Information controlling human-machine systems: research, design, and testing)*. In: Gubinsky, A.I., Evgrafov, V.G. (eds.) Reference Book, Mashinostroyeniye, Moscow (1993)
18. Chabanenko P.P.: *Issledovanie bezopasnosti i effektivnosti funktsionirovaniya sistem chelovek-tehnika ergosetyami (Study of the safety and efficiency of the functioning of man-machine systems of ergo networks)*. Izd-vo akad. voen.-mor. sil im. P.S. Nahimova, Sebastopol (2012).
19. Grif M. G., Sundui, O., Tsoy, E. B.: Methods of designing and modeling of man-machine systems. In: *Proceedings of International Summer workshop Computer Science 2014*, pp. 38–40 (2014).
20. Lavrov, E., Pasko, N., Barchenko, N., Tolbatov, A.: Development of adaptation technologies to man-operator in distributed E-learning system. In: *Proceedings of the 2nd International*

- Conference on Advanced Information and Communication Technologies, AICT 2017, 29 August 2017, pp. 88–91 (2017)
21. Lavrov, E., Pasko, N., Krivodub, A., Barchenko, N., Kontsevich, V.: Ergonomics of IT outsourcing. Development of a mathematical model to distribute functions among operators. *Eastern European Journal of Enterprise Technologies*. **4**(80), 32–40 (2016). doi:10.15587/1729-4061.2016.66021
  22. Lavrov, E., Pasko, N., Tolbatov, A., Tolbatov, V.: Ergonomic reserves for improving reliability of data processing in distributed banking systems. In: *Proceedings of the 2nd International Conference on Advanced Information and Communication Technologies-2017 (AICT-2017)*, Lviv, Ukraine, pp. 79–82 (2017)
  23. Lavrov, E., Barchenko, N., Pasko, N., Borozenec, I.: Development of models for the formalized description of modular e-learning systems for the problems on providing ergonomic quality of human-computer interaction. *Eastern-European Journal of Enterprise Technologies*. Ser. Information Technology. **2**(2/86), 4–13. doi:10.15587/1729-4061.2017.97718 (2017)
  24. Lavrov, E., Pasko, N., Krivodub, A., Tolbatov, A.: Mathematical models for the distribution of functions between the operators of the computer-integrated flexible manufacturing systems. In: *Proceedings of the 8th International Conference TCSET'2016 "Modern Problems of Radio Engineering, Telecommunications, and Computer Science"*, Lviv-Slavsko, Ukraine, pp. 72–76 (2016)
  25. Lavrov, E., Pasko, N., Tolbatov, A., Tolbatov, A.: Cybersecurity of distributed information systems. The minimization of damage caused by errors of operators during group activity. In: *Proceedings of the 2nd International Conference on Advanced Information and Communication Technologies-2017 (AICT-2017)*, Lviv, Ukraine, pp. 83–87 (2017)
  26. Barchenko N.L.: Erhonomichne zabezpechennia dialohovoi liudyno-mashynnoi vzaiemodii v modulnykh systemakh elektronoho navchannia (Ergonomic support for human-machine interaction in modular learning systems) Dissertation, Kharkiv National University of Urban Economy (2019)

# Historical Approach to Modern Learning Environment

Aleksander Spivakovsky<sup>[000-0001-7574-4133]</sup>, Lyubov Petukhova<sup>[0000-0003-0814-2807]</sup>,  
Vira Kotkova<sup>[0000-0002-1537-0923]</sup> and Yuriy Yurchuk<sup>[0000-0002-1022-7079]</sup>

Kherson State University, 27, Uninersytetska Str., Kherson, 73000, Ukraine  
{spivakovsky, petuhova, veras, yurchuk}@ksu.ks.ua

**Abstract.** The article is devoted to review system-organizing approaches and the development trends to the learning environment. Learning environment is explored according to the used information technology. Six stages of learning environment development are described. The transformation of the term ‘technology in education’ to ‘pedagogical technology’ is analyzed according its changes in content. The relationship between e-learning, Information Technology (IT) and Information and Communication Technologies (ICT) is identified. E-learning is understood as an umbrella term that covers web-based instruction, online learning, networked learning, computer-assisted learning and computer-mediated learning. The comparative characteristics of traditional and e-learning are made. Three levels (1.0, 2.0, 3.0) of the Web are analyzed. The quantitative results of the survey asked about the type of e-learning institutions use are presented. Eight trends of e-learning industry for 2019 are described. It is pointed out that the future development of technology will change the delivery modes used, the cost effectiveness and the acceptance and recognition of the new learning environment.

**Keywords:** Learning environment, information and learning technologies, e-learning, blended learning.

## 1 Introduction

Educational process is changing due to the evolution of the society all the time. Now we are witnesses of higher education transformation and adaption of student’s workplace for various forms of using traditional and ICT learning tools. The advances of digital multi-tools provide wide access to various kinds of information sources, widening the walls of the educational institution.

Until recently, higher education e-learning has attracted remarkably little attention beyond the bounds of its dedicated communities and projects. For example, it has not been prominent in Bologna Process discussions and only became a focal point of EU education policy in September 2013, with the publication of the ‘Opening up Education’ Communication by the European Commission [5].

According to the 2030 Agenda for Sustainable Development announced in 2015 Sustainable Development Goal 4, known as Education 2030, is a single global goal for quality education, which aims to ensure inclusive and equitable quality education



and promote lifelong learning opportunities for all. Technology is a fundamental driver of that vision to create equitable, dynamic, accountable and sustainable learner-centered digital learning ecosystems that are relevant for the 21st Century. Rapid advances in technology are revolutionizing the way in which teaching and learning is conceptualized, designed, and implemented in higher education. These developments play a key role in delivering quality education for all [10].

Our ability to develop skilled workers, build competitive advantages as nations and generate growth is provided with the knowledge economy. Such invest in for children via the schools system and right through to higher education and on-going, professional development and training is a fundamental support to the rest of our economic lives. To keep developing the knowledge economy we need to ensure, as with other sectors, that we maintain a level of innovation to improve the efficacy and efficiency of our learning systems. This is the importance of EdTech [17].

EdTech or EduTech, being a shorten form for Educational technology, is a wide field. Therefore, one can find many definitions, some of which are conflicting. We consider EdTech as the practice of introducing technologies and non-standard solutions to education for better learning. In 2017, investments in the EdTech market in the world grew to a record \$ 9.5 billion. And it is forecasted that by 2020 this mark will cross \$ 252 billion [8].

What started as an experiment in education delivery is now being transformed by a new breed of technology entrepreneurs. Moreover EdTech is about applying digital technology to deliver a new form of learning architecture. An architecture that harnesses the social reach of the internet, that delivers personalized learning and training that can automatically adjust to an individual's learning competence and that uses big data analysis to understand the most effective ways for learners to progress. In changing the traditional architecture of education, EdTech has the power to create efficiencies, cut costs and enable new levels of standardization and democratized access. It is set to transform the future of how education is resourced, taught, consumed and, ultimately, the results that it can then yield – both for the individual and for society as a whole as we continue to build the knowledge economy [17].

That's why today teachers are allowed to create an interactive learning environment. The attention should be paid to modelling systems in education in accordance with ICT evolution from a learning tool to the educational technology. Such development can be easily explained within triangle Student – Teacher – Learning Environment.

In the previous publication we made the review of didactic model transformation. We proved the transformation of modern didactic model into three-subject one – Student – Teacher – Information and communication pedagogical environment (ICPE). It was made as a result of ICPE active components analyses, description of the requirements set to ICPE as an educational subject, comparative analyses of characteristic components of traditional and innovative teaching system, modelling subjects' behaviour at different training forms according to subject-subject or three-subject didactic system. The measurement of each three educational subjects' cogency and their significance in the process of major study operations (collection, processing, storage, transmission) at various training forms as lecture, practice and individual

work was presented [14].

The article aims to trace the development of learning environment and to predict its future. This is important to teachers, who should now share such learning environment in which a person could fully develop his or her creative potential, develop abilities, and cultivate the need for continuous self-improvement and responsibility for own upbringing and development.

According to The National Council of Teachers of English, active, successful participants in this 21st century global society must be able to:

- develop proficiency and fluency with the tools of technology;
- build intentional cross-cultural connections and relationships with others so to pose and solve problems collaboratively and strengthen independent thought;
- design and share information for global communities to meet a variety of purposes;
- manage, analyze and synthesize multiple streams of simultaneous information;
- create, critique, analyze and evaluate multimedia texts;
- attend to the ethical responsibilities required by these complex environments [16].

The state of modern education and the development trends of society require new system-organizing approaches to the development of the educational environment.

## **2 Development of learning environment**

The informational and educational environment is a systemically organized set of data transmission means, information resources, interaction protocols, hardware-software and organizational-methodical support, focused on meeting the needs of users for information services and educational resources.

Developing a total learning environment for students in a particular course or program is probably the most creative part of teaching. While there is a tendency to focus on either physical institutional learning environments (such as classrooms, lecture theatres and labs), or on the technologies used to create online personal learning environments (PLEs), learning environments are broader than just these physical components. It also include:

- the characteristics of the learners;
- the goals for teaching and learning;
- the activities that will best support learning;
- the assessment strategies that will best measure and drive learning
- the culture that infuses the learning environment.

Learning environment is used to be concerned with the information technology, as the technology for people to work with information. According to this approach there are 6 stages of learning environment development.

The 1-st stage (up to the second half of XIX century) was 'Hand' information technology, its tools were pen, ink pot, book. Communications were carried out in a handy way by sending information with mailing lists, packages, dispatches. The main

aim of the information technology was to provide information in necessary form.

The 2-nd stage (since the end of XIX century) was ‘Mechanical’ technology; its tools for delivering information were typewriters, telephone, and voice recorder. The main aim of the information technology was to provide information in necessary form in the most convenient way.

The 3-rd stage (40-60 of XX century) was ‘Electric’ technology; its tools were developed to electric typewriters, Xeroxes, portable Dictaphones. The emphasis of information technology started to move from the form of information presentation to making its content.

The 4-th stage (since the beginning of 70-s) was ‘Electronic’ technology, its tools were EOM and created on their basis automated control systems (ACS) and information retrieval systems, equipped with a wide range of basic and specialized software complexes.

The 5-th stage (from the middle of the 80-s) was ‘Computer’ (New) technology, the main tool of which is a personal computer with a wide range of standard software products of various purposes. At this stage there was the process of personalization of the ACS, which manifests itself in the creation of decision support systems by certain specialists.

The 6-th stage (now developing) is ‘Network’ technology (sometimes it is considered as a part of computer technology). Global and local computer networks are beginning to be widely used in various industries.

The transformation of the term ‘technology in education’ to ‘pedagogical technology’ corresponds to a change in its content, covering the following three periods.

The first period (40s – mid-50s) is characterized by the emergence of a variety of technical means of presenting information – recording and reproduction of sound and projection of images, united by the concept of ‘audiovisual means’. The term ‘technology in learning’ meant the application of engineering knowledge in the learning process.

The second period (mid 50s-60s) introduction of technological approach is marked by the emergence of programmed training. Audiovisual means specially designed for educational purposes were developed: means of feedback, electronic classes, educational machines, linguaphone rooms, simulators, etc. Unlike the term ‘technology learning’, the same term ‘technical means of learning’, under the ‘technology of education’ meant a scientific description (a set of tools and methods) of the pedagogical process, which inevitably leads to the planned result.

For the third period (70s), three features are characteristic. First, there is an expansion of the pedagogical technology base. In addition to audiovisual education and programmable learning, the foundation of pedagogical technology was built on computer science, telecommunications theory, pedagogical qualimetry, system analysis and pedagogical sciences (psychology of teaching, theory of management of cognitive activity, organization of educational process, scientific organization of pedagogical work). Secondly, the methodical basis of pedagogical technology is changing, the transition from verbal to audiovisual training is carried out. Thirdly, the training of professional technology educators is beginning to be actively pursued [13].

Thus, pedagogical technology reflects the tactics of the implementation of educational technologies and is based on the knowledge of the regularities of the functioning of the system ‘Teacher – Environment – Student’ in certain study conditions (individual, group, collective, mass, etc.), it shares the common features and regularities of the educational process independently from a particular educational subject.

D. Charrisony and S. Nipper first used the term ‘generation’ to refer to three stages of e-learning development, ‘historically related to the development of production, transport and communication technologies’ [12].

Table 1 presents a brief description of three generations of e-learning.

**Table 1.** Generations (stages) of e-learning development

Generation	Technologies	Student’s activities	Learning mode	Training content	Teacher’s role
Cognitive behaviourism	Television, radio, print, face-to-face communications	Reading and reviewing materials	Individual training	Developed ‘from scratch’	Creator of the content
Constructivism	Audio, video and web conferencing	Discussion, development, design	Learning in groups	Constructed and developed by a teacher	Head of the discussion
Connectivism	Web 2.0: social networking, association of users	Research, connection, creation, evaluation	Network learning	Autonomic	Friend that critically evaluates

According to Table 1 each direction of pedagogy of distance education is characterized by certain features of social, cognitive component in the process of distance learning.

The first generation – ‘cognitive behaviourism’ – emphasizes the need to use the model of distance learning, the goals of which are clearly defined, formulated and exist separately from the students and the content of learning. The training material should be constructed in such a way as to maximize the effectiveness of mental activity. This generation is characterized by the absence of a ‘social’ in the process of learning. Study is considered as an individual process. A similar emphasis on individualized learning improves students’ autonomy. Preferably such technologies as radio, television, postal correspondence [periods] are used. The presence of a teacher in the learning process is extremely limited. The role of the teacher is mainly in the preparation of printed material. Later, students could see and hear the teacher through audio, video, multimedia technology.

Instead, ‘constructivism’ as the next generation comes, the main principles of which are the following features:

- new knowledge is built on the basis of prior knowledge;
- distance learning is considered as an active rather than passive process;
- language and other social tools play a role in building knowledge;
- the purpose of cognition and evaluation is a means of developing students' abilities

- to self-assess knowledge;
- the student is the core of the learning environment;
- it is necessary that the knowledge acquired in the process of distance learning is subjected to discussion by the community, verification and real use [12].

The teacher in this case is a mentor, assistant and partner, and the content of the teaching material becomes secondary to the learning process. Teacher and his experience are still the main sources of knowledge.

The next generation of pedagogy of distance education – ‘connectivism’ – involves unlimited access to network technologies. According to this approach, the role of the student is not to remember all the information, but to be able to find information and apply knowledge where necessary. For training with the use of distance learning technologies, students need to have a high level of information and communication competence, therefore, the primary task is to prepare students for learning with the use of special learning technologies. Teachers and students can collaborate in content development, offer ideas for improving teaching technology. The entire distance learning process is carried out on the basis of cooperation. However, this direction is characterized by the lack of pedagogical control, the structuring of educational content.

T. Anderson and D. Dron believe that each of the generations has its advantages and disadvantages. Future generation of distance learning, according to scientists, will be more subject-oriented, characterized by an increase in student activity in the learning process, learning virtualization [2].

Today we can speak about information and learning technology, that is a collection of fundamentally new tools and methods for processing data that ensure the purposeful creation, transmission, storage, and display of an information product, with the least possible cost, in accordance with the laws of the social environment in which the new information technology develops.

Generally, e-learning has been used to describe learning that is supported by technologies through various types of delivery modes.

Since 2002, e-learning has become an umbrella term that covers web-based instruction, online learning, networked learning, computer-assisted learning and computer-mediated learning [11]. All of these terms refer to the use of information and communications technologies in learning. The relationship between e-learning, Information Technology (IT) and Information and Communication Technologies (ICT) is identified in the eclipse diagram by Markos Tiris. Figure 1 shows that e-learning is based on Information Communications Technologies, which is derived from Information Technologies, to offer learning.

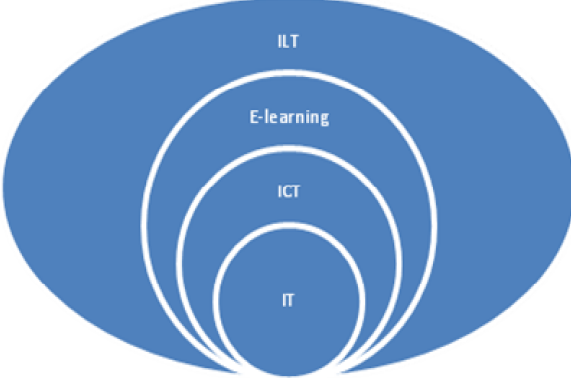
E-learning often refers to technology or designs used in distance teaching, but it also is used to describe any sort of technology use in education. As of 2019, e-learning has been replaced by the word ‘digital learning’ or sometimes EdTech [6]. We prefer continue using ‘educational technology’, although the term ‘digital learning’ is more open to the idea that technology has become a general omnipresent tool, i.e. encompasses any sort of technology use in education.

More design-oriented educational technologists rather look a cross-section of

several phenomena, i.e., they adopt an interdisciplinary approach that will ultimately lead to better pedagogical designs in a given area (Figure 2).

IT	Information Technology	The computer infrastructure, hardware and software used to process data and deliver information.
ICT	Information and communication technologies	The combination of computing and communication technologies (including computer networks and telephone systems) that connect and enable some of today's most exciting systems, e.g. the Internet.
E-learning	Electronic learning	E-learning is learning supported or enhanced through the application of information and communications technology.
ILT*	Information and learning technologies*	This was used in further education colleges, to refer to the use of information and communication technologies to support the core business of colleges: the delivery and management of learning.

\* The current term is e-learning and technology



**Fig. 1.** The Eclipse Diagram by Markos Tiris and the Definitions Used in the Centre of Excellence in Leaderships Report [4]

Educational technology can be considered as a design science and as such, it has developed some specific research methodology like 'Design-based research'. However, since it addresses also all fundamental issues of learning, teaching and social organization, educational technology makes use of the full range of modern social science and life sciences methodology.

### 3 The Future of learning environment

It is known that within the ICPS during the preparation and implementation of training each student has the opportunity to choose the goals, content, method, place and time of training, and in educational organizations – the opportunity to go in different ways in the provision of educational services that meet the requirements of the labor market and social needs. Table 2 shows the comparative characteristics of traditional and e-learning [15].

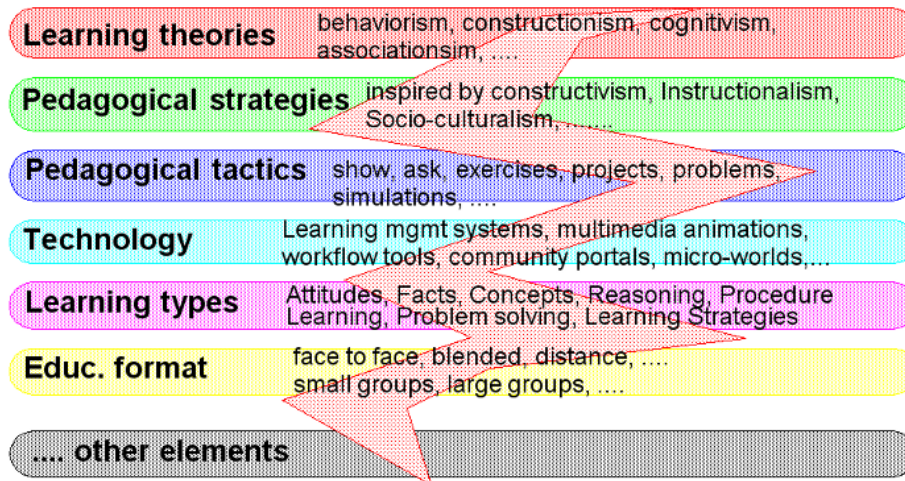


Fig. 2. Interdisciplinary approach for EdTech

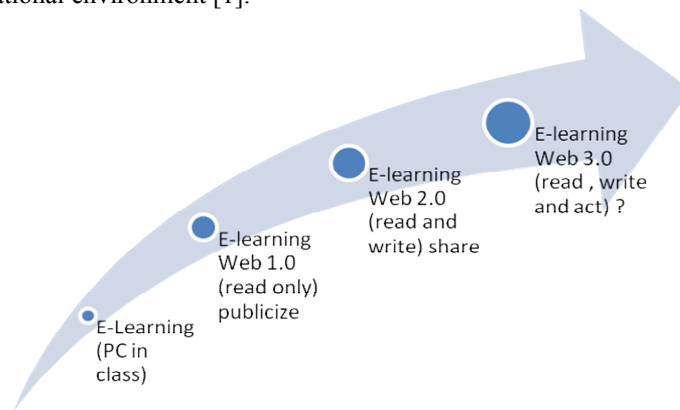
Table 2. Comparative characteristics of traditional and e-learning

Traditional learning	E-learning
Training begins and ends in accordance with established dates.	The student decides when to begin and complete the study program.
The student faces a restriction on the freedom of access to the learning and teaching process.	Student has greater access to programming
The student must attend classes at school or in the workplace	The student decides for himself where to study
The objectives and content of the programs are determined by the institution.	The student, after consulting with the tutors (teacher-consultant), determines the goals and content of training in accordance with his needs and interests.
The sequence of training is determined by the program or teacher - consultant (tutor)	The student, together with the tutors develops a work plan and schedule of classes
The speed of learning is dictated by the program, teacher and group of studies.	The student, together with the tutor, agrees on his own pace.
The teacher provides support mainly through lectures	The tutors and the learner agree on a form of support that can be provided in the form of full-time study or remotely
The student learns by attending lectures and seminars or studying the scientific and methodological literature	Training is carried out with the help of educational materials, which necessarily include: goals, the actual content, methods of self-assessment and other information for independent work

It is expected that the type of technologies for learning and the way they will be used will change the future of education. Nowadays, the common online tool used in blended learning is called Web 1.0. In Web 1.0, information is delivered to users while in Web 2.0 information is created and edited by users. Web 1.0 is a read-only

environment, while Web 2.0 is a read and write environment which facilitates social activities. Blogs, Wikis, Twitter, YouTube, Facebook, and Flickr are examples of the most common Web 2.0 tools. Globally, the number of users of Web 2.0 has increased dramatically [1].

At the same time, e-learning 2.0 promotes collaboration in knowledge construction. The rapid innovations in e-learning urges for research about the impact of these innovations on blended learning. Recently, research has started to explore the effectiveness of using Web 2.0 in blended learning. With the continuous development of the use of web-based applications and 3D virtual worlds like Second Life, which can be called e-learning 3.0 (see Figure 3), there are even more opportunities to create a better engagement blend. The future development of technology will change the delivery modes used, the cost effectiveness and the acceptance and recognition of the new educational environment [1].



**Fig. 3.** The Development of E-learning

Web 1.0 is a linear model ‘site to user’, one-dimensional interaction. The owner of a site is the source of information; the readers are its users. There is no feedback between the site and the users, as if you can write a letter to the editor or call (like the readers of a newspaper).

Web 2.0 is a social web of two-dimensional interaction. The owner of a site manages the information provided by users in accordance with own rules. Users themselves make publications, write comments, and communicate with each other (social networks). Feedback between the site and users is also absent, because users do not formulate rules. Unlike Web 1.0 the owners do not have to fill the site with information as the users do it.

Web 3.0 is a social space, three-dimensional self-organization. The higher level of the Web is a condition where the users of a site are its owners and themselves fill in their information according to their own rules. To manage this information resource they knowingly and voluntarily choose the authorities and, if necessary, update them promptly. The defining features of Web 3.0 are self-financing, self-organization and self-control. Additional features of the third Web are mobility (can be used with Smartphone), scalability (easy expansion) and gamification (elements of gaming



competition). Social 3D networks, formed on the model Web 3.0, acquire features of the collective mind, so they are also called social neural networks, or ecological networks. As the users can communicate with each other, they have an illusion that these conversations have impact on the website.

Moreover, Bonk et al. [3] state that understanding emerging technologies that will influence online learning helps in predicting promising technologies for blended learning. Bonk et al. conducted a survey to explore the perceptions of Higher Education educators of technologies that would most impact the delivery of online education during the next few years. Out of the 14 technologies listed, reusable learning objects, were predicted to have the most significant impact. Some of the other tools were: wireless technologies, collaboration tools, digital libraries and games with simulations.

Furthermore, the predicted expansion of blended learning is likely to be linked to ten trends which are presented in the survey of Bonk et al. [3]. These trends are listed in Table 3. The first trend is the increasing use of mobile and wireless technologies, which foster learning anytime and from anywhere. The second trend indicates that mobile blended learning leads to individualization. Bonk et al. introduce the fourth trend were learners self-regulate their own learning and decide about the design of their own degrees or programs. Global connectedness is also predicted as a feature of blended learning. Looking into the future, Bonk et al. perceive blended learning as a means for building shared cultural understanding on a global basis. For example, with blended learning, courses from various contexts will share similar online Learning Objects such as those provided in the Multimedia Educational Resource for Learning and Online Teaching (MERLOT) website.

Moreover, Bonk et al. [3] predict that blended learning will grow in universities because it reduces class room meeting or seat-time which then decreases the brick and mortar needs but at the same time it can increase learning outcomes. Bonk et al. raise the issue of how course designation in Higher Education might differ according to the percentage of the blend and how courses with one-third credit of online learning might become more respected in the near future than blended courses with only one or two face-to-face meetings.

In addition, Bonk et al. [3] predict the emergence of specialist certificates and even master's degrees for blended learning lecturers. They also state that blended learning lecturers must have the skills that enable them to integrate new activities that meet learners' interests. Certainly, understanding the abilities of the current and future students is the key.

Most of Bonk's predictions were proved by quantitative results of a Mapping Survey conducted in October-December 2013 by the European University Association [7]. 249 answers from higher education institutions, in their majority universities, from 38 European systems (EU and wider Europe), were received. The survey asked about the type of e-learning institutions use, their experiences in this area and their expectations for the future.

The results of the survey show – with very few exceptions – that practically all higher education institutions of the sample have started to embrace e-learning. Most of the surveyed institutions are using blended learning (91%), integrating e-learning

into conventional teaching, but surprisingly 82% of institutions also indicate that they offer online learning courses. Less frequent, but seemingly also on the rise, are other forms of provision such as joint inter-institutional collaboration and online degree courses. Online examinations are likely to become more widely used for all students in all or most disciplines, also for conventionally taught courses. Besides pedagogical and economic motives, the institutions refer to a growing need for flexibility of time and place, and better use of resources, benefiting both residential students and a wider range of professional and other lifelong learners [7, p. 7].

**Table 3.** Trends and Predictions Related to Blended Learning [3]

Mobile Blended Learning	Increasing use of mobile and handheld will create rich and exciting new avenues for blended learning.
Greater Visualization, Individualization, and Hands-on Learning	Blended learning environments will increasingly become individualized; in particular, emphasizing visual and hands-on activities.
Self-Determined Blended Learning	Blended learning will foster greater student responsibility for learning. Decisions about the type and format of blended learning will be made by students instead of instructors or instructional designers. Learners will be designing their own programs and degrees.
Increased Connectedness, Community, and Collaboration	Blended learning will open new avenues for collaboration, community building, and global connectedness. It will become used as a tool for global understanding and appreciation.
Increased Authenticity and On-Demand Learning	Blended learning will focus on authenticity and real world experiences to supplement, extend, enhance, and replace formal learning. As this occurs, blended learning will fuel advancements in the creation and use of online case-learning, scenarios, simulations and role play, and problem-based learning.
Linking Work and Learning	As blended learning proliferates, the lines between workplace learning and formal learning will increasingly blur. Higher education degrees will have credits from the workplace and even credit for work performed.
Changed Calendaring	The calendar system or time scheduling of learning will be less appropriate and pre-definable.
Blended Learning Course Designations	Courses and programs will be increasingly designated as blended learning paths or options.
Changed Instructor Roles	The role of an instructor or trainer in a blended environment will shift to one of mentor, coach, and counsellor.
The Emergence of Blended Learning Specialists	There will emerge specialist teaching certificates, degree programs, and resources or portals related to blended learning courses and programs.

The vast majority of institutions offer blended learning and online learning courses (91% and 82% respectively). While blended learning degree programs (55%), online degree programs (39%) and online learning organized jointly with other institutions (40%) are still less common, 10-14% of respondents said they plan to develop them (Figure 4) [7, p. 26].

The fact that blended learning, the most widespread form of provision, occurs

throughout only one in every four institutions, indicates the very modest level of mainstreaming in e-learning and its huge potential for further development.

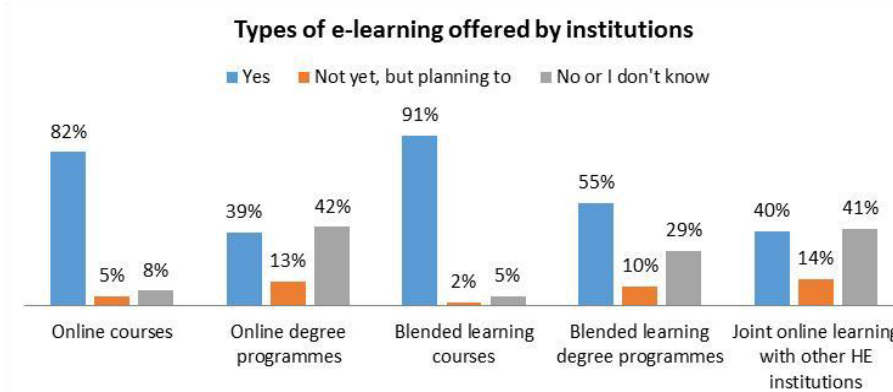


Fig. 4. Does your institution offer any of the following?

The trends that will affect the learning industry, specifically the e-learning landscape, for 2019 are the following:

1. Adaptive Learning Going To The Next Level. Adaptive learning will make further strides in the eLearning marketplace. Organizations and learners will benefit as organizations ensure that there are better competition rates, and learners will enjoy the learning process as they get to see only that content that is personalized to them. Using effective assessments, learners can skip the content that they are completely confident about.
2. Microlearning. It is a great method of implementing learning in small chunks that are objective driven and can be easily and quickly deployed within organizations. Learners benefit as they get through the modules quickly and can repeat the learning many times as well. Microlearning can be implemented as videos, small games, quizzes, and infographics. The great advantage of microlearning is that it can be implemented on any device.
3. Artificial Intelligence and Learner Assistance. Artificial Intelligence will be used to predict learner behaviour, as well as help personalize the learning. Based on the modules that were taken by learners and the difficulties or challenges faced, better personalization will be brought about. Voice-guided bots will also help learners to search for key content in modules. Added to the mix is the use of robots for helping kids and people with special needs to learn new skills, and help them in the moment of need.
4. Gamification and Game-Based Learning. Organizations will look to implement more game-based solutions, as they see them as value adders for the organization-wide learning. Games that are well thought out, well designed and address the needs of learners engage them effectively. It has been proven through numerous implementations that games help in releasing happy hormones, such as dopamine and serotonin.

5. Augmented Reality AR / Virtual Reality VR / Mixed Reality MR. The great thing about Augmented Reality is that it can augment the existing content through interesting overlays of graphics and images that can pop out and thrill the learners. More than the thrill, it is the experience itself that helps learners connect to the content better. Organizations are now looking at Virtual Reality as an important solution, as eLearning companies use effective Instructional Design strategies to enhance the VR experience. Using a mixture of 360-degree photographs, interactions, and many more elements, VR is becoming a useful experience. Organizations are also investing in cognitive learning products that are augmented by VR especially for children and people with special needs. Already big players are making investments in MR which combines AR and VR to a great effect.
6. Video-Based Learning. Videos are one of the hottest modes of training right now. The popularity of video-based sites (like YouTube) has forced organizations to adopt more videos into their training. Be it Instructor-Led Training that is interspersed with anecdotal or contextual videos, or eLearning where videos play an integral part in disseminating information, videos are here to stay.
7. Social Learning. It involves collaboration between individuals at the workplace through various modes, such as forums, informal chat sessions, sharing sessions, and learning circles.
8. Content Curation. It is a method of curating information and providing the learners with just-in-time information. Learning management systems will continue to grow and offer content curation as an important method of sharing information, and provide the right experience to the learners [9].

## 4 Conclusions

The principle difference between today learning environment and the previous one is its ability to react at student's learning activities and needs providing personalized local learning environment. The proliferation of virtual forms for education is a natural stage in education evolution. It covers the whole system from chalkboard to smart board, from a usual library to electronic one, from small training groups to virtual classrooms of any scale, etc. Virtual and traditional forms of education should not be perceived as mutually exclusive. A good education today is a synthesis of various forms acquiring knowledge and modern technologies, the optimal combination of which only the student himself can determine for himself. Hybrid learning environment entered the XXI century as the most promising, synthetic and integral part of education. Historical analysis of the patterns of the most effective approaches in the field of education is extremely important for determining the best ways to improve education today. An essential element of the article is to consider the connection of modern learning environment with the development of information and communication technologies (ICT). It is shown that the future of learning environment will be based on EdTech.

## References

1. Alebaikan, R., Troudi, S.: Blended Learning in Saudi Universities: Challenges and Perspectives. *Research in Learning Technology*. **18**(1), 49–59 (2010). doi:10.1080/09687761003657614
2. Anderson, T., Dron, J.: Three Generations of Distance Education Pedagogy. *International Review of Research in Open and Distance Learning*. **12**(3), 80–97 (2011). doi:10.19173/irrodl.v12i3.890
3. Bonk, C., Kim, K.J., Zeng, T.: Future Directions of Blended Learning in Higher Education and Workplace Settings. In: Bonk, C., Graham, C.R. (Eds.) *Handbook of Blended Learning: Global Perspectives, Local Designs*, pp. 550-567. Pfeiffer, San Francisco (2006)
4. Centre For Excellence – Excelling At Everything. <http://www.centreforexcellence.org.uk> (2017). Accessed 05 Mar 2019
5. Communication from the Commission to the European Parliament, the Council, the European Economic and Social Committee and the Committee of the Regions. <http://eur-lex.europa.eu/legal-content/EN/TXT/PDF/?uri=CELEX:52013DC0654&from=EN> (2013). Accessed 10 Mar 2019
6. Educational technology. [http://edutechwiki.unige.ch/en/Educational\\_technology](http://edutechwiki.unige.ch/en/Educational_technology) (2019). Accessed 15 Mar 2019
7. Gaebel, M., Kupriyanova, V., Morais, R., Colucci, E.: E-Learning in European Higher Education Institutions: Results of a Mapping Survey conducted in October-December 2013. European University Association. <https://eua.eu/resources/publications/368:e-learning-in-european-higher-education-institutions.html> (2014). Accessed 15 Mar 2019
8. Himyak, O.: What is EdTech. 10 most high-profile Ukrainian projects in the field of technology education. <https://techno.nv.ua/technoblogs/chto-takoe-edtech-10-samykh-hromkikh-ukrainskikh-proektov-v-oblasti-tehnolohij-obrazovanija-bloh-ariny-khimjak-2492493.html> (2018) Accessed 15 Mar 2019
9. Kumar DN, S.: 8 Top eLearning Trends For 2019. <https://elearningindustry.com/elearning-trends-for-2019-8-top> (2018). Accessed 15 Mar 2019
10. Lim, C.P., Wang, L.B. (eds.): *Blended Learning for Quality Higher Education: Selected Case Studies on Implementation from Asia-Pacific*. UNESCO, Paris (2016)
11. Littlejohn, A., Pegler, C.: *Preparing for Blended e-Learning*. Routledge, London (2007)
12. Nipper, S.: Third generation distance learning and computer conferencing. In: Mason, R., Kaye, A. (eds.) *Mind weave: Communication, computers and distance education*. Permagon Press, Oxford (1989)
13. Selevko, G.K.: *Modern educational technology*. National Education, Moscow (1998)
14. Spivakovsky, A., Petukhova, L., Spivakovska, E., Kotkova, V., Kravtsov, H.: Three-Subjective Didactic Model. In: Ermolayev, V., Mayr, H.C., Nikitchenko, M., Spivakovsky, A., Zholtkevych, G. (eds.) *Information and Communication Technologies in Education, Research, and Industrial Applications. ICTERI 2013. Communications in Computer and Information Science*, vol. 412, pp. 252–273. Springer, Cham (2013). doi:10.1007/978-3-319-03998-5\_13
15. Spivakovsky, A.V. (ed.): *New didactics: from subject-subject to threesubject relations*. Aylant, Kherson (2016)
16. Home – NCTE. <http://www2.ncte.org> (2018). Accessed 10 Mar 2019
17. Vedrenne-Cloquet, B.: What is EdTech and why is it such a big opportunity? <https://www.hottopics.ht/14731/what-is-edtech-and-why-is-it-important> (2018). Accessed 10 Mar 2019

## Author Index

<b>A</b>	
Abisheva, Akmaral	729
Akhmedova, Olena	450
Aleksander, Marek	716
Andrashov, Anton	738
Antoniuk, Viktor	749
Atamaniuk, Valeriia	302
Atamanyuk, Igor	302
<b>B</b>	
Babenko, Vitalina	595
Baglai, Roman	316
Balyk, Nadiia	68, 204, 960
Banschykov, Petr	935
Baryshevska, Inna	302
Bashyns'ka, Ol'ha	822
Bauyrzhan, Madina	716
Bielinskyi, Andrii	434
Bilashenko, Svitlana	984
Bilinets, Marina	473
Bilousova, Lyudmyla	880
Bobrovnikova, Kira	617
Boyarchuk, Artem	617, 738
Brovko, Dmytro	952
Buchatska, Iryna	919
Burlaka, Oleksandr	704
Burov, Oleksandr	170
Buyak, Bogdan	29
<b>C</b>	
Chemerys, Hanna	17
Chernenko, Irina	41
Chernova, Maryna	968
<b>D</b>	
Danova, Mariia	655
Davidenko, Kateryna	121
Demirbilek, Muhammet	944
Derykolenko, Oleksandr	269
Dotsenko, Iryna	984
Drozd, Miroslav	749
Drozd, Oleksandr	749
Dubovyk, Tetiana	919
Dychka, Ivan	534
<b>F</b>	

Fedosov, Viktor	393
Feoktystova, Olena	655
Flehanov, Leonid	864
<b>G</b>	
Gamova, Iryna	919
Gardner, Greg	220
Gnatyuk, Sergiy	810
Gnatyuk, Viktor	716
Gnedkova, Olga	121
Goncharenko, Tatiana	132
<b>H</b>	
Hladchenko, Lidiia	473
Horbachov, Peter	678
Hovorushchenko, Tetiana	617
Hruntova, Tetiana	952
Hryshchenko, Oleksandr	935
Hu, Zhengbing	810
Hurman, Ivan	633
<b>I</b>	
Iavich, Maksim	810
Ibraimov, Margulan	729
Ivanov, Ievgen	542
<b>K</b>	
Kalimoldayev, Maksat	729
Kazymyr, Volodymyr	822
Kharchenko, Vyacheslav	664, 738, 794
Kharlai, Liudmila	716
Kharlamova, Ganna	316
Khokhlov, Serik	729
Kilinich, Daria	277
Kinzeryavyy, Vasyl	810
Kiv, Arnold	833
Kobets, Vitaliy	277, 406
Kobylin, Oleg	53
Koc, Durmus	944
Kohut, Uliana	81, 93
Kokareva, Anzhelika	716
Kolgatin, Oleksandr	880
Kolgatina, Larisa	880
Konchunas, Julian	694
Kondratenko, Yuriy	302
Kosyk, Victoria	935
Kotkova, Vera	191
Kotkova, Vira	1011
Kozibroda, Serhiy	29

Kozlovsky, Evgen	41
Kravets, Tetyana	348
Kravtsov, Hennadiy	1, 121
Kravtsova, Lyudmyla	849
Kruhlyk, Vladyslav	17
Krylova-Grek, Yuliya	229
Kubatko, Oleksandr	269
Kudriavets, Yevhen	379
Kukhareno, Vladimir	156
Kunanets, Nataliia	241
Kushnir, Nataliya	132, 144
Kuzmenkov, Sergiy	1
Kuzminska, Olena	53
<b>L</b>	
Lavrov, Evgeniy	1000
Lavrova, Olga	1000
Le, Chan	364
Leonchuk, Yevhen	465
Letychevskiy, Oleksandr	577, 694
Liashenko, Olena	348
Lishchuk, Tetiana	121
Lola, Yuliia	450
Lvov, Michael	1, 41, 497
Lysak, Viktor	257
Lysenko, Sergii	633
Lysenko, Yaroslav	332
Lytvynova, Svitlana	68, 105, 170
<b>M</b>	
Magzom, Miras	729
Makarichev, Oleksandr	678
Markova, Oksana	833
Maschak, Andriy	778
Matsenko, Oleksandr	269
Matviychuk, Andriy	485
Mazorchuk, Mariia	53
Mazurok, Igor	465
Meier, Jan-Hendrik	364
Melnyk, Leonid	269
Melnyk, Olga	655
Mikhno, Inesa	289
Moiseenko, Natalia	905
Morze, Nataliia	53
<b>N</b>	
Nechypurenko, Pavlo	968
Nesterenko, Sergii	822



Nicheporuk, Andrii	633
Nikitchenko, Mykola	542, 603
Nosenko, Yuliya	178
Nyzhnyk, Irina	257
<b>O</b>	
Odrekhivskyy, Mykola	241
Oleinik, Tatyana	156
Oleksiuk, Vasyl	68, 204, 960
Omelchuk, Liudmyla	522
Orlovsky, Maxim	694
Osadcha, Kateryna	17
Osadchyi, Viacheslav	17, 144
Osipova, Nataliia	121, 132
Ovsienko, Yuliia	864
Ozirkovskyy, Leonid	778
<b>P</b>	
Paientko, Tetiana	332, 393, 473
Panchenko, Liubov	895
Pankratova, Liubov	289, 332
Panova, Kateryna	220
Pasichnyk, Volodymyr	241
Pavlova, Olga	617
Pazdrii, Vitalii	935
Perminova, Liudmula	191
Peschanenko, Vladimir	585, 694
Peschanenko, Volodymyr	577
Petliuk, Ivan	762
Petukhova, Lyubov	1011
Pienko, Valeriy	465
Poltoratskyi, Maksym	577
Poltorackiy, Maksym	220, 585
Poltorak, Anastasiya	302
Ponochovnyi, Yuriy	738
Popel, Maiia	93
Popova, Olga	289
Prokopovych, Svitlana	450
Pryimak, Karina	585
Puliaieva, Anna	849
Pursky, Oleg	919
<b>R</b>	
Radchenko, Viktor	577, 694
Rahimi, Yashar	655
Repskyi, Victor	29
Roskladka, Andrii	316
Roskladka, Nataliia	316

Rybalchenko, Olena	984
Rzheuskyi, Antonii	241
<b>S</b>	
Sachtachtinskagia, Sabina	694
Saitgareev, Levan	984
Savenko, Oleg	633
Schneider, Stephan	364
Selivanova, Tetiana	968
Selyutin, Victor	422
Semerikov, Serhiy	833
Shapovalova, Nonna	984
Shebanin, Vyacheslav	302
Shishko, Ludmila	41
Shkiliuk, Oleksandr	762
Shkilniak, Oksana	603
Shkilniak, Stepan	603
Shmelova, Tetiana	704
Shmyger, Galina	204, 960
Shostak, Igor	655
Shyshatska, Olena	522
Shyshkina, Mariya	81, 93
Sirenko, Natalia	302
Skaskiv, Anna	204
Sklyar, Vladimir	664
Skobelev, Volodymyr G.	513, 644, 694
Skobelev, Volodymyr V.	644
Slobodyanyk, Olga	170
Smirnov, Serhii	716
Sobol, Andrey	694
Soloviev, Vladimir	434, 833, 905
Solovieva, Viktoria	434
Spirin, Oleg	68
Spivakovska, Yevheniia	191, 220
Spivakovsky, Aleksander	220, 1011
Stepova, Hanna	749
Stereharz, Arnold	704
Strelchenko, Inna	485
Strielkina, Anastasiia	794
Striuk, Andrii	984
Sukhikh, Alisa	178
Sulema, Olga	534
Svichynskyi, Stanislav	678
Sydorenko, Sergiy	68
Sydorenko, Viktoriia	729
<b>T</b>	

Tabachyshyn, Danylo	241
Tarasich, Yulia	220
Tarasich, Yuliia	577
Tarasova, Olena	905
Teplytskyi, Illia	833
Tkachuk, Viktoriia	952
Tron, Vitaliy	952
Tropina, Irina	935
Tsidylo, Ivan	29
Tynymbayev, Sahibay	729
<b>V</b>	
Valko, Nataliia	132, 144
Vashchaiev, Serhii	485
Vasylenko, Yaroslav	204, 960
Velykoivanenko, Halyna	485
Vinnik, Maxim	220
Vinnyk, Tetyana	191
Volochiy, Bohdan	762, 778
Volochiy, Serhiy	794
Voronkov, Oleksandr	678
Voynarenko, Mykhaylo	406
<b>W</b>	
Weissblut, Alexander	552
<b>Y</b>	
Yatsenko, Valeria	406
Yatsenko, Viktoria	379
Yechkalo, Yuliia	833, 952
Yubuzova, Khalicha	810
Yurchuk, Yuriy	1011
<b>Z</b>	
Zaytseva, Tatyana	849
Zhmurko, Tetyana	810
Zholtkevych, Grygoriy	568
Zmysnyi, Mykhailo	778